



Chipsmall Limited consists of a professional team with an average of over 10 year of expertise in the distribution of electronic components. Based in Hongkong, we have already established firm and mutual-benefit business relationships with customers from,Europe,America and south Asia,supplying obsolete and hard-to-find components to meet their specific needs.

With the principle of "Quality Parts,Customers Priority,Honest Operation,and Considerate Service",our business mainly focus on the distribution of electronic components. Line cards we deal with include Microchip,ALPS,ROHM,Xilinx,Pulse,ON,Everlight and Freescale. Main products comprise IC,Modules,Potentiometer,IC Socket,Relay,Connector.Our parts cover such applications as commercial,industrial, and automotives areas.

We are looking forward to setting up business relationship with you and hope to provide you with the best service and solution. Let us make a better world for our industry!



Contact us

Tel: +86-755-8981 8866 Fax: +86-755-8427 6832

Email & Skype: info@chipsmall.com Web: www.chipsmall.com

Address: A1208, Overseas Decoration Building, #122 Zhenhua RD., Futian, Shenzhen, China



FEATURES

- Two-Channel Simultaneously Sampling ADC
- 77dB SNR
- 90dB SFDR
- Low Power: 160mW/115mW/78mW Total
80mW/58mW/39mW per Channel
- Single 1.8V Supply
- CMOS, DDR CMOS, or DDR LVDS Outputs
- Selectable Input Ranges: 1V_{P-P} to 2V_{P-P}
- 550MHz Full Power Bandwidth S/H
- Optional Data Output Randomizer
- Optional Clock Duty Cycle Stabilizer
- Shutdown and Nap Modes
- Serial SPI Port for Configuration
- 64-Pin (9mm × 9mm) QFN Package

APPLICATIONS

- Communications
- Cellular Base Stations
- Software Defined Radios
- Portable Medical Imaging
- Multi-Channel Data Acquisition
- Nondestructive Testing

DESCRIPTION

The LTC[®]2182/LTC2181/LTC2180 are two-channel simultaneous sampling 16-bit A/D converters designed for digitizing high frequency, wide dynamic range signals. They are perfect for demanding communications applications with AC performance that includes 77dB SNR and 90dB spurious free dynamic range (SFDR). Ultralow jitter of 0.07ps_{RMS} allows undersampling of IF frequencies with excellent noise performance.

DC specs include ±2LSB INL (typ), ±0.5LSB DNL (typ) and no missing codes over temperature. The transition noise is 3.3LSB_{RMS}.

The digital outputs can be either full rate CMOS, Double Data Rate CMOS, or Double Data Rate LVDS. A separate output power supply allows the CMOS output swing to range from 1.2V to 1.8V.

The ENC⁺ and ENC⁻ inputs may be driven differentially or single-ended with a sine wave, PECL, LVDS, TTL, or CMOS inputs. An optional clock duty cycle stabilizer allows high performance at full speed for a wide range of clock duty cycles.

LT, LT, LTC, LTM, Linear Technology and the Linear logo are registered trademarks of Linear Technology Corporation. All other trademarks are the property of their respective owners.

TYPICAL APPLICATION

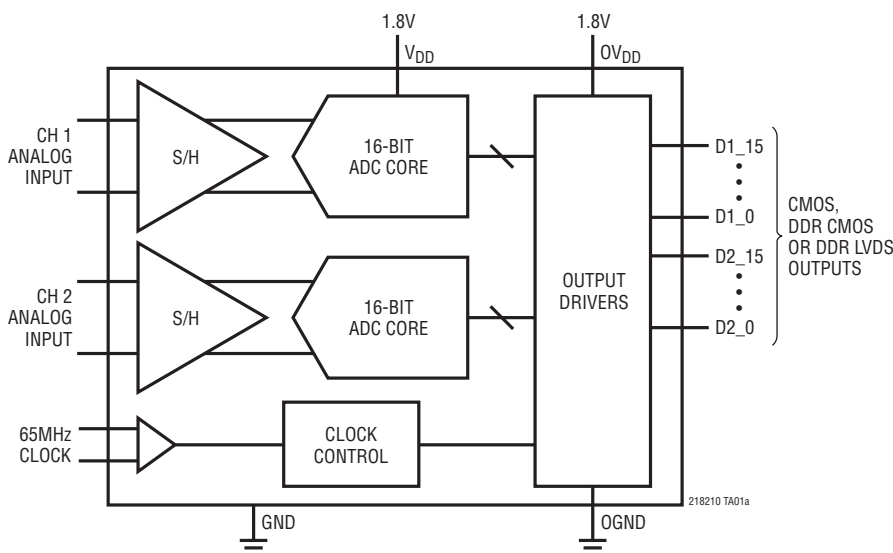

2-Tone FFT, $f_{IN} = 70\text{MHz}$ and 69MHz

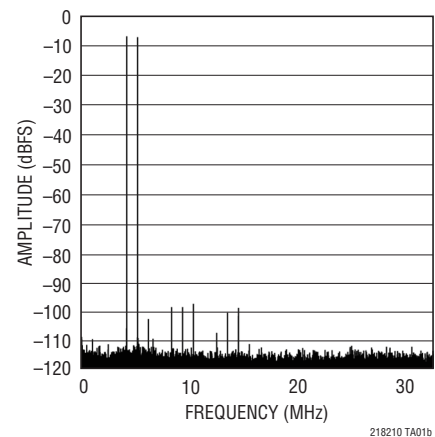

LTC2182/LTC2181/LTC2180

ABSOLUTE MAXIMUM RATINGS (Notes 1, 2)

Supply Voltages (V_{DD} , $0V_{DD}$) -0.3V to 2V
 Analog Input Voltage (A_{IN}^+ , A_{IN}^- ,
 PAR/SER, SENSE) (Note 3) -0.3V to ($V_{DD} + 0.2V$)
 Digital Input Voltage (ENC^+ , ENC^- , \overline{CS} ,
 SDI, SCK) (Note 4) -0.3V to 3.9V
 SDO (Note 4) -0.3V to 3.9V

Digital Output Voltage -0.3V to ($0V_{DD} + 0.3V$)
 Operating Temperature Range
 LTC2182C, LTC2181C, LTC2180C 0°C to 70°C
 LTC2182I, LTC2181I, LTC2180I -40°C to 85°C
 Storage Temperature Range -65°C to 150°C

PIN CONFIGURATIONS

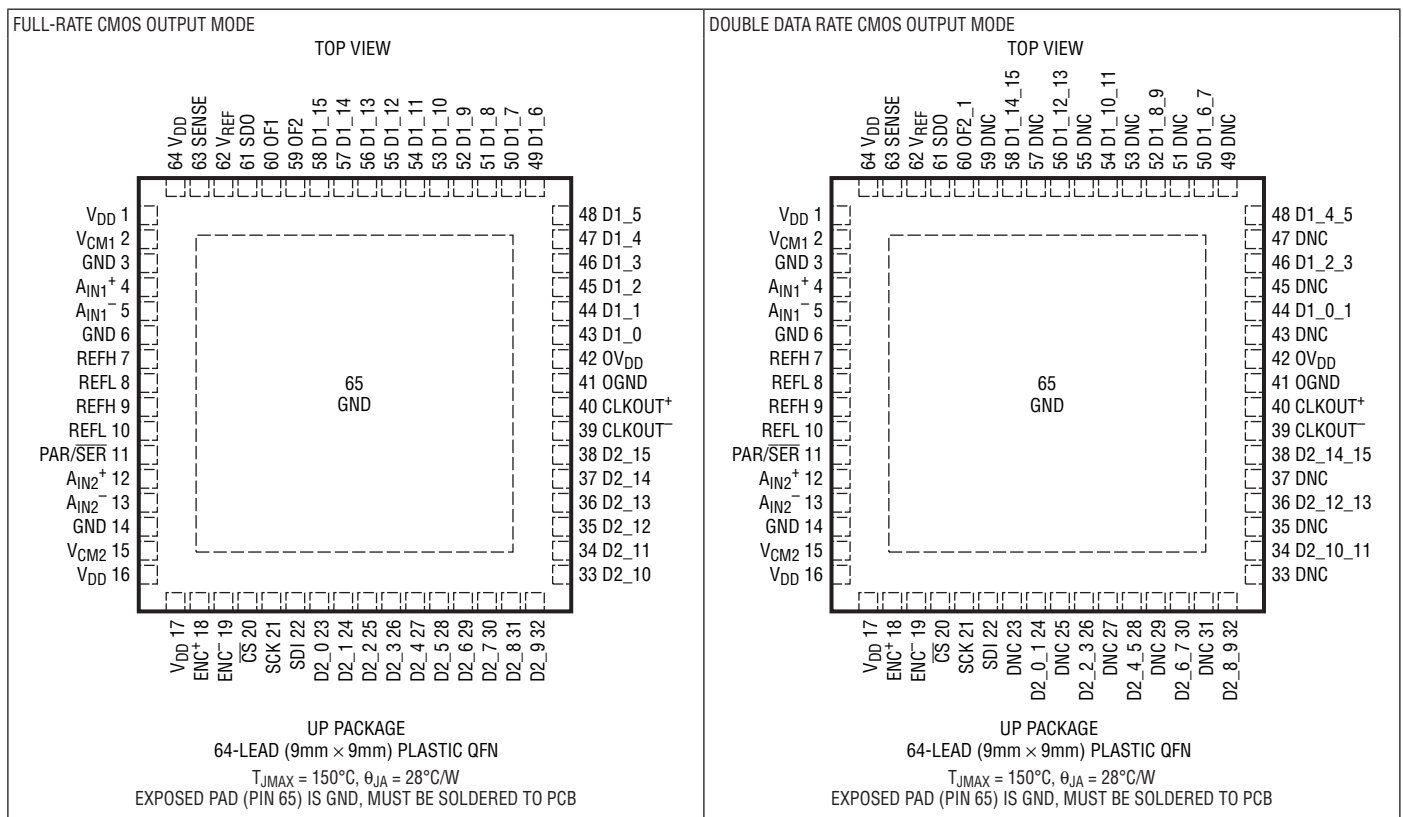

PIN CONFIGURATIONS

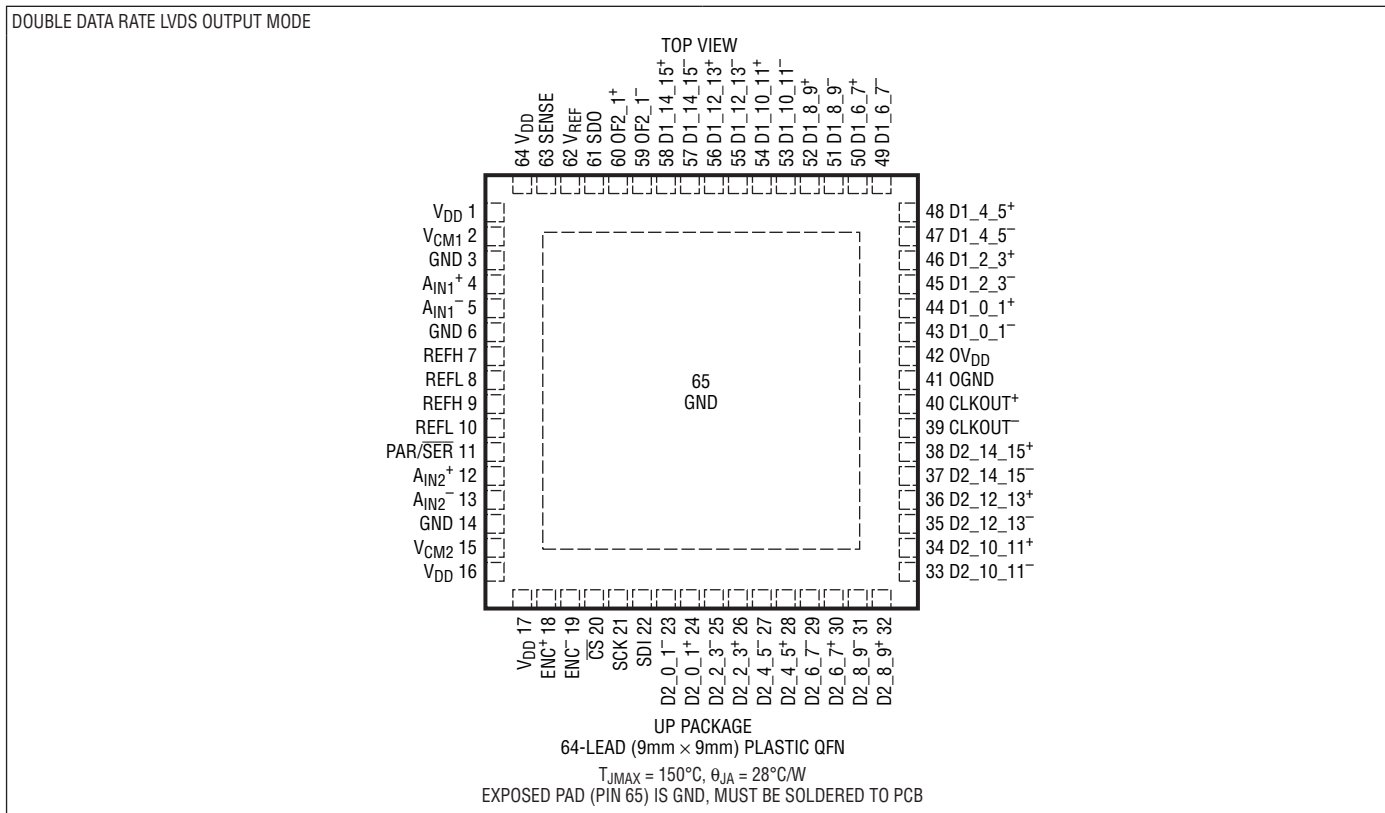

ORDER INFORMATION

| LEAD FREE FINISH | TAPE AND REEL | PART MARKING* | PACKAGE DESCRIPTION | TEMPERATURE RANGE |
|------------------|------------------|---------------|---------------------------------|-------------------|
| LTC2182CUP#PBF | LTC2182CUP#TRPBF | LTC2182UP | 64-Lead (9mm × 9mm) Plastic QFN | 0°C to 70°C |
| LTC2182IUP#PBF | LTC2182IUP#TRPBF | LTC2182UP | 64-Lead (9mm × 9mm) Plastic QFN | -40°C to 85°C |
| LTC2181CUP#PBF | LTC2181CUP#TRPBF | LTC2181UP | 64-Lead (9mm × 9mm) Plastic QFN | 0°C to 70°C |
| LTC2181IUP#PBF | LTC2181IUP#TRPBF | LTC2181UP | 64-Lead (9mm × 9mm) Plastic QFN | -40°C to 85°C |
| LTC2180CUP#PBF | LTC2180CUP#TRPBF | LTC2180UP | 64-Lead (9mm × 9mm) Plastic QFN | 0°C to 70°C |
| LTC2180IUP#PBF | LTC2180IUP#TRPBF | LTC2180UP | 64-Lead (9mm × 9mm) Plastic QFN | -40°C to 85°C |

Consult LTC Marketing for parts specified with wider operating temperature ranges. *The temperature grade is identified by a label on the shipping container. Consult LTC Marketing for information on non-standard lead based finish parts.

For more information on lead free part marking, go to: <http://www.linear.com/leadfree/>

For more information on tape and reel specifications, go to: <http://www.linear.com/tapeandreel/>

LTC2182/LTC2181/LTC2180

CONVERTER CHARACTERISTICS

The ● denotes the specifications which apply over the full operating temperature range, otherwise specifications are at $T_A = 25^\circ\text{C}$. (Note 5)

| PARAMETER | CONDITIONS | LTC2182 | | | LTC2181 | | | LTC2180 | | | UNITS | |
|-------------------------------|--|---------|------|--------------|---------|------|--------------|---------|------|--------------|-------|--|
| | | MIN | TYP | MAX | MIN | TYP | MAX | MIN | TYP | MAX | | |
| Resolution (No Missing Codes) | | ● | 16 | | | 16 | | | 16 | | Bits | |
| Integral Linearity Error | Differential Analog Input (Note 6) | ● | -6 | ±2 | 6 | -6 | ±2 | 6 | -6 | ±2 | 6 | LSB |
| Differential Linearity Error | Differential Analog Input | ● | -0.9 | ±0.5 | 0.9 | -0.9 | ±0.5 | 0.9 | -0.9 | ±0.5 | 0.9 | LSB |
| Offset Error | (Note 7) | ● | -7 | ±1.5 | 7 | -7 | ±1.5 | 7 | -7 | ±1.5 | 7 | mV |
| Gain Error | Internal Reference External Reference | ● | -1.8 | ±1.5 -0.5 | 0.8 | -1.8 | ±1.5 -0.5 | 0.8 | -1.8 | ±1.5 -0.5 | 0.8 | %FS %FS |
| Offset Drift | | | | ±10 | | | ±10 | | | ±10 | | $\mu\text{V}/^\circ\text{C}$ |
| Full-Scale Drift | Internal Reference External Reference | | | ±30 ±10 | | | ±30 ±10 | | | ±30 ±10 | | ppm/ $^\circ\text{C}$ ppm/ $^\circ\text{C}$ |
| Gain Matching | | | | ±0.3 | | | ±0.3 | | | ±0.3 | | %FS |
| Offset Matching | | | | ±1.5 | | | ±1.5 | | | ±1.5 | | mV |
| Transition Noise | | | | 3.3 | | | 3.3 | | | 3.2 | | LSB_{RMS} |

ANALOG INPUT

The ● denotes the specifications which apply over the full operating temperature range, otherwise specifications are at $T_A = 25^\circ\text{C}$. (Note 5)

| SYMBOL | PARAMETER | CONDITIONS | MIN | TYP | MAX | UNITS | |
|---------------------|--|--|-----|-------|-----------------|---|---------------|
| V_{IN} | Analog Input Range ($A_{\text{IN}}^+ - A_{\text{IN}}^-$) | $1.7\text{V} < V_{\text{DD}} < 1.9\text{V}$ | | ● | 1 to 2 | $V_{\text{P-P}}$ | |
| $V_{\text{IN(CM)}}$ | Analog Input Common Mode ($(A_{\text{IN}}^+ + A_{\text{IN}}^-)/2$) | Differential Analog Input (Note 8) | ● | 0.7 | V_{CM} | 1.25 | V |
| V_{SENSE} | External Voltage Reference Applied to SENSE | External Reference Mode | ● | 0.625 | 1.250 | 1.300 | V |
| I_{INCM} | Analog Input Common Mode Current | Per Pin, 65Msps Per Pin, 40Msps Per Pin, 25Msps | | | 104 64 40 | μA μA μA | |
| I_{IN1} | Analog Input Leakage Current (No Encode) | $0 < A_{\text{IN}}^+, A_{\text{IN}}^- < V_{\text{DD}}$ | ● | -1 | | 1 | μA |
| I_{IN2} | PAR/SER Input Leakage Current | $0 < \text{PAR/SER} < V_{\text{DD}}$ | ● | -3 | | 3 | μA |
| I_{IN3} | SENSE Input Leakage Current | $0.625 < \text{SENSE} < 1.3\text{V}$ | ● | -6 | | 6 | μA |
| t_{AP} | Sample-and-Hold Acquisition Delay Time | | | | 0 | ns | |
| t_{JITTER} | Sample-and-Hold Acquisition Delay Jitter | Single-Ended Encode Differential Encode | | | 0.07 0.09 | pSRMS pSRMS | |
| CMRR | Analog Input Common Mode Rejection Ratio | | | | 80 | dB | |
| BW-3B | Full-Power Bandwidth | Figure 6 Test Circuit | | | 550 | MHz | |

DYNAMIC ACCURACY The ● denotes the specifications which apply over the full operating temperature range, otherwise specifications are at $T_A = 25^\circ\text{C}$. $A_{IN} = -1\text{dBFS}$. (Note 5)

| SYMBOL | PARAMETER | CONDITIONS | LTC2182 | | | LTC2181 | | | LTC2180 | | | UNITS |
|-------------|---|--------------|---------|------|------|---------|------|------|---------|------|------|-------|
| | | | MIN | TYP | MAX | MIN | TYP | MAX | MIN | TYP | MAX | |
| SNR | Signal-to-Noise Ratio | 5MHz Input | ● | | 77 | | 76.9 | | 77.1 | | dBFS | |
| | | 30MHz Input | | 75.6 | 76.9 | 75.4 | 76.8 | 75.5 | 77 | dBFS | | |
| | | 70MHz Input | | | 76.8 | | 76.7 | | 76.9 | dBFS | | |
| | | 140MHz Input | | | 76.3 | | 76.2 | | 76.4 | dBFS | | |
| SFDR | Spurious Free Dynamic Range 2nd Harmonic | 5MHz Input | ● | | 90 | | 90 | | 90 | | dBFS | |
| | | 30MHz Input | | 82 | 90 | 84 | 90 | 85 | 90 | dBFS | | |
| | | 70MHz Input | | | 89 | | 89 | | 89 | dBFS | | |
| | | 140MHz Input | | | 84 | | 84 | | 84 | dBFS | | |
| | Spurious Free Dynamic Range 3rd Harmonic | 5MHz Input | ● | | 90 | | 90 | | 90 | | dBFS | |
| | | 30MHz Input | | 83 | 90 | 84 | 90 | 85 | 90 | dBFS | | |
| | | 70MHz Input | | | 89 | | 89 | | 89 | dBFS | | |
| | Spurious Free Dynamic Range 4th Harmonic or Higher | 5MHz Input | ● | | 95 | | 95 | | 95 | | dBFS | |
| | | 30MHz Input | | 89 | 95 | 89 | 95 | 89 | 95 | dBFS | | |
| 70MHz Input | | | | 95 | | 95 | | 95 | dBFS | | | |
| S/(N+D) | Signal-to-Noise Plus Distortion Ratio | 5MHz Input | ● | | 76.8 | | 76.7 | | 76.9 | | dBFS | |
| | | 30MHz Input | | 74.9 | 76.7 | 74.9 | 76.6 | 74.9 | 76.8 | dBFS | | |
| | | 70MHz Input | | | 76.4 | | 76.3 | | 76.5 | dBFS | | |
| | | 140MHz Input | | | 76.3 | | 75.2 | | 76.4 | dBFS | | |
| | Crosstalk | 10MHz Input | | -110 | | -110 | | -110 | | dBc | | |

INTERNAL REFERENCE CHARACTERISTICS The ● denotes the specifications which apply over the full operating temperature range, otherwise specifications are at $T_A = 25^\circ\text{C}$. (Note 5)

| PARAMETER | CONDITIONS | MIN | TYP | MAX | UNITS |
|------------------------------------|--|----------------------------------|--------------------|----------------------------------|-----------------------|
| V_{CM} Output Voltage | $I_{OUT} = 0$ | $0.5 \cdot V_{DD} - 25\text{mV}$ | $0.5 \cdot V_{DD}$ | $0.5 \cdot V_{DD} + 25\text{mV}$ | V |
| V_{CM} Output Temperature Drift | | | ± 25 | | ppm/ $^\circ\text{C}$ |
| V_{CM} Output Resistance | $-600\mu\text{A} < I_{OUT} < 1\text{mA}$ | | 4 | | Ω |
| V_{REF} Output Voltage | $I_{OUT} = 0$ | 1.225 | 1.250 | 1.275 | V |
| V_{REF} Output Temperature Drift | | | ± 25 | | ppm/ $^\circ\text{C}$ |
| V_{REF} Output Resistance | $-400\mu\text{A} < I_{OUT} < 1\text{mA}$ | | 7 | | Ω |
| V_{REF} Line Regulation | $1.7\text{V} < V_{DD} < 1.9\text{V}$ | | 0.6 | | mV/V |

LTC2182/LTC2181/LTC2180

DIGITAL INPUTS AND OUTPUTS

The ● denotes the specifications which apply over the full operating temperature range, otherwise specifications are at $T_A = 25^\circ\text{C}$. (Note 5)

| SYMBOL | PARAMETER | CONDITIONS | MIN | TYP | MAX | UNITS |
|---|------------------------------------|---|-----|-------|----------------|-----------------|
| ENCODE INPUTS (ENC⁺, ENC⁻) | | | | | | |
| Differential Encode Mode (ENC⁻ Not Tied to GND) | | | | | | |
| V _{ID} | Differential Input Voltage | (Note 8) | ● | 0.2 | | V |
| V _{ICM} | Common Mode Input Voltage | Internally Set Externally Set (Note 8) | ● | 1.1 | 1.2 1.6 | V V |
| V _{IN} | Input Voltage Range | ENC ⁺ , ENC ⁻ to GND | ● | 0.2 | 3.6 | V |
| R _{IN} | Input Resistance | (See Figure 10) | | 10 | | kΩ |
| C _{IN} | Input Capacitance | (Note 8) | | 3.5 | | pF |
| Single-Ended Encode Mode (ENC⁻ Tied to GND) | | | | | | |
| V _{IH} | High Level Input Voltage | V _{DD} = 1.8V | ● | 1.2 | | V |
| V _{IL} | Low Level Input Voltage | V _{DD} = 1.8V | ● | | 0.6 | V |
| V _{IN} | Input Voltage Range | ENC ⁺ to GND | ● | 0 | 3.6 | V |
| R _{IN} | Input Resistance | (See Figure 11) | | 30 | | kΩ |
| C _{IN} | Input Capacitance | (Note 8) | | 3.5 | | pF |
| DIGITAL INPUTS (CS, SDI, SCK in Serial or Parallel Programming Mode. SDO in Parallel Programming Mode) | | | | | | |
| V _{IH} | High Level Input Voltage | V _{DD} = 1.8V | ● | 1.3 | | V |
| V _{IL} | Low Level Input Voltage | V _{DD} = 1.8V | ● | | 0.6 | V |
| I _{IN} | Input Current | V _{IN} = 0V to 3.6V | ● | -10 | 10 | μA |
| C _{IN} | Input Capacitance | (Note 8) | | 3 | | pF |
| SDO OUTPUT (Serial Programming Mode. Open-Drain Output. Requires 2kΩ Pull-Up Resistor if SDO is Used) | | | | | | |
| R _{OL} | Logic Low Output Resistance to GND | V _{DD} = 1.8V, SDO = 0V | | 200 | | Ω |
| I _{OH} | Logic High Output Leakage Current | SDO = 0V to 3.6V | ● | -10 | 10 | μA |
| C _{OUT} | Output Capacitance | (Note 8) | | 3 | | pF |
| DIGITAL DATA OUTPUTS (CMOS MODES: FULL DATA RATE AND DOUBLE DATA RATE) | | | | | | |
| 0V_{DD} = 1.8V | | | | | | |
| V _{OH} | High Level Output Voltage | I _O = -500μA | ● | 1.750 | 1.790 | V |
| V _{OL} | Low Level Output Voltage | I _O = 500μA | ● | 0.010 | 0.050 | V |
| 0V_{DD} = 1.5V | | | | | | |
| V _{OH} | High Level Output Voltage | I _O = -500μA | | 1.488 | | V |
| V _{OL} | Low Level Output Voltage | I _O = 500μA | | 0.010 | | V |
| 0V_{DD} = 1.2V | | | | | | |
| V _{OH} | High Level Output Voltage | I _O = -500μA | | 1.185 | | V |
| V _{OL} | Low Level Output Voltage | I _O = 500μA | | 0.010 | | V |
| DIGITAL DATA OUTPUTS (LVDS MODE) | | | | | | |
| V _{OD} | Differential Output Voltage | 100Ω Differential Load, 3.5mA Mode 100Ω Differential Load, 1.75mA Mode | ● | 247 | 350 175 | 454 mV mV |
| V _{OS} | Common Mode Output Voltage | 100Ω Differential Load, 3.5mA Mode 100Ω Differential Load, 1.75mA Mode | ● | 1.125 | 1.250 1.250 | V V |
| R _{TERM} | On-Chip Termination Resistance | Termination Enabled, 0V _{DD} = 1.8V | | 100 | | Ω |

POWER REQUIREMENTS The ● denotes the specifications which apply over the full operating temperature range, otherwise specifications are at T_A = 25°C. (Note 9)

| SYMBOL | PARAMETER | CONDITIONS | LTC2182 | | | LTC2181 | | | LTC2180 | | | UNITS | |
|---|------------------------|--|---------|-----|------------|---------|-----|------------|---------|-----|--------------|-------|----------|
| | | | MIN | TYP | MAX | MIN | TYP | MAX | MIN | TYP | MAX | | |
| CMOS Output Modes: Full Data Rate and Double Data Rate | | | | | | | | | | | | | |
| V _{DD} | Analog Supply Voltage | (Note 10) | ● | 1.7 | 1.8 | 1.9 | 1.7 | 1.8 | 1.9 | 1.7 | 1.8 | 1.9 | V |
| OV _{DD} | Output Supply Voltage | (Note 10) | ● | 1.1 | 1.8 | 1.9 | 1.1 | 1.8 | 1.9 | 1.1 | 1.8 | 1.9 | V |
| I _{VDD} | Analog Supply Current | DC Input Sine Wave Input | ● | | 89 91 | 99 | | 64 66 | 72 | | 43.5 44.5 | 50 | mA mA |
| I _{OVDD} | Digital Supply Current | Sine Wave Input, OV _{DD} = 1.2V | | | 5 | | | 3 | | | 2 | | mA |
| P _{DISS} | Power Dissipation | DC Input Sine Wave Input, OV _{DD} = 1.2V | ● | | 160 170 | 179 | | 115 122 | 130 | | 78.3 82.5 | 90 | mW mW |

LVDS Output Mode

| | | | | | | | | | | | | | |
|-------------------|--|---|---|-----|------------|-----|-----|------------|-----|-----|--------------|-----|----------|
| V _{DD} | Analog Supply Voltage | (Note 10) | ● | 1.7 | 1.8 | 1.9 | 1.7 | 1.8 | 1.9 | 1.7 | 1.8 | 1.9 | V |
| OV _{DD} | Output Supply Voltage | (Note 10) | ● | 1.7 | 1.8 | 1.9 | 1.7 | 1.8 | 1.9 | 1.7 | 1.8 | 1.9 | V |
| I _{VDD} | Analog Supply Current | Sine Input, 1.75mA Mode Sine Input, 3.5mA Mode | ● | | 93 95 | 106 | | 68 70 | 77 | | 46.5 48.5 | 54 | mA mA |
| I _{OVDD} | Digital Supply Current (OV _{DD} = 1.8V) | Sine Input, 1.75mA Mode Sine Input, 3.5mA Mode | ● | | 39 74 | 83 | | 38 74 | 83 | | 38 74 | 83 | mA mA |
| P _{DISS} | Power Dissipation | Sine Input, 1.75mA Mode Sine Input, 3.5mA Mode | ● | | 237 304 | 341 | | 191 259 | 288 | | 152 221 | 247 | mW mW |

All Output Modes

| | | | | | | | | | | | | | |
|----------------------|---|--|--|--|----|--|--|----|--|--|----|--|----|
| P _{SLEEP} | Sleep Mode Power | | | | 1 | | | 1 | | | 1 | | mW |
| P _{NAP} | Nap Mode Power | | | | 10 | | | 10 | | | 10 | | mW |
| P _{DIFFCLK} | Power Increase with Differential Encode Mode Enabled (No increase for Nap or Sleep Modes) | | | | 20 | | | 20 | | | 20 | | mW |

TIMING CHARACTERISTICS The ● denotes the specifications which apply over the full operating temperature range, otherwise specifications are at T_A = 25°C. (Note 5)

| SYMBOL | PARAMETER | CONDITIONS | LTC2182 | | | LTC2181 | | | LTC2180 | | | UNITS | |
|-----------------|--|---------------------------|---------|-----|------|---------|-------|------|---------|-----|-----|-------|-----|
| | | | MIN | TYP | MAX | MIN | TYP | MAX | MIN | TYP | MAX | | |
| f _S | Sampling Frequency | (Note 10) | ● | 1 | | 65 | 1 | | 40 | 1 | | 25 | MHz |
| t _L | ENC Low Time (Note 8) | Duty Cycle Stabilizer Off | ● | 7.3 | 7.69 | 500 | 11.88 | 12.5 | 500 | 19 | 20 | 500 | ns |
| | | Duty Cycle Stabilizer On | ● | 2 | 7.69 | 500 | 2 | 12.5 | 500 | 2 | 20 | 500 | ns |
| t _H | ENC High Time (Note 8) | Duty Cycle Stabilizer Off | ● | 7.3 | 7.69 | 500 | 11.88 | 12.5 | 500 | 19 | 20 | 500 | ns |
| | | Duty Cycle Stabilizer On | ● | 2 | 7.69 | 500 | 2 | 12.5 | 500 | 2 | 20 | 500 | ns |
| t _{AP} | Sample-and-Hold Acquisition Delay Time | | | | 0 | | | 0 | | | 0 | | ns |

| SYMBOL | PARAMETER | CONDITIONS | MIN | TYP | MAX | UNITS |
|---|---------------------|--|-----|-----|----------|------------------|
| Digital Data Outputs (CMOS Modes: Full Data Rate and Double Data Rate) | | | | | | |
| t _D | ENC to Data Delay | C _L = 5pF (Note 8) | ● | 1.1 | 1.7 | 3.1 ns |
| t _C | ENC to CLKOUT Delay | C _L = 5pF (Note 8) | ● | 1 | 1.4 | 2.6 ns |
| t _{SKEW} | DATA to CLKOUT Skew | t _D - t _C (Note 8) | ● | 0 | 0.3 | 0.6 ns |
| | Pipeline Latency | Full Data Rate Mode Double Data Rate Mode | | | 6 6.5 | Cycles Cycles |

LTC2182/LTC2181/LTC2180

TIMING CHARACTERISTICS The ● denotes the specifications which apply over the full operating temperature range, otherwise specifications are at $T_A = 25^\circ\text{C}$. (Note 5)

| SYMBOL | PARAMETER | CONDITIONS | | MIN | TYP | MAX | UNITS |
|---|--|---|---|-----|-----|-----|--------|
| Digital Data Outputs (LVDS Mode) | | | | | | | |
| t_D | ENC to Data Delay | $C_L = 5\text{pF}$ (Note 8) | ● | 1.1 | 1.8 | 3.2 | ns |
| t_C | ENC to CLKOUT Delay | $C_L = 5\text{pF}$ (Note 8) | ● | 1 | 1.5 | 2.7 | ns |
| t_{SKEW} | DATA to CLKOUT Skew | $t_D - t_C$ (Note 8) | ● | 0 | 0.3 | 0.6 | ns |
| | Pipeline Latency | | | | 6.5 | | Cycles |
| SPI Port Timing (Note 8) | | | | | | | |
| t_{SCK} | SCK Period | Write Mode | ● | 40 | | | ns |
| | | Readback Mode, $C_{\text{SDO}} = 20\text{pF}$, $R_{\text{PULLUP}} = 2\text{k}$ | ● | 250 | | | ns |
| t_S | $\overline{\text{CS}}$ to SCK Setup Time | | ● | 5 | | | ns |
| t_H | SCK to $\overline{\text{CS}}$ Setup Time | | ● | 5 | | | ns |
| t_{DS} | SDI Setup Time | | ● | 5 | | | ns |
| t_{DH} | SDI Hold Time | | ● | 5 | | | ns |
| t_{DO} | SCK Falling to SDO Valid | Readback Mode, $C_{\text{SDO}} = 20\text{pF}$, $R_{\text{PULLUP}} = 2\text{k}$ | ● | | | 125 | ns |

Note 1: Stresses beyond those listed under Absolute Maximum Ratings may cause permanent damage to the device. Exposure to any Absolute Maximum Rating condition for extended periods may affect device reliability and lifetime.

Note 2: All voltage values are with respect to GND with GND and OGNND shorted (unless otherwise noted).

Note 3: When these pin voltages are taken below GND or above V_{DD} , they will be clamped by internal diodes. This product can handle input currents of greater than 100mA below GND or above V_{DD} without latchup.

Note 4: When these pin voltages are taken below GND they will be clamped by internal diodes. When these pin voltages are taken above V_{DD} they will not be clamped by internal diodes. This product can handle input currents of greater than 100mA below GND without latchup.

Note 5: $V_{\text{DD}} = 0V_{\text{DD}} = 1.8\text{V}$, $f_{\text{SAMPLE}} = 65\text{MHz}$ (LTC2182), 40MHz (LTC2181), or 25MHz (LTC2180), LVDS outputs, differential $\text{ENC}^+/\text{ENC}^- = 2V_{\text{P-P}}$ sine wave, input range = $2V_{\text{P-P}}$ with differential drive, unless otherwise noted.

Note 6: Integral nonlinearity is defined as the deviation of a code from a best fit straight line to the transfer curve. The deviation is measured from the center of the quantization band.

Note 7: Offset error is the offset voltage measured from -0.5 LSB when the output code flickers between 0000 0000 0000 0000 and 1111 1111 1111 1111 in 2's complement output mode.

Note 8: Guaranteed by design, not subject to test.

Note 9: $V_{\text{DD}} = 1.8\text{V}$, $f_{\text{SAMPLE}} = 65\text{MHz}$ (LTC2182), 40MHz (LTC2181), or 25MHz (LTC2180), CMOS outputs, $\text{ENC}^+ =$ single-ended 1.8V square wave, $\text{ENC}^- = 0\text{V}$, input range = $2V_{\text{P-P}}$ with differential drive, 5pF load on each digital output unless otherwise noted. The supply current and power dissipation specifications are totals for the entire IC, not per channel.

Note 10: Recommended operating conditions.

TIMING DIAGRAMS

Full-Rate CMOS Output Mode Timing
 All Outputs Are Single-Ended and Have CMOS Levels

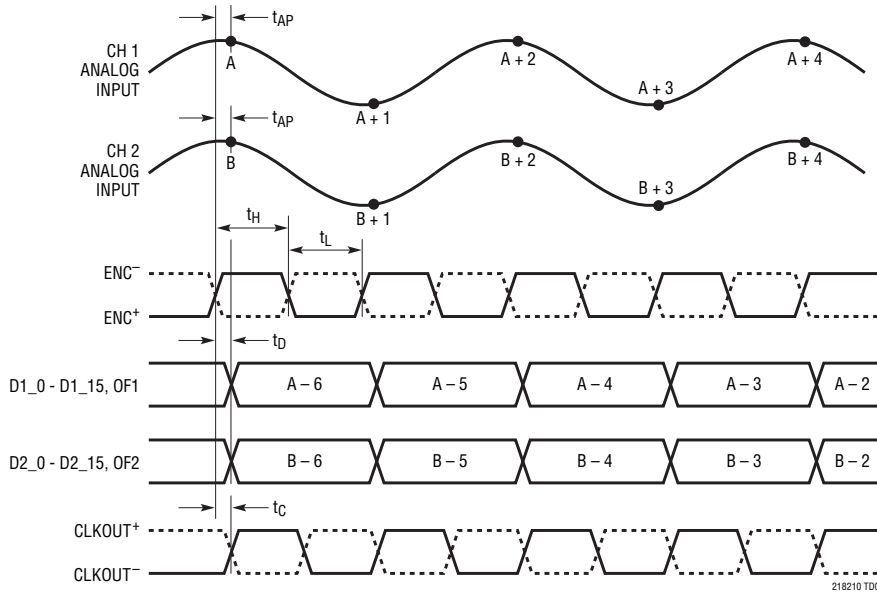

Double Data Rate CMOS Output Mode Timing
 All Outputs Are Single-Ended and Have CMOS Levels

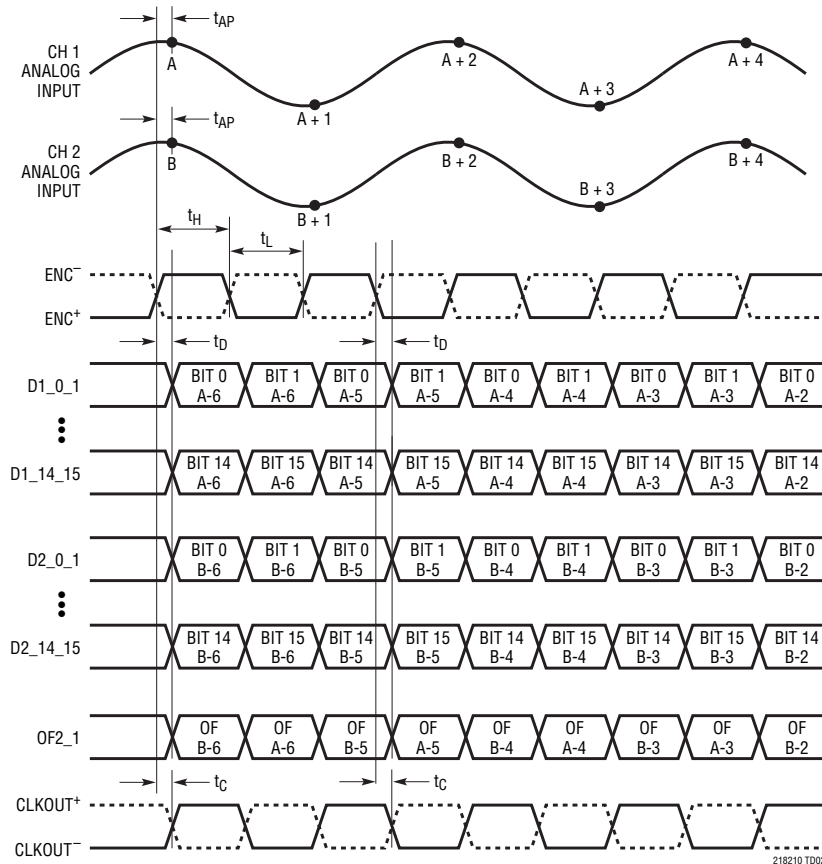

TIMING DIAGRAMS

Double Data Rate LVDS Output Mode Timing
All Outputs Are Differential and Have LVDS Levels

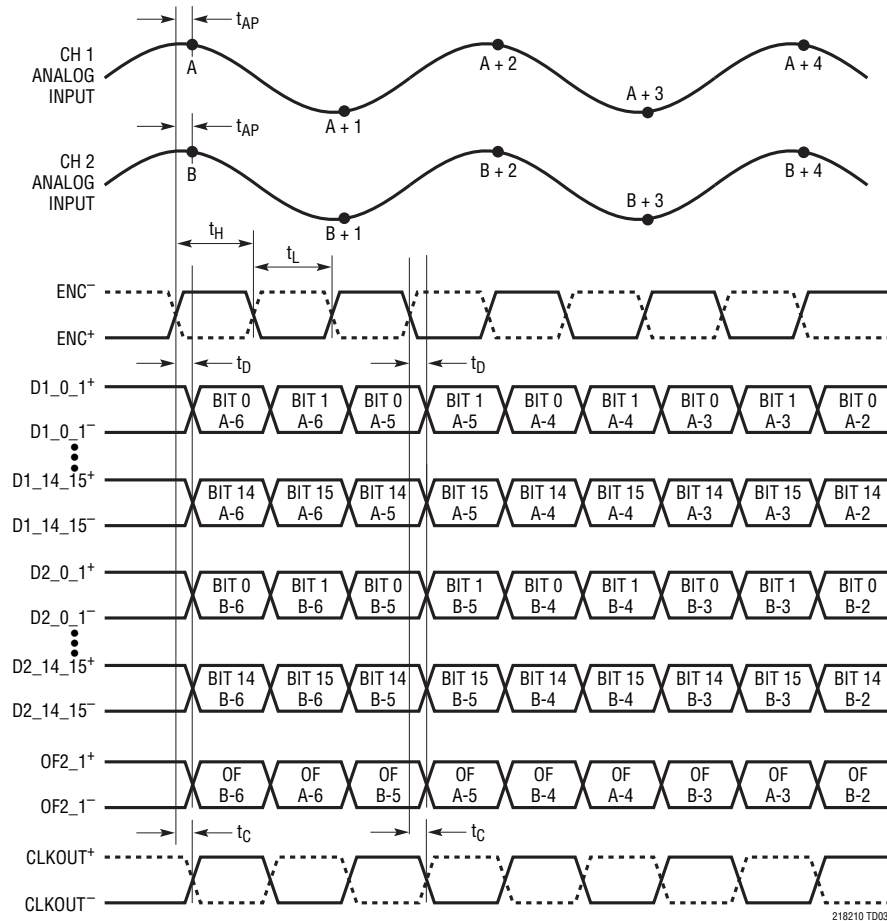

SPI Port Timing (Readback Mode)

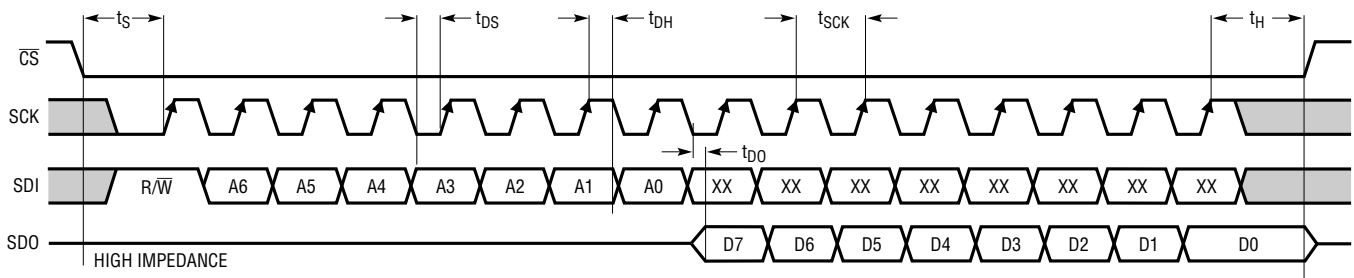

SPI Port Timing (Write Mode)

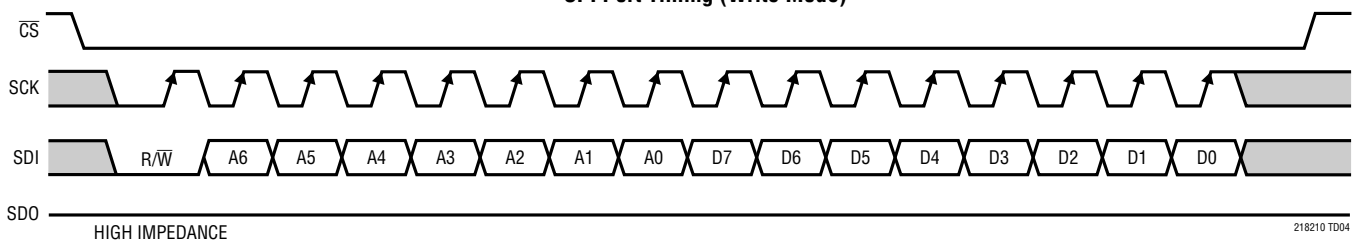

218210 TD04

218210f

TYPICAL PERFORMANCE CHARACTERISTICS

LTC2182: Integral Non-Linearity (INL)

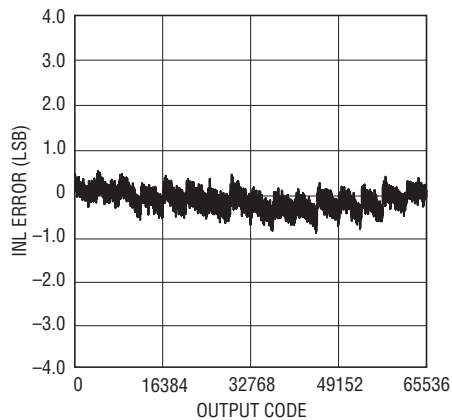

218210 G01

LTC2182: Differential Non-Linearity (DNL)

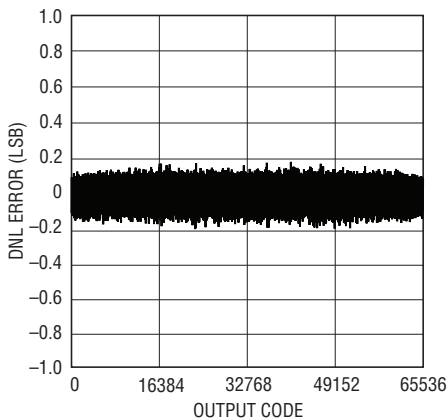

218210 G02

LTC2182: 64k Point FFT, $f_{IN} = 5\text{MHz}$, -1dBFS, 65Mps

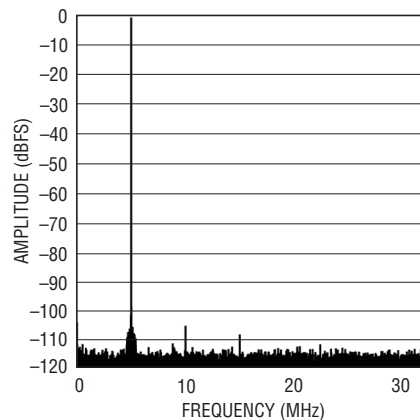

218210 G03

LTC2182: 64k Point FFT, $f_{IN} = 30\text{MHz}$, -1dBFS, 65Mps

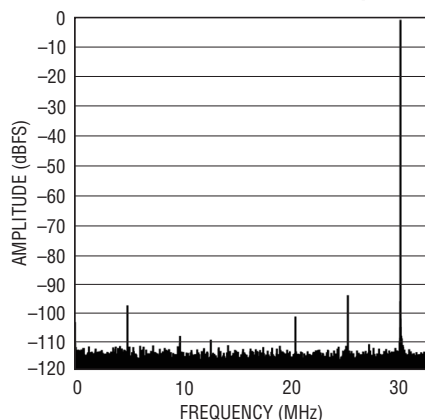

218210 G04

LTC2182: 64k Point FFT, $f_{IN} = 70\text{MHz}$, -1dBFS, 65Mps

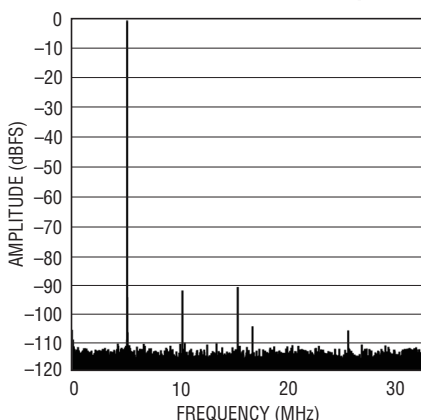

218210 G05

LTC2182: 64k Point FFT, $f_{IN} = 140\text{MHz}$, -1dBFS, 65Mps

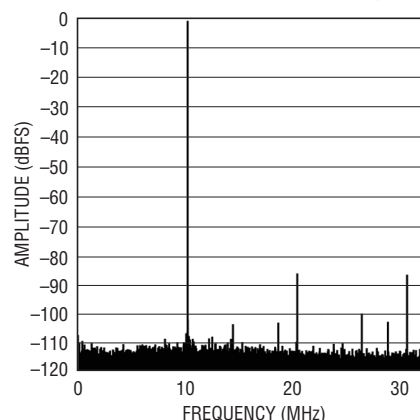

218210 G06

LTC2182: 64k Point 2-Tone FFT, $f_{IN} = 69\text{MHz}$, 70MHz, -7dBFS, 65Mps

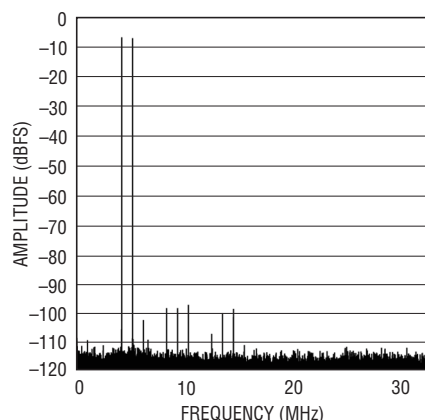

218210 G07

LTC2182: Shorted Input Histogram

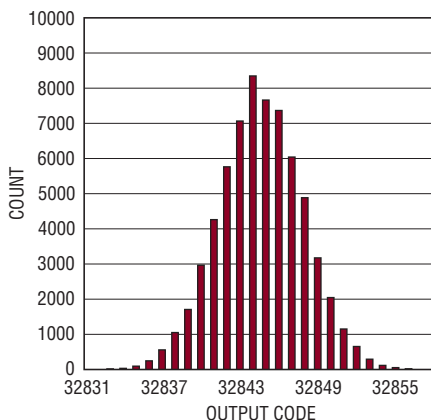

218210 G08

LTC2182: SNR vs Input Frequency, -1dB, 65Mps, 2V Range

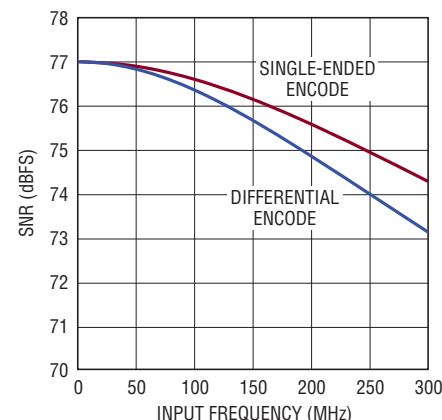

218210 G09

TYPICAL PERFORMANCE CHARACTERISTICS

LTC2182: 2nd, 3rd Harmonic vs Input Frequency, -1dBFS, 65Mps, 2V Range

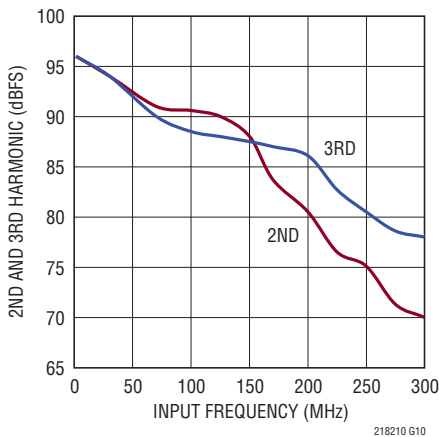

LTC2182: 2nd, 3rd Harmonic vs Input Frequency, -1dBFS, 65Mps, 1V Range

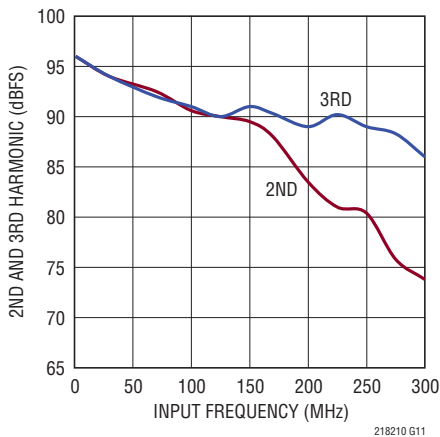

LTC2182: SFDR vs Input Level, $f_{IN} = 70\text{MHz}$, 65Mps, 2V Range

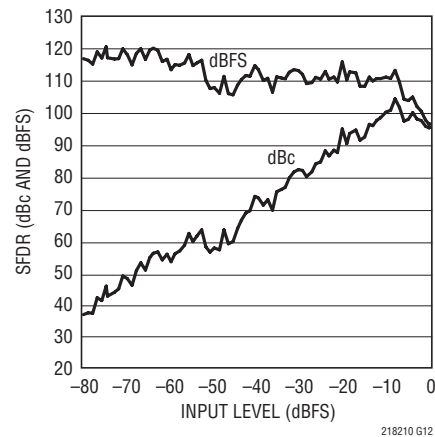

LTC2182: I_{VDD} vs Sample Rate, 5MHz, -1dBFS, Sine Wave Input on Each Channel

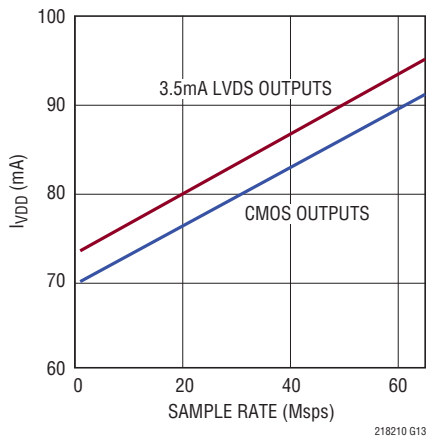

LTC2182: I_{OVD} vs Sample Rate, 5MHz, -1dBFS, Sine Wave Input on Each Channel

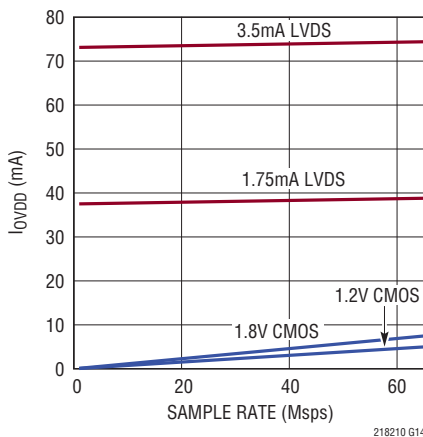

LTC2182: SNR vs SENSE, $f_{IN} = 5\text{MHz}$, -1dBFS

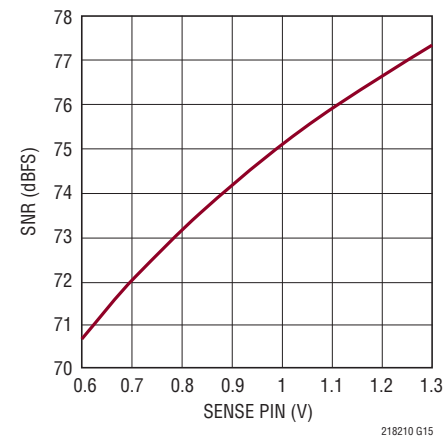

LTC2181: Integral Non-Linearity (INL)

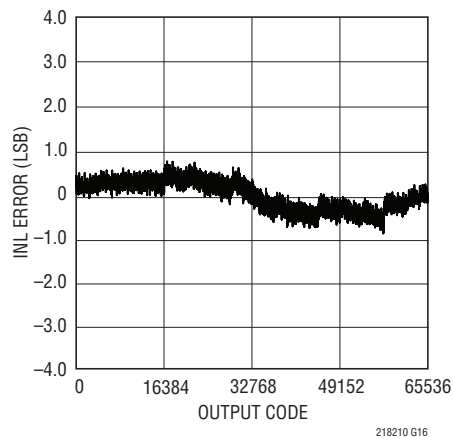

LTC2181: Differential Non-Linearity (DNL)

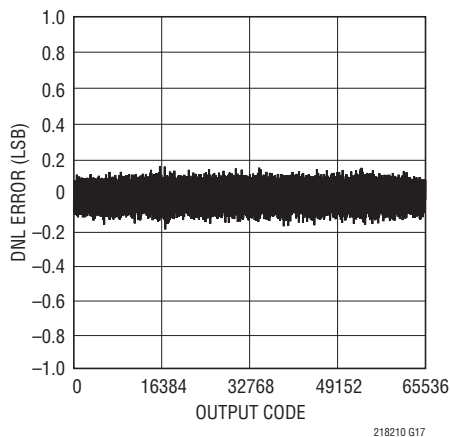

LTC2181: 64k Point FFT, $f_{IN} = 5\text{MHz}$, -1dBFS, 40Mps

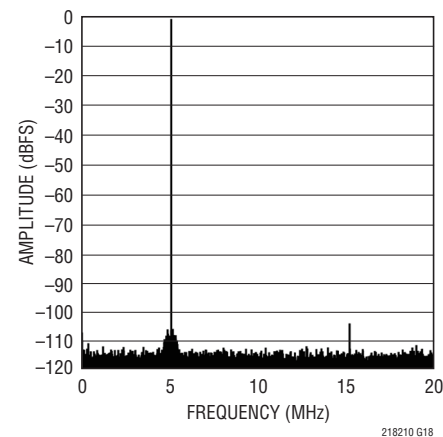

218210f

TYPICAL PERFORMANCE CHARACTERISTICS

**LTC2181: 64k Point FFT,
f_{IN} = 30MHz, -1dBFS, 40Mps**

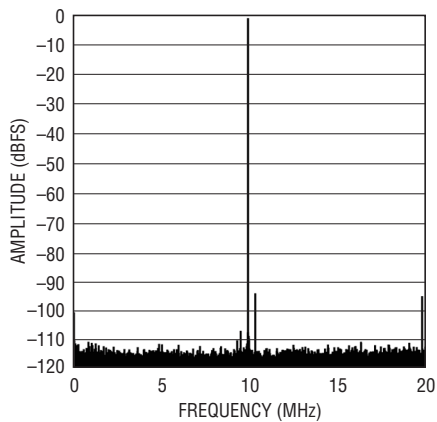

218210 G19

**LTC2181: 64k Point FFT,
f_{IN} = 70MHz, -1dBFS, 40Mps**

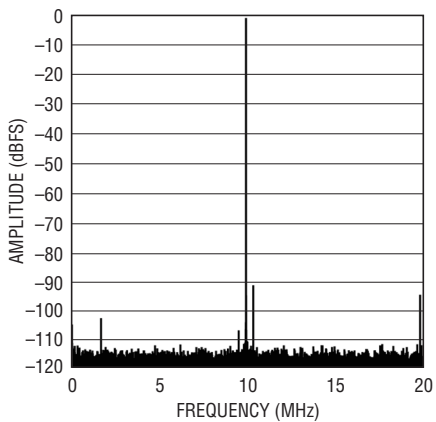

218210 G20

**LTC2181: 64k Point FFT,
f_{IN} = 140MHz, -1dBFS, 40Mps**

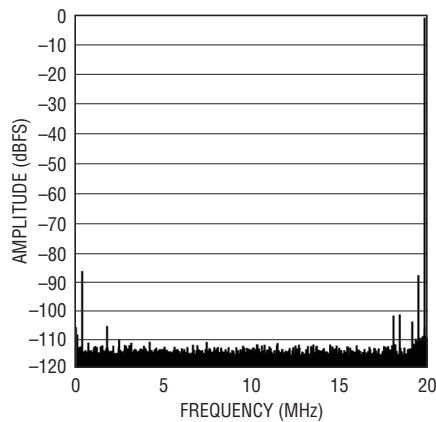

218210 G21

**LTC2181: 64k Point 2-Tone FFT,
f_{IN} = 69MHz, 70MHz, -7dBFS,
40Mps**

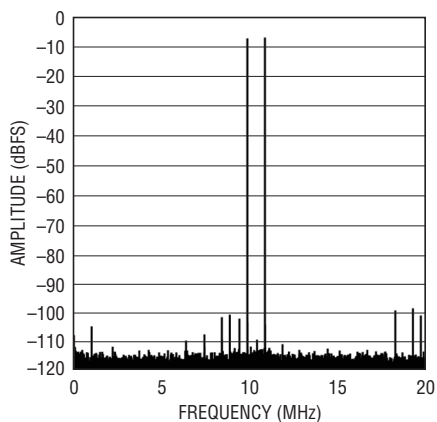

218210 G22

LTC2181: Shorted Input Histogram

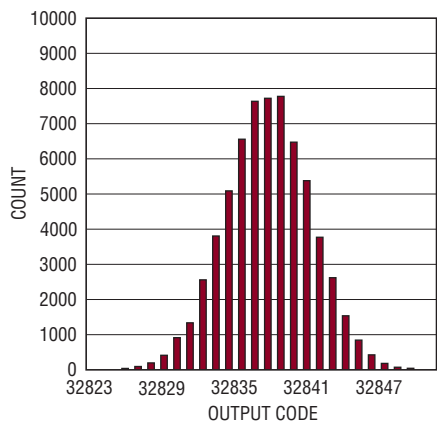

218210 G23

**LTC2181: SNR vs Input Frequency,
-1dBFS, 40Mps, 2V Range**

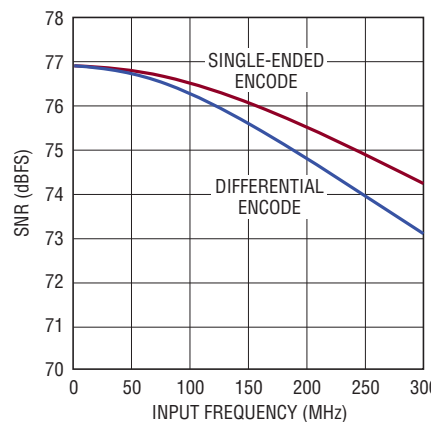

218210 G24

**LTC2181: 2nd, 3rd Harmonic vs
Input Frequency, -1dBFS, 40Mps,
2V Range**

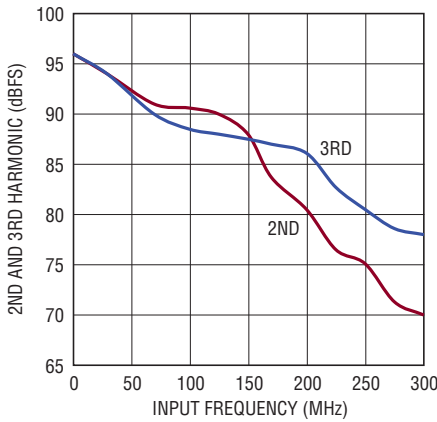

218210 G25

**LTC2181: 2nd, 3rd Harmonic vs
Input Frequency, -1dBFS, 40Mps,
1V Range**

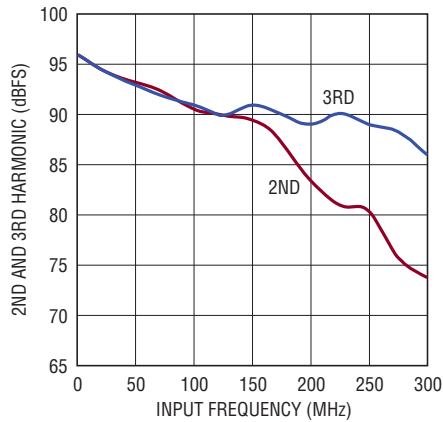

218210 G26

**LTC2181: SFDR vs Input Level,
f_{IN} = 70MHz, 40Mps, 2V Range**

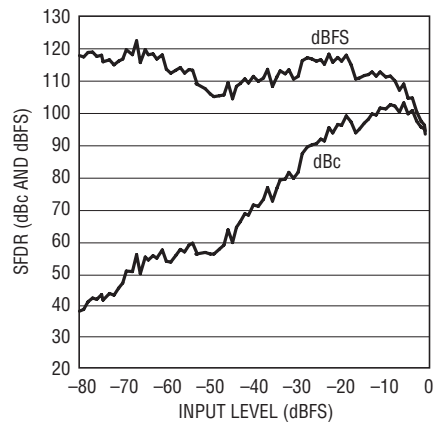

218210 G27

218210f

LTC2182/LTC2181/LTC2180

TYPICAL PERFORMANCE CHARACTERISTICS

LTC2181: I_{VDD} vs Sample Rate, 5MHz, -1dBFS, Sine Wave Input on Each Channel

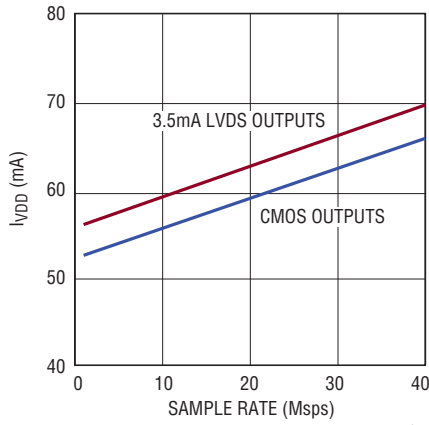

LTC2181: I_{OVD} vs Sample Rate, 5MHz, -1dBFS, Sine Wave Input on Each Channel

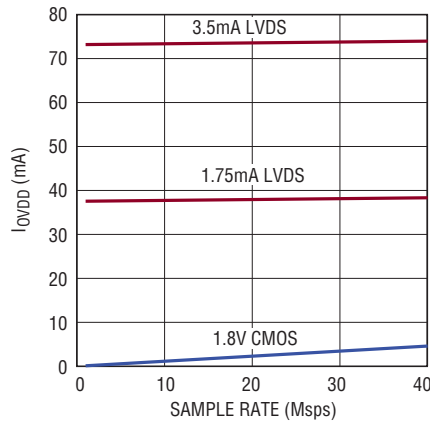

LTC2181: SNR vs SENSE, $f_{IN} = 5\text{MHz}$, -1dBFS

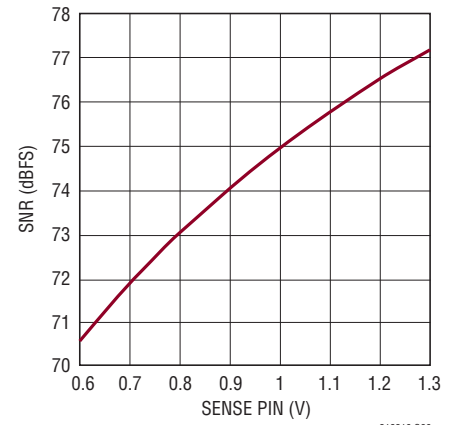

LTC2180: Integral Non-Linearity (INL)

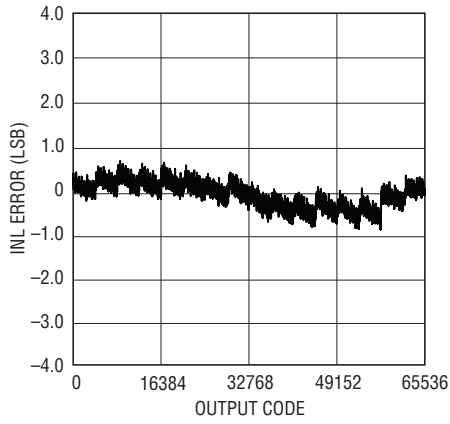

LTC2180: Differential Non-Linearity (DNL)

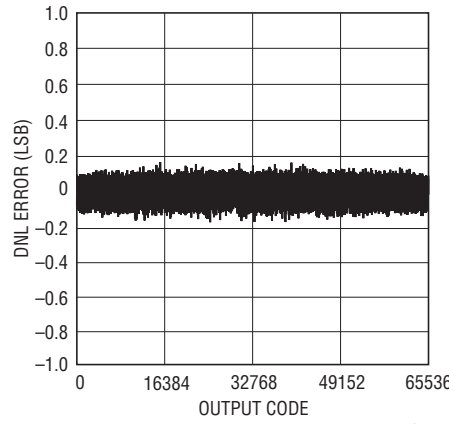

LTC2180: 64k Point FFT, $f_{IN} = 5\text{MHz}$, -1dBFS, 25Msps

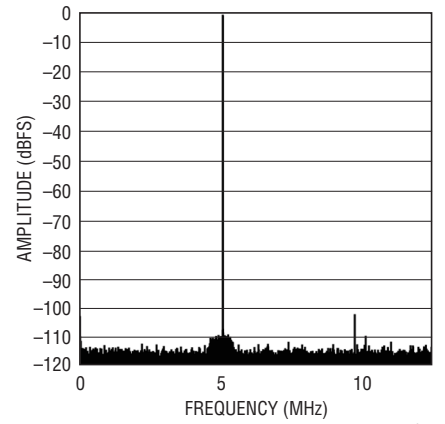

LTC2180: 64k Point FFT, $f_{IN} = 30\text{MHz}$, -1dBFS, 25Msps

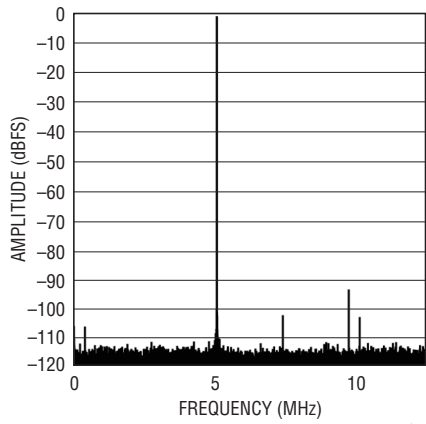

LTC2180: 64k Point FFT, $f_{IN} = 70\text{MHz}$, -1dBFS, 25Msps

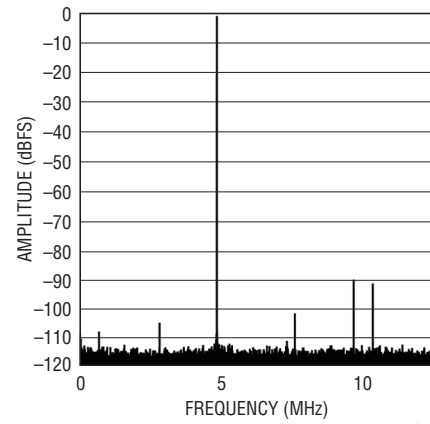

LTC2180: 64k Point FFT, $f_{IN} = 140\text{MHz}$, -1dBFS, 25Msps

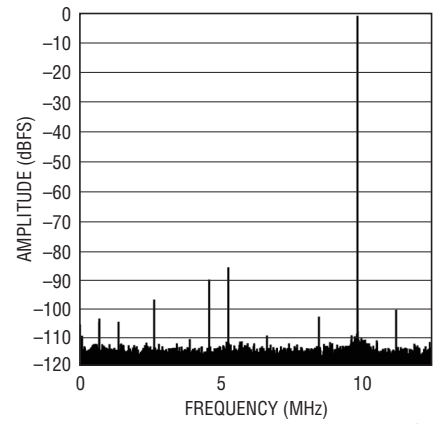

TYPICAL PERFORMANCE CHARACTERISTICS

LTC2180: 64k Point 2-Tone FFT,
 $f_{IN} = 69\text{MHz}$, 70MHz , -7dBFS ,
 25Mpsps

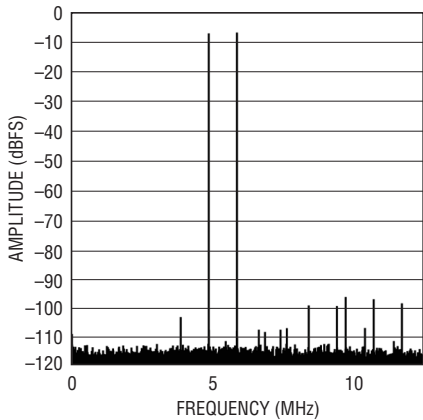

218210 G37

LTC2180: Shorted Input Histogram

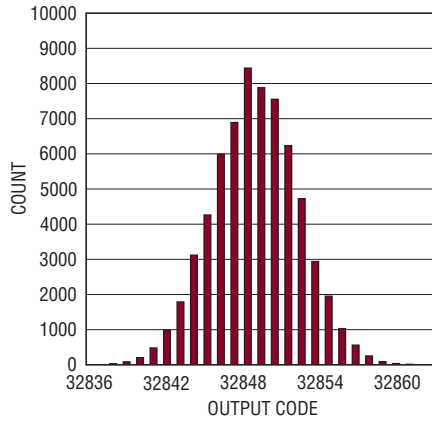

218210 G38

LTC2180: SNR vs Input Frequency,
 -1dBFS , 25Mpsps , 2V Range

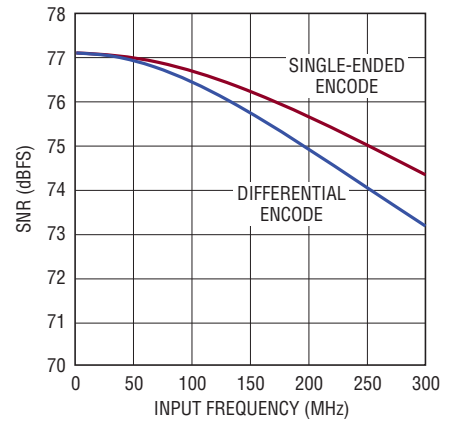

218210 G39

LTC2180: 2nd, 3rd Harmonic vs
Input Frequency, -1dBFS , 25Mpsps ,
 2V Range

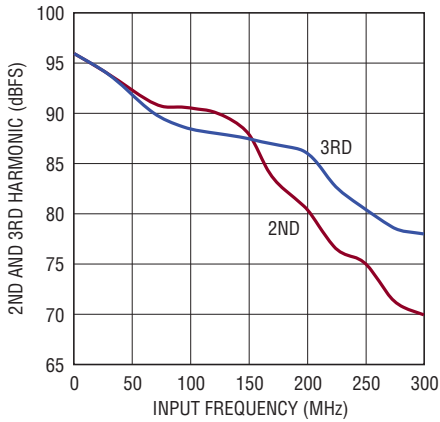

218210 G40

LTC2180: 2nd, 3rd Harmonic vs
Input Frequency, -1dBFS , 25Mpsps ,
 1V Range

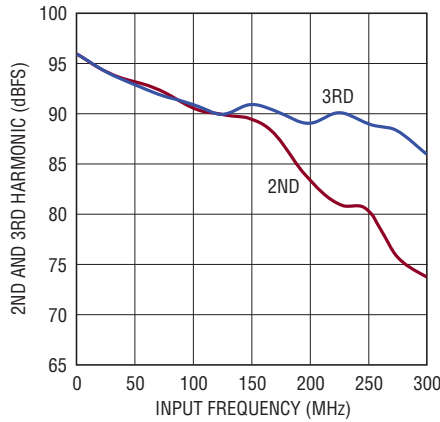

218210 G41

LTC2180: SFDR vs Input Level,
 $f_{IN} = 70\text{MHz}$, 25Mpsps , 2V Range

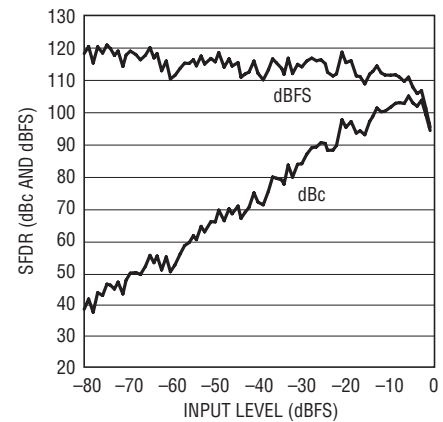

218210 G42

LTC2180: I_{VDD} vs Sample Rate,
 5MHz , -1dBFS , Sine Wave Input
on Each Channel

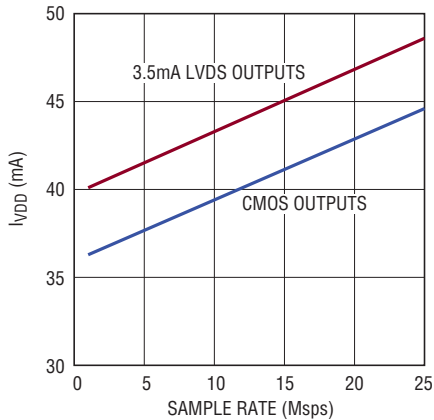

218210 G43

LTC2180: I_{OVPD} vs Sample Rate,
 5MHz , -1dBFS , Sine Wave Input
on Each Channel

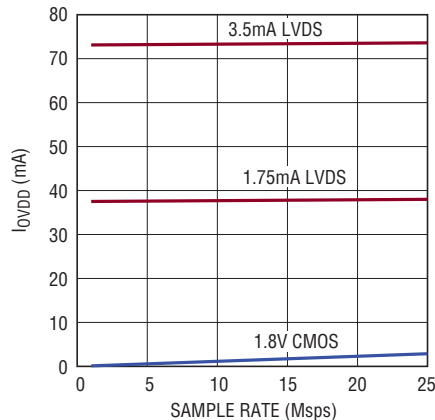

218210 G44

LTC2180: SNR vs SENSE,
 $f_{IN} = 5\text{MHz}$, -1dBFS

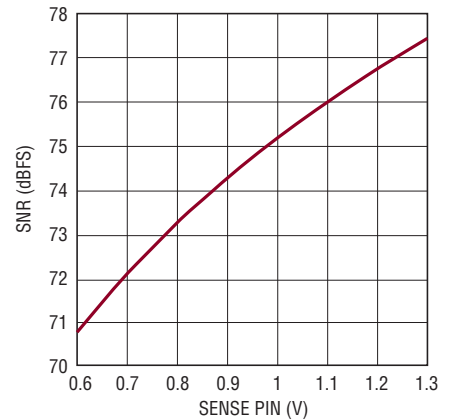

218210 G45

218210f

PIN FUNCTIONS

PINS THAT ARE THE SAME FOR ALL DIGITAL OUTPUT MODES

V_{DD} (Pins 1, 16, 17, 64): Analog Power Supply, 1.7V to 1.9V. Bypass to ground with 0.1 μ F ceramic capacitors. Adjacent pins can share a bypass capacitor.

V_{CM1} (Pin 2): Common Mode Bias Output, nominally equal to V_{DD}/2. V_{CM1} should be used to bias the common mode of the analog inputs to channel 1. Bypass to ground with a 0.1 μ F ceramic capacitor.

GND (Pins 3, 6, 14): ADC Power Ground.

A_{IN1}⁺ (Pin 4): Channel 1 Positive Differential Analog Input.

A_{IN1}⁻ (Pin 5): Channel 1 Negative Differential Analog Input.

REFH (Pins 7, 9): ADC High Reference. See the Applications Information section for recommended bypassing circuits for REFH and REFL.

REFL (Pins 8, 10): ADC Low Reference. See the Applications Information section for recommended bypassing circuits for REFH and REFL.

PAR/ $\overline{\text{SER}}$ (Pin 11): Programming mode selection pin. Connect to ground to enable the serial programming mode. $\overline{\text{CS}}$, SCK, SDI, SDO become a serial interface that control the A/D operating modes. Connect to V_{DD} to enable the parallel programming mode where $\overline{\text{CS}}$, SCK, SDI, SDO become parallel logic inputs that control a reduced set of the A/D operating modes. PAR/ $\overline{\text{SER}}$ should be connected directly to ground or V_{DD} and not be driven by a logic signal.

A_{IN2}⁺ (Pin 12): Channel 2 Positive Differential Analog Input.

A_{IN2}⁻ (Pin 13): Channel 2 Negative Differential Analog Input.

V_{CM2} (Pin 15): Common Mode Bias Output, nominally equal to V_{DD}/2. V_{CM2} should be used to bias the common mode of the analog inputs to channel 2. Bypass to ground with a 0.1 μ F ceramic capacitor.

ENC⁺ (Pin 18): Encode Input. Conversion starts on the rising edge.

ENC⁻ (Pin 19): Encode Complement Input. Conversion starts on the falling edge. Tie to GND for single-ended encode mode.

$\overline{\text{CS}}$ (Pin 20): In serial programming mode, (PAR/ $\overline{\text{SER}}$ = 0V), $\overline{\text{CS}}$ is the Serial Interface Chip Select Input. When $\overline{\text{CS}}$ is low, SCK is enabled for shifting data on SDI into the mode control registers. In the parallel programming mode (PAR/ $\overline{\text{SER}}$ = V_{DD}), $\overline{\text{CS}}$ controls the clock duty cycle stabilizer (See Table 2). $\overline{\text{CS}}$ can be driven with 1.8V to 3.3V logic.

SCK (Pin 21): In serial programming mode, (PAR/ $\overline{\text{SER}}$ = 0V), SCK is the Serial Interface Clock Input. In the parallel programming mode (PAR/ $\overline{\text{SER}}$ = V_{DD}), SCK controls the digital output mode. (See Table 2). SCK can be driven with 1.8V to 3.3V logic.

SDI (Pin 22): In serial programming mode, (PAR/ $\overline{\text{SER}}$ = 0V), SDI is the Serial Interface Data Input. Data on SDI is clocked into the mode control registers on the rising edge of SCK. In the parallel programming mode (PAR/ $\overline{\text{SER}}$ = V_{DD}), SDI can be used together with SDO to power down the part (see Table 2). SDI can be driven with 1.8V to 3.3V logic.

OGND (Pin 41): Output Driver Ground. Must be shorted to the ground plane by a very low inductance path. Use multiple vias close to the pin.

OV_{DD} (Pin 42): Output Driver Supply. Bypass to ground with a 0.1 μ F ceramic capacitor.

SDO (Pin 61): In serial programming mode, (PAR/ $\overline{\text{SER}}$ = 0V), SDO is the optional Serial Interface Data Output. Data on SDO is read back from the mode control registers and can be latched on the falling edge of SCK. SDO is an open-drain NMOS output that requires an external 2k pull-up resistor to 1.8V – 3.3V. If read back from the mode control registers is not needed, the pull-up resistor is not necessary and SDO can be left unconnected. In the parallel programming mode (PAR/ $\overline{\text{SER}}$ = V_{DD}), SDO can be used together with SDI to power down the part (see Table 2). When used as an input, SDO can be driven with 1.8V to 3.3V logic through a 1k series resistor.

V_{REF} (Pin 62): Reference Voltage Output. Bypass to ground with a 2.2 μ F ceramic capacitor. The output voltage is nominally 1.25V.

PIN FUNCTIONS

SENSE (Pin 63): Reference Programming Pin. Connecting SENSE to V_{DD} selects the internal reference and a $\pm 1V$ input range. Connecting SENSE to ground selects the internal reference and a $\pm 0.5V$ input range. An external reference between 0.625V and 1.3V applied to SENSE selects an input range of $\pm 0.8 \cdot V_{SENSE}$.

Ground (Exposed Pad Pin 65): The exposed pad must be soldered to the PCB ground.

FULL-RATE CMOS OUTPUT MODE

All Pins Below Have CMOS Output Levels (OGND to OV_{DD})

D2_0 to D2_15 (Pins 23, 24, 25, 26, 27, 28, 29, 30, 31, 32, 33, 34, 35, 36, 37, 38): Channel 2 Digital Outputs. D2_15 is the MSB.

CLKOUT⁻ (Pin 39): Inverted version of CLKOUT⁺.

CLKOUT⁺ (Pin 40): Data Output Clock. The digital outputs normally transition at the same time as the falling edge of CLKOUT⁺. The phase of CLKOUT⁺ can also be delayed relative to the digital outputs by programming the mode control registers.

D1_0 to D1_15 (Pins 43, 44, 45, 46, 47, 48, 49, 50, 51, 52, 53, 54, 55, 56, 57, 58): Channel 1 Digital Outputs. D1_15 is the MSB.

OF2 (Pin 59): Channel 2 Over/Under Flow Digital Output. OF2 is high when an overflow or underflow has occurred.

OF1 (Pin 60): Channel 1 Over/Under Flow Digital Output. OF1 is high when an overflow or underflow has occurred.

DOUBLE DATA RATE CMOS OUTPUT MODE

All Pins Below Have CMOS Output Levels (OGND to OV_{DD})

D2_0_1 to D2_14_15 (Pins 24, 26, 28, 30, 32, 34, 36, 38): Channel 2 Double Data Rate Digital Outputs. Two data bits are multiplexed onto each output pin. The even data bits (D0, D2, D4, D6, D8, D10, D12, D14) appear when

CLKOUT⁺ is low. The odd data bits (D1, D3, D5, D7, D9, D11, D13, D15) appear when CLKOUT⁺ is high.

DNC (Pins 23, 25, 27, 29, 31, 33, 35, 37, 43, 45, 47, 49, 51, 53, 55, 57, 59): Do not connect these pins.

CLKOUT⁻ (Pin 39): Inverted version of CLKOUT⁺.

CLKOUT⁺ (Pin 40): Data Output Clock. The digital outputs normally transition at the same time as the falling and rising edges of CLKOUT⁺. The phase of CLKOUT⁺ can also be delayed relative to the digital outputs by programming the mode control registers.

D1_0_1 to D1_14_15 (Pins 44, 46, 48, 50, 52, 54, 56, 58): Channel 1 Double Data Rate Digital Outputs. Two data bits are multiplexed onto each output pin. The even data bits (D0, D2, D4, D6, D8, D10, D12, D14) appear when CLKOUT⁺ is low. The odd data bits (D1, D3, D5, D7, D9, D11, D13, D15) appear when CLKOUT⁺ is high.

OF2_1 (Pin 60): Over/Under Flow Digital Output. OF2_1 is high when an overflow or underflow has occurred. The over/under flow for both channels are multiplexed onto this pin. Channel 2 appears when CLKOUT⁺ is low, and Channel 1 appears when CLKOUT⁺ is high.

DOUBLE DATA RATE LVDS OUTPUT MODE

All Pins Below Have LVDS Output Levels. The Output Current Level Is Programmable. There Is an Optional Internal 100 Ω Termination Resistor Between the Pins of Each LVDS Output Pair.

D2_0_1⁻/D2_0_1⁺ to D2_14_15⁻/D2_14_15⁺ (Pins 23/24, 25/26, 27/28, 29/30, 31/32, 33/34, 35/36, 37/38): Channel 2 Double Data Rate Digital Outputs. Two data bits are multiplexed onto each differential output pair. The even data bits (D0, D2, D4, D6, D8, D10, D12, D14) appear when CLKOUT⁺ is low. The odd data bits (D1, D3, D5, D7, D9, D11, D13, D15) appear when CLKOUT⁺ is high.

CLKOUT⁻/CLKOUT⁺ (Pins 39/40): Data Output Clock. The digital outputs normally transition at the same time as the falling and rising edges of CLKOUT⁺. The phase of CLKOUT⁺ can also be delayed relative to the digital outputs by programming the mode control registers.

PIN FUNCTIONS

D1_0_1⁻/D1_0_1⁺ to D1_14_15⁻/D1_14_15⁺ (Pins 43/44, 45/46, 47/48, 49/50, 51/52, 53/54, 55/56, 57/58): Channel 2 Double Data Rate Digital Outputs. Two data bits are multiplexed onto each differential output pair. The even data bits (D0, D2, D4, D6, D8, D10, D12, D14) appear when CLKOUT⁺ is low, and Channel 1 appears when CLKOUT⁺ is high. The odd data bits (D1, D3, D5, D7, D9, D11, D13, D15) appear when CLKOUT⁺ is high.

OF2_1⁻/OF2_1⁺ (Pins 59/60): Over/Under Flow Digital Output. OF2_1⁺ is high when an overflow or underflow has occurred. The over/under flow for both channels are multiplexed onto this pin. Channel 2 appears when CLKOUT⁺ is low, and Channel 1 appears when CLKOUT⁺ is high.

FUNCTIONAL BLOCK DIAGRAM

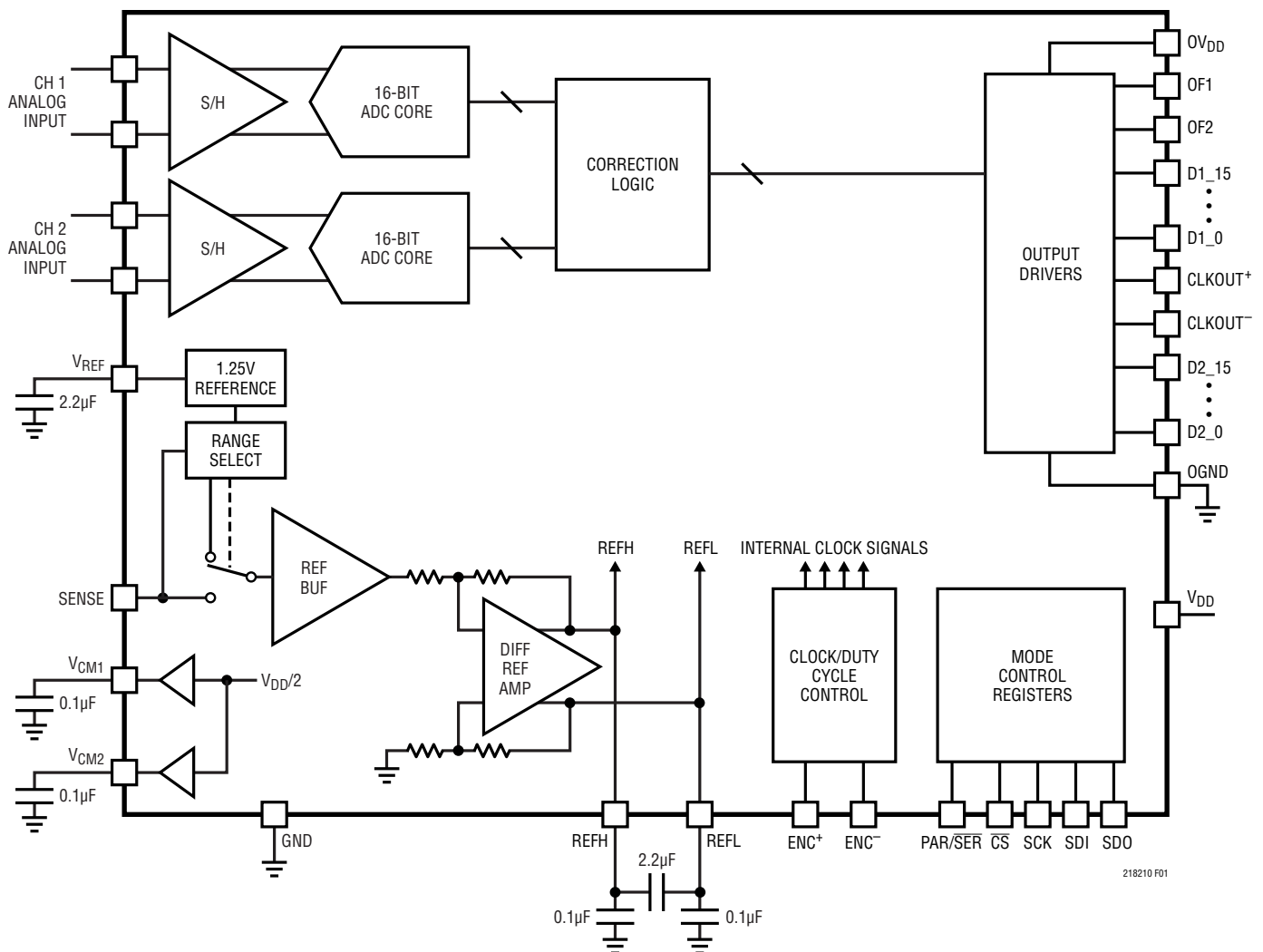

Figure 1. Functional Block Diagram

APPLICATIONS INFORMATION

CONVERTER OPERATION

The LTC2182/LTC2181/LTC2180 are low power, two-channel, 16-bit, 65Msps/40Msps/25Msps A/D converters that are powered by a single 1.8V supply. The analog inputs should be driven differentially. The encode input can be driven differentially, or single ended for lower power consumption. The digital outputs can be CMOS, double data rate CMOS (to halve the number of output lines), or double data rate LVDS (to reduce digital noise in the system.) Many additional features can be chosen by programming the mode control registers through a serial SPI port.

ANALOG INPUT

The analog inputs are differential CMOS sample-and-hold circuits (Figure 2). The inputs should be driven differentially around a common mode voltage set by the V_{CM1} or V_{CM2} output pins, which are nominally $V_{DD}/2$. For the 2V input range, the inputs should swing from $V_{CM} - 0.5V$ to $V_{CM} + 0.5V$. There should be 180° phase difference between the inputs.

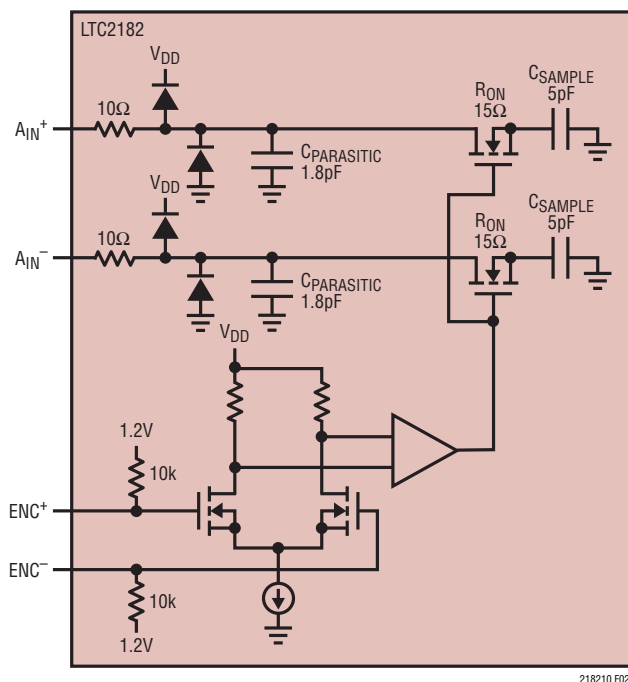

Figure 2. Equivalent Input Circuit. Only One of the Two Analog Channels Is Shown

The two channels are simultaneously sampled by a shared encode circuit (Figure 2).

Single-Ended Input

For applications less sensitive to harmonic distortion, the A_{IN}^+ input can be driven single-ended with a $1V_{P-P}$ signal centered around V_{CM} . The A_{IN}^- input should be connected to V_{CM} and the V_{CM} bypass capacitor should be increased to $2.2\mu F$. With a single-ended input the harmonic distortion and INL will degrade, but the noise and DNL will remain unchanged.

INPUT DRIVE CIRCUITS

Input filtering

If possible, there should be an RC lowpass filter right at the analog inputs. This lowpass filter isolates the drive circuitry from the A/D sample-and-hold switching, and also limits wideband noise from the drive circuitry. Figure 3 shows an example of an input RC filter. The RC component values should be chosen based on the application's input frequency.

Transformer Coupled Circuits

Figure 3 shows the analog input being driven by an RF transformer with a center-tapped secondary. The center tap is biased with V_{CM} , setting the A/D input at its optimal DC level. At higher input frequencies a transmission line balun transformer (Figure 4 to Figure 6) has better balance, resulting in lower A/D distortion.

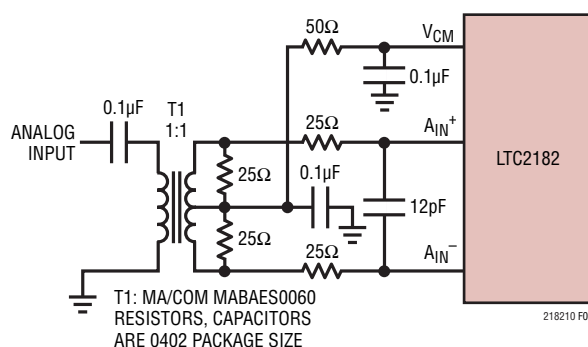

Figure 3. Analog Input Circuit Using a Transformer. Recommended for Input Frequencies from 5MHz to 70MHz

APPLICATIONS INFORMATION

Amplifier Circuits

Figure 7 shows the analog input being driven by a high speed differential amplifier. The output of the amplifier is AC-coupled to the A/D so the amplifier's output common mode voltage can be optimally set to minimize distortion.

At very high frequencies an RF gain block will often have lower distortion than a differential amplifier. If the gain block is single-ended, then a transformer circuit (Figure 4 to Figure 6) should convert the signal to differential before driving the A/D.

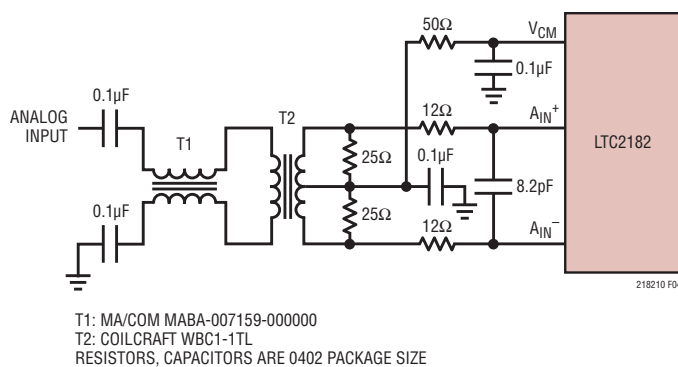

Figure 4. Recommended Front-End Circuit for Input Frequencies from 5MHz to 150MHz

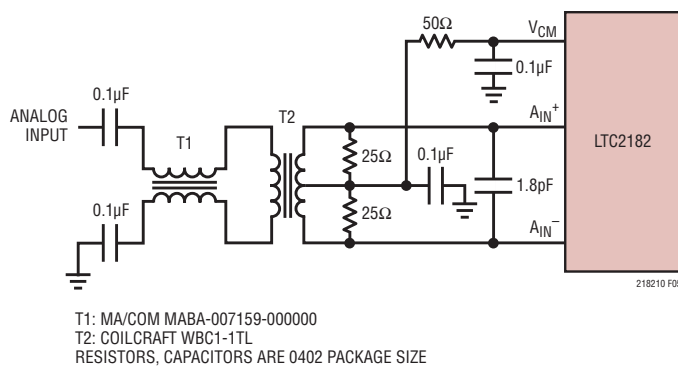

Figure 5. Recommended Front-End Circuit for Input Frequencies from 150MHz to 250MHz

Reference

The LTC2182/LTC2181/LTC2180 has an internal 1.25V voltage reference. For a 2V input range using the internal reference, connect SENSE to V_{DD} . For a 1V input range using the internal reference, connect SENSE to ground. For a 2V input range with an external reference, apply a 1.25V reference voltage to SENSE (Figure 9).

The input range can be adjusted by applying a voltage to SENSE that is between 0.625V and 1.30V. The input range will then be $1.6 \cdot V_{SENSE}$.

The V_{REF} , REFH and REFL pins should be bypassed as shown in Figure 8. A low inductance 2.2μF interdigitated capacitor is recommended for the bypass between REFH and REFL. This type of capacitor is available at a low cost from multiple suppliers.

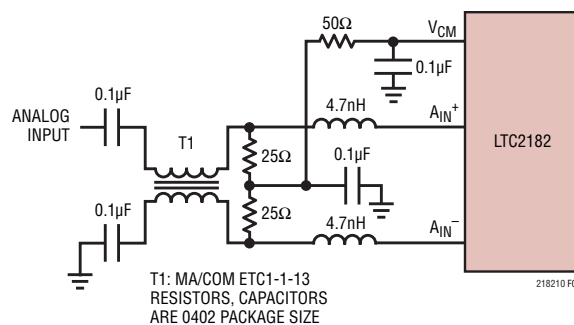

Figure 6. Recommended Front-End Circuit for Input Frequencies Above 250MHz

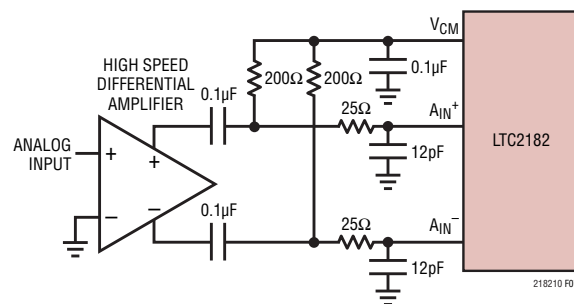

Figure 7. Front-End Circuit Using a High Speed Differential Amplifier

APPLICATIONS INFORMATION

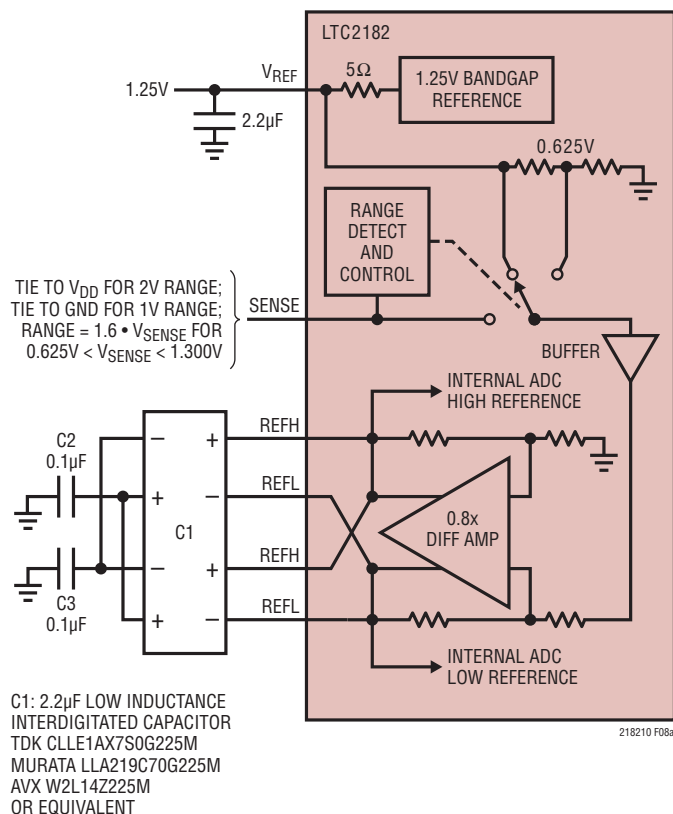

Figure 8a. Reference Circuit

Alternatively C1 can be replaced by a standard 2.2μF capacitor between REFH and REFL (see Figure 8b). The capacitors should be as close to the pins as possible (not on the back side of the circuit board).

Figure 8c and Figure 8d show the recommended circuit board layout for the REFH/REFL bypass capacitors. Note that in Figure 8c, every pin of the interdigitated capacitor (C1) is connected since the pins are not internally connected in some vendors' capacitors. In Figure 8d the REFH and

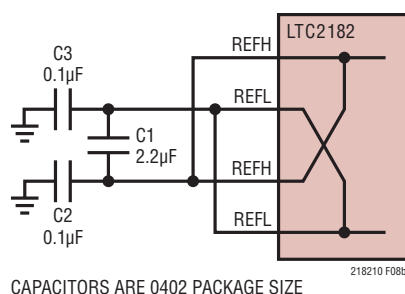

Figure 8b. Alternative REFH/REFL Bypass Circuit

REFL pins are connected by short jumpers in an internal layer. To minimize the inductance of these jumpers they can be placed in a small hole in the GND plane on the second board layer.

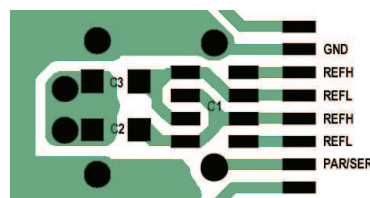

Figure 8c. Recommended Layout for the REFH/REFL Bypass Circuit in Figure 8a

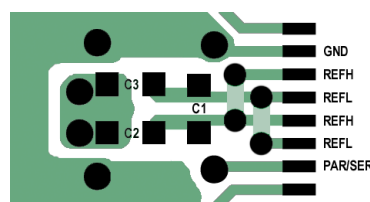

Figure 8d. Recommended Layout for the REFH/REFL Bypass Circuit in Figure 8b

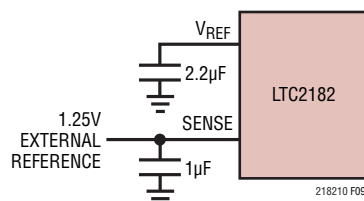

Figure 9. Using an External 1.25V Reference

Encode Inputs

The signal quality of the encode inputs strongly affects the A/D noise performance. The encode inputs should be treated as analog signals – do not route them next to digital traces on the circuit board. There are two modes of operation for the encode inputs: the differential encode mode (Figure 10), and the single-ended encode mode (Figure 11).

The differential encode mode is recommended for sinusoidal, PECL, or LVDS encode inputs (Figure 12 and Figure 13). The encode inputs are internally biased to 1.2V through 10kΩ equivalent resistance. The encode inputs can be taken above V_{DD} (up to 3.6V), and the common mode range is from 1.1V to 1.6V. In the differential encode

APPLICATIONS INFORMATION

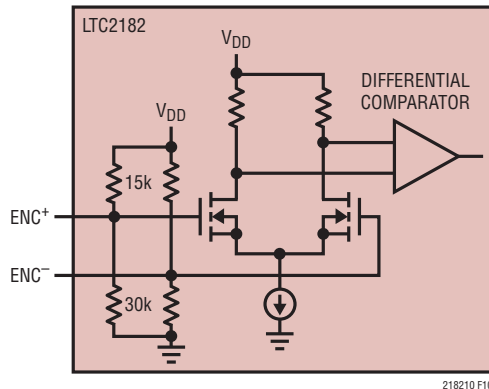

Figure 10. Equivalent Encode Input Circuit for Differential Encode Mode

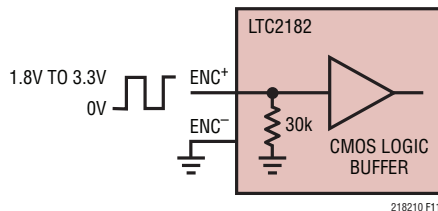

Figure 11. Equivalent Encode Input Circuit for Single-Ended Encode Mode

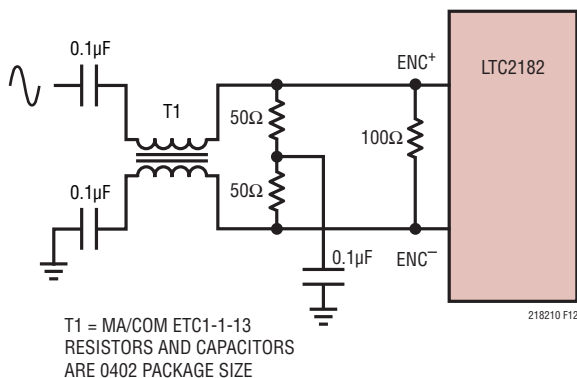

Figure 12. Sinusoidal Encode Drive

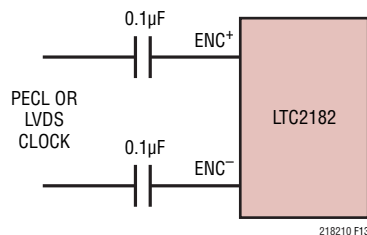

Figure 13. PECL or LVDS Encode Drive

mode, ENC^- should stay at least 200mV above ground to avoid falsely triggering the single ended encode mode. For good jitter performance ENC^+ and ENC^- should have fast rise and fall times.

The single-ended encode mode should be used with CMOS encode inputs. To select this mode, ENC^- is connected to ground and ENC^+ is driven with a square wave encode input. ENC^+ can be taken above V_{DD} (up to 3.6V) so 1.8V to 3.3V CMOS logic levels can be used. The ENC^+ threshold is 0.9V. For good jitter performance ENC^+ should have fast rise and fall times.

If the encode signal is turned off or drops below approximately 500kHz, the A/D enters nap mode.

Clock Duty Cycle Stabilizer

For good performance the encode signal should have a 50% ($\pm 5\%$) duty cycle. If the optional clock duty cycle stabilizer circuit is enabled, the encode duty cycle can vary from 30% to 70% and the duty cycle stabilizer will maintain a constant 50% internal duty cycle. If the encode signal changes frequency, the duty cycle stabilizer circuit requires one hundred clock cycles to lock onto the input clock. The duty cycle stabilizer is enabled by mode control register A2 (serial programming mode), or by \overline{CS} (parallel programming mode).

For applications where the sample rate needs to be changed quickly, the clock duty cycle stabilizer can be disabled. If the duty cycle stabilizer is disabled, care should be taken to make the sampling clock have a 50% ($\pm 5\%$) duty cycle. The duty cycle stabilizer should not be used below 5MSPS.

DIGITAL OUTPUTS

Digital Output Modes

The LTC2182/LTC2181/LTC2180 can operate in three digital output modes: full rate CMOS, double data rate CMOS (to halve the number of output lines), or double data rate LVDS (to reduce digital noise in the system.) The output mode is set by mode control register A3 (serial programming mode), or by SCK (parallel programming mode). Note that double data rate CMOS cannot be selected in the parallel programming mode.

APPLICATIONS INFORMATION

Full Rate CMOS Mode

In full rate CMOS mode the data outputs (D1_0 to D1_15 and D2_0 to D2_15), overflow (OF2, OF1), and the data output clocks (CLKOUT+, CLKOUT-) have CMOS output levels. The outputs are powered by OV_{DD} and OGND which are isolated from the A/D core power and ground. OV_{DD} can range from 1.1V to 1.9V, allowing 1.2V through 1.8V CMOS logic outputs.

For good performance the digital outputs should drive minimal capacitive loads. If the load capacitance is larger than 10pF a digital buffer should be used.

Double Data Rate CMOS Mode

In Double Data Rate CMOS mode, two data bits are multiplexed and output on each data pin. This reduces the number of digital lines by seventeen, simplifying board routing and reducing the number of input pins needed to receive the data. The data outputs (D1_0_1, D1_2_3, D1_4_5, D1_6_7, D1_8_9, D1_10_11, D1_12_13, D1_14_15, D2_0_1, D2_2_3, D2_4_5, D2_6_7, D2_8_9, D2_10_11, D2_12_13, D2_14_15), overflow (OF2_1), and the data output clocks (CLKOUT+, CLKOUT-) have CMOS output levels. The outputs are powered by OV_{DD} and OGND which are isolated from the A/D core power and ground. OV_{DD} can range from 1.1V to 1.9V, allowing 1.2V through 1.8V CMOS logic outputs. Note that the overflow for both ADC channels is multiplexed onto the OF2_1 pin.

For good performance the digital outputs should drive minimal capacitive loads. If the load capacitance is larger than 10pF a digital buffer should be used.

Double Data Rate LVDS Mode

In double data rate LVDS mode, two data bits are multiplexed and output on each differential output pair. There are eight LVDS output pairs per ADC channel (D1_0_1+/D1_0_1- through D1_14_15+/D1_14_15- and D2_0_1+/D2_0_1- through D2_14_15+/D2_14_15-) for the digital output data. Overflow (OF2_1+/OF2_1-) and the data

output clock (CLKOUT+/CLKOUT-) each have an LVDS output pair. Note that the overflow for both ADC channels is multiplexed onto the OF2_1+/OF2_1- output pair.

By default the outputs are standard LVDS levels: 3.5mA output current and a 1.25V output common mode voltage. An external 100 Ω differential termination resistor is required for each LVDS output pair. The termination resistors should be located as close as possible to the LVDS receiver.

The outputs are powered by OV_{DD} and OGND which are isolated from the A/D core power and ground. In LVDS mode, OV_{DD} must be 1.8V.

Programmable LVDS Output Current

In LVDS mode, the default output driver current is 3.5mA. This current can be adjusted by serially programming mode control register A3. Available current levels are 1.75mA, 2.1mA, 2.5mA, 3mA, 3.5mA, 4mA and 4.5mA.

Optional LVDS Driver Internal Termination

In most cases using just an external 100 Ω termination resistor will give excellent LVDS signal integrity. In addition, an optional internal 100 Ω termination resistor can be enabled by serially programming mode control register A3. The internal termination helps absorb any reflections caused by imperfect termination at the receiver. When the internal termination is enabled, the output driver current is doubled to maintain the same output voltage swing.

Overflow Bit

The overflow output bit outputs a logic high when the analog input is either over-ranged or under-ranged. The overflow bit has the same pipeline latency as the data bits. In Full-Rate CMOS mode each ADC channel has its own overflow pin (OF1 for channel 1, OF2 for channel 2). In DDR CMOS or DDR LVDS mode the overflow for both ADC channels is multiplexed onto the OF2_1 output.

APPLICATIONS INFORMATION

Phase Shifting the Output Clock

In Full Rate CMOS mode the data output bits normally change at the same time as the falling edge of CLKOUT⁺, so the rising edge of CLKOUT⁺ can be used to latch the output data. In Double Data Rate CMOS and LVDS modes the data output bits normally change at the same time as the falling and rising edges of CLKOUT⁺. To allow adequate set-up and hold time when latching the data, the CLKOUT⁺ signal may need to be phase shifted relative to the data output bits. Most FPGAs have this feature; this is generally the best place to adjust the timing.

The LTC2182/LTC2181/LTC2180 can also phase shift the CLKOUT⁺/CLKOUT⁻ signals by serially programming mode control register A2. The output clock can be shifted by 0°, 45°, 90°, or 135°. To use the phase shifting feature the clock duty cycle stabilizer must be turned on. Another control register bit can invert the polarity of CLKOUT⁺ and CLKOUT⁻, independently of the phase shift. The combination of these two features enables phase shifts of 45° up to 315° (Figure 14).

DATA FORMAT

Table 1 shows the relationship between the analog input voltage, the digital data output bits and the overflow bit. By default the output data format is offset binary. The 2's complement format can be selected by serially programming mode control register A4.

Table 1. Output Codes vs Input Voltage

| A _{IN} ⁺ – A _{IN} ⁻ (2V Range) | OF | D15-D0 (OFFSET BINARY) | D15-D0 (2's COMPLEMENT) |
|---|----|---------------------------|----------------------------|
| >1.000000V | 1 | 1111 1111 1111 1111 | 0111 1111 1111 1111 |
| +0.999970V | 0 | 1111 1111 1111 1111 | 0111 1111 1111 1111 |
| +0.999939V | 0 | 1111 1111 1111 1110 | 0111 1111 1111 1110 |
| +0.000030V | 0 | 1000 0000 0000 0001 | 0000 0000 0000 0001 |
| +0.000000V | 0 | 1000 0000 0000 0000 | 0000 0000 0000 0000 |
| -0.000030V | 0 | 0111 1111 1111 1111 | 1111 1111 1111 1111 |
| -0.000061V | 0 | 0111 1111 1111 1110 | 1111 1111 1111 1110 |
| -0.999939V | 0 | 0000 0000 0000 0001 | 1000 0000 0000 0001 |
| -1.000000V | 0 | 0000 0000 0000 0000 | 1000 0000 0000 0000 |
| <-1.000000V | 1 | 0000 0000 0000 0000 | 1000 0000 0000 0000 |

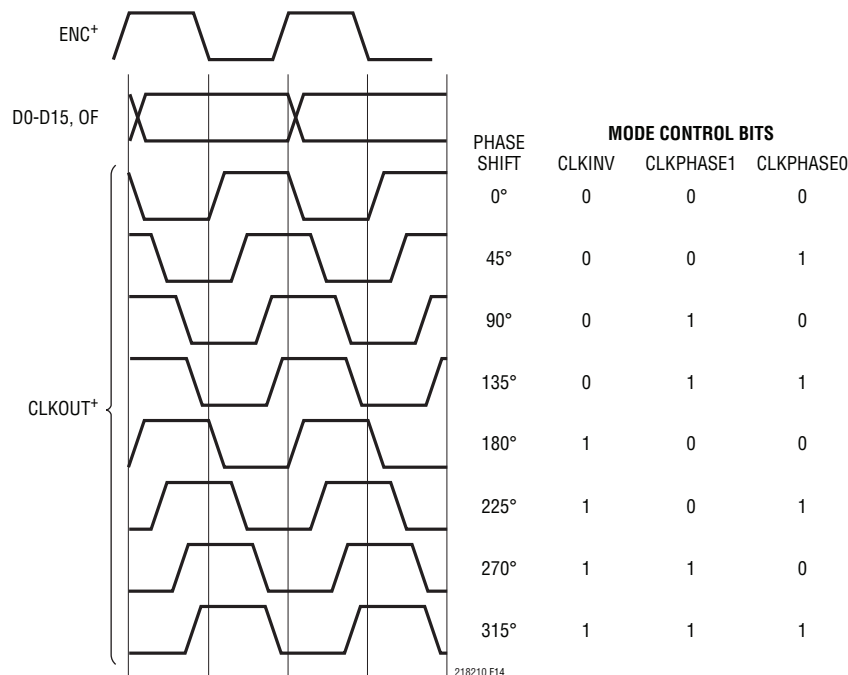

Figure 14. Phase Shifting CLKOUT

APPLICATIONS INFORMATION

Digital Output Randomizer

Interference from the A/D digital outputs is sometimes unavoidable. Digital interference may be from capacitive or inductive coupling or coupling through the ground plane. Even a tiny coupling factor can cause unwanted tones in the ADC output spectrum. By randomizing the digital output before it is transmitted off chip, these unwanted tones can be randomized which reduces the unwanted tone amplitude.

The digital output is randomized by applying an exclusive-OR logic operation between the LSB and all other data output bits. To decode, the reverse operation is applied – an exclusive-OR operation is applied between the LSB and all other bits. The LSB, OF and CLKOUT outputs are not affected. The output randomizer is enabled by serially programming mode control register A4.

Alternate Bit Polarity

Another feature that reduces digital feedback on the circuit board is the alternate bit polarity mode. When this mode is enabled, all of the odd bits (D1, D3, D5, D7, D9, D11, D13, D15) are inverted before the output buffers. The even bits (D0, D2, D4, D6, D8, D10, D12, D14), OF and CLKOUT are not affected. This can reduce digital currents in the circuit board ground plane and reduce digital noise, particularly for very small analog input signals.

When there is a very small signal at the input of the A/D that is centered around mid-scale, the digital outputs toggle between mostly 1's and mostly 0's. This simultaneous switching of most of the bits will cause large currents in the ground plane. By inverting every other bit, the alternate bit polarity mode makes half of the bits transition high while half of the bits transition low. This cancels current flow in the ground plane, reducing the digital noise.

The digital output is decoded at the receiver by inverting the odd bits (D1, D3, D5, D7, D9, D11, D13, D15.) The alternate bit polarity mode is independent of the digital output randomizer – either, both or neither function can be on at the same time. The alternate bit polarity mode is enabled by serially programming mode control register A4.

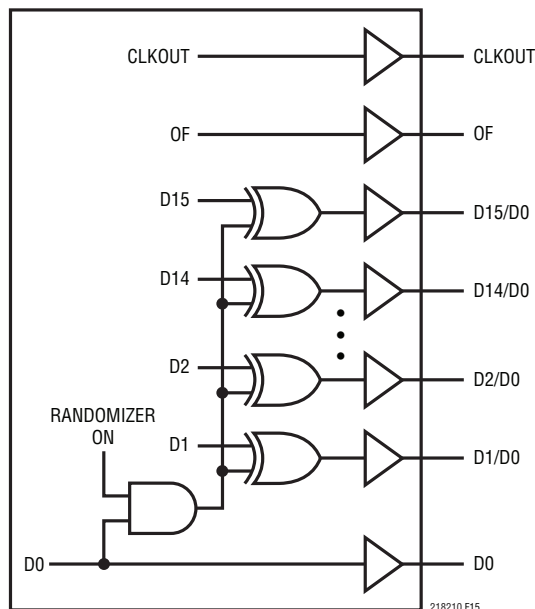

Figure 15. Functional Equivalent of Digital Output Randomizer

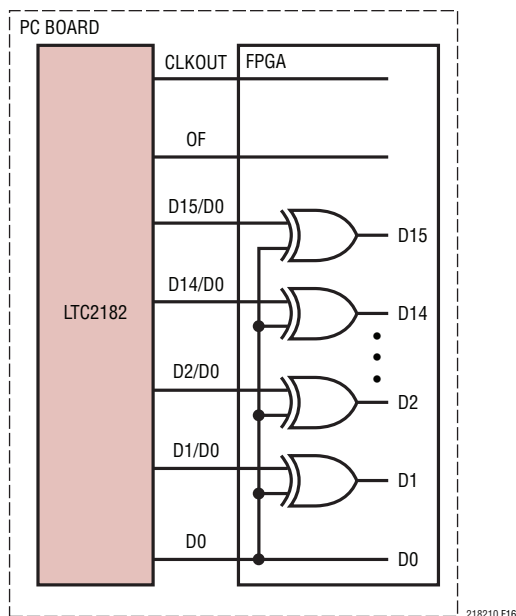

Figure 16. Unrandomizing a Randomized Digital Output Signal