



Chipsmall Limited consists of a professional team with an average of over 10 year of expertise in the distribution of electronic components. Based in Hongkong, we have already established firm and mutual-benefit business relationships with customers from,Europe,America and south Asia,supplying obsolete and hard-to-find components to meet their specific needs.

With the principle of "Quality Parts,Customers Priority,Honest Operation,and Considerate Service",our business mainly focus on the distribution of electronic components. Line cards we deal with include Microchip,ALPS,ROHM,Xilinx,Pulse,ON,Everlight and Freescale. Main products comprise IC,Modules,Potentiometer,IC Socket,Relay,Connector.Our parts cover such applications as commercial,industrial, and automotives areas.

We are looking forward to setting up business relationship with you and hope to provide you with the best service and solution. Let us make a better world for our industry!



## Contact us

Tel: +86-755-8981 8866 Fax: +86-755-8427 6832

Email & Skype: info@chipsmall.com Web: www.chipsmall.com

Address: A1208, Overseas Decoration Building, #122 Zhenhua RD., Futian, Shenzhen, China





# Through Hole Lamp Product Data Sheet LTL2P3TBU2KS

Spec No.: DS20-2013-0092

Effective Date: 06/15/2013

Revision: -

**LITE-ON DCC**

**RELEASE**

BNS-OD-FC001/A4

## Features

- \* High luminous intensity output.
- \* Low power consumption.
- \* High efficiency.
- \* Versatile mounting on P.C. board or panel.
- \* I.C. Compatible/low current requirements.
- \* Popular T-1 3/4 diameter.
- \* Lead (Pb) free product – RoHS compliant.

## Package Dimensions

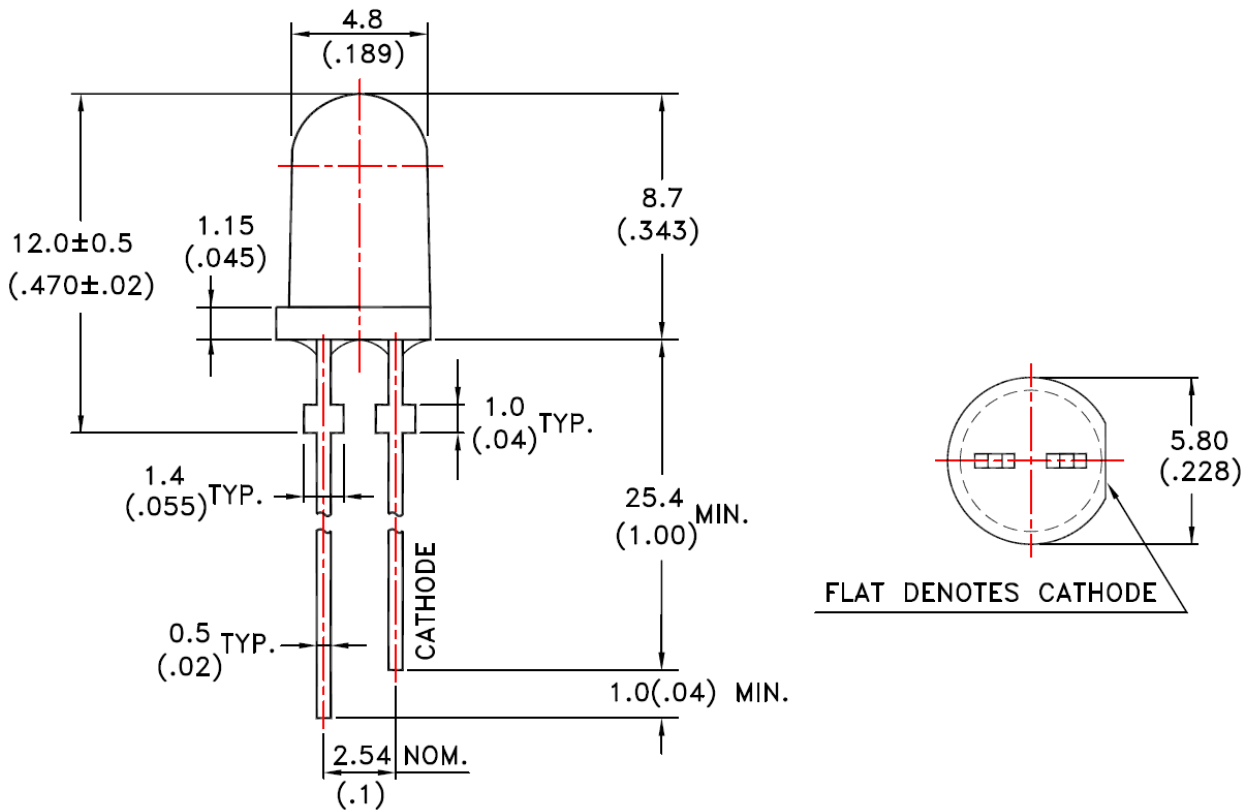

Part No.	Lens	Source Color
LTL2P3TBU2KS	Water clear	InGaN Blue

### Notes:

1. All dimensions are in millimeters (inches).
2. Tolerance is  $\pm 0.25\text{mm} (.010\text{'})$  unless otherwise noted.
3. Lead spacing is measured where the leads emerge from the package.
4. Specifications are subject to change without notice.



# LITE-ON TECHNOLOGY CORPORATION

Property of Lite-On Only

## Absolute Maximum Ratings at TA=25°C

Parameter	Maximum Rating	Unit
Power Dissipation	105	mW
Peak Forward Current (1/10 Duty Cycle, 0.1ms Pulse Width)	100	mA
DC Forward Current	30	mA
Derating Linear From 30°C	0.45	mA/°C
Operating Temperature Range	-30°C to + 85°C	
Storage Temperature Range	-40°C to + 100°C	
Lead Soldering Temperature [2.0 mm(.078") From Body]	260°C for 5 Seconds Max.	

## Electrical / Optical Characteristics at TA=25°C

Parameter	Symbol	Min.	Typ.	Max.	Unit	Test Condition
Luminous Intensity	I <sub>v</sub>	4200		7200	mcd	I <sub>F</sub> = 20mA Note 1,5
Viewing Angle	2θ <sub>1/2</sub>		23		deg	Note 2 (Fig.6)
Peak Emission Wavelength	λ <sub>P</sub>		472		nm	Measurement @Peak (Fig.1)
Dominant Wavelength	λ <sub>d</sub>	464		472	nm	Note 3
Spectral Line Half-Width	Δλ		26		nm	
Forward Voltage	V <sub>F</sub>	2.75		3.5	V	I <sub>F</sub> = 20mA
Reverse Current	I <sub>R</sub>			100	μA	V <sub>R</sub> = 5V, Note 8

NOTE: 1. Luminous intensity is measured with a light sensor and filter combination that approximates the CIE eye-response curve.

2. θ<sub>1/2</sub> is the off-axis angle at which the luminous intensity is half the axial luminous intensity.

3. The dominant wavelength, λ<sub>d</sub> is derived from the CIE chromaticity diagram and represents the single wavelength which defines the color of the device.

4. I<sub>v</sub> classification code is marked on each packing bag.

5. The I<sub>v</sub> guarantee should be added ±15% tolerance.

6. Precautions in handling:

When soldering, leave 2mm of minimum clearance from the resin to the soldering point.

Dipping the resin to solder must be avoided.

Correcting the soldered position after soldering must be avoided.

In soldering, do not apply any stress to the lead frame particularly when heated.

When forming a lead, make sure not to apply any stress inside the resin.

Lead forming must be done before soldering.

It is necessary to cut the lead frame at normal temperature.

7. Caution in ESD:

Static Electricity and surge damages the LED. It is recommend to use a wrist band or anti-electrostatic glove when handling the LED. All devices, equipment and machinery must be properly grounded.

8. Reverse voltage (V<sub>R</sub>) condition is applied for I<sub>R</sub> test only. The device is not designed for reverse operation

**Typical Electrical / Optical Characteristics Curves**

(25°C Ambient Temperature Unless Otherwise Noted)

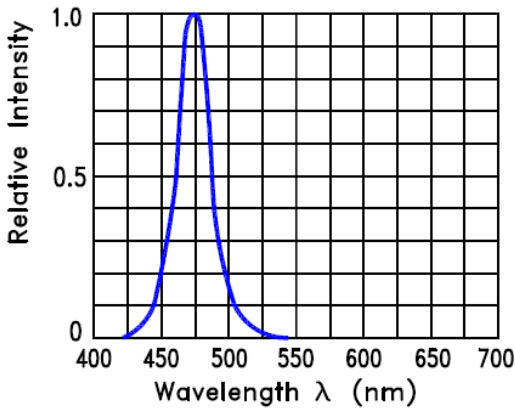

**Fig.1 Relative Intensity VS. Wavelength**

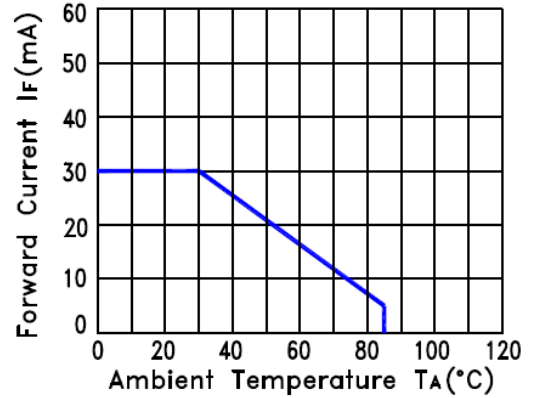

**Fig.2 Forward Current Derating Curve**

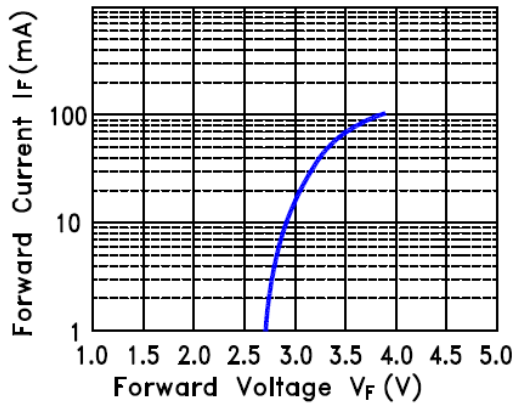

**Fig.3 Forward Current vs. Forward Voltage**

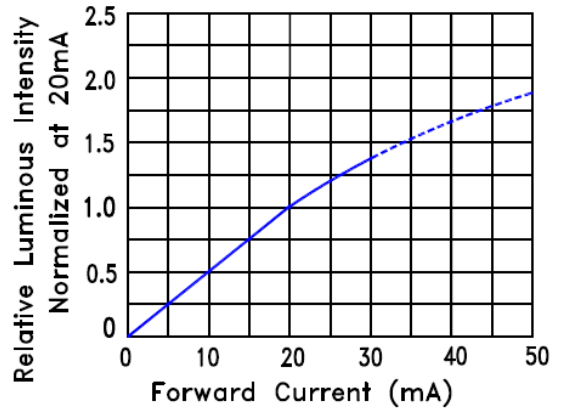

**Fig.4 Relative Luminous Intensity vs. Forward Current**

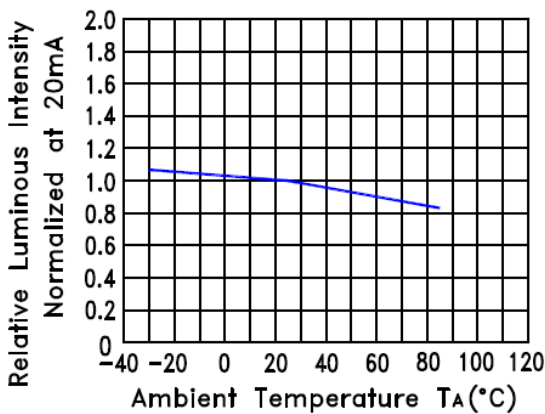

**Fig.5 Relative Luminous Intensity VS. Ambient Temperature**

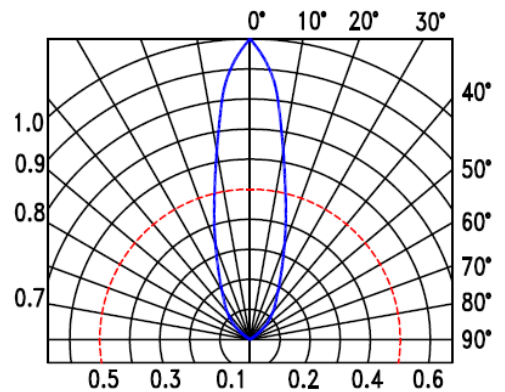

**Fig.6 Spatial Distribution**

**Packing Spec**

**500 or 250 pcs per packing bag**

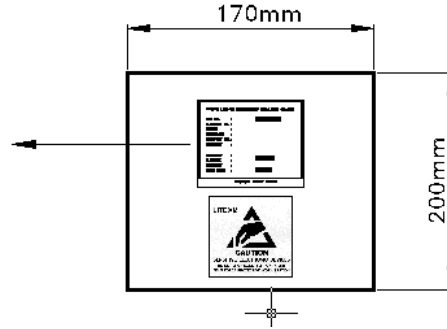
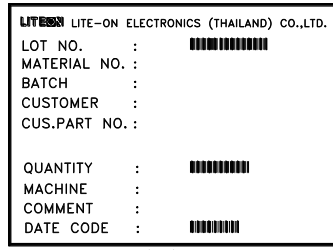

**10 packing bags per inner carton  
total 5000 pcs per inner carton**

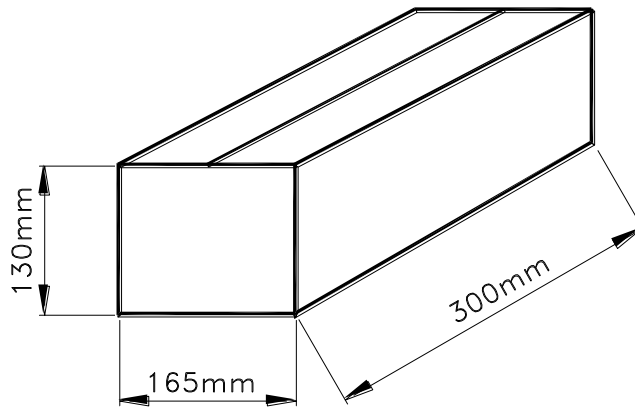

**8 Inner cartons per outer carton  
total 40000 pcs per outer carton  
In every shipping lot, only the last pack will be non-full packing**

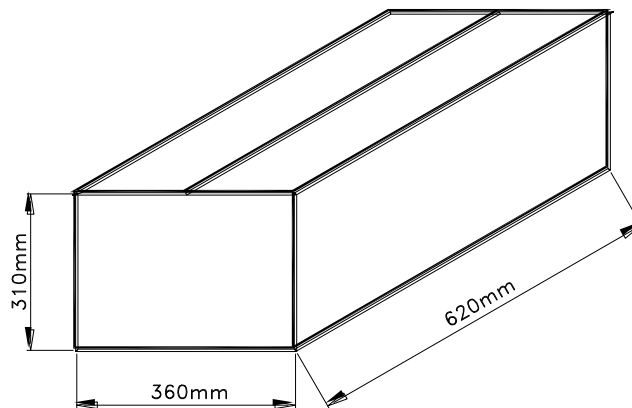



# LITE-ON TECHNOLOGY CORPORATION

Property of Lite-On Only

## Bin Table Specifications

<b>Luminous Intensity</b>		<b>Unit : mcd @20mA</b>
Bin Code	Min.	Max.
U	4200	5500
V	5500	7200

Note: Tolerance of each bin limit is  $\pm 15\%$

<b>Dominant Wavelength</b>		<b>Unit : nm @20mA</b>
Bin Code	Min.	Max.
B01	464	468
B02	468	472

Note: Tolerance of each bin limit is  $\pm 1\text{nm}$

<b>Forward Voltage Vf (Volts)</b>		<b>IF@20mA</b>
Bin Code	Min.	Max.
3	2.75	3.00
4	3.00	3.25
5	3.25	3.50

Note: Tolerance of each bin limit is  $\pm 0.1\text{V}$

## CAUTIONS

### 1. Application

The LEDs described here are intended to be used for ordinary electronic equipment (such as office equipment, communication equipment and household applications). Consult Liteon's Sales in advance for information on applications in which exceptional reliability is required, particularly when the failure or malfunction of the LEDs may directly jeopardize life or health (such as in aviation, transportation, traffic control equipment, medical and life support systems and safety devices).

### 2. Storage

The storage ambient for the LEDs should not exceed 30°C temperature or 70% relative humidity. It is recommended that LEDs out of their original packaging are used within three months. For extended storage out of their original packaging, it is recommended that the LEDs be stored in a sealed container with appropriate desiccant or in desiccators with nitrogen ambient.

### 3. Cleaning

Use alcohol-based cleaning solvents such as isopropyl alcohol to clean the LEDs if necessary.

### 4. Lead Forming & Assembly

During lead forming, the leads should be bent at a point at least 3mm from the base of LED lens.

Do not use the base of the lead frame as a fulcrum during forming.

Lead forming must be done before soldering, at normal temperature.

During assembly on PCB, use minimum clinch force possible to avoid excessive mechanical stress.

### 5. Soldering

When soldering, leave a minimum of 2mm clearance from the base of the lens to the soldering point.

Dipping the lens into the solder must be avoided.

Do not apply any external stress to the lead frame during soldering while the LED is at high temperature.

Recommended soldering conditions :

Soldering iron		Wave soldering	
Temperature	300°C Max.	Pre-heat	100°C Max.
Soldering time	3 sec. Max. (one time only)	Pre-heat time	60 sec. Max.
		Solder wave	260°C Max.
		Soldering time	5 sec. Max.

Note: Excessive soldering temperature and/or time might result in deformation of the LED lens or catastrophic failure of the LED. IR reflow is not suitable process for through hole type LED lamp product.

## 6. Drive Method

An LED is a current-operated device. In order to ensure intensity uniformity on multiple LEDs connected in parallel in an application, it is recommended that a current limiting resistor be incorporated in the drive circuit, in series with each LED as shown in Circuit A below.

**Circuit model A**

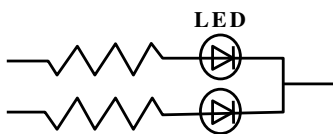

**Circuit model B**

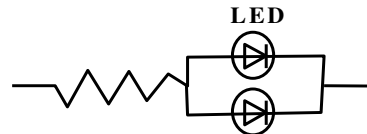

(A) Recommended circuit

(B) The brightness of each LED might appear different due to the differences in the I-V characteristics of those LEDs

## 7. ESD (Electrostatic Discharge)

Static Electricity or power surge will damage the LED.

Suggestions to prevent ESD damage:

- Use a conductive wrist band or anti- electrostatic glove when handling these LEDs
- All devices, equipment, and machinery must be properly grounded
- Work tables, storage racks, etc. should be properly grounded
- Use ion blower to neutralize the static charge which might have built up on surface of the LEDs plastic lens as a result of friction between LEDs during storage and handing



# LITE-ON TECHNOLOGY CORPORATION

Property of Lite-On Only

## Suggested checking list :

### Training and Certification

1. Everyone working in a static-safe area is ESD-certified?
2. Training records kept and re-certification dates monitored?

### Static-Safe Workstation & Work Areas

1. Static-safe workstation or work-areas have ESD signs?
2. All surfaces and objects at all static-safe workstation and within 1 ft measure less than 100V?
3. All ionizer activated, positioned towards the units?
4. Each work surface mats grounding is good?

### Personnel Grounding

1. Every person (including visitors) handling ESD sensitive (ESDS) items wear wrist strap, heel strap or conductive shoes with conductive flooring?
2. If conductive footwear used, conductive flooring also present where operator stand or walk?
3. Garments, hairs or anything closer than 1 ft to ESD items measure less than 100V\*?
4. Every wrist strap or heel strap/conductive shoes checked daily and result recorded for all DLs?
5. All wrist strap or heel strap checkers calibration up to date?

Note: \*50V for Blue LED.

### Device Handling

1. Every ESDS items identified by EIA-471 labels on item or packaging?
2. All ESDS items completely inside properly closed static-shielding containers when not at static-safe workstation?
3. No static charge generators (e.g. plastics) inside shielding containers with ESDS items?
4. All flexible conductive and dissipative package materials inspected before reuse or recycle?

### Others

1. Audit result reported to entity ESD control coordinator?
2. Corrective action from previous audits completed?
3. Are audit records complete and on file?

## 8. Reliability Test

Classification	Test Item	Test Condition	Sample Size	Reference Standard
Endurance Test	Operation Life	Ta = 25°C IF = 30mA *Test Time= 1000hrs	45 PCS (CL=90%; LTPD=5%)	MIL-STD-750D:1026 (1995) MIL-STD-883G:1005 (2006)
	High Temperature/ High Humidity storage (THB)	Ta = 85°C RH = 85% *Test Time= 1000hrs	45 PCS (CL=90%; LTPD=5%)	MIL-STD-202G:103B (2002) JEITA ED-4701:100 103 (2001)
	Steady state Operation Life of High Humidity Heat	Ta = 85°C, RH= 85 % IF = 8 mA *Test Time= 500hrs	76 PCS (CL=90%; LTPD=3%)	JESD22-A101C (2009)
	Low Temperature Operation Life of	Ta = -30°C IF = 30mA *Test Time= 1000hrs	45 PCS (CL=90%; LTPD=5%)	
	High Temperature Storage	Ta= 105 ± 5°C *Test Time= 1000hrs	45 PCS (CL=90%; LTPD=5%)	MIL-STD-750D:1031 (1995) MIL-STD-883G:1008 (2006) JEITA ED-4701:200 201 (2001)
	Low Temperature Storage	Ta= -55 ± 5°C *Test Time= 1000hrs	45 PCS (CL=90%; LTPD=5%)	JEITA ED-4701:200 202 (2001)
Environmental Test	Temperature Cycling	100°C ~ 25°C ~ -40°C ~ 25°C 30mins 5mins 30mins 5mins *Test time: 200 Cycles	76 PCS (CL=90%; LTPD=3%)	MIL-STD-750D:1051 (1995) MIL-STD-883G:1010 (2006) JEITA ED-4701:100 105 (2001) JESD22-A104C (2005)
	Thermal Shock	100 ± 5°C ~ -30°C ± 5°C 15mins 15mins *Test time: 200 Cycles (<20 secs transfer)	76 PCS (CL=90%; LTPD=3%)	MIL-STD-750D:1056 (1995) MIL-STD-883G:1011 (2006) MIL-STD-202G:107G (2002) JESD22-A106B (2004)
	Solder Resistance	T. sol = 260 ± 5°C Dwell Time= 10±1 seconds 3mm from the base of the epoxy bulb	11 PCS (CL=90%; LTPD=18.9%)	MIL-STD-750D:2031(1995) JEITA ED-4701: 300 302 (2001)
	Solderability	T. sol = 245 ± 5°C Dwell Time= 5 ± 0.5 seconds (Lead Free Solder, Coverage ≥ 95% of the dipped surface)	11 PCS (CL=90%; LTPD=18.9%)	MIL-STD-750D:2026 (1995) MIL-STD-883G:2003 (2006) MIL-STD-202G:208H (2002) IPC/EIA J-STD-002 (2004)
	Soldering Iron	T. sol = 350 ± 5°C Dwell Time= 3.5 ± 0.5 seconds	11 PCS (CL=90%; LTPD=18.9%)	MIL-STD-202G:208H (2002) JEITA ED-4701:300 302 (2001)

## 9. Others

The appearance and specifications of the product may be modified for improvement, without prior notice.