



Chipsmall Limited consists of a professional team with an average of over 10 year of expertise in the distribution of electronic components. Based in Hongkong, we have already established firm and mutual-benefit business relationships with customers from,Europe,America and south Asia,supplying obsolete and hard-to-find components to meet their specific needs.

With the principle of "Quality Parts,Customers Priority,Honest Operation,and Considerate Service",our business mainly focus on the distribution of electronic components. Line cards we deal with include Microchip,ALPS,ROHM,Xilinx,Pulse,ON,Everlight and Freescale. Main products comprise IC,Modules,Potentiometer,IC Socket,Relay,Connector.Our parts cover such applications as commercial,industrial, and automotives areas.

We are looking forward to setting up business relationship with you and hope to provide you with the best service and solution. Let us make a better world for our industry!



Contact us

Tel: +86-755-8981 8866 Fax: +86-755-8427 6832

Email & Skype: info@chipsmall.com Web: www.chipsmall.com

Address: A1208, Overseas Decoration Building, #122 Zhenhua RD., Futian, Shenzhen, China



FEATURES

- Complete Switch Mode Power Supply
- Wide Input Voltage Range: 4.5V to 28V
- 10A DC, 12A Peak Output Current
- Parallel Two μ Module™ DC/DC Converters for 20A Output Current
- 0.6V to 5V Output Voltage
- 1.5% Output Voltage Regulation
- Ultrafast Transient Response
- Current Mode Control
- -55°C to 125°C Operating Temperature Range (LTM4600HVMPV)
- RoHS Compliant Package with Gold Pad Finish (e4)
- Up to 92% Efficiency
- Programmable Soft-Start
- Output Overvoltage Protection
- Optional Short-Circuit Shutdown Timer
- Small Footprint, Low Profile (15mm × 15mm × 2.82mm) LGA Package

APPLICATIONS

- Telecom and Networking Equipment
- Military and Avionics Systems
- Industrial Equipment
- Point of Load Regulation
- Servers

DESCRIPTION

The **LTM®4600HV** is a complete 10A, DC/DC step down power supply with up to 28V input operation. Included in the package are the switching controller, power FETs, inductor, and all support components. Operating over an input voltage range of 4.5V to 28V, the LTM4600HV supports an output voltage range of 0.6V to 5V, set by a single resistor. This high efficiency design delivers 10A continuous current (12A peak), needing no heat sinks or airflow to meet power specifications. Only bulk input and output capacitors are needed to finish the design.

The low profile package (2.82mm) enables utilization of unused space on the bottom of PC boards for high density point of load regulation. High switching frequency and an adaptive on-time current mode architecture enables a very fast transient response to line and load changes without sacrificing stability. Fault protection features include integrated overvoltage and short circuit protection with a defeatable shutdown timer. A built-in soft-start timer is adjustable with a small capacitor.

The LTM4600HV is packaged in a compact (15mm × 15mm) and low profile (2.82mm) over-molded Land Grid Array (LGA) package suitable for automated assembly by standard surface mount equipment. The LTM4600HV is RoHS compliant.

LT, LT, LTC, LTM, μ Module and OPTI-LOOP are registered trademarks of Linear Technology Corporation. All other trademarks are the property of their respective owners.

TYPICAL APPLICATION

10A μ Module Power Supply with 4.5V to 28V Input

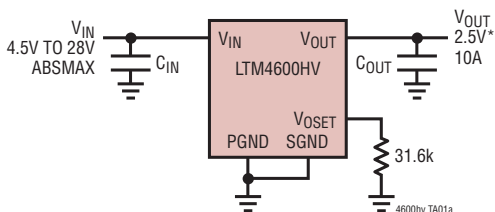

* REVIEW DE-RATING CURVE AT THE HIGHER INPUT VOLTAGE

Efficiency vs Load Current with 24V_{IN} (FCB = 0)

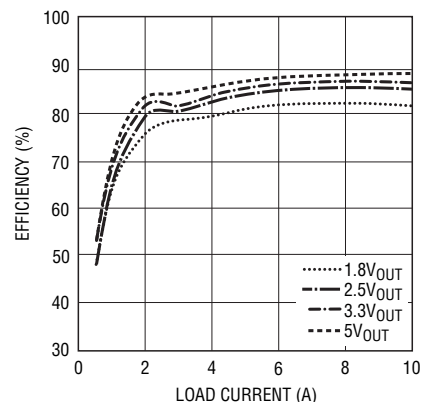

4600hv TA01b

4600hvfe

LTM4600HV

ABSOLUTE MAXIMUM RATINGS

(Note 1)

FCB, EXT V_{CC} , PGOOD, RUN/SS, V_{OUT}	-0.3V to 6V
V_{IN} , SV V_{IN} , f_{ADJ}	-0.3V to 28V
V_{OSET} , COMP	-0.3V to 2.7V
Operating Temperature Range (Note 2)	
E and I Grades	-40°C to 85°C
MP Grade.....	-55°C to 125°C
Junction Temperature	125°C
Storage Temperature Range	-55°C to 125°C
Peak Solder Reflow Body Temperature	245°C

PIN CONFIGURATION

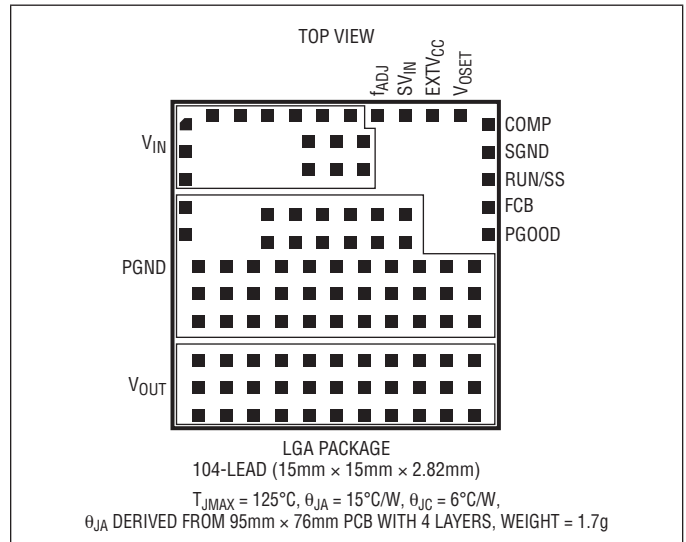

ORDER INFORMATION

PART NUMBER	PAD OR BALL FINISH	PART MARKING		PACKAGE TYPE	MSL RATING	TEMPERATURE RANGE (SEE NOTE 2)
		DEVICE	FINISH CODE			
LTM4600HVEV#PBF	Au (RoHS)	LTM4600HVEV	e4	LGA	3	-40°C to 85°C
LTM4600HVIV#PBF		LTM4600HVIV				-40°C to 85°C
LTM4600HVMPV#PBF		LTM4600HVMPV				-55°C to 125°C

- Consult Marketing for parts specified with wider operating temperature ranges. *Pad or ball finish code is per IPC/JEDEC J-STD-609.
- Terminal Finish Part Marking: www.linear.com/leadfree
- Recommended LGA and BGA PCB Assembly and Manufacturing Procedures: www.linear.com/umodule/pcbassembly
- LGA and BGA Package and Tray Drawings: www.linear.com/packaging

ELECTRICAL CHARACTERISTICS

The ● denotes the specifications which apply over the full operating temperature range, otherwise specifications are at $T_A = 25^\circ\text{C}$, $V_{IN} = 12\text{V}$. External $C_{IN} = 120\mu\text{F}$, $C_{OUT} = 200\mu\text{F}$ /Ceramic per typical application (front page) configuration.

SYMBOL	PARAMETER	CONDITIONS		MIN	TYP	MAX	UNITS
$V_{IN(DC)}$	Input DC Voltage	Abs Max 28V for Tolerance on 24V Inputs	●	4.5		28	V
$V_{OUT(DC)}$	Output Voltage	FCB = 0V $V_{IN} = 5\text{V}$ or 12V , $V_{OUT} = 1.5\text{V}$, $I_{OUT} = 0\text{A}$	●	1.478 1.470	1.50 1.50	1.522 1.530	V V
Input Specifications							
$V_{IN(UVLO)}$	Under Voltage Lockout Threshold	$I_{OUT} = 0\text{A}$			3.4	4	V
$I_{INRUSH(VIN)}$	Input Inrush Current at Startup	$I_{OUT} = 0\text{A}$, $V_{OUT} = 1.5\text{V}$, FCB = 0 $V_{IN} = 5\text{V}$ $V_{IN} = 12\text{V}$ $V_{IN} = 24\text{V}$			0.6 0.7 0.8		A A A
$I_Q(VIN)$	Input Supply Bias Current	$I_{OUT} = 0\text{A}$, EXT V_{CC} Open $V_{IN} = 12\text{V}$, $V_{OUT} = 1.5\text{V}$, FCB = 5V $V_{IN} = 12\text{V}$, $V_{OUT} = 1.5\text{V}$, FCB = 0V $V_{IN} = 24\text{V}$, $V_{OUT} = 2.5\text{V}$, FCB = 5V $V_{IN} = 24\text{V}$, $V_{OUT} = 2.5\text{V}$, FCB = 0V Shutdown, RUN = 0.8V, $V_{IN} = 12\text{V}$			1.2 42 1.8 36 35	75	mA mA mA mA μA
Min On Time					100		ns
Min Off Time					400		ns
$I_S(VIN)$	Input Supply Current	$V_{IN} = 12\text{V}$, $V_{OUT} = 1.5\text{V}$, $I_{OUT} = 10\text{A}$ $V_{IN} = 12\text{V}$, $V_{OUT} = 3.3\text{V}$, $I_{OUT} = 10\text{A}$ $V_{IN} = 5\text{V}$, $V_{OUT} = 1.5\text{V}$, $I_{OUT} = 10\text{A}$ $V_{IN} = 24\text{V}$ to 3.3V at 10A , EXT $V_{CC} = 5\text{V}$			1.52 3.13 3.64 1.6		A A A A
Output Specifications							
I_{OUTDC}	Output Continuous Current Range (See Output Current Derating Curves for Different V_{IN} , V_{OUT} and T_A)	$V_{IN} = 12\text{V}$, $V_{OUT} = 1.5\text{V}$ $V_{IN} = 24\text{V}$, $V_{OUT} = 2.5\text{V}$ (Note 3)		0 0		10 10	A A
$\frac{\Delta V_{OUT(LINE)}}{V_{OUT}}$	Line Regulation Accuracy	$V_{OUT} = 1.5\text{V}$. FCB = 0V, $I_{OUT} = 0\text{A}$, $V_{IN} = 4.5\text{V}$ to 28V	●		0.15	0.3	%
$\frac{\Delta V_{OUT(LOAD)}}{V_{OUT}}$	Load Regulation Accuracy	$V_{OUT} = 1.5\text{V}$. FCB = 0V, $I_{OUT} = 0\text{A}$ to 10A $V_{IN} = 5\text{V}$ $V_{IN} = 12\text{V}$ (Notes 4, 5)	●			± 1 ± 1.5	% %
$V_{OUT(AC)}$	Output Ripple Voltage	$V_{IN} = 12\text{V}$, $V_{OUT} = 1.5\text{V}$, FCB = 0V, $I_{OUT} = 0\text{A}$			10	15	mV _{P-P}
f_s	Output Ripple Voltage Frequency	FCB = 0V, $I_{OUT} = 5\text{A}$, $V_{IN} = 12\text{V}$, $V_{OUT} = 1.5\text{V}$			850		kHz
t_{START}	Turn-On Time	$V_{OUT} = 1.5\text{V}$, $I_{OUT} = 1\text{A}$ $V_{IN} = 12\text{V}$ $V_{IN} = 5\text{V}$			0.5 0.7		ms ms
ΔV_{OUTLS}	Voltage Drop for Dynamic Load Step	$V_{OUT} = 1.5\text{V}$, Load Step: $0\text{A}/\mu\text{s}$ to $5\text{A}/\mu\text{s}$ $C_{OUT} = 3 \times 22\mu\text{F}$ 6.3V, $470\mu\text{F}$ 4V POSCAP, See Table 2			36		mV
t_{SETTLE}	Settling Time for Dynamic Load Step $V_{IN} = 12\text{V}$	Load: 10% to 90% to 10% of Full Load			25		μs
I_{OUTPK}	Output Current Limit	Output Voltage in Foldback $V_{IN} = 24\text{V}$, $V_{OUT} = 2.5\text{V}$ $V_{IN} = 12\text{V}$, $V_{OUT} = 1.5\text{V}$ $V_{IN} = 5\text{V}$, $V_{OUT} = 1.5\text{V}$			17 17 17		A A A
Control Stage							
V_{OSET}	Voltage at V_{OSET} Pin	$I_{OUT} = 0\text{A}$, $V_{OUT} = 1.5\text{V}$	●	0.591 0.594	0.6 0.6	0.609 0.606	V V
$V_{RUN/SS}$	RUN ON/OFF Threshold			0.8	1.5	2	V

ELECTRICAL CHARACTERISTICS

The ● denotes the specifications which apply over the full operating temperature range, otherwise specifications are at $T_A = 25^\circ\text{C}$, $V_{IN} = 12\text{V}$. External $C_{IN} = 120\mu\text{F}$, $C_{OUT} = 200\mu\text{F}$ /Ceramic per typical application (front page) configuration.

SYMBOL	PARAMETER	CONDITIONS	MIN	TYP	MAX	UNITS
$I_{\text{RUN(C)SS}}$	Soft-Start Charging Current	$V_{\text{RUN/SS}} = 0\text{V}$	-0.5	-1.2	-3	μA
$I_{\text{RUN(D)SS}}$	Soft-Start Discharging Current	$V_{\text{RUN/SS}} = 4\text{V}$	0.8	1.8	3	μA
$V_{\text{IN}} - SV_{\text{IN}}$		$\text{EXTV}_{\text{CC}} = 0\text{V}$, $\text{FCB} = 0\text{V}$		100		mV
I_{EXTVCC}	Current into EXTV_{CC} Pin	$\text{EXTV}_{\text{CC}} = 5\text{V}$, $\text{FCB} = 0\text{V}$, $V_{\text{OUT}} = 1.5\text{V}$, $I_{\text{OUT}} = 0\text{A}$		16		mA
R_{FBHI}	Resistor Between V_{OUT} and V_{OSET} Pins			100		$\text{k}\Omega$
V_{FCB}	Forced Continuous Threshold		0.57	0.6	0.63	V
I_{FCB}	Forced Continuous Pin Current	$V_{\text{FCB}} = 0.6\text{V}$		-1	-2	μA

PGOOD Output

ΔV_{OSETH}	PGOOD Upper Threshold	V_{OSET} Rising	7.5	10	12.5	%
ΔV_{OSETL}	PGOOD Lower Threshold	V_{OSET} Falling	-7.5	-10	-12.5	%
$\Delta V_{\text{OSET(HYS)}}$	PGOOD Hysteresis	V_{OSET} Returning		2		%
V_{PGL}	PGOOD Low Voltage	$I_{\text{PGOOD}} = 5\text{mA}$		0.15	0.4	V

Note 1: Stresses beyond those listed under Absolute Maximum Ratings may cause permanent damage to the device. Exposure to any Absolute Maximum Rating condition for extended periods may affect device reliability and lifetime.

Note 2: The LTM4600HVE is guaranteed to meet performance specifications from 0°C to 85°C . Specifications over the -40°C to 85°C operating temperature range are assured by design, characterization and correlation with statistical process controls. The LTM4600HVI

is guaranteed over the -40°C to 85°C temperature range. The LTM46000HVMP is guaranteed and tested over the -55°C to 125°C temperature range.

Note 3: For output current derating at high temperature, please refer to Thermal Considerations and Output Current Derating discussion.

Note 4: Test assumes current derating versus temperature.

Note 5: Guaranteed by correlation.

TYPICAL PERFORMANCE CHARACTERISTICS (See Figure 21 for all curves)

Efficiency vs Load Current with 5V_{IN} (FCB = 0)

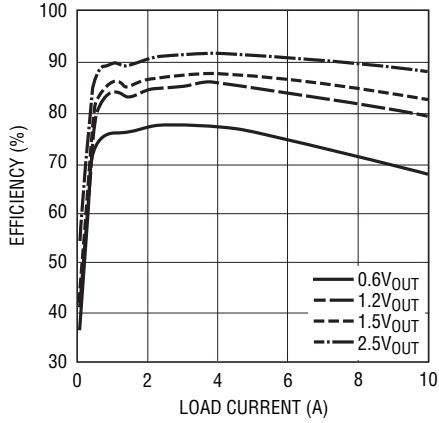

4600hv G01

Efficiency vs Load Current with 12V_{IN} (FCB = 0)

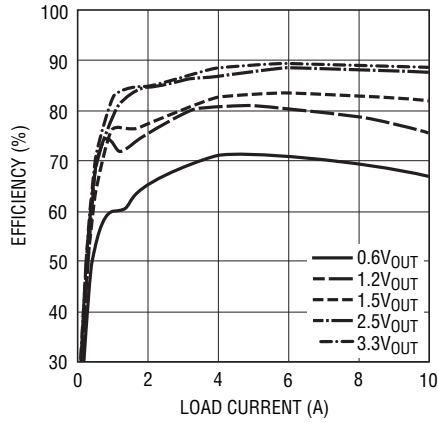

4600hv G02

Efficiency vs Load Current with 24V_{IN} (FCB = 0)

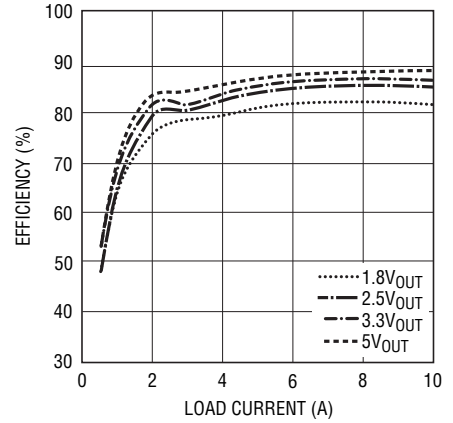

4600hv G03

Efficiency vs Load Current with Different FCB Settings

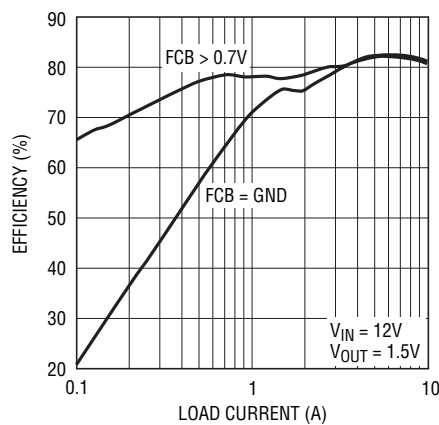

4600hv G04

1.2V Transient Response

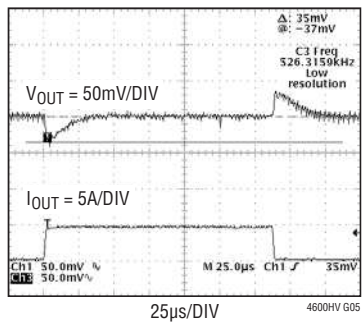

1.2V AT 5A/ μ S LOAD STEP
 $C_{OUT} = 3 \cdot 22\mu F$ 6.3V CERAMICS
 470 μF 4V SANYO POSCAP
 $C3 = 100pF$

1.5V Transient Response

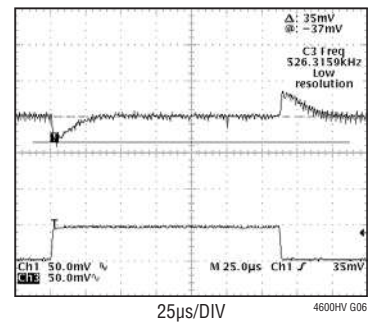

1.5V AT 5A/ μ S LOAD STEP
 $C_{OUT} = 3 \cdot 22\mu F$ 6.3V CERAMICS
 470 μF 4V SANYO POSCAP
 $C3 = 100pF$

1.8V Transient Response

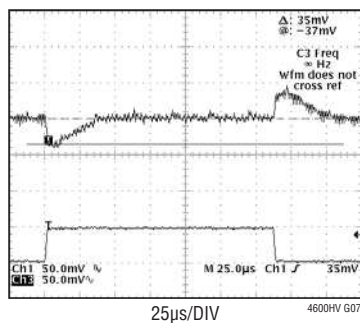

1.8V AT 5A/ μ S LOAD STEP
 $C_{OUT} = 3 \cdot 22\mu F$ 6.3V CERAMICS
 470 μF 4V SANYO POSCAP
 $C3 = 100pF$

2.5V Transient Response

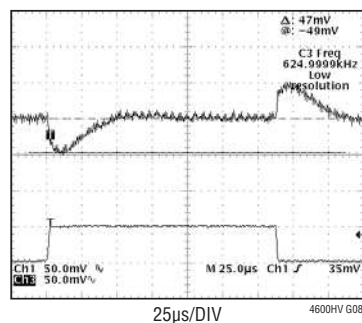

2.5V AT 5A/ μ S LOAD STEP
 $C_{OUT} = 3 \cdot 22\mu F$ 6.3V CERAMICS
 470 μF 4V SANYO POSCAP
 $C3 = 100pF$

3.3V Transient Response

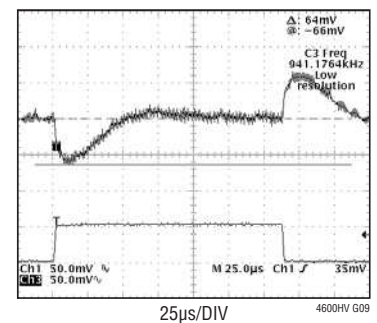

3.3V AT 5A/ μ S LOAD STEP
 $C_{OUT} = 3 \cdot 22\mu F$ 6.3V CERAMICS
 470 μF 4V SANYO POSCAP
 $C3 = 100pF$

TYPICAL PERFORMANCE CHARACTERISTICS (See Figure 21 for all curves)

Start-Up, $I_{OUT} = 0A$

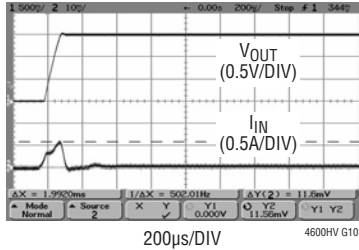

$V_{IN} = 12V$
 $V_{OUT} = 1.5V$
 $C_{OUT} = 200\mu F$
 NO EXTERNAL SOFT-START CAPACITOR

**Start-Up, $I_{OUT} = 10A$
 (Resistive Load)**

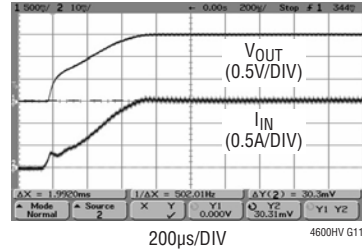

$V_{IN} = 12V$
 $V_{OUT} = 1.5V$
 $C_{OUT} = 200\mu F$
 NO EXTERNAL SOFT-START CAPACITOR

**Short-Circuit Protection,
 $I_{OUT} = 0A$**

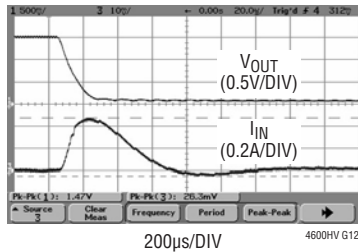

$V_{IN} = 12V$
 $V_{OUT} = 1.5V$
 $C_{OUT} = 2 \times 200\mu F / X5R$
 NO EXTERNAL SOFT-START CAPACITOR

**Short-Circuit Protection,
 $I_{OUT} = 10A$**

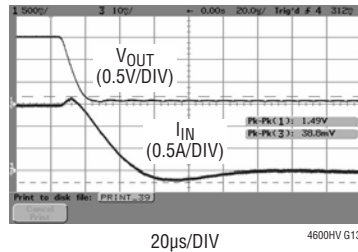

$V_{IN} = 12V$
 $V_{OUT} = 1.5V$
 $C_{OUT} = 2 \times 200\mu F / X5R$
 NO EXTERNAL SOFT-START CAPACITOR

V_{IN} to V_{OUT} Step-Down Ratio

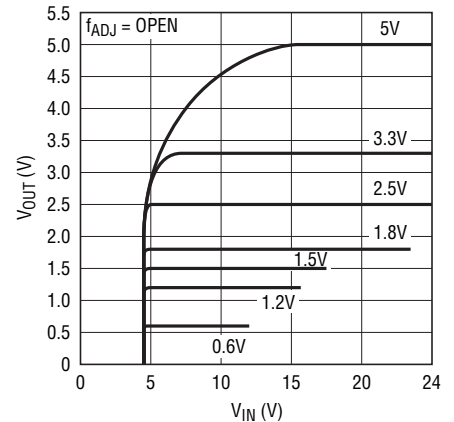

SEE FREQUENCY ADJUSTMENT DISCUSSION FOR 12V_{IN} TO 5V_{OUT} AND 5V_{IN} TO 3.3V_{OUT} CONVERSION

4600HV G14

V_{OSET} vs Temperature

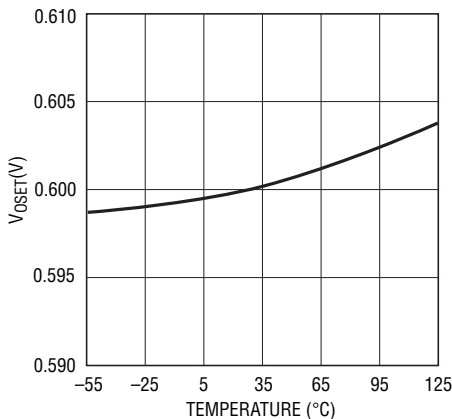

4600HV G15

Start-Up Waveform, $T_A = -55^\circ C$

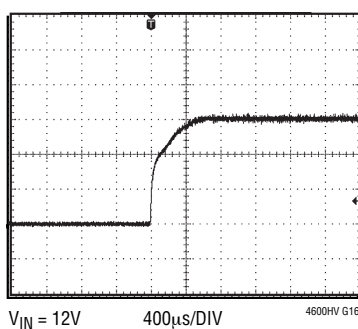

$V_{IN} = 12V$
 $V_{OUT} = 1.5V$
 $I_{OUT} = 10A$

4600HV G16

12V Input Load Regulation vs Temperature

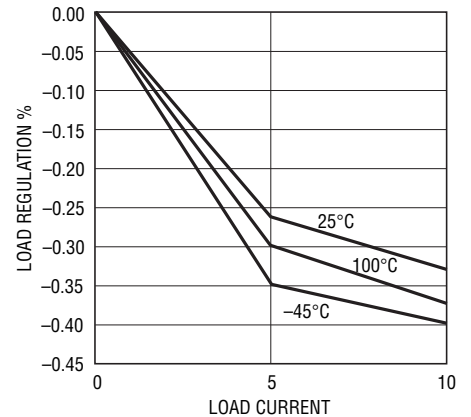

4600HV G17

PIN FUNCTIONS (See Package Description for Pin Assignment)

V_{IN} (Bank 1): Power Input Pins. Apply input voltage between these pins and GND pins. Recommend placing input decoupling capacitance directly between V_{IN} pins and GND pins.

f_{ADJ} (Pin A15): A 110k resistor from V_{IN} to this pin sets the one-shot timer current, thereby setting the switching frequency. The LTM4600HV switching frequency is typically 850kHz. An external resistor to ground can be selected to reduce the one-shot timer current, thus lower the switching frequency to accommodate a higher duty cycle step down requirement. See the applications section.

SV_{IN} (Pin A17): Supply Pin for Internal PWM Controller. Leave this pin open or add additional decoupling capacitance.

$EXTV_{CC}$ (Pin A19): External 5V supply pin for controller. If left open or grounded, the internal 5V linear regulator will power the controller and MOSFET drivers. For high input voltage applications, connecting this pin to an external 5V will reduce the power loss in the power module. The $EXTV_{CC}$ voltage should never be higher than V_{IN} .

V_{OSET} (Pin A21): The Negative Input of The Error Amplifier. Internally, this pin is connected to V_{OUT} with a 100k precision resistor. Different output voltages can be programmed with additional resistors between the V_{OSET} and SGND pins.

COMP (Pin B23): Current Control Threshold and Error Amplifier Compensation Point. The current comparator threshold increases with this control voltage. The voltage ranges from 0V to 2.4V with 0.8V corresponding to zero sense voltage (zero current).

SGND (Pin D23): Signal Ground Pin. All small-signal components should connect to this ground, which in turn connects to PGND at one point.

RUN/SS (Pin F23): Run and Soft-Start Control. Forcing this pin below 0.8V will shut down the power supply. Inside the power module, there is a 1000pF capacitor which provides approximately 0.7ms soft-start time with 200 μ F output capacitance. Additional soft-start time can be achieved by adding additional capacitance between the RUN/SS and SGND pins. The internal short-circuit lathoff can be disabled by adding a resistor between this pin and the V_{IN} pin. This resistor must supply a minimum 5 μ A pull up current. The RUN/SS pin has an internal 6V Zener to ground.

FCB (Pin G23): Forced Continuous Input. Grounding this pin enables forced continuous mode operation regardless of load conditions. Tying this pin above 0.63V enables discontinuous conduction mode to achieve high efficiency operation at light loads. There is an internal 4.75K resistor between the FCB and SGND pins.

PGOOD (Pin J23): Output Voltage Power Good Indicator. When the output voltage is within 10% of the nominal voltage, the PGOOD is open drain output. Otherwise, this pin is pulled to ground.

PGND (Bank 2): Power ground pins for both input and output returns.

V_{OUT} (Bank 3): Power Output Pins. Apply output load between these pins and GND pins. Recommend placing High Frequency output decoupling capacitance directly between these pins and GND pins.

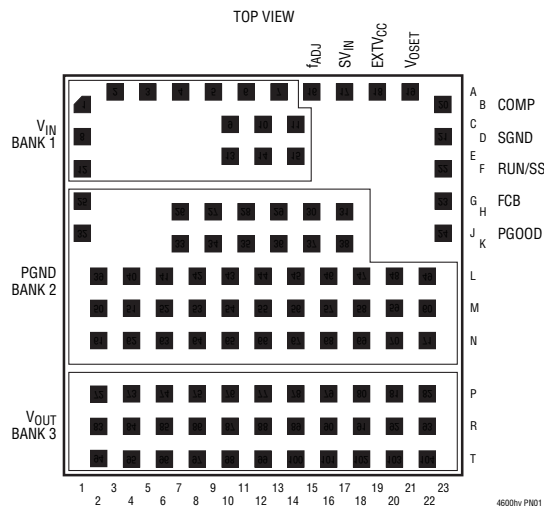

4600hvfe

SIMPLIFIED BLOCK DIAGRAM

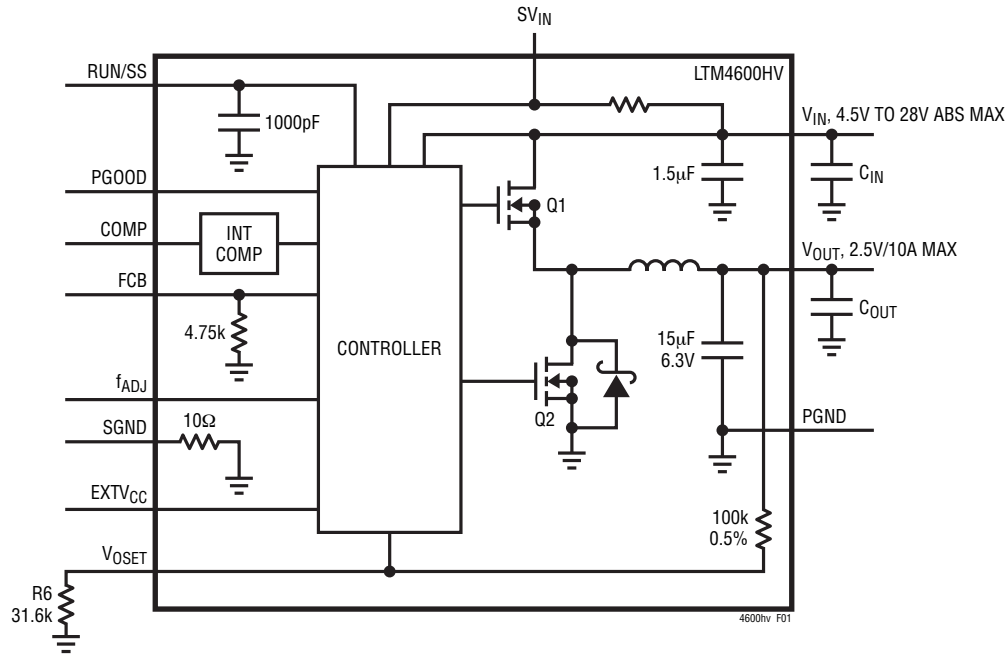

Figure 1. Simplified LTM4600HV Block Diagram

DECOUPLING REQUIREMENTS $T_A = 25^\circ\text{C}$, $V_{IN} = 12\text{V}$. Use Figure 1 configuration.

SYMBOL	PARAMETER	CONDITIONS	MIN	TYP	MAX	UNITS
C_{IN}	External Input Capacitor Requirement ($V_{IN} = 4.5\text{V to } 28\text{V}$, $V_{OUT} = 2.5\text{V}$)	$I_{OUT} = 10\text{A}$, 2x 10μF 35V Ceramic Taiyo Yuden GDK316BJ106ML	20			μF
C_{OUT}	External Output Capacitor Requirement ($V_{IN} = 4.5\text{V to } 28\text{V}$, $V_{OUT} = 2.5\text{V}$)	$I_{OUT} = 10\text{A}$, Refer to Table 2 in the Applications Information Section	100	200		μF

OPERATION

μModule Description

The LTM4600HV is a standalone non-isolated synchronous switching DC/DC power supply. It can deliver up to 10A of DC output current with only bulk external input and output capacitors. This module provides a precisely regulated output voltage programmable via one external resistor from $0.6V_{DC}$ to $5.0V_{DC}$. The input voltage range is 4.5V to 28V. A simplified block diagram is shown in Figure 1 and the typical application schematic is shown in Figure 21.

The LTM4600HV contains an integrated LTC constant on-time current-mode regulator, ultra-low $R_{DS(ON)}$ FETs with fast switching speed and integrated Schottky diode. The typical switching frequency is 850kHz at full load. With current mode control and internal feedback loop compensation, the LTM4600HV module has sufficient stability margins and good transient performance under a wide range of operating conditions and with a wide range of output capacitors, even all ceramic output capacitors (X5R or X7R for extended temperature range).

Current mode control provides cycle-by-cycle fast current limit. In addition, foldback current limiting is provided in an over-current condition while V_{OSET} drops. Also, the LTM4600HV has defeatable short circuit latch off. Internal overvoltage and undervoltage comparators pull the open-drain PGOOD output low if the output feedback voltage exits a $\pm 10\%$ window around the regulation point. Furthermore, in an overvoltage condition, internal top FET

Q1 is turned off and bottom FET Q2 is turned on and held on until the overvoltage condition clears.

Pulling the RUN/SS pin low forces the controller into its shutdown state, turning off both Q1 and Q2. Releasing the pin allows an internal $1.2\mu A$ current source to charge up the soft-start capacitor. When this voltage reaches 1.5V, the controller turns on and begins switching.

At low load current the module works in continuous current mode by default to achieve minimum output voltage ripple. It can be programmed to operate in discontinuous current mode for improved light load efficiency when the FCB pin is pulled up above 0.8V and no higher than 6V. The FCB pin has a 4.75k resistor to ground, so a resistor to V_{IN} can set the voltage on the FCB pin.

When $EXTV_{CC}$ pin is grounded or open, an integrated 5V linear regulator powers the controller and MOSFET gate drivers. If a minimum 4.7V external bias supply is applied on the $EXTV_{CC}$ pin, the internal regulator is turned off, and an internal switch connects $EXTV_{CC}$ to the gate driver voltage. This eliminates the linear regulator power loss with high input voltage, reducing the thermal stress on the controller. The maximum voltage on $EXTV_{CC}$ pin is 6V. The $EXTV_{CC}$ voltage should never be higher than the V_{IN} voltage. Also $EXTV_{CC}$ must be sequenced after V_{IN} . Recommended for 24V operation to lower temperature in the μModule.

APPLICATIONS INFORMATION

The typical LTM4600HV application circuit is shown in Figure 21. External component selection is primarily determined by the maximum load current and output voltage.

Output Voltage Programming and Margining

The PWM controller of the LTM4600HV has an internal $0.6V \pm 1\%$ reference voltage. As shown in the block diagram, a $100k/0.5\%$ internal feedback resistor connects V_{OUT} and V_{OSET} pins. Adding a resistor R_{SET} from V_{OSET} pin to SGND pin programs the output voltage:

$$V_O = 0.6V \cdot \frac{100k + R_{SET}}{R_{SET}}$$

Table 1 shows the standard values of 1% R_{SET} resistor for typical output voltages:

Table 1.

R_{SET} (k Ω)	Open	100	66.5	49.9	43.2	31.6	22.1	13.7
V_O (V)	0.6	1.2	1.5	1.8	2	2.5	3.3	5

Voltage margining is the dynamic adjustment of the output voltage to its worst case operating range in production testing to stress the load circuitry, verify control/protection functionality of the board and improve the system reliability. Figure 2 shows how to implement margining function with the LTM4600HV. In addition to the feedback resistor R_{SET} , several external components are added. Turn off both transistor Q_{UP} and Q_{DOWN} to disable the margining. When Q_{UP} is on and Q_{DOWN} is off, the output voltage is margined up. The output voltage is margined

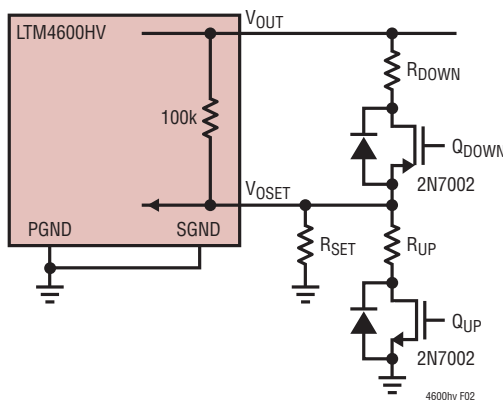

Figure 2. LTM4600HV Margining Implementation

down when Q_{DOWN} is on and Q_{UP} is off. If the output voltage V_O needs to be margined up/down by $\pm M\%$, the resistor values of R_{UP} and R_{DOWN} can be calculated from the following equations:

$$\frac{(R_{SET} || R_{UP}) \cdot V_O \cdot (1 + M\%)}{(R_{SET} || R_{UP}) + 100k\Omega} = 0.6V$$

$$\frac{R_{SET} \cdot V_O \cdot (1 - M\%)}{R_{SET} + (100k\Omega || R_{DOWN})} = 0.6V$$

Input Capacitors

The LTM4600HV μ Module should be connected to a low ac-impedance DC source. High frequency, low ESR input capacitors are required to be placed adjacent to the module. In Figure 21, the bulk input capacitor C_{IN} is selected for its ability to handle the large RMS current into the converter. For a buck converter, the switching duty-cycle can be estimated as:

$$D = \frac{V_O}{V_{IN}}$$

Without considering the inductor current ripple, the RMS current of the input capacitor can be estimated as:

$$I_{CIN(RMS)} = \frac{I_{O(MAX)}}{\eta\%} \cdot \sqrt{D \cdot (1 - D)}$$

In the above equation, $\eta\%$ is the estimated efficiency of the power module. C_1 can be a switcher-rated electrolytic aluminum capacitor, OS-CON capacitor or high volume ceramic capacitors. Note the capacitor ripple current ratings are often based on only 2000 hours of life. This makes it advisable to properly derate the input capacitor, or choose a capacitor rated at a higher temperature than required. Always contact the capacitor manufacturer for derating requirements over temperature.

In Figure 21, the input capacitors are used as high frequency input decoupling capacitors. In a typical 10A output application, 1-2 pieces of very low ESR X5R or X7R (for extended temperature range), $10\mu F$ ceramic capacitors are recommended. This decoupling capacitor should be placed directly adjacent the module input pins

APPLICATIONS INFORMATION

in the PCB layout to minimize the trace inductance and high frequency AC noise.

Output Capacitors

The LTM4600HV is designed for low output voltage ripple. The bulk output capacitors C_{OUT} is chosen with low enough effective series resistance (ESR) to meet the output voltage ripple and transient requirements. C_{OUT} can be low ESR tantalum capacitor, low ESR polymer capacitor or ceramic capacitor (X5R or X7R). The typical capacitance is 200 μ F if all ceramic output capacitors are used. The internally optimized loop compensation provides sufficient stability margin for all ceramic capacitors applications. Additional output filtering may be required by the system designer, if further reduction of output ripple or dynamic transient spike is required. Refer to Table 2 for an output capacitance matrix for each output voltage droop, peak to peak deviation and recovery time during a 5A/ μ s transient with a specific output capacitance.

Fault Conditions: Current Limit and Over current Foldback

The LTM4600HV has a current mode controller, which inherently limits the cycle-by-cycle inductor current not only in steady state operation, but also in transient.

To further limit current in the event of an over load condition, the LTM4600HV provides foldback current limiting. If the output voltage falls by more than 50%, then the maximum output current is progressively lowered to about one sixth of its full current limit value.

V_{IN} to V_{OUT} Step-Down Ratios

There are restrictions in the maximum V_{IN} to V_{OUT} step down ratio that can be achieved for a given input voltage. These constraints are shown in V_{IN} to V_{OUT} Step-Down Ratio in the Typical Performance Characteristics section. Note that additional thermal derating may apply. See the Thermal Considerations and Output Current Derating sections of this data sheet.

Soft-Start and Latchoff with the RUN/SS pin

The RUN/SS pin provides a means to shut down the LTM4600HV as well as a timer for soft-start and over-current latchoff. Pulling the RUN/SS pin below 0.8V puts the LTM4600HV into a low quiescent current shutdown ($I_Q \leq 75\mu$ A). Releasing the pin allows an internal 1.2 μ A current source to charge up the timing capacitor C_{SS} . Inside LTM4600HV, there is an internal 1000pF capacitor from RUN/SS pin to ground. If RUN/SS pin has an external capacitor C_{SS_EXT} to ground, the delay before starting is about:

$$t_{DELAY} = \frac{1.5V}{1.2\mu A} \cdot (C_{SS_EXT} + 1000pF)$$

When the voltage on RUN/SS pin reaches 1.5V, the LTM4600HV internal switches are operating with a clamping of the maximum output inductor current limited by the RUN/SS pin total soft-start capacitance. As the RUN/SS pin voltage rises to 3V, the soft-start clamping of the inductor current is released.

APPLICATIONS INFORMATION

Table 2. Output Voltage Response Versus Component Matrix *(Refer to Figure 21)

TYPICAL MEASURED VALUES

C _{OUT1} VENDORS	PART NUMBER	C _{OUT2} VENDORS	PART NUMBER
TDK	C4532X5R0J107MZ (100μF, 6.3V)	SANYO POSCAP	6TPE330MIL (330μF, 6.3V)
TAIYO YUDEN	JMK432BJ107MU-T (100μF, 6.3V)	SANYO POSCAP	2R5TPE470M9 (470μF, 2.5V)
TAIYO YUDEN	JMK316BJ226ML-T501 (22μF, 6.3V)	SANYO POSCAP	4TPE470MCL (470μF, 4V)
TAIYO YUDEN	JMK316BJ226ML-T501 (22μF, 6.3V)	SANYO POSCAP	6TPD470M (470μF, 6.3V)

V _{OUT} (V)	C _{IN} (CERAMIC)	C _{IN} (BULK)	C _{OUT1} (CERAMIC)	C _{OUT2} (BULK)	C _{COMP}	C3	V _{IN} (V)	DROOP (mV)	PEAK TO PEAK (mV)	RECOVERY TIME (μs)	LOAD STEP (A/μs)
1.2	2 × 10μF 35V	150μF 35V	3 × 22μF 6.3V	470μF 4V	NONE	100pF	5	35	68	25	5
1.2	2 × 10μF 35V	150μF 35V	1 × 100μF 6.3V	470μF 2.5V	NONE	100pF	5	35	70	20	5
1.2	2 × 10μF 35V	150μF 35V	2 × 100μF 6.3V	330μF 6.3V	NONE	100pF	5	40	80	20	5
1.2	2 × 10μF 35V	150μF 35V	4 × 100μF 6.3V	NONE	NONE	100pF	5	49	98	20	5
1.2	2 × 10μF 35V	150μF 35V	3 × 22μF 6.3V	470μF 4V	NONE	100pF	12	35	68	25	5
1.2	2 × 10μF 35V	150μF 35V	1 × 100μF 6.3V	470μF 2.5V	NONE	100pF	12	35	70	20	5
1.2	2 × 10μF 35V	150μF 35V	2 × 100μF 6.3V	330μF 6.3V	NONE	100pF	12	40	80	20	5
1.2	2 × 10μF 35V	150μF 35V	4 × 100μF 6.3V	NONE	NONE	100pF	12	49	98	20	5
1.5	2 × 10μF 35V	150μF 35V	3 × 22μF 6.3V	470μF 4V	NONE	100pF	5	36	75	25	5
1.5	2 × 10μF 35V	150μF 35V	1 × 100μF 6.3V	470μF 2.5V	NONE	100pF	5	37	79	20	5
1.5	2 × 10μF 35V	150μF 35V	2 × 100μF 6.3V	330μF 6.3V	NONE	100pF	5	44	84	20	5
1.5	2 × 10μF 35V	150μF 35V	4 × 100μF 6.3V	NONE	NONE	100pF	5	61	118	20	5
1.5	2 × 10μF 35V	150μF 35V	3 × 22μF 6.3V	470μF 4V	NONE	100pF	12	36	75	25	5
1.5	2 × 10μF 35V	150μF 35V	1 × 100μF 6.3V	470μF 2.5V	NONE	100pF	12	37	79	20	5
1.5	2 × 10μF 35V	150μF 35V	2 × 100μF 6.3V	330μF 6.3V	NONE	100pF	12	44	89	20	5
1.5	2 × 10μF 35V	150μF 35V	4 × 100μF 6.3V	NONE	NONE	100pF	12	54	108	20	5
1.8	2 × 10μF 35V	150μF 35V	3 × 22μF 6.3V	470μF 4V	NONE	100pF	5	40	81	30	5
1.8	2 × 10μF 35V	150μF 35V	1 × 100μF 6.3V	470μF 2.5V	NONE	100pF	5	44	88	20	5
1.8	2 × 10μF 35V	150μF 35V	2 × 100μF 6.3V	330μF 6.3V	NONE	100pF	5	46	91	20	5
1.8	2 × 10μF 35V	150μF 35V	4 × 100μF 6.3V	NONE	NONE	100pF	5	62	128	20	5
1.8	2 × 10μF 35V	150μF 35V	3 × 22μF 6.3V	470μF 4V	NONE	100pF	12	40	81	30	5
1.8	2 × 10μF 35V	150μF 35V	1 × 100μF 6.3V	470μF 2.5V	NONE	100pF	12	44	85	20	5
1.8	2 × 10μF 35V	150μF 35V	2 × 100μF 6.3V	330μF 6.3V	NONE	100pF	12	44	91	20	5
1.8	2 × 10μF 35V	150μF 35V	4 × 100μF 6.3V	NONE	NONE	100pF	12	62	125	20	5
2.5	2 × 10μF 35V	150μF 35V	1 × 100μF 6.3V	470μF 4V	NONE	100pF	5	48	103	30	5
2.5	2 × 10μF 35V	150μF 35V	2 × 100μF 6.3V	330μF 6.3V	NONE	100pF	5	56	113	30	5
2.5	2 × 10μF 35V	150μF 35V	3 × 22μF 6.3V	470μF 4V	NONE	100pF	5	57	116	30	5
2.5	2 × 10μF 35V	150μF 35V	4 × 100μF 6.3V	NONE	NONE	100pF	5	60	115	25	5
2.5	2 × 10μF 35V	150μF 35V	1 × 100μF 6.3V	470μF 4V	NONE	100pF	12	48	103	30	5
2.5	2 × 10μF 35V	150μF 35V	3 × 22μF 6.3V	470μF 4V	NONE	100pF	12	51	102	30	5
2.5	2 × 10μF 35V	150μF 35V	2 × 100μF 6.3V	330μF 6.3V	NONE	100pF	12	56	113	30	5
2.5	2 × 10μF 35V	150μF 35V	4 × 100μF 6.3V	NONE	NONE	100pF	12	70	159	25	5
2.5	2 × 10μF 35V	150μF 35V	3 × 22μF 6.3V	470μF 6.3V	NONE	100pF	24	56	112	30	5
2.8	2 × 10μF 35V	150μF 35V	3 × 22μF 6.3V	470μF 6.3V	NONE	100pF	24	50	100	30	5
3.3	2 × 10μF 35V	150μF 35V	2 × 100μF 6.3V	330μF 6.3V	NONE	100pF	7	64	126	30	5
3.3	2 × 10μF 35V	150μF 35V	1 × 100μF 6.3V	470μF 4V	NONE	100pF	7	66	132	30	5
3.3	2 × 10μF 35V	150μF 35V	3 × 22μF 6.3V	470μF 4V	NONE	100pF	7	82	166	35	5
3.3	2 × 10μF 35V	150μF 35V	4 × 100μF 6.3V	NONE	NONE	100pF	7	100	200	25	5
3.3	2 × 10μF 35V	150μF 35V	1 × 100μF 6.3V	470μF 4V	NONE	100pF	12	52	106	30	5
3.3	2 × 10μF 35V	150μF 35V	3 × 22μF 6.3V	470μF 4V	NONE	100pF	12	64	129	35	5
3.3	2 × 10μF 35V	150μF 35V	2 × 100μF 6.3V	330μF 6.3V	NONE	100pF	12	64	126	30	5
3.3	2 × 10μF 35V	150μF 35V	4 × 100μF 6.3V	NONE	NONE	100pF	12	76	144	25	5
3.3	2 × 10μF 35V	150μF 35V	3 × 22μF 6.3V	470μF 6.3V	NONE	100pF	24	74	149	30	5
5	2 × 10μF 35V	150μF 35V	4 × 100μF 6.3V	NONE	NONE	100pF	15	188	375	25	5
5	2 × 10μF 35V	150μF 35V	4 × 100μF 6.3V	NONE	NONE	100pF	20	159	320	25	5

*X7R is recommended for extended temperature range.

APPLICATIONS INFORMATION

After the controller has been started and given adequate time to charge up the output capacitor, C_{SS} is used as a short-circuit timer. After the RUN/SS pin charges above 4V, if the output voltage falls below 75% of its regulated value, then a short-circuit fault is assumed. A $1.8\mu\text{A}$ current then begins discharging C_{SS} . If the fault condition persists until the RUN/SS pin drops to 3.5V, then the controller turns off both power MOSFETs, shutting down the converter permanently. The RUN/SS pin must be actively pulled down to ground in order to restart operation.

The over-current protection timer requires the soft-start timing capacitor C_{SS} be made large enough to guarantee that the output is in regulation by the time C_{SS} has reached the 4V threshold. In general, this will depend upon the size of the output capacitance, output voltage and load current characteristic. A minimum external soft-start capacitor can be estimated from:

$$C_{SS_EXT} + 1000\text{pF} > \frac{C_{OUT} \cdot V_{OUT}}{10\text{kV}}$$

Generally $0.1\mu\text{F}$ is more than sufficient.

Since the load current is already limited by the current mode control and current foldback circuitry during a short-circuit, over-current latchoff operation is NOT always needed or desired, especially the output has large amount of capacitance or the load draw huge current during start up. The latchoff feature can be overridden by a pull-up current greater than $5\mu\text{A}$ but less than $80\mu\text{A}$ to the RUN/SS pin. The additional current prevents the discharge of C_{SS} during a fault and also shortens the soft-start period. Using a resistor from RUN/SS pin to V_{IN} is a simple solution to defeat latchoff. Any pull-up network must be able to maintain RUN/SS above 4V maximum latchoff threshold and overcome the $4\mu\text{A}$ maximum discharge current. With a pull-up resistor, the delay before starting is approximately:

$$t_{DELAY} = -R_{RUN/SS} \cdot (C_{SS_EXT} + 1000\text{pF}) \cdot \ln\left(1 - \frac{1.5\text{V}}{V_{IN} + (1.2\mu\text{A} \cdot R_{RUN/SS})}\right)$$

Figure 3 shows a conceptual drawing of V_{RUN} during startup and short-circuit.

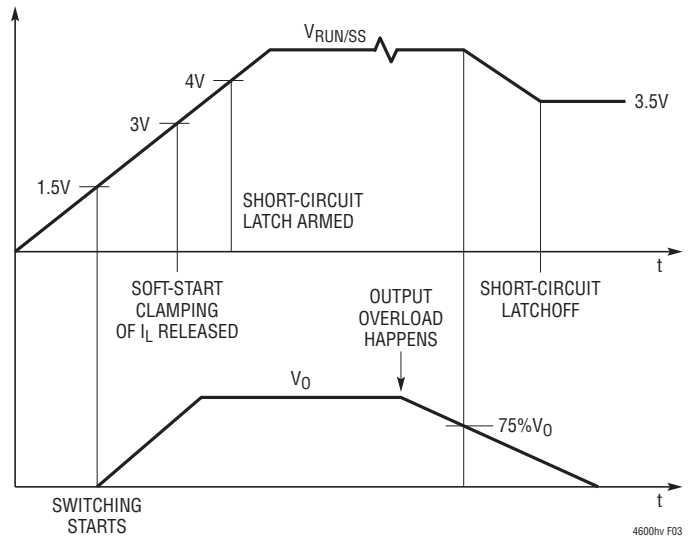

Figure 3. RUN/SS Pin Voltage During Startup and Short-Circuit Protection

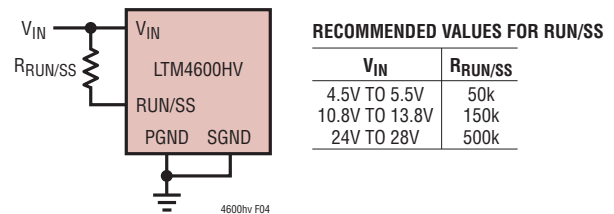

Figure 4. Defeat Short-Circuit Latchoff with a Pull-Up Resistor to V_{IN}

APPLICATIONS INFORMATION

Enable

The RUN/SS pin can be driven from logic as shown in Figure 5. This function allows the LTM4600HV to be turned on or off remotely. The ON signal can also control the sequence of the output voltage.

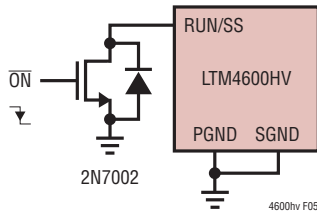

Figure 5. Enable Circuit with External Logic

Output Voltage Tracking

For the applications that require output voltage tracking, several LTM4600HV modules can be programmed by the power supply tracking controller such as the LTC2923. Figure 6 shows a typical schematic with LTC2923. Coincident, ratiometric and offset tracking for V_O rising and falling can be implemented with different sets of resistor values. See the LTC2923 data sheet for more details.

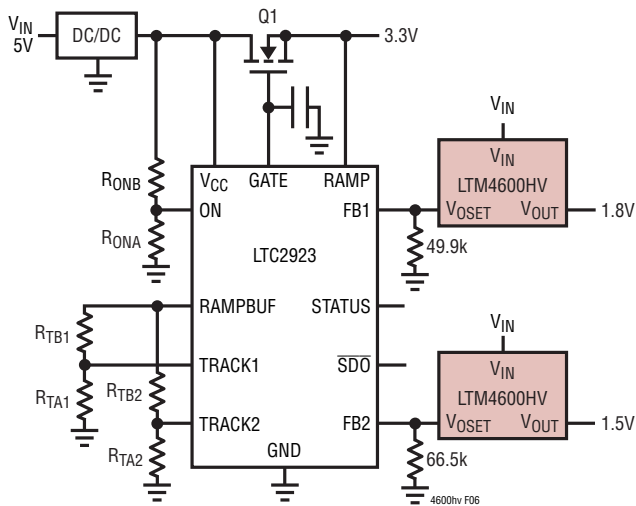

Figure 6. Output Voltage Tracking with the LTC2923 Controller

EXTV_{CC} Connection

An internal low dropout regulator produces an internal 5V supply that powers the control circuitry and FET drivers. Therefore, if the system does not have a 5V power rail, the LTM4600HV can be directly powered by V_{IN} . The gate driver current through LDO is about 18mA. The internal LDO power dissipation can be calculated as:

$$P_{LDO_LOSS} = 18\text{mA} \cdot (V_{IN} - 5\text{V})$$

The LTM4600HV also provides an external gate driver voltage pin EXTV_{CC}. If there is a 5V rail in the system, it is recommended to connect EXTV_{CC} pin to the external 5V rail. Whenever the EXTV_{CC} pin is above 4.7V, the internal 5V LDO is shut off and an internal 50mA P-channel switch connects the EXTV_{CC} to internal 5V. Internal 5V is supplied from EXTV_{CC} until this pin drops below 4.5V. Do not apply more than 6V to the EXTV_{CC} pin and ensure that $EXTV_{CC} < V_{IN}$. The following list summarizes the possible connections for EXTV_{CC}:

1. EXTV_{CC} grounded. Internal 5V LDO is always powered from the internal 5V regulator.
2. EXTV_{CC} connected to an external supply. Internal LDO is shut off. A high efficiency supply compatible with the MOSFET gate drive requirements (typically 5V) can improve overall efficiency. With this connection, it is always required that the EXTV_{CC} voltage can not be higher than V_{IN} pin voltage.
3. EXTV_{CC} is recommended for $V_{IN} > 20\text{V}$

Discontinuous Operation and FCB Pin

The FCB pin determines whether the internal bottom MOSFET remains on when the current reverses. There is an internal 4.75k pull-down resistor connecting this pin to ground. The default light load operation mode is forced continuous (PWM) current mode. This mode provides minimum output voltage ripple.

APPLICATIONS INFORMATION

In the application where the light load efficiency is important, tying the FCB pin above 0.6V threshold enables discontinuous operation where the bottom MOSFET turns off when inductor current reverses. Therefore, the conduction loss is minimized and light load efficiency is improved. The penalty is that the controller may skip cycle and the output voltage ripple increases at light load.

Paralleling Operation with Load Sharing

Two or more LTM4600HV modules can be paralleled to provide higher than 10A output current. Figure 7 shows the necessary interconnection between two paralleled modules. The OPTI-LOOP™ current mode control ensures good current sharing among modules to balance the thermal stress. The new feedback equation for two or more LTM4600HVs in parallel is:

$$V_{OUT} = 0.6V \cdot \frac{100k}{N} + R_{SET}$$

where N is the number of LTM4600HVs in parallel.

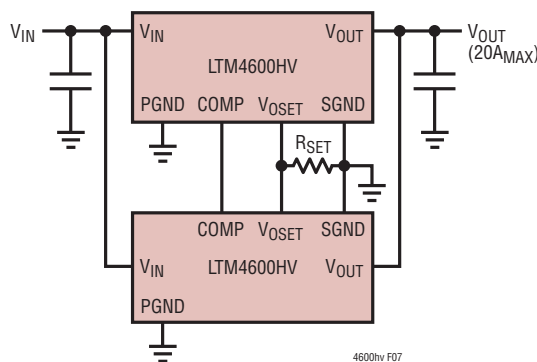

Figure 7. Parallel Two μ Modules with Load Sharing

Thermal Considerations and Output Current Derating

The power loss curves in Figures 8 and 15 can be used in coordination with the load current derating curves in Figures 9 to 14, and Figures 16 to 19 for calculating an approximate θ_{JA} for the module with various heat sinking methods. Thermal models are derived from several temperature measurements at the bench, and thermal modeling analysis. Application Note 103 provides a detailed

explanation of the analysis for the thermal models, and the derating curves. Tables 3 and 4 provide a summary of the equivalent θ_{JA} for the noted conditions. These equivalent θ_{JA} parameters are correlated to the measure values, and improved with air-flow. The case temperature is maintained at 100°C or below for the derating curves. This allows for 4W maximum power dissipation in the total module with top and bottom heat sinking, and 2W power dissipation through the top of the module with an approximate θ_{JC} between 6°C/W to 9°C/W. This equates to a total of 124°C at the junction of the device.

Safety Considerations

The LTM4600HV modules do not provide isolation from V_{IN} to V_{OUT} . There is no internal fuse. If required, a slow blow fuse with a rating twice the maximum input current should be provided to protect each unit from catastrophic failure.

Layout Checklist/Example

The high integration of the LTM4600HV makes the PCB board layout very simple and easy. However, to optimize its electrical and thermal performance, some layout considerations are still necessary.

- Use large PCB copper areas for high current path, including V_{IN} , PGND and V_{OUT} . It helps to minimize the PCB conduction loss and thermal stress
- Place high frequency ceramic input and output capacitors next to the V_{IN} , PGND and V_{OUT} pins to minimize high frequency noise
- Place a dedicated power ground layer underneath the unit
- To minimize the via conduction loss and reduce module thermal stress, use multiple vias for interconnection between top layer and other power layers
- Do not put vias directly on pad unless they are capped.
- Use a separated SGND ground copper area for components connected to signal pins. Connect the SGND to PGND underneath the unit

Figure 20 gives a good example of the recommended layout.

APPLICATIONS INFORMATION

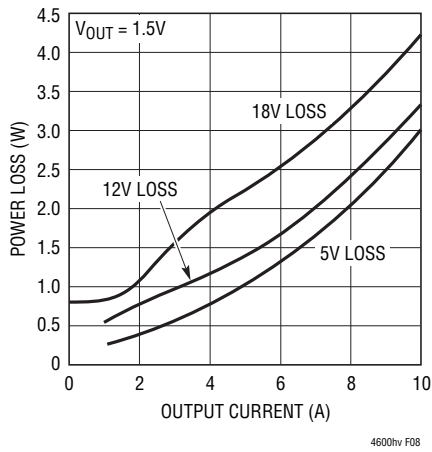

Figure 8. 1.5V Power Loss Curves vs Load Current

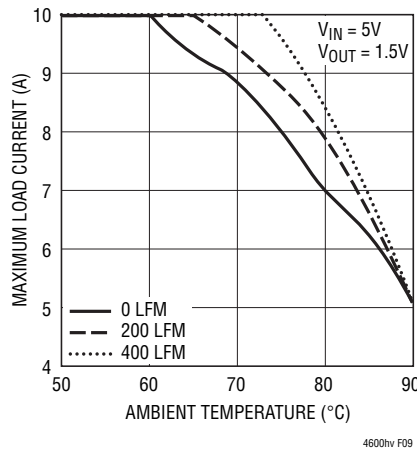

Figure 9. No Heat Sink

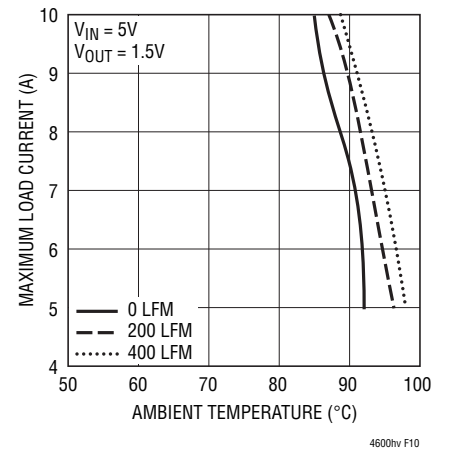

Figure 10. BGA Heat Sink

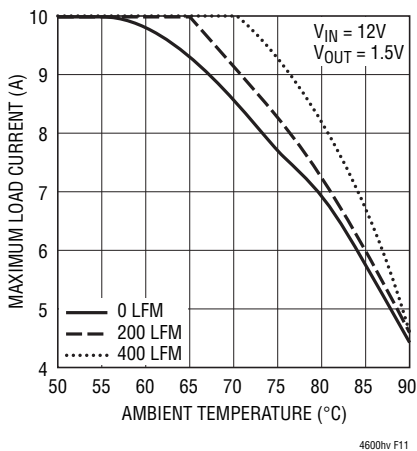

Figure 11. No Heat Sink

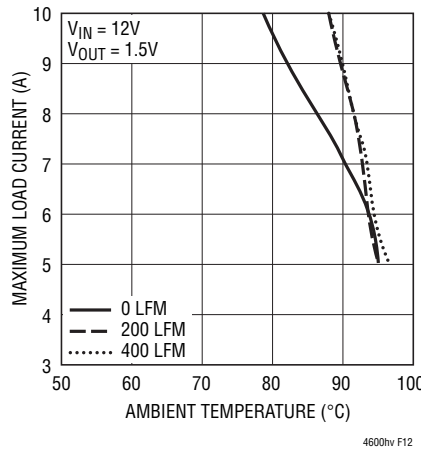

Figure 12. BGA Heat Sink

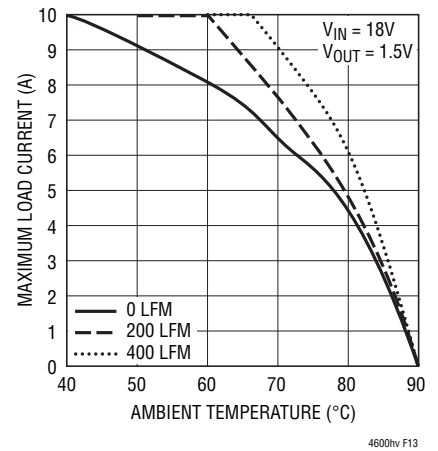

Figure 13. No Heat Sink

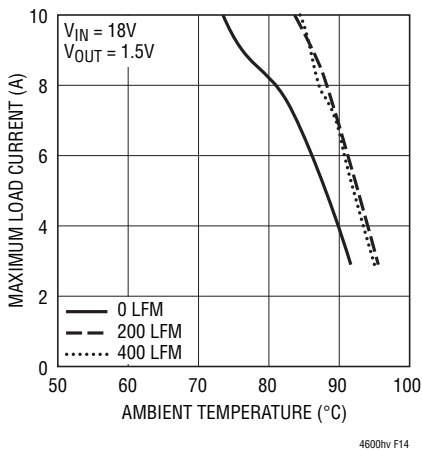

Figure 14. BGA Heat Sink

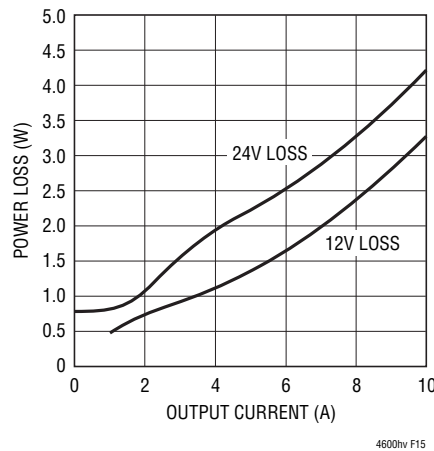

Figure 15. 3.3V Power Loss Curves vs Load Current

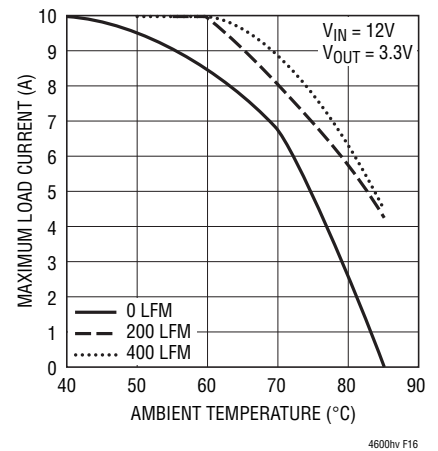

Figure 16. No Heat Sink

APPLICATIONS INFORMATION

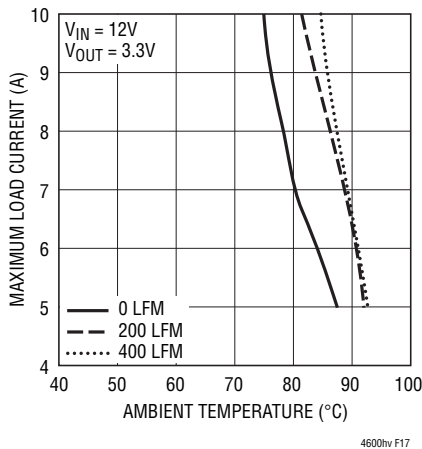

Figure 17. BGA Heat Sink

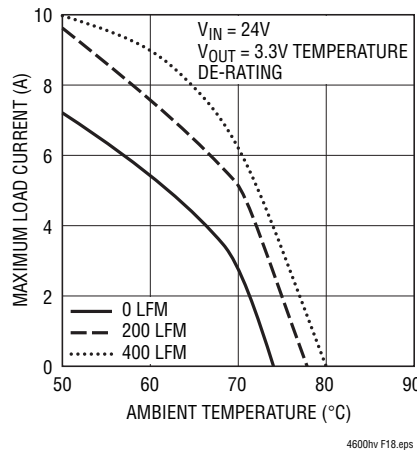

Figure 18. No Heat Sink

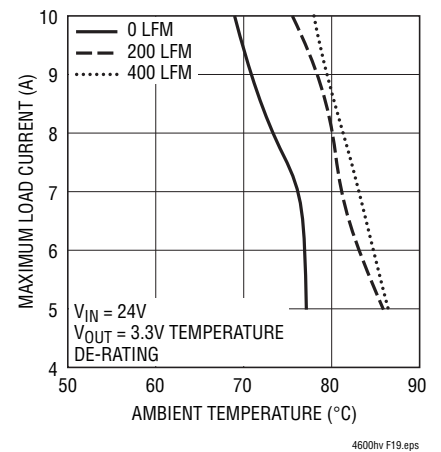

Figure 19. BGA Heat Sink

Table 3. 1.5V Output

DERATING CURVE	V_{IN} (V)	POWER LOSS CURVE	AIR FLOW (LFM)	HEAT SINK	θ_{JA} (°C/W)
Figures 9, 11, 13	5, 12, 18	Figure 8	0	None	15.2
Figures 9, 11, 13	5, 12, 18	Figure 8	200	None	14
Figures 9, 11, 13	5, 12, 18	Figure 8	400	None	12
Figures 10, 12, 14	5, 12, 18	Figure 8	0	BGA Heat Sink	13.9
Figures 10, 12, 14	5, 12, 18	Figure 8	200	BGA Heat Sink	11.3
Figures 10, 12, 14	5, 12, 18	Figure 8	400	BGA Heat Sink	10.25

Table 4. 3.3V Output

DERATING CURVE	V_{IN} (V)	POWER LOSS CURVE	AIR FLOW (LFM)	HEAT SINK	θ_{JA} (°C/W)
Figures 16, 18	12, 24	Figure 15	0	None	15.2
Figures 16, 18	12, 24	Figure 15	200	None	14.6
Figures 16, 18	12, 24	Figure 15	400	None	13.4
Figures 17, 19	12, 24	Figure 15	0	BGA Heat Sink	13.9
Figures 17, 19	12, 24	Figure 15	200	BGA Heat Sink	11.1
Figures 17, 19	12, 24	Figure 15	400	BGA Heat Sink	10.5

APPLICATIONS INFORMATION

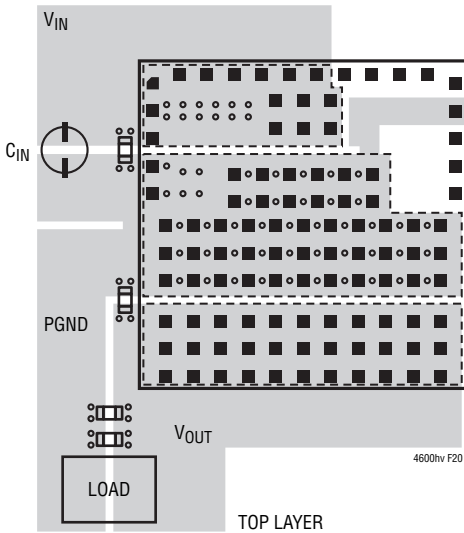
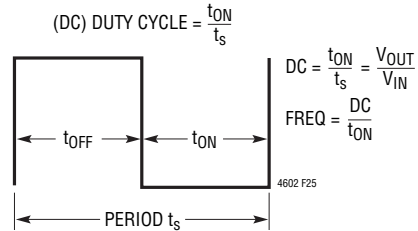

Figure 20. Recommended PCB Layout

LTM4600HV Frequency Adjustment

The LTM4600HV is designed to typically operate at 850kHz across most input and output conditions. The control architecture is constant on time valley mode current control. The f_{ADJ} pin is typically left open or decoupled with an optional 1000pF capacitor. The switching frequency has been optimized to maintain constant output ripple over the operating conditions. The equations for setting the operating frequency are set around a programmable constant on time. This on time is developed by a programmable current into an on board 10pF capacitor that establishes a ramp that is compared to a voltage threshold equal to the output voltage up to a 2.4V clamp. This I_{ON} current is equal to: $I_{ON} = (V_{IN} - 0.7V)/110k$, with the 110k onboard resistor from V_{IN} to f_{ADJ} . The on time is equal to $t_{ON} = (V_{OUT}/I_{ON}) \cdot 10pF$ and $t_{OFF} = t_s - t_{ON}$. The frequency is equal to: $Freq. = DC/t_{ON}$. The I_{ON} current is proportional to V_{IN} , and the regulator duty cycle is inversely proportional to V_{IN} , therefore the step-down regulator will remain relatively constant frequency as the duty cycle adjustment takes place with lowering V_{IN} . The on time is proportional to V_{OUT} up to a 2.4V clamp. This will hold frequency relatively constant with different output voltages up to 2.4V. The regulator switching period is comprised of the on time and off time as depicted in the following waveform. The on time is equal to $t_{ON} = (V_{OUT}/I_{ON}) \cdot 10pF$ and $t_{OFF} = t_s - t_{ON}$. The frequency is equal to: $Frequency = DC/t_{ON}$.



The LTM4600HV has a minimum (t_{ON}) on time of 100 nanoseconds and a minimum (t_{OFF}) off time of 400 nanoseconds. The 2.4V clamp on the ramp threshold as a function of V_{OUT} will cause the switching frequency to increase by the ratio of $V_{OUT}/2.4V$ for 3.3V and 5V outputs. This is due to the fact the on time will not increase as V_{OUT} increases past 2.4V. Therefore, if the nominal switching frequency is 850kHz, then the switching frequency will increase to ~1.2MHz for 3.3V, and ~1.7MHz for 5V outputs due to $Frequency = (DC/t_{ON})$. When the switching frequency increases to 1.2MHz, then the time period t_s is reduced to ~833 nanoseconds and at 1.7MHz the switching period reduces to ~588 nanoseconds. When higher duty cycle conversions like 5V to 3.3V and 12V to 5V need to be accommodated, then the switching frequency can be lowered to alleviate the violation of the 400ns minimum off time. Since the total switching period is $t_s = t_{ON} + t_{OFF}$, t_{OFF} will be below the 400ns minimum off time. A resistor from the f_{ADJ} pin to ground can shunt current away from the on time generator, thus allowing for a longer on time and a lower switching frequency. 12V to 5V and 5V to 3.3V derivations are explained in the data sheet to lower switching frequency and accommodate these step-down conversions.

Equations for setting frequency for 12V to 5V:

$$I_{ON} = (V_{IN} - 0.7V)/110k; I_{ON} = 103\mu A$$

$$frequency = (I_{ON}/[2.4V \cdot 10pF]) \cdot DC = 1.79MHz;$$

DC = duty cycle, duty cycle is (V_{OUT}/V_{IN})

$$t_s = t_{ON} + t_{OFF}, t_{ON} = \text{on-time}, t_{OFF} = \text{off-time of the switching period}; t_s = 1/frequency$$

t_{OFF} must be greater than 400ns, or $t_s - t_{ON} > 400ns$.

$$t_{ON} = DC \cdot t_s$$

1MHz frequency or 1 μ s period is chosen for 12V to 5V.

APPLICATIONS INFORMATION

$$t_{ON} = 0.41 \cdot 1\mu s \approx 410ns$$

$$t_{OFF} = 1\mu s - 410ns \approx 590ns$$

t_{ON} and t_{OFF} are above the minimums with adequate guard band.

Using the frequency = $(I_{ON}/[2.4V \cdot 10pF]) \cdot DC$, solve for $I_{ON} = (1MHz \cdot 2.4V \cdot 10pF) \cdot (1/0.41) \approx 58\mu A$. I_{ON} current calculated from 12V input was $103\mu A$, so a resistor from f_{ADJ} to ground = $(0.7V/15k) = 46\mu A$. $103\mu A - 46\mu A = 57\mu A$, sets the adequate I_{ON} current for proper frequency range for the higher duty cycle conversion of 12V to 5V. Input voltage range is limited to 9V to 16V. Higher input voltages can be used without the 15k on f_{ADJ} . The inductor ripple current gets too high above 16V, and the 400ns minimum off-time is limited below 9V.

Equations for setting frequency for 5V to 3.3V:

$$I_{ON} = (V_{IN} - 0.7V)/110k; I_{ON} = 39\mu A$$

$$\text{frequency} = (I_{ON}/[2.4V \cdot 10pF]) \cdot DC = 1.07MHz;$$

$$DC = \text{duty cycle, duty cycle is } (V_{OUT}/V_{IN})$$

$$t_S = t_{ON} + t_{OFF}, t_{ON} = \text{on-time, } t_{OFF} = \text{off-time of the switching period; } t_S = 1/\text{frequency}$$

t_{OFF} must be greater than 400ns, or $t_S - t_{ON} > 400ns$.

$$t_{ON} = DC \cdot t_S$$

~450kHz frequency or 2.22 μs period is chosen for 5V to 3.3V. Frequency range is about 450kHz to 650kHz from 4.5V to 7V input.

$$t_{ON} = 0.66 \cdot 2.22\mu s \approx 1.46\mu s$$

$$t_{OFF} = 2.22\mu s - 1.46\mu s \approx 760ns$$

t_{ON} and t_{OFF} are above the minimums with adequate guard band.

Using the frequency = $(I_{ON}/[2.4V \cdot 10pF]) \cdot DC$, solve for $I_{ON} = (450kHz \cdot 2.4V \cdot 10pF) \cdot (1/0.66) \approx 16\mu A$. I_{ON} current calculated from 5V input was $39\mu A$, so a resistor from f_{ADJ} to ground = $(0.7V/30.1k) = 23\mu A$. $39\mu A - 23\mu A = 16\mu A$, sets the adequate I_{ON} current for proper frequency range for the higher duty cycle conversion of 5V to 3.3V. Input voltage range is limited to 4.5V to 7V. Higher input voltages can be used without the 30.1k on f_{ADJ} . The inductor ripple current gets too high above 7V, and the 400ns minimum off-time is limited below 4.5V.

5V to 3.3V at 8A

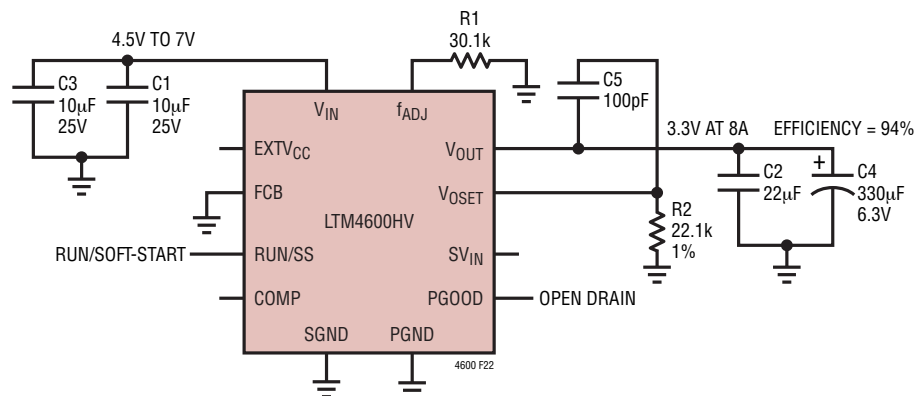

5V TO 3.3V AT 8A WITH $f_{ADJ} = 30.1k$
LTM4600HV MINIMUM ON-TIME = 100ns
LTM4600HV MINIMUM OFF-TIME = 400ns

C1, C3: TDK C3216X5R1E106MT
C2: TAIYO YUDEN, JMK316BJ226ML
C4: SANYO POSCAP, 6TPE330MIL

APPLICATIONS INFORMATION

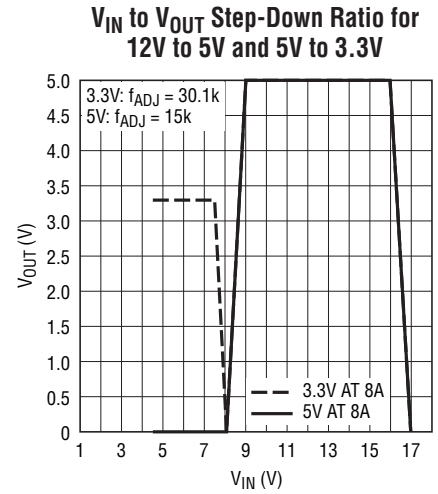
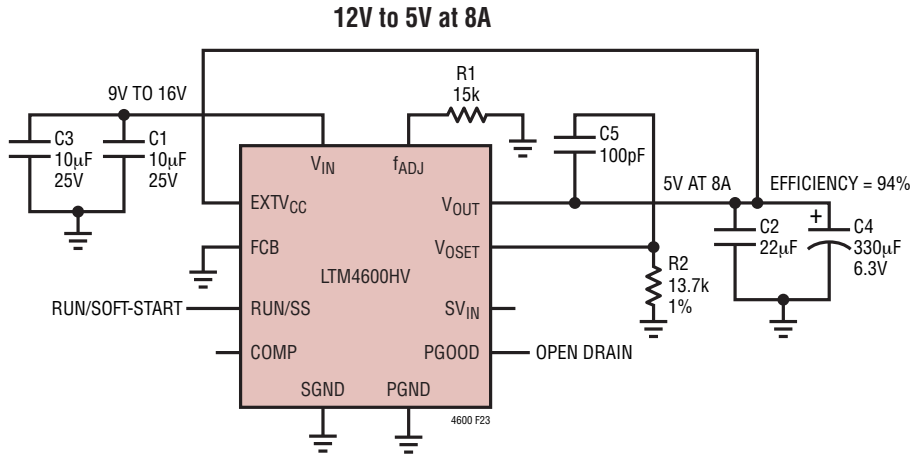

12V TO 5V AT 8A WITH $f_{ADJ} = 15k$
 LTM4600HV MINIMUM ON-TIME = 100ns
 LTM4600HV MINIMUM OFF-TIME = 400ns

C1, C3: TDK C3216X5R1E106MT
 C2: TAIYO YUDEN, JMK316BJ226ML
 C4: SANYO POSCAP, 6TPE330MIL

4600 F24

TYPICAL APPLICATIONS

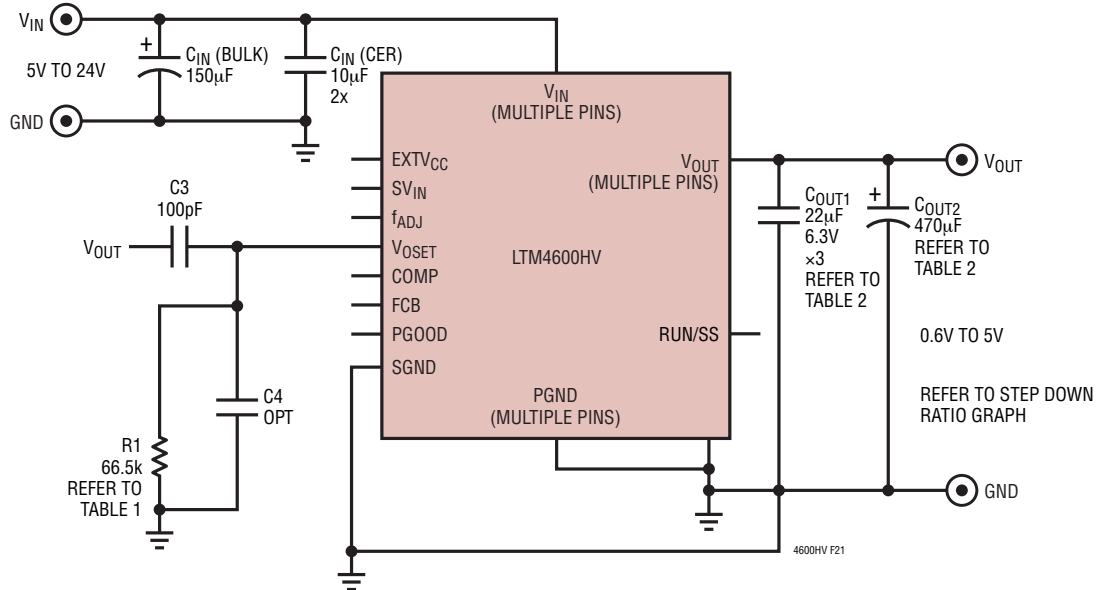
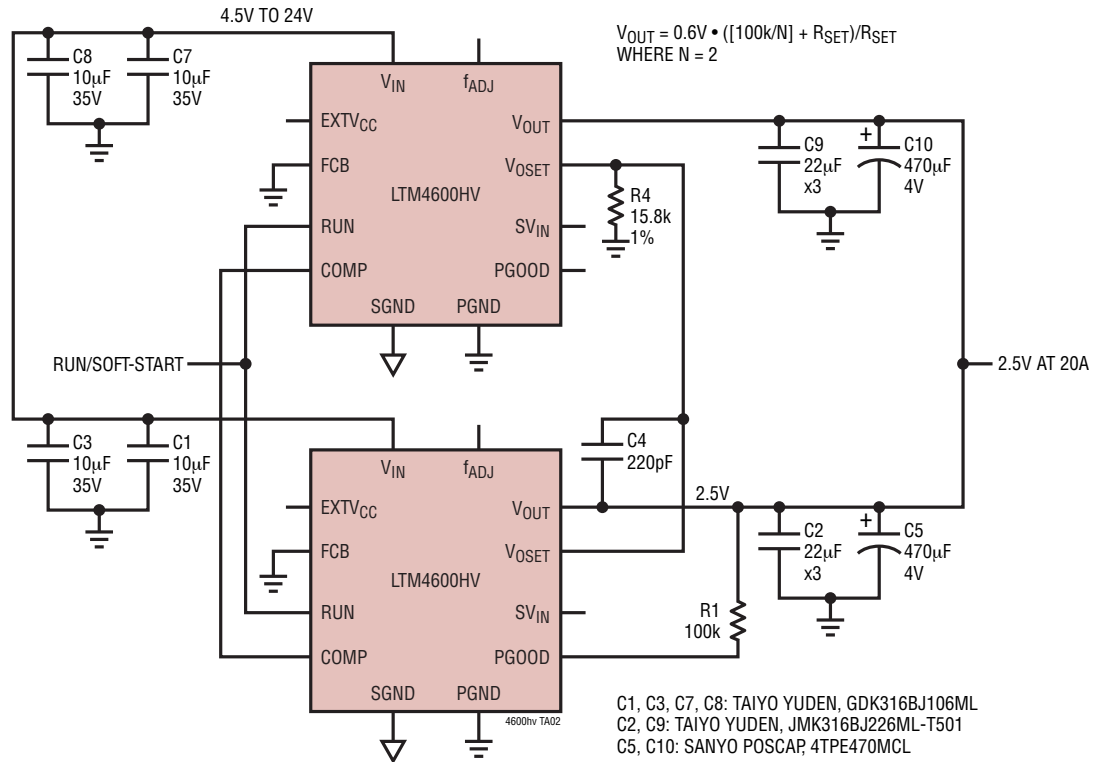

Figure 21. Typical Application, 5V to 24V Input, 0.6V to 5V Output, 10A Max

TYPICAL APPLICATIONS

Parallel Operation and Load Sharing



Current Sharing Between Two LTM4600HV Modules

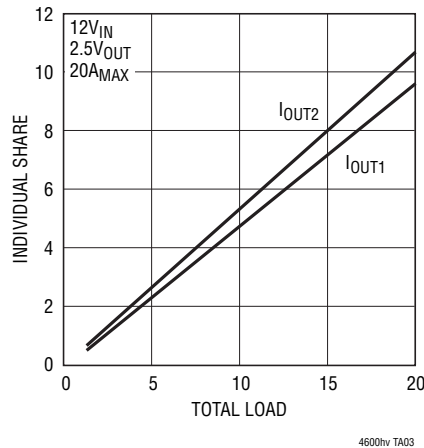

LGA Package
104-Lead (15mm × 15mm × 2.82mm)
 (Reference LTM DWG # 05-05-1800 Rev C)

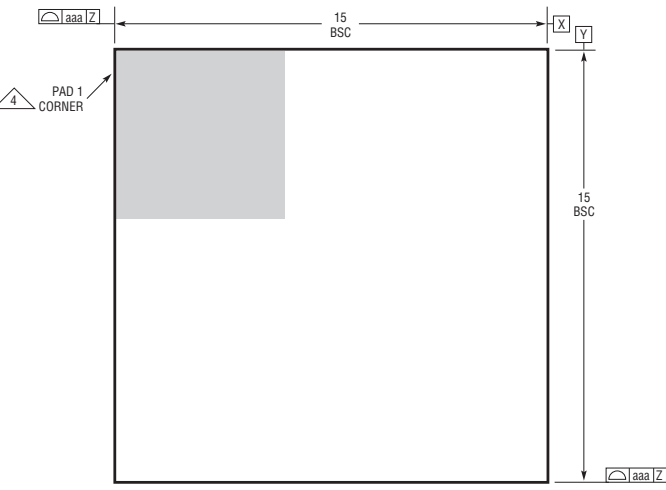
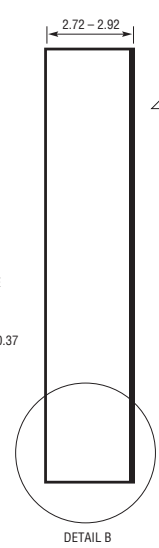
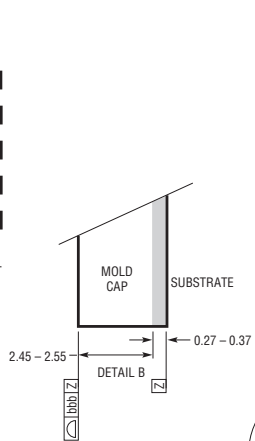
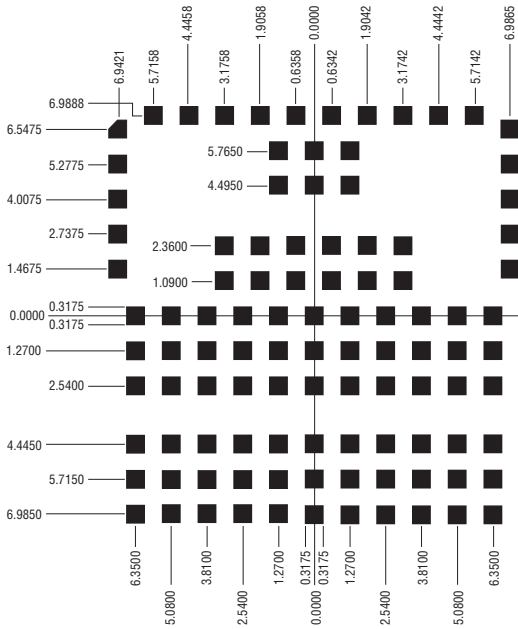

TOP VIEW

SUGGESTED SOLDER PAD LAYOUT
 TOP VIEW

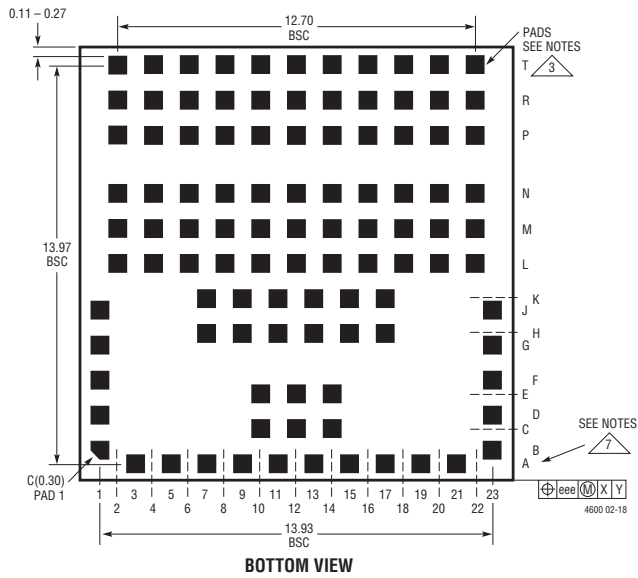

BOTTOM VIEW

NOTES:

1. DIMENSIONING AND TOLERANCING PER ASME Y14.5M-1994
2. ALL DIMENSIONS ARE IN MILLIMETERS
- 3 LAND DESIGNATION PER JESD MO-222, SPP-010
- 4 DETAILS OF PAD #1 IDENTIFIER ARE OPTIONAL, BUT MUST BE LOCATED WITHIN THE ZONE INDICATED. THE PAD #1 IDENTIFIER IS A MARKED FEATURE OR A NOTCHED BEVELED PAD
5. PRIMARY DATUM -Z- IS SEATING PLANE
6. THE TOTAL NUMBER OF PADS: 104
- 7 PACKAGE ROW AND COLUMN LABELING MAY VARY AMONG μModule PRODUCTS. REVIEW EACH PACKAGE LAYOUT CAREFULLY

SYMBOL	TOLERANCE
aaa	0.15
bbb	0.10
eee	0.15

LGA 104 1112 REV C

PACKAGE DESCRIPTION
 Please refer to <http://www.linear.com/designtools/packaging/> for the most recent package drawings.

LTM4600HV

PACKAGE DESCRIPTION

Pin Assignment Tables
(Arranged by Pin Number)

PIN NAME	PIN NAME	PIN NAME	PIN NAME	PIN NAME	PIN NAME	PIN NAME	PIN NAME
A1 -	B1 V_{IN}	C1 -	D1 V_{IN}	E1 -	F1 V_{IN}	G1 PGND	H1 -
A2 -	B2 -	C2 -	D2 -	E2 -	F2 -	G2 -	H2 -
A3 V_{IN}	B3 -	C3 -	D3 -	E3 -	F3 -	G3 -	H3 -
A4 -	B4 -	C4 -	D4 -	E4 -	F4 -	G4 -	H4 -
A5 V_{IN}	B5 -	C5 -	D5 -	E5 -	F5 -	G5 -	H5 -
A6 -	B6 -	C6 -	D6 -	E6 -	F6 -	G6 -	H6 -
A7 V_{IN}	B7 -	C7 -	D7 -	E7 -	F7 -	G7 -	H7 PGND
A8 -	B8 -	C8 -	D8 -	E8 -	F8 -	G8 -	H8 -
A9 V_{IN}	B9 -	C9 -	D9 -	E9 -	F9 -	G9 -	H9 PGND
A10 -	B10 -	C10 V_{IN}	D10 -	E10 V_{IN}	F10 -	G10 -	H10 -
A11 V_{IN}	B11 -	C11 -	D11 -	E11 -	F11 -	G11 -	H11 PGND
A12 -	B12 -	C12 V_{IN}	D12 -	E12 V_{IN}	F12 -	G12 -	H12 -
A13 V_{IN}	B13 -	C13 -	D13 -	E13 -	F13 -	G13 -	H13 PGND
A14 -	B14 -	C14 V_{IN}	D14 -	E14 V_{IN}	F14 -	G14 -	H14 -
A15 f_{ADJ}	B15 -	C15 -	D15 -	E15 -	F15 -	G15 -	H15 PGND
A16 -	B16 -	C16 -	D16 -	E16 -	F16 -	G16 -	H16 -
A17 SV_{IN}	B17 -	C17 -	D17 -	E17 -	F17 -	G17 -	H17 PGND
A18 -	B18 -	C18 -	D18 -	E18 -	F18 -	G18 -	H18 -
A19 $EXTV_{CC}$	B19 -	C19 -	D19 -	E19 -	F19 -	G19 -	H19 -
A20 -	B20 -	C20 -	D20 -	E20 -	F20 -	G20 -	H20 -
A21 V_{OSET}	B21 -	C21 -	D21 -	E21 -	F21 -	G21 -	H21 -
A22 -	B22 -	C22 -	D22 -	E22 -	F22 -	G22 -	H22 -
A23 -	B23 COMP	C23 -	D23 SGND	E23 -	F23 RUN/SS	G23 FCB	H23 -

PIN NAME	PIN NAME	PIN NAME	PIN NAME	PIN NAME	PIN NAME	PIN NAME	PIN NAME
J1 PGND	K1 -	L1 -	M1 -	N1 -	P1 -	R1 -	T1 -
J2 -	K2 -	L2 PGND	M2 PGND	N2 PGND	P2 V_{OUT}	R2 V_{OUT}	T2 V_{OUT}
J3 -	K3 -	L3 -	M3 -	N3 -	P3 -	R3 -	T3 -
J4 -	K4 -	L4 PGND	M4 PGND	N4 PGND	P4 V_{OUT}	R4 V_{OUT}	T4 V_{OUT}
J5 -	K5 -	L5 -	M5 -	N5 -	P5 -	R5 -	T5 -
J6 -	K6 -	L6 PGND	M6 PGND	N6 PGND	P6 V_{OUT}	R6 V_{OUT}	T6 V_{OUT}
J7 -	K7 PGND	L7 -	M7 -	N7 -	P7 -	R7 -	T7 -
J8 -	K8 -	L8 PGND	M8 PGND	N8 PGND	P8 V_{OUT}	R8 V_{OUT}	T8 V_{OUT}
J9 -	K9 PGND	L9 -	M9 -	N9 -	P9 -	R9 -	T9 -
J10 -	K10 -	L10 PGND	M10 PGND	N10 PGND	P10 V_{OUT}	R10 V_{OUT}	T10 V_{OUT}
J11 -	K11 PGND	L11 -	M11 -	N11 -	P11 -	R11 -	T11 -
J12 -	K12 -	L12 PGND	M12 PGND	N12 PGND	P12 V_{OUT}	R12 V_{OUT}	T12 V_{OUT}
J13 -	K13 PGND	L13 -	M13 -	N13 -	P13 -	R13 -	T13 -
J14 -	K14 -	L14 PGND	M14 PGND	N14 PGND	P14 V_{OUT}	R14 V_{OUT}	T14 V_{OUT}
J15 -	K15 PGND	L15 -	M15 -	N15 -	P15 -	R15 -	T15 -
J16 -	K16 -	L16 PGND	M16 PGND	N16 PGND	P16 V_{OUT}	R16 V_{OUT}	T16 V_{OUT}
J17 -	K17 PGND	L17 -	M17 -	N17 -	P17 -	R17 -	T17 -
J18 -	K18 -	L18 PGND	M18 PGND	N18 PGND	P18 V_{OUT}	R18 V_{OUT}	T18 V_{OUT}
J19 -	K19 -	L19 -	M19 -	N19 -	P19 -	R19 -	T19 -
J20 -	K20 -	L20 PGND	M20 PGND	N20 PGND	P20 V_{OUT}	R20 V_{OUT}	T20 V_{OUT}
J21 -	K21 -	L21 -	M21 -	N21 -	P21 -	R21 -	T21 -
J22 -	K22 -	L22 PGND	M22 PGND	N22 PGND	P22 V_{OUT}	R22 V_{OUT}	T22 V_{OUT}
J23 PGOOD	K23 -	L23 -	M23 -	N23 -	P23 -	R23 -	T23 -

PACKAGE DESCRIPTION

Pin Assignment Tables
(Arranged by Pin Number)

PIN NAME		PIN NAME		PIN NAME		PIN NAME	
G1	PGND	P2	V _{OUT}	A3	V _{IN}	A15	f _{ADJ}
H7	PGND	P4	V _{OUT}	A5	V _{IN}	A17	SV _{IN}
H9	PGND	P6	V _{OUT}	A7	V _{IN}	A19	EXTV _{CC}
H11	PGND	P8	V _{OUT}	A9	V _{IN}	A21	V _{OSET}
H13	PGND	P10	V _{OUT}	A11	V _{IN}	B23	COMP
H15	PGND	P12	V _{OUT}	A13	V _{IN}	D23	SGND
H17	PGND	P14	V _{OUT}	B1	V _{IN}	F23	RUN/SS
J1	PGND	P16	V _{OUT}	C10	V _{IN}	G23	FCB
K7	PGND	P18	V _{OUT}	C12	V _{IN}	J23	PGOOD
K9	PGND	P20	V _{OUT}	C14	V _{IN}		
K11	PGND	P22	V _{OUT}	D1	V _{IN}		
K13	PGND	R2	V _{OUT}	E10	V _{IN}		
K15	PGND	R4	V _{OUT}	E12	V _{IN}		
K17	PGND	R6	V _{OUT}	E14	V _{IN}		
L2	PGND	R8	V _{OUT}	F1	V _{IN}		
L4	PGND	R10	V _{OUT}				
L6	PGND	R12	V _{OUT}				
L8	PGND	R14	V _{OUT}				
L10	PGND	R16	V _{OUT}				
L12	PGND	R18	V _{OUT}				
L14	PGND	R20	V _{OUT}				
L16	PGND	R22	V _{OUT}				
L18	PGND	T2	V _{OUT}				
L20	PGND	T4	V _{OUT}				
L22	PGND	T6	V _{OUT}				
M2	PGND	T8	V _{OUT}				
M4	PGND	T10	V _{OUT}				
M6	PGND	T12	V _{OUT}				
M8	PGND	T14	V _{OUT}				
M10	PGND	T16	V _{OUT}				
M12	PGND	T18	V _{OUT}				
M14	PGND	T20	V _{OUT}				
M16	PGND	T22	V _{OUT}				
M18	PGND						
M20	PGND						
M22	PGND						
N2	PGND						
N4	PGND						
N6	PGND						
N8	PGND						
N10	PGND						
N12	PGND						
N14	PGND						
N16	PGND						
N18	PGND						
N20	PGND						
N22	PGND						

REVISION HISTORY (Revision history begins at Rev E)

REV	DATE	DESCRIPTION	PAGE NUMBER
E	5/14	Added reflow temperature.	2
		Updated the Order Table.	2
		Updated Notes.	4
		Updated the Soft-Start and Latchoff section.	11, 13