



Chipsmall Limited consists of a professional team with an average of over 10 year of expertise in the distribution of electronic components. Based in Hongkong, we have already established firm and mutual-benefit business relationships with customers from,Europe,America and south Asia,supplying obsolete and hard-to-find components to meet their specific needs.

With the principle of “Quality Parts,Customers Priority,Honest Operation,and Considerate Service”,our business mainly focus on the distribution of electronic components. Line cards we deal with include Microchip,ALPS,ROHM,Xilinx,Pulse,ON,Everlight and Freescale. Main products comprise IC,Modules,Potentiometer,IC Socket,Relay,Connector.Our parts cover such applications as commercial,industrial, and automotives areas.

We are looking forward to setting up business relationship with you and hope to provide you with the best service and solution. Let us make a better world for our industry!



Contact us

Tel: +86-755-8981 8866 Fax: +86-755-8427 6832

Email & Skype: info@chipsmall.com Web: www.chipsmall.com

Address: A1208, Overseas Decoration Building, #122 Zhenhua RD., Futian, Shenzhen, China





Test Procedure for the LV47004PGEVB Evaluation Board

TEST Procedure

Prepare “DC POWER SUPPLY”, capability is 40V or more and 20A or more. And “Digital MULTIMETER”, and “4ohm speaker” and “Oscillator” and “4ch Oscilloscope” and “Heat sink”

1. Recommendation “Heat sink”

Material: Aluminium alloy (A6000 type)

Surface treatment: Alumite (color : black)

Thermal resistance of heat sink (θ_f): 3 degree C/W

Thermal resistance between the junction and case: 1 degree C/W

$\theta_{jc} + \theta_f = 4$ degree C/W

$\{ 150 \text{ degree C}(T_{jmax}) - 25 \text{ degree C}(T_a) \} \div 4 \text{ degree C/W} \rightarrow P_{dmax} \approx 30W$

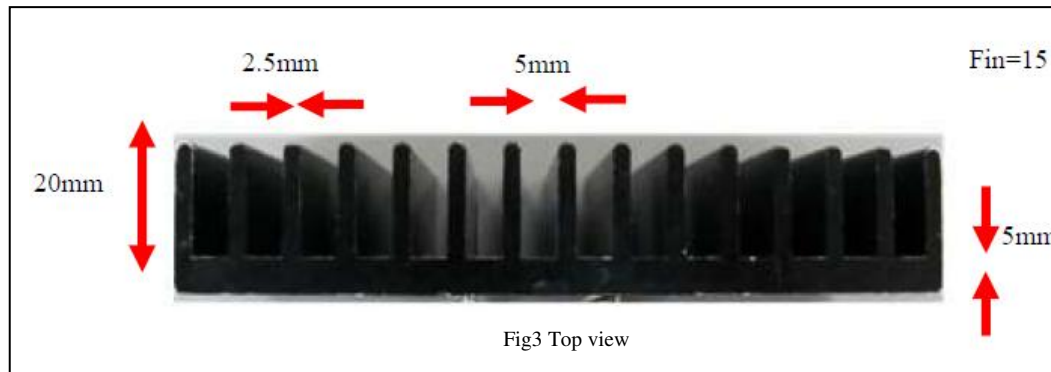
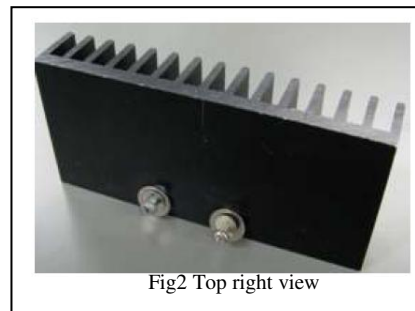
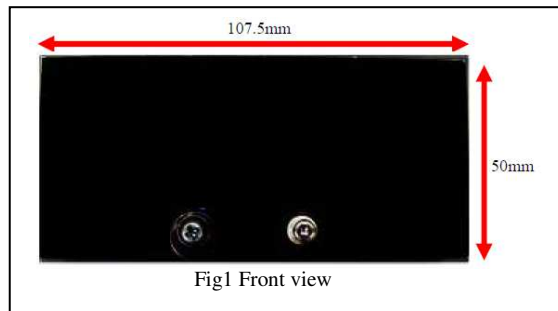



2. Eva-board and Measurement instruments of cable connection.

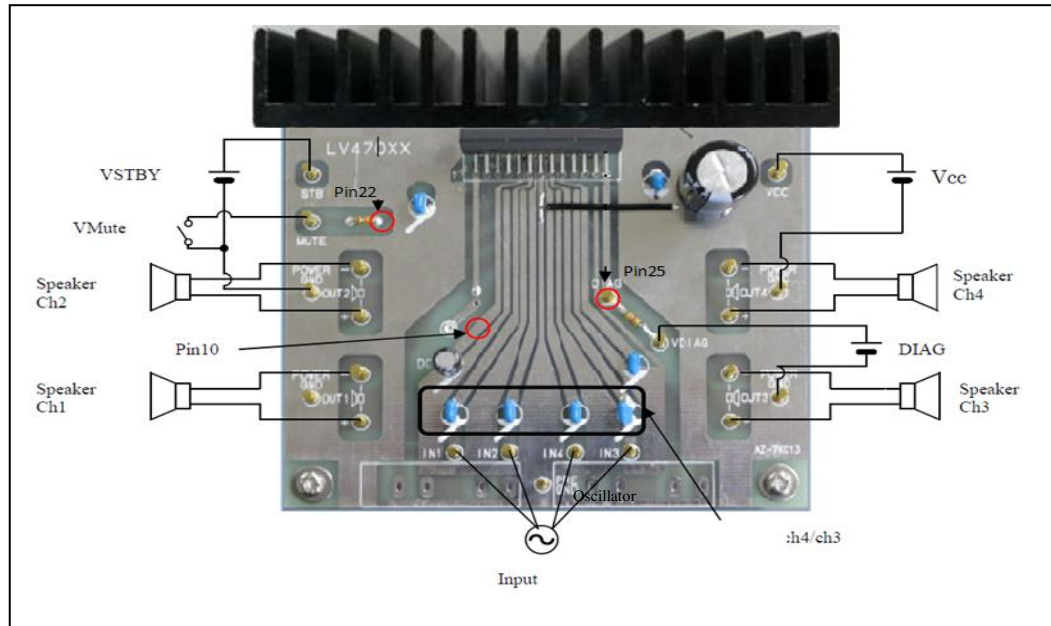

3. VCC, Input, Output operation sequence Start up

- A. Vcc ON (Vcc=8V to 18V)
- B. AMP ON (STBY Pin=High: VSTBY=2.5V to Vcc)
- C. Mute OFF (Mute Pin=open: VMute switch close → open)
- E. Input signal ON

Shutdown

- F. Input signal OFF
- G. Mute ON (Mute Pin=Low: Vmute switch open → close)
- H. AMP OFF (STBY Pin=Low: VSTBY=0V)
- I. Vcc OFF