



Chipsmall Limited consists of a professional team with an average of over 10 year of expertise in the distribution of electronic components. Based in Hongkong, we have already established firm and mutual-benefit business relationships with customers from,Europe,America and south Asia,supplying obsolete and hard-to-find components to meet their specific needs.

With the principle of "Quality Parts,Customers Priority,Honest Operation,and Considerate Service",our business mainly focus on the distribution of electronic components. Line cards we deal with include Microchip,ALPS,ROHM,Xilinx,Pulse,ON,Everlight and Freescale. Main products comprise IC,Modules,Potentiometer,IC Socket,Relay,Connector.Our parts cover such applications as commercial,industrial, and automotives areas.

We are looking forward to setting up business relationship with you and hope to provide you with the best service and solution. Let us make a better world for our industry!



## Contact us

Tel: +86-755-8981 8866 Fax: +86-755-8427 6832

Email & Skype: info@chipsmall.com Web: www.chipsmall.com

Address: A1208, Overseas Decoration Building, #122 Zhenhua RD., Futian, Shenzhen, China





ON Semiconductor®

<http://onsemi.com>

# LV5207LP

Bi-CMOS IC

## LED Driver for Cellular Phone

### Overview

The LV5207LP is an LED driver IC for cellular phones. It incorporates 7 LED drivers (tricolor and main) and a charge pump circuit. The LV5207LP allows each LED current value to be regulated by a serial bus and has a function to synchronize a ringtone melody.

### Functions

- Charge pump
  - ×1/×1.5 mode switchover
  - The mode switches (step-up only and no step down) when the LED pin voltage goes down. When VBAT is 4.6V and above, this IC becomes only ×1 mode.
- LED drivers
  - Main LCD backlight LED×4 (LED current 5-bit changeover 0.8mA to 19.4mA)
  - Tricolor LED driver×1 (LED current 5-bit changeover 0.8mA to 19.4mA)

### Specifications

**Maximum Ratings** at  $T_a = 25^\circ\text{C}$

Parameter	Symbol	Conditions	Ratings	Unit
Maximum supply voltage	$V_{CC \text{ max}}$		4.5	V
Maximum pin voltage	$V_1 \text{ max}$	LED driver and charge pump blocks	7	V
Allowable power dissipation	$P_d \text{ max}$	Mounted on a board*	0.8	W
Operating temperature	$T_{opr}$		-30 to +75	$^\circ\text{C}$
Storage temperature	$T_{stg}$		-40 to +125	$^\circ\text{C}$

\* Designated board : 40mm×50mm×0.8mm, glass epoxy 4-layer board (2S2P)

Stresses exceeding Maximum Ratings may damage the device. Maximum Ratings are stress ratings only. Functional operation above the Recommended Operating Conditions is not implied. Extended exposure to stresses above the Recommended Operating Conditions may affect device reliability.

# LV5207LP

## Recommended Operating Conditions at Ta = 25°C

Parameter	Symbol	Conditions	Ratings	Unit
Supply voltage 1	V <sub>BAT</sub>		3.0 to 4.5	V
Supply voltage 2	V <sub>DD</sub>		1.7 to V <sub>BAT</sub>	V

## Electrical Characteristics Ta = 25°C, V<sub>BAT</sub> = 3.7V

Parameter	Symbol	Conditions	Ratings			Unit
			min	typ	max	
Current drain	I <sub>CC1</sub>	STBY : L (standby mode)		0	5	μA
	I <sub>CC2</sub>	STBY : H (sleep mode)		0.3	5	μA
	I <sub>CC3</sub>	Charge pump opetates.		4	7	mA
<b>Charge pump block</b>						
Output voltage	V <sub>O1</sub>	I <sub>O</sub> = 100mA, ×1		3.4		V
	V <sub>O2</sub>	I <sub>O</sub> = 100mA, ×1.5		4.7		V
Load current		×1.5 mode	120			mA
<b>Charge pump switchover voltage</b>						
Threshold voltage 1	VD1	LED pin voltage, when main current is set to 20mA	0.32	0.35	0.38	V
<b>Charge pump clock block</b>						
Clock frequency	Fosc		400	500	600	kHz
<b>LED driver block</b>						
Minimum output current 1	I <sub>MIN1</sub>	Tricolor LED driver serial data = #00	0.2	0.8	1.7	mA
Minimum output current 3	I <sub>MIN3</sub>	Main LED driver serial data = #00	0.2	0.8	1.7	mA
Maximum output current 1	I <sub>MAX1</sub>	Tricolor LED driver serial data = #FF	18.4	19.4	20.4	mA
Maximum output current 3	I <sub>MAX3</sub>	Main LED driver serial data = #FF	18.4	19.4	20.4	mA
Nonlinearity error	LE	*1	-2		2	LSB
Differential linearity error	DLE	*2	-2		2	LSB
Maximum output current 1	ΔIL1	Tricolor LED driver maximum current setting V <sub>O</sub> = 4 to 0.35V	-10			%
Maximum output current 3	ΔIL3	Main LED driver maximum current setting V <sub>O</sub> = 2 to 0.35V	-10			%
Leakage current 1	IL1	Tricolor LED driver and LED driver : OFF V <sub>O</sub> = 5V			1	μA
Leakage current 3	IL3	Main LED driver and LED driver : OFF V <sub>O</sub> = 5V			1	μA
<b>Control circuit block</b>						
H level 1	V <sub>INH1</sub>	Input H level serial, SCTL	V <sub>DD</sub> ×0.8			V
L level 1	V <sub>INL1</sub>	Input L level serial, SCTL	0		V <sub>DD</sub> ×0.2	V
H level 2	V <sub>INH2</sub>	Input H level reset	1.5			V
L level 2	V <sub>INL2</sub>	Input L level reset	0		0.3	V

\*1 Nonlinearity error : Error from the ideal current value.

\*2 Differential linearity error : Error from the ideal increment when increase by a 1 bit is made.

# LV5207LP

## Package Dimensions

unit : mm (typ)  
3322

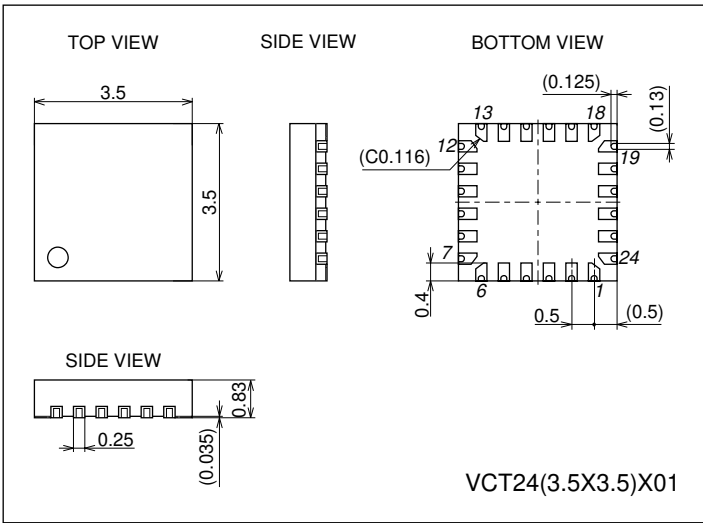

## Pin Assignment

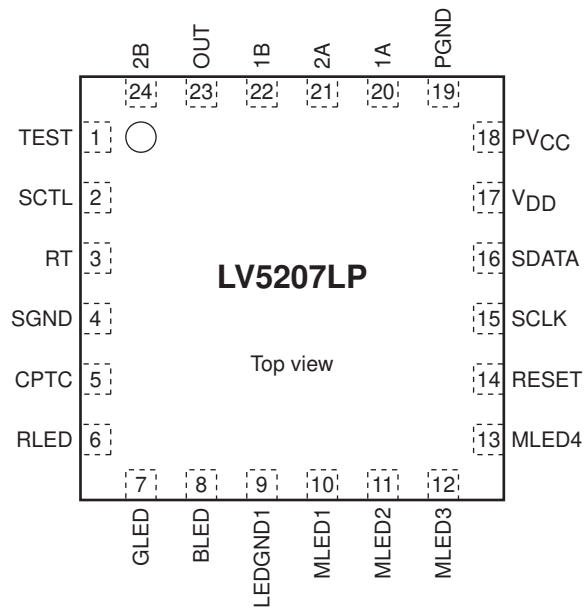

# LV5207LP

## Block Diagram and Sample Application Circuit

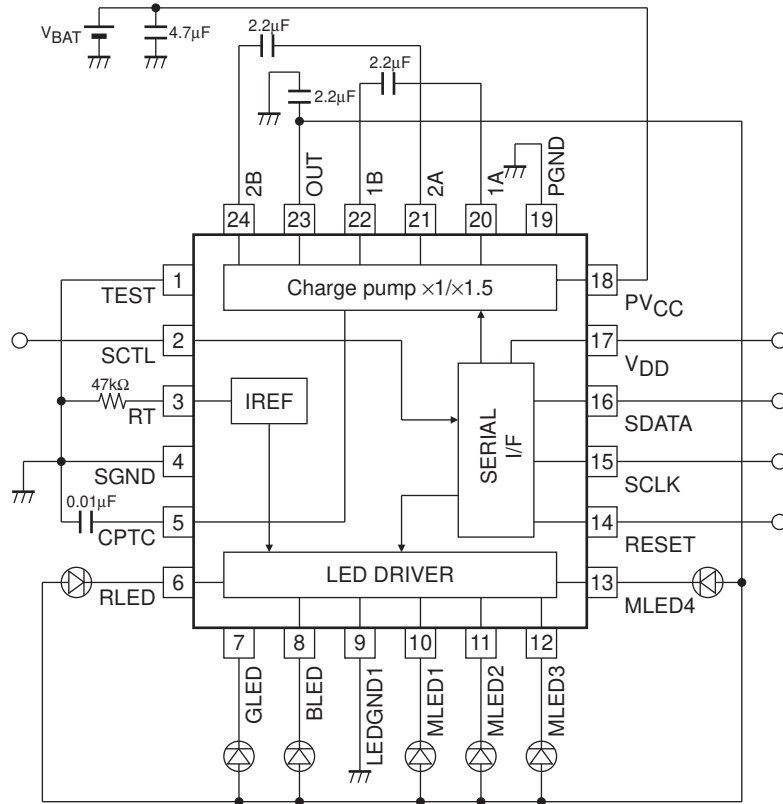

\* The value of the external capacitor connected to the charge pump circuit can be reduced depending on the load current. The minimum rating of the Load current doesn't increase even if 2.2µF or more capacitor is used.

### Pin Functions

Pin No.	Pin name	Pin Description	Equivalent Circuit
1	TEST	Test signal input pin. Be sure to connect the pin to GND.	
2	SCTL	External tricolor LED control pin. When serial RSW, GSW, and BSW are set to ON, setting the application voltage H causes tricolor LED to go ON. When the application voltage set to L, tricolor LED goes OFF. Note that if the serial setting STLEN is set to ignore SCTL, tricolor LED goes ON regardless of the state of SCTL.	
3	RT	Reference current setting resistor connection pin. By connecting the external resistor between this pin and GND, the reference current is generated. The pin voltage is about 1V. Change of this current value enables change of the oscillation frequency and LED driver current value.	
4	SGND	GND pin for circuits other than the power circuit	

Continued on next page.

# LV5207LP

Continued from preceding page.

Pin No.	Pin name	Pin Description	Equivalent Circuit
5	CPTC	Charge pump soft start capacitor connection pin. By connecting the capacitor, charge pump can be soft started. The pin is held high in STBY mode or when the charge pump output is short-circuited.	
6 7 8	RLED GLED BLED	Tricolor LED driver pins. Feedback is applied so that the current flow through the output transistor becomes equal to the set current value. Each driver output current value can be adjusted independently with the 0.6 step from about 0.8mA to 19.4mA through serial setting. These pins are turned ON only when the SCTL pin is set high or the serial SCTEN pin is set to ignore SCTL. These pins function as the charge pump switchover detection pin from ×1 mode to ×1.5 mode. Pin voltage of about 0.5V or lower switches the charge pump to ×1.5 mode.	
9	LEDGND1	GND pin dedicated to LED driver.	
10 11 12 13	MLED1 MLED2 MLED3 MLED4	Main LCD backlight LED driver pin. Feedback is applied so that the current flow through the output transistor becomes equal to the set current value. The driver current value can be adjusted with 0.6mA step from about 0.8mA to 19.4mA through serial setting. These pins function as the charge pump switchover detection pin from ×1 mode to ×1.5 mode. When MAX current is set, the pin voltage of about 0.35V or lower switches the charge pump to ×1.5 mode. If three MLED are used, MLED4 can be independently set ON/OFF with serial setting. Note that MLED4 :ON is active only with MSW:ON. Connect MLED4 pin to VBAT when it is not to be used.	
14	RESET	Reset signal input pin. The pin is in the reset state when it is set to L.	
15	SCLK	Serial clock input pin	
16	SDATA	Serial data signal input pin.	
17	VDD	Power pin for SCLK, SDATA, and SCTL pin input circuits.	
18	PVCC	Power pin	
19	PGND	GND pin for charge pump circuit	

Continued on next page.

# LV5207LP

Continued from preceding page.

Pin No.	Pin name	Pin Description	Equivalent Circuit
20 21	1A 2A	Charge pump clock driver pin.	
22	1B	Charge pump charge transfer driver pin.	
23	OUT	Charge pump output pin.	
24	2B	Charge pump charge transfer driver pin.	

## Serial Bus Communication Specifications

I<sup>2</sup>C serial transfer timing conditions

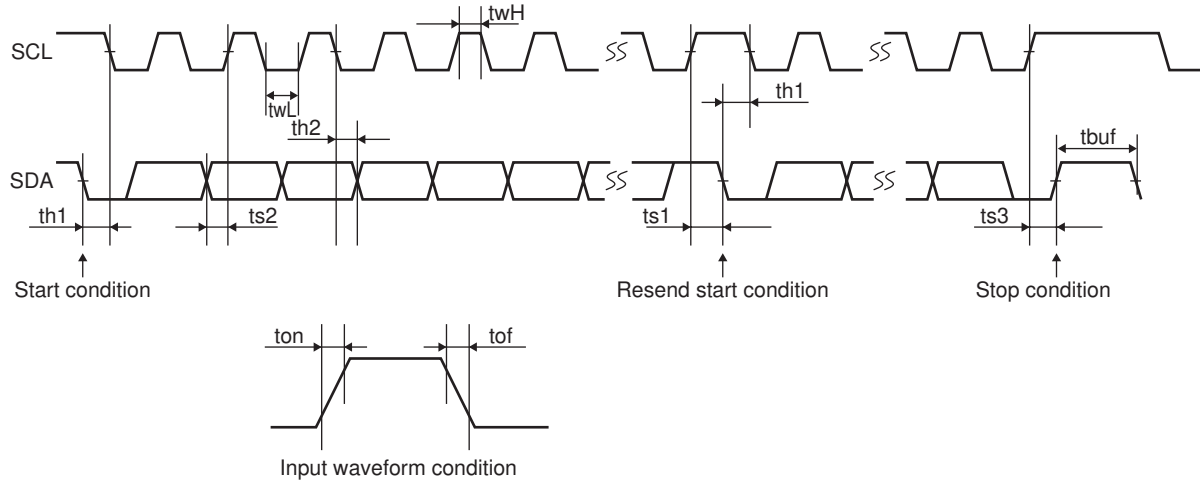

### Standard mode

Parameter	symbol	Conditions	min	typ	max	unit
SCL clock frequency	fsc1	SCL clock frequency	0		100	kHz
Data setup time	ts1	SCL setup time relative to falling edge of SDA	4.7			μs
	ts2	SDA setup time relative to rising edge of SCL	250			ns
	ts3	SCL setup time relative to rising edge of SDA	4.0			μs
Data hold time	th1	SCL hold time relative to rising edge of SDA	4.0			μs
	th2	SDA hold time relative to falling edge of SCL	0			μs
Pulse width	twL	SCL pulse width for the L period	4.7			μs
	twH	SCL pulse width for the H period	4.0			μs
Input waveform conditions	ton	SCL, SDA (input) rise time			1000	ns
	tof	SCL, SDA (input) fall time			300	ns
Bus free time	tbuf	Time between STOP and START conditions	4.7			μs

### High-speed mode

Parameter	Symbol	Conditions	min	typ	max	unit
SCL clock frequency	fsc1	SCL clock frequency	0		400	kHz
Data setup time	ts1	SCL setup time relative to falling edge of SDA	0.6			μs
	ts2	SDA setup time relative to rising edge of SCL	100			ns
	ts3	SCL setup time relative to rising edge of SDA	0.6			μs
Data hold time	th1	SCL hold time relative to rising edge of SDA	0.6			μs
	th2	SDA hold time relative to falling edge of SCL	0			μs
Pulse width	twL	SCL pulse width for the L period	1.3			μs
	twH	SCL pulse width for the H period	0.6			μs
Input waveform conditions	ton	SCL, SDA (input) rise time			300	ns
	tof	SCL, SDA (input) fall time			300	ns
Bus free time	tbuf	Time between STOP and START conditions	1.3			μs



# LV5207LP

## I<sup>2</sup>C bus transmission method

### Start and stop conditions

In the I<sup>2</sup>C bus, SDA must basically be kept in the constant state while SCL is "H" as shown below during data transfer.

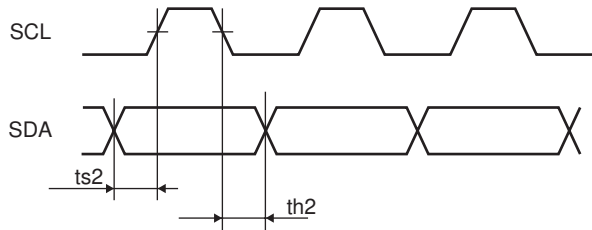

When data transfer is not made, both SCL and SDA are in the "H" state.

When SCL = SDA = "H", change of SDA from "H" to "L" enables the start conditions to start access.

When SCL is "H", change of SDA from "L" to "H" enables the stop conditions to stop access.

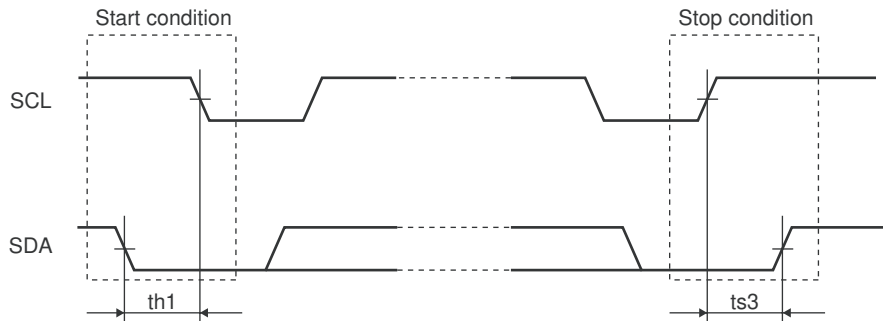

## Data transfer and acknowledgement response

After establishment of start conditions, data transfer is made by one byte (8 bits).

Data transfer enables continuous transfer of any number of bytes.

Each time the 8-bit data is transferred, the ACK signal is sent from the receive side to the send side.

The ACK signal is issued when SDA on the send side is released and SDA on the receive side is set "L" immediately after fall of the clock pulse at the SCL eighth bit of data transfer to "L".

When the next 1-byte transfer is left in the receive state after transmission of the ACK signal from the receive side, the receive side releases SDA at fall of the SCL ninth clock.

In the I<sup>2</sup>C bus, there is no CE signal. Instead, 7-bit slave address is assigned to each device and the first byte of transfer is assigned to the command (R/W) representing the 7-bit slave address and subsequent transfer direction.

Note that only WRITE is valid in LV5207LP.

The 7-bit address is transferred sequentially from MSB and the eight bit is "L" representing WRITE.

In LV5207LP, the slave address is specified as (1110101).

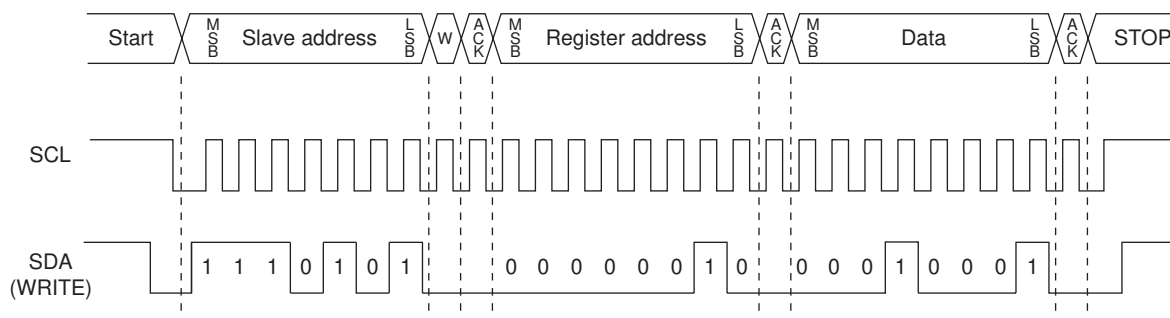

# LV5207LP

## Serial modes setting

Address								Data							
0	0	0	0	0	0	0	0	D7	D6	D5	D4	D3	D2	D1	0

D1	BSW	BLED output setting
0	OFF	* Default
1	ON	

D2	GSW	GLLED output setting
0	OFF	* Default
1	ON	

D3	RSW	RLED output setting
0	OFF	* Default
1	ON	

D4	CKSW	Charge pump clock switchover
0	OFF	* Default
1	ON	Use divided frequency (1/2)

D5	C10	Charge pump force ×1 mode
0	OFF	* Default
1	ON	

D6	SCTEN	SCTL signal enable
0	SCTL enabled	* Default
1	SCTL disabled	

D7	CPSW	Charge pump ON/OFF setting
0	OFF	* Default
1	ON	

# LV5207LP

Address								Data							
0	0	0	0	0	0	0	1	D7	D6	0	D4	D3	D2	D1	D0

D4	D3	D2	D1	D0	Current value (mA)
0	0	0	0	0	0.8
0	0	0	0	1	1.4
0	0	0	1	0	2.0
0	0	0	1	1	2.6
0	0	1	0	0	3.2
0	0	1	0	1	3.8
0	0	1	1	0	4.4
0	0	1	1	1	5.0
0	1	0	0	0	5.6
0	1	0	0	1	6.2
0	1	0	1	0	6.8
0	1	0	1	1	7.4
0	1	1	0	0	8.0
0	1	1	0	1	8.6
0	1	1	1	0	9.2
0	1	1	1	1	9.8
1	0	0	0	0	10.4
1	0	0	0	1	11.0
1	0	0	1	0	11.6
1	0	0	1	1	12.2
1	0	1	0	0	12.8
1	0	1	0	1	13.4
1	0	1	1	0	14.0
1	0	1	1	1	14.6
1	1	0	0	0	15.2
1	1	0	0	1	15.8
1	1	0	1	0	16.4
1	1	0	1	1	17.0
1	1	1	0	0	17.6
1	1	1	0	1	18.2
1	1	1	1	0	18.8
1	1	1	1	1	19.4

Main LED current value setting  
\* Default

D6	MLED4
0	OFF
1	ON

MAIN LED4 output setting  
\* Default

D7	MSW
0	OFF
1	ON

MAIN LED output setting  
\* Default

# LV5207LP

Address								Data							
0	0	0	0	0	0	1	0	0	0	0	D4	D3	D2	D1	D0

D4	D3	D2	D1	D0	Current Value (mA)
0	0	0	0	0	0.8
0	0	0	0	1	1.4
0	0	0	1	0	2.0
0	0	0	1	1	2.6
0	0	1	0	0	3.2
0	0	1	0	1	3.8
0	0	1	1	0	4.4
0	0	1	1	1	5.0
0	1	0	0	0	5.6
0	1	0	0	1	6.2
0	1	0	1	0	6.8
0	1	0	1	1	7.4
0	1	1	0	0	8.0
0	1	1	0	1	8.6
0	1	1	1	0	9.2
0	1	1	1	1	9.8
1	0	0	0	0	10.4
1	0	0	0	1	11.0
1	0	0	1	0	11.6
1	0	0	1	1	12.2
1	0	1	0	0	12.8
1	0	1	0	1	13.4
1	0	1	1	0	14.0
1	0	1	1	1	14.6
1	1	0	0	0	15.2
1	1	0	0	1	15.8
1	1	0	1	0	16.4
1	1	0	1	1	17.0
1	1	1	0	0	17.6
1	1	1	0	1	18.2
1	1	1	1	0	18.8
1	1	1	1	1	19.4

RLED current value setting  
\* Default

# LV5207LP

Address								Data							
0	0	0	0	0	0	1	1	0	0	0	D4	D3	D2	D1	D0

D4	D3	D2	D1	D0	Current Value (mA)
0	0	0	0	0	0.8
0	0	0	0	1	1.4
0	0	0	1	0	2.0
0	0	0	1	1	2.6
0	0	1	0	0	3.2
0	0	1	0	1	3.8
0	0	1	1	0	4.4
0	0	1	1	1	5.0
0	1	0	0	0	5.6
0	1	0	0	1	6.2
0	1	0	1	0	6.8
0	1	0	1	1	7.4
0	1	1	0	0	8.0
0	1	1	0	1	8.6
0	1	1	1	0	9.2
0	1	1	1	1	9.8
1	0	0	0	0	10.4
1	0	0	0	1	11.0
1	0	0	1	0	11.6
1	0	0	1	1	12.2
1	0	1	0	0	12.8
1	0	1	0	1	13.4
1	0	1	1	0	14.0
1	0	1	1	1	14.6
1	1	0	0	0	15.2
1	1	0	0	1	15.8
1	1	0	1	0	16.4
1	1	0	1	1	17.0
1	1	1	0	0	17.6
1	1	1	0	1	18.2
1	1	1	1	0	18.8
1	1	1	1	1	19.4

GLED current value setting  
\* Default

# LV5207LP

Address								Data							
0	0	0	0	0	1	0	0	0	0	0	D4	D3	D2	D1	D0

D4	D3	D2	D1	D0	Current Value (mA)
0	0	0	0	0	0.8
0	0	0	0	1	1.4
0	0	0	1	0	2.0
0	0	0	1	1	2.6
0	0	1	0	0	3.2
0	0	1	0	1	3.8
0	0	1	1	0	4.4
0	0	1	1	1	5.0
0	1	0	0	0	5.6
0	1	0	0	1	6.2
0	1	0	1	0	6.8
0	1	0	1	1	7.4
0	1	1	0	0	8.0
0	1	1	0	1	8.6
0	1	1	1	0	9.2
0	1	1	1	1	9.8
1	0	0	0	0	10.4
1	0	0	0	1	11.0
1	0	0	1	0	11.6
1	0	0	1	1	12.2
1	0	1	0	0	12.8
1	0	1	0	1	13.4
1	0	1	1	0	14.0
1	0	1	1	1	14.6
1	1	0	0	0	15.2
1	1	0	0	1	15.8
1	1	0	1	0	16.4
1	1	0	1	1	17.0
1	1	1	0	0	17.6
1	1	1	0	1	18.2
1	1	1	1	0	18.8
1	1	1	1	1	19.4

BLED current value setting  
\* Default

# LV5207LP

## Serial map

Address								Data							
A7	A6	A5	A4	A3	A2	A1	A0	D7	D6	D5	D4	D3	D2	D1	D0
0	0	0	0	0	0	0	0	CPSW	SCTEN	C10	CKSW	RSW	GSW	BSW	x
								0	0	0	0	0	0	0	0
0	0	0	0	0	0	0	1	MSW	MLED4	x	MC [4 : 0]				
								0	0	0	0	0	0	0	0
0	0	0	0	0	0	1	0	x	x	x	RC [4 : 0]				
								0	0	0	0	0	0	0	0
0	0	0	0	0	0	1	1	x	x	x	GC [4 : 0]				
								0	0	0	0	0	0	0	0
0	0	0	0	0	1	0	0	x	x	x	BC [4 : 0]				
								0	0	0	0	0	0	0	0

Table upper stage : Register name    Table lower stage : Default value

ON Semiconductor and the ON logo are registered trademarks of Semiconductor Components Industries, LLC (SCILLC). SCILLC owns the rights to a number of patents, trademarks, copyrights, trade secrets, and other intellectual property. A listing of SCILLC's product/patent coverage may be accessed at [www.onsemi.com/site/pdf/Patent-Marking.pdf](http://www.onsemi.com/site/pdf/Patent-Marking.pdf). SCILLC reserves the right to make changes without further notice to any products herein. SCILLC makes no warranty, representation or guarantee regarding the suitability of its products for any particular purpose, nor does SCILLC assume any liability arising out of the application or use of any product or circuit, and specifically disclaims any and all liability, including without limitation special, consequential or incidental damages. "Typical" parameters which may be provided in SCILLC data sheets and/or specifications can and do vary in different applications and actual performance may vary over time. All operating parameters, including "Typicals" must be validated for each customer application by customer's technical experts. SCILLC does not convey any license under its patent rights nor the rights of others. SCILLC products are not designed, intended, or authorized for use as components in systems intended for surgical implant into the body, or other applications intended to support or sustain life, or for any other application in which the failure of the SCILLC product could create a situation where personal injury or death may occur. Should Buyer purchase or use SCILLC products for any such unintended or unauthorized application, Buyer shall indemnify and hold SCILLC and its officers, employees, subsidiaries, affiliates, and distributors harmless against all claims, costs, damages, and expenses, and reasonable attorney fees arising out of, directly or indirectly, any claim of personal injury or death associated with such unintended or unauthorized use, even if such claim alleges that SCILLC was negligent regarding the design or manufacture of the part. SCILLC is an Equal Opportunity/Affirmative Action Employer. This literature is subject to all applicable copyright laws and is not for resale in any manner.