



Chipsmall Limited consists of a professional team with an average of over 10 year of expertise in the distribution of electronic components. Based in Hongkong, we have already established firm and mutual-benefit business relationships with customers from,Europe,America and south Asia,supplying obsolete and hard-to-find components to meet their specific needs.

With the principle of “Quality Parts,Customers Priority,Honest Operation,and Considerate Service”,our business mainly focus on the distribution of electronic components. Line cards we deal with include Microchip,ALPS,ROHM,Xilinx,Pulse,ON,Everlight and Freescale. Main products comprise IC,Modules,Potentiometer,IC Socket,Relay,Connector.Our parts cover such applications as commercial,industrial, and automotives areas.

We are looking forward to setting up business relationship with you and hope to provide you with the best service and solution. Let us make a better world for our industry!



## Contact us

Tel: +86-755-8981 8866 Fax: +86-755-8427 6832

Email & Skype: info@chipsmall.com Web: www.chipsmall.com

Address: A1208, Overseas Decoration Building, #122 Zhenhua RD., Futian, Shenzhen, China





**ON Semiconductor®**

<http://onsemi.com>

# LV52204MU

Bi-CMOS IC

## LED Boost Driver with PWM and 1-Wire Dimming

### Overview

The LV52204MU is a high voltage boost driver for LED drive. LED current is set by the external resistor R1 and LED dimming can be done by changing FB voltage with PWM or 1-Wire.

### Features

- Operating Voltage from 2.7V to 5.5V
- Integrated 40V MOSFET
- 1-Wire 32 level digital and PWM dimming
- 600kHz Switching Frequency

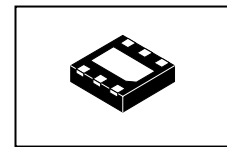

UDFN6 2 × 2 , 0.65P

### Typical Applications

- LED Display Backlight Control

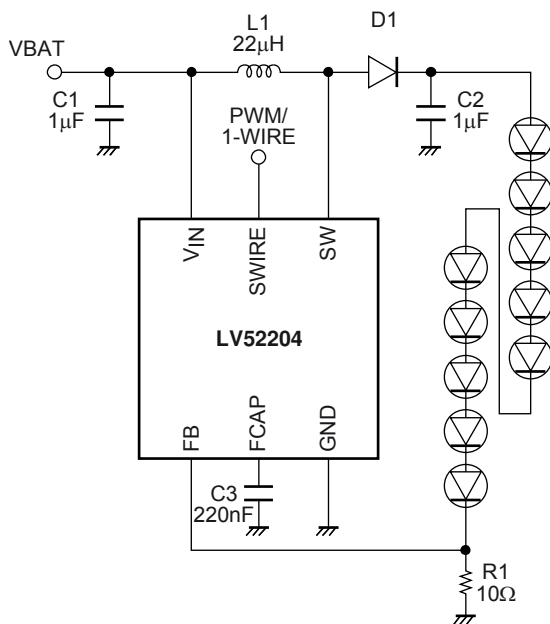

### ORDERING INFORMATION

See detailed ordering and shipping information on page 16 of this data sheet.

# LV52204MU

## Specifications

### Absolute Maximum Ratings at $T_a = 25^\circ\text{C}$

| Parameter                   | Symbol              | Conditions                  | Ratings     | Unit             |
|-----------------------------|---------------------|-----------------------------|-------------|------------------|
| Maximum supply voltage      | $V_{CC\text{ max}}$ | $V_{CC}$                    | 5.5         | V                |
| Maximum pin voltage1        | $V1\text{ max}$     | SW                          | 40          | V                |
| Maximum pin voltage2        | $V2\text{ max}$     | Other pin                   | 5.5         | V                |
| Allowable power dissipation | $Pd\text{ max}$     | $T_a = 25^\circ\text{C}^*1$ | 2.05        | W                |
| Operating temperature       | $T_{opr}$           |                             | -30 to +85  | $^\circ\text{C}$ |
| Storage temperature         | $T_{stg}$           |                             | -55 to +125 | $^\circ\text{C}$ |

\*1 Mounted on a specified board: 70mm×50mm×1.2mm (4 layer glass epoxy)

Caution 1) Absolute maximum ratings represent the values which cannot be exceeded for any length of time.

Caution 2) Even when the device is used within the range of absolute maximum ratings, as a result of continuous usage under high temperature, high current, high voltage, or drastic temperature change, the reliability of the IC may be degraded. Please contact us for the further details.

Stresses exceeding those listed in the Maximum Ratings table may damage the device. If any of these limits are exceeded, device functionality should not be assumed, damage may occur and reliability may be affected.

### Recommendation Operating Condition at $T_a = 25^\circ\text{C}$

| Parameter             | Symbol             | Conditions | Ratings     | Unit |
|-----------------------|--------------------|------------|-------------|------|
| Supply voltage range1 | $V_{CC\text{ op}}$ | $V_{CC}$   | 2.7 to 5.5  | V    |
| PWM frequency         | $F_{pwm}$          | PWM MODE   | 300 to 100k | Hz   |

Functional operation above the stresses listed in the Recommended Operating Ranges is not implied. Extended exposure to stresses beyond the Recommended Operating Ranges limits may affect device reliability.

### Electrical Characteristics Analog block at $T_a = 25^\circ\text{C}$ , $V_{CC} = 3.6\text{V}$ , unless otherwise specified

| Parameter                               | Symbol     | Conditions                                       | Ratings |     |          | Unit             |
|---|------------|--|---------|-----|----------|------------------|
|   |            |  | min     | typ | max      |                  |
| Standby current dissipation             | $I_{CC1}$  | SHUTDOWN   |         | 0   | 5        | $\mu\text{A}$    |
| DC/DC current dissipation               | $I_{CC2}$  | $V_{OUT} = 30\text{V}$ , $I_{LED} = 20\text{mA}$ |         |     | 1        | mA               |
| FB voltage                              | $V_{fb}$   | PWM duty 100%                                    | 0.19    | 0.2 | 0.21     | V                |
| FB pin leak current                     | $I_{fb}$   |  |         |     | 1        | $\mu\text{A}$    |
| OVP voltage                             | $V_{ovp}$  | SW   | 37      | 38  | 39       | V                |
| SWOUT ON resistance                     | $R_{on}$   | $I_L = 100\text{mA}$                             |         | 700 |          | $\text{m}\Omega$ |
| NMOS switch current limit               | $I_{LIM}$  | $V_{fb} = 200\text{mV}$                          |         | 0.7 |          | A                |
| OSC frequency                           | $F_{osc}$  |  |         | 600 |          | kHz              |
| High level input voltage                | $V_{INH}$  | SWIRE  | 1.5     |     | $V_{CC}$ | V                |
| Low level input voltage                 | $V_{INL}$  | SWIRE  | 0       |     | 0.4      | V                |
| Under voltage lockout                   | $V_{uvlo}$ | $V_{IN}$ falling                                 |         | 2.2 |          | V                |
| SWIRE output voltage<br>for Acknowledge | $V_{ack}$  | $R_{pullup} = 15\text{k}\Omega$                  |         |     | 0.4      | V                |

Product parametric performance is indicated in the Electrical Characteristics for the listed test conditions, unless otherwise noted. Product performance may not be indicated by the Electrical Characteristics if operated under different conditions.



# LV52204MU

## Pin Connections

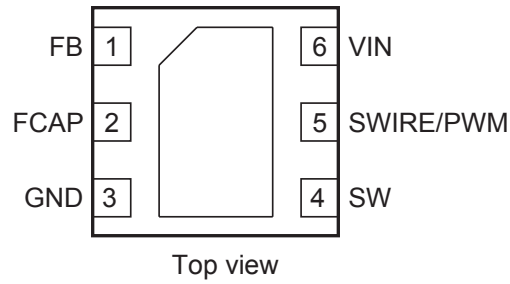

## Pin Function

| PIN # | Pin Name        | Description   |
|-------|-----------------|---|
| 1     | FB              | Feedback pin.   |
| 2     | FCAP            | Filtering capacitor terminal for PWM mode.                  |
| 3     | GND             | Ground  |
| 4     | SW              | Switch pin. Drain of the internal power FET.                |
| 5     | SWIRE           | 1-wire dimming control and PWM dimming input (active High). |
| 6     | V <sub>CC</sub> | Supply voltage.   |
|       | Expose-pad      | Connect to GND on PCB.                                      |

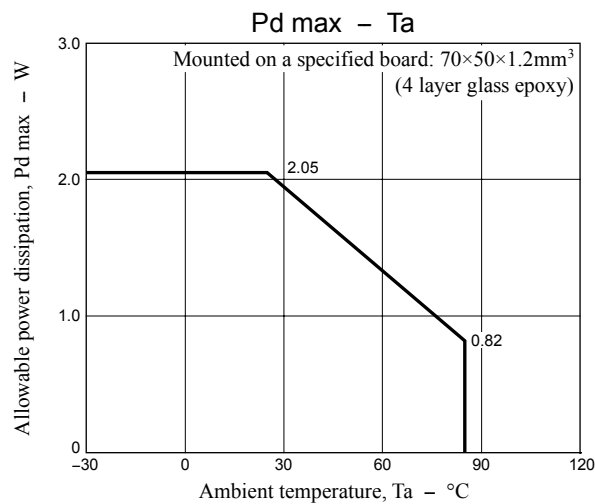

## LED Current Setting

LED current is set by an external resistor connected between the FB pin and ground.

$$I_{LED} = V_{FB}/R_{FB}.$$

The  $V_{FB}$  can be controlled by two dimming modes, PWM Mode or Digital Mode. In PWM mode, PWM input is converted into a near DC current by the internal resistor R that was equivalent to  $60k\Omega (\pm 10\%)$  and the external capacitor  $C_{FCAP}$  as a low pass filter with a cut-off frequency  $f_c = 1/2\pi R_{FCAP}$ . The  $V_{FB}$  can be adjusted by altering the duty cycle of the PWM signal (See Fig.1).

$$V_{FB} = 200 \text{ (mV)} \times \text{PWM Duty (\%)}$$

On the other hand,  $V_{FB}$  can be selected one from among 32 steps in Digital Mode (See Fig.2).

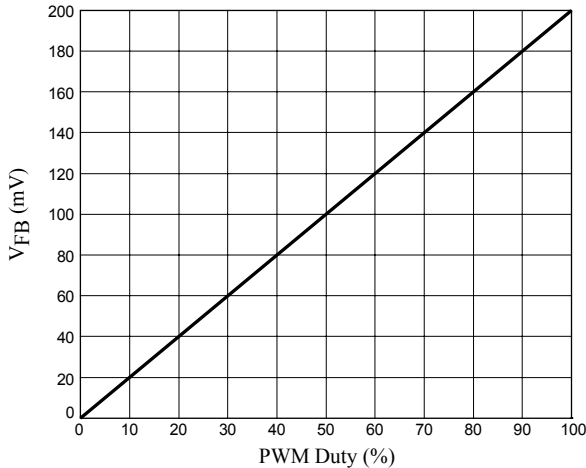

Fig1.  $V_{FB}$  vs. PWM Duty (PWM mode)

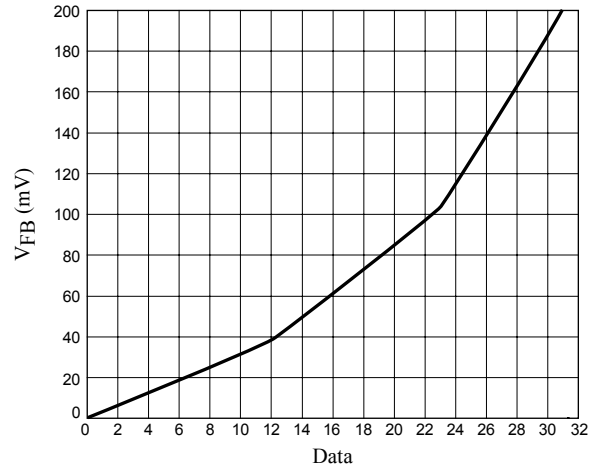

Fig2.  $V_{FB}$  vs. Data Register Value (Digital mode)

## Dimming Mode Selection

Dimming Mode is selected by a specific pattern of the SWIRE within  $T_{sel}$  (1ms) from the startup of the device every time. In order to startup the device, the SWIRE must keep high for longer than  $T_{on}$ .

### PWM Mode

The dimming mode is set to PWM mode when it is not recognized as a digital mode within  $T_{sel}$ . To enter Digital Mode, the SWIRE is required keeping in low state for  $T_{w1}$  (See Fig.4). If the PWM frequency is used faster than 6.6kHz, the dimming mode is set to PWM mode only. But slower than 6.6kHz, it is necessary to avoid entering the digital mode condition, such as SWIRE keeps high for longer than  $T_{sel}$ . PWM is enabled after  $T_{del}$  from  $T_{sel}$ .

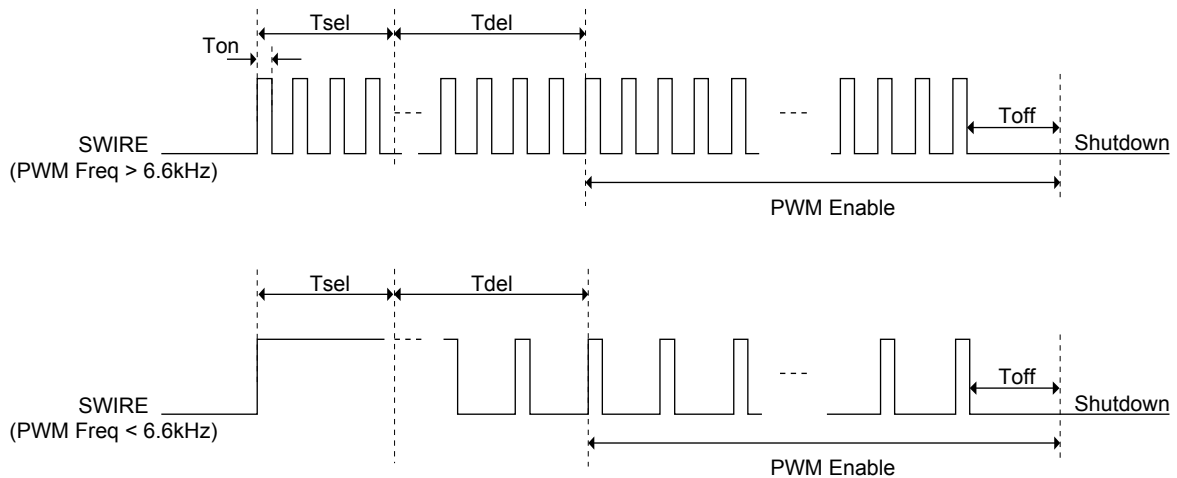

Fig3. SWIRE Timing Diagram in PWM mode



# LV52204MU

## Digital Mode

To enter Digital Mode, SWIRE should be taken high for more than  $T_{w0}$  (100 $\mu$ s) from the first rising edge and keep low state for  $T_{w1}$ (260 $\mu$ s) before  $T_{sel}$ (1ms).

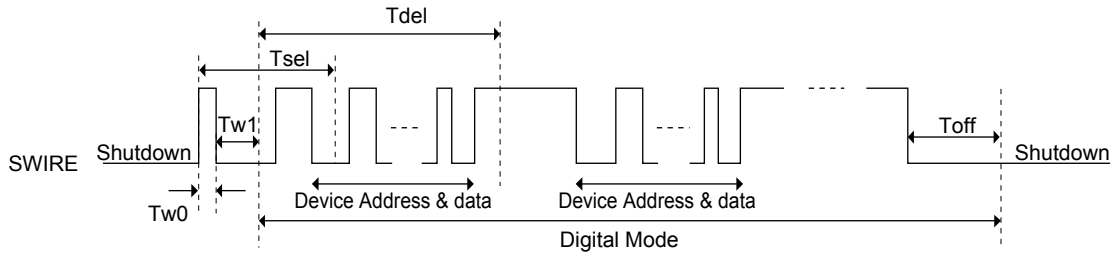

*Fig4. SWIRE Timing Diagram in Digital mode*

It is required sending the device address byte and the data byte to select  $V_{FB}$ . The bit detection is determined by the ratio of  $T_h$  and  $T_l$  (See Fig6). The start condition for the bit transmission required SWIRE high for at least  $T_{start}$ . The end condition is required SWIRE low for at least  $T_{end}$ . When data is not being transferred, SWIRE is set in the “H” state. These registers are initialized with POR (Power On Reset).

In the LV52204MU, the device address (DA7 to DA0) is specified as “01110010”. D7 is setting for the acknowledge response. If the device address and the data byte are transferred on  $D7 = 1$ , the ACK signal is sent from the receive side to the send side. The acknowledge signal is issued when SWIRE on the send side is released and SWIRE on the receive side is set to low state. D6 and D5 need to send 0. D4 to D0 allow to changing the FB voltage.

|                | Register | BIT | Description |
|----------------|----------|-----|-------------|
| Device Address | DA7      | 7   | 0           |
|                | DA6      | 6   | 1           |
|                | DA5      | 5   | 1           |
|                | DA4      | 4   | 1           |
|                | DA3      | 3   | 0           |
|                | DA2      | 2   | 0           |
|                | DA1      | 1   | 1           |
|                | DA0      | 0   | 0           |

*Table1. Device Address Description*

|      | Register | BIT | Description   |
|------|----------|-----|---|
| Data | D7       | 7   | 0 = Acknowledge disabled<br>1 = Acknowledge enabled |
|      | D6       | 6   | 0   |
|      | D5       | 5   | 0   |
|      | D4       | 4   | Data bit 4  |
|      | D3       | 3   | Data bit 3  |
|      | D2       | 2   | Data bit 2  |
|      | D1       | 1   | Data bit 1  |
|      | D0       | 0   | Data bit 0  |

*Table2. Data Description*

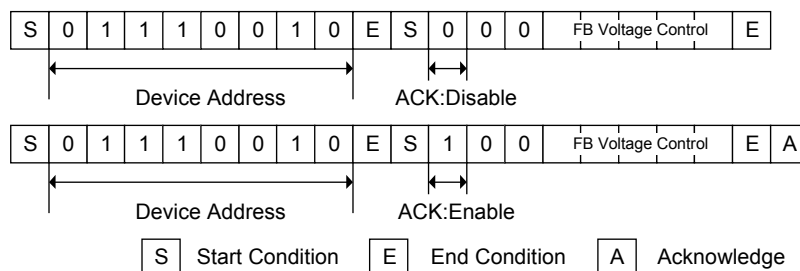

*Fig5. Example of writing data*

# LV52204MU

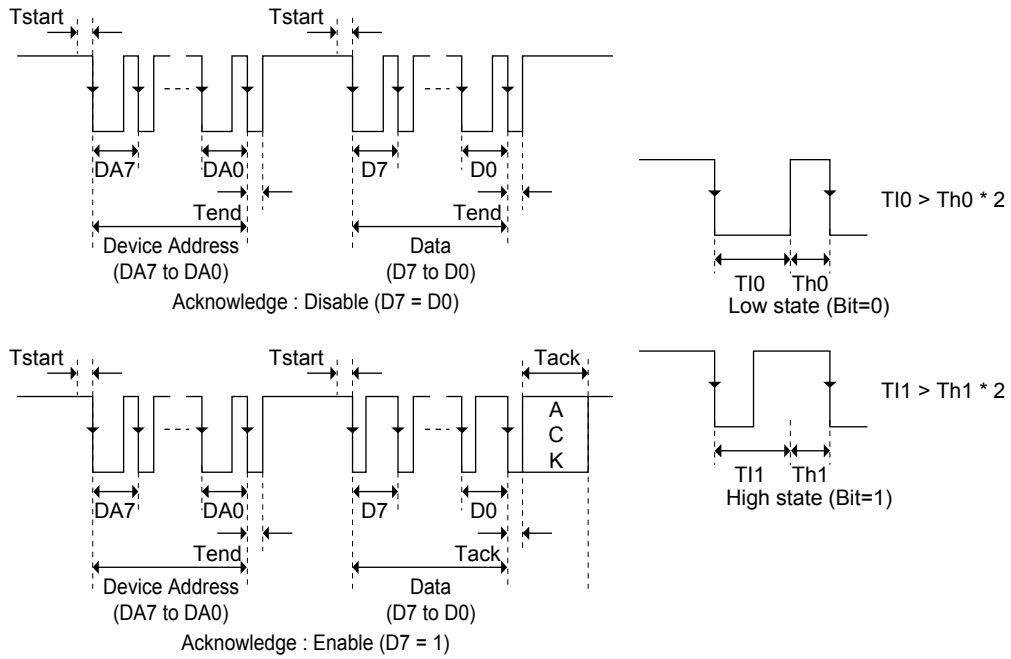

*Fig6.Bit detection Diagram*

|    | D7  | D6 | D5 | D4 | D3 | D2 | D1 | D0 | FB voltage (mV) |
|----|-----|----|----|----|----|----|----|----|-----------------|
| 0  | 1/0 | 0  | 0  | 0  | 0  | 0  | 0  | 0  | 0               |
| 1  | 1/0 | 0  | 0  | 0  | 0  | 0  | 0  | 1  | 5               |
| 2  | 1/0 | 0  | 0  | 0  | 0  | 0  | 1  | 0  | 8               |
| 3  | 1/0 | 0  | 0  | 0  | 0  | 0  | 1  | 1  | 11              |
| 4  | 1/0 | 0  | 0  | 0  | 0  | 1  | 0  | 0  | 14              |
| 5  | 1/0 | 0  | 0  | 0  | 0  | 1  | 0  | 1  | 17              |
| 6  | 1/0 | 0  | 0  | 0  | 0  | 1  | 1  | 0  | 20              |
| 7  | 1/0 | 0  | 0  | 0  | 0  | 1  | 1  | 1  | 23              |
| 8  | 1/0 | 0  | 0  | 0  | 1  | 0  | 0  | 0  | 26              |
| 9  | 1/0 | 0  | 0  | 0  | 1  | 0  | 0  | 1  | 29              |
| 10 | 1/0 | 0  | 0  | 0  | 1  | 0  | 1  | 0  | 32              |
| 11 | 1/0 | 0  | 0  | 0  | 1  | 0  | 1  | 1  | 35              |
| 12 | 1/0 | 0  | 0  | 0  | 1  | 1  | 0  | 0  | 38              |
| 13 | 1/0 | 0  | 0  | 0  | 1  | 1  | 0  | 1  | 44              |
| 14 | 1/0 | 0  | 0  | 0  | 1  | 1  | 1  | 0  | 50              |
| 15 | 1/0 | 0  | 0  | 0  | 1  | 1  | 1  | 1  | 56              |
| 16 | 1/0 | 0  | 0  | 1  | 0  | 0  | 0  | 0  | 62              |
| 17 | 1/0 | 0  | 0  | 1  | 0  | 0  | 0  | 1  | 68              |
| 18 | 1/0 | 0  | 0  | 1  | 0  | 0  | 1  | 0  | 74              |
| 19 | 1/0 | 0  | 0  | 1  | 0  | 0  | 1  | 1  | 80              |
| 20 | 1/0 | 0  | 0  | 1  | 0  | 1  | 0  | 0  | 86              |
| 21 | 1/0 | 0  | 0  | 1  | 0  | 1  | 0  | 1  | 92              |
| 22 | 1/0 | 0  | 0  | 1  | 0  | 1  | 1  | 0  | 98              |
| 23 | 1/0 | 0  | 0  | 1  | 0  | 1  | 1  | 1  | 104             |
| 24 | 1/0 | 0  | 0  | 1  | 1  | 0  | 0  | 0  | 116             |
| 25 | 1/0 | 0  | 0  | 1  | 1  | 0  | 0  | 1  | 128             |
| 26 | 1/0 | 0  | 0  | 1  | 1  | 0  | 1  | 0  | 140             |
| 27 | 1/0 | 0  | 0  | 1  | 1  | 0  | 1  | 1  | 152             |
| 28 | 1/0 | 0  | 0  | 1  | 1  | 1  | 0  | 0  | 164             |
| 29 | 1/0 | 0  | 0  | 1  | 1  | 1  | 0  | 1  | 176             |
| 30 | 1/0 | 0  | 0  | 1  | 1  | 1  | 1  | 0  | 188             |
| 31 | 1/0 | 0  | 0  | 1  | 1  | 1  | 1  | 1  | *200            |

(\*Default)

*Table3. Data Register vs. FB Voltage*



**Start up and Shutdown**

The device becomes enabled when SWIRE is initially taken high. The dimming mode is determined within  $T_{sel}$  and the boost converter start up after  $T_{del}$ . To place the device into shutdown mode, the SWIRE must be held low for  $T_{off}$ .

PWM MODE

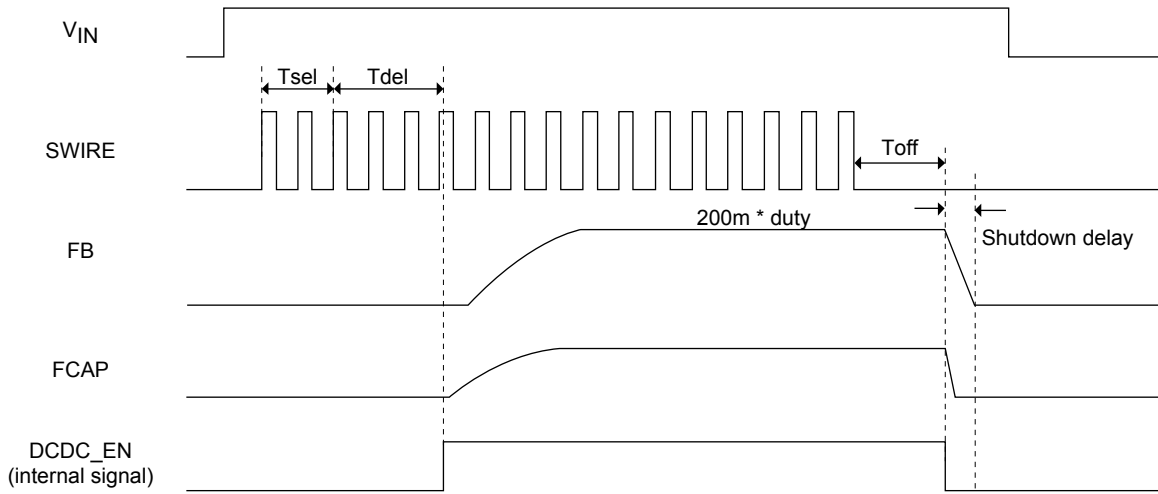

Digital MODE

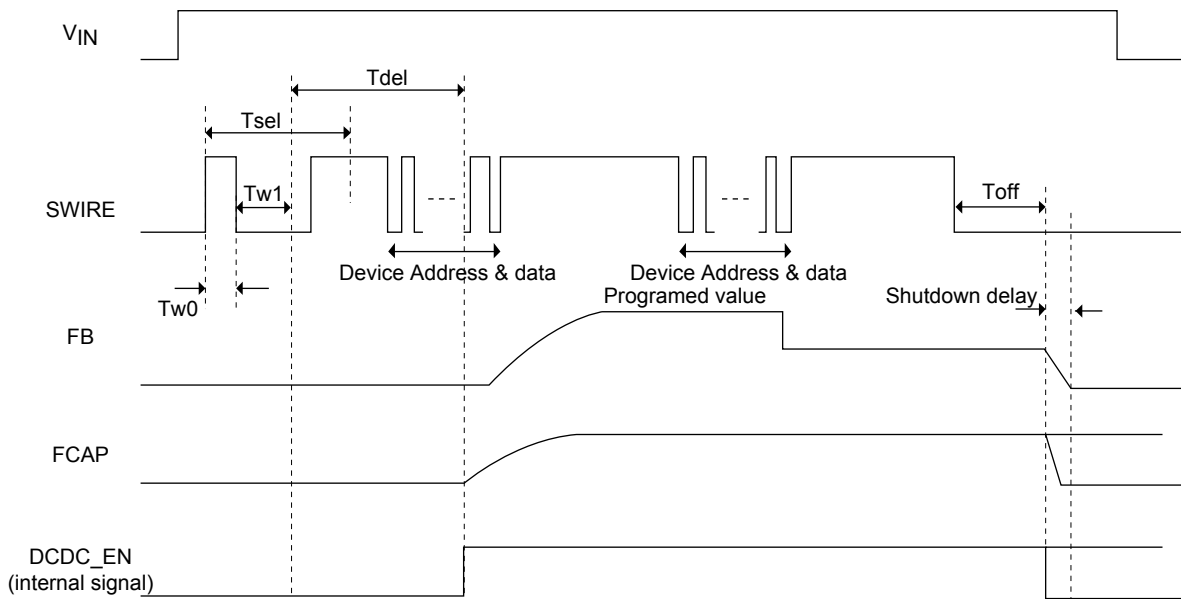

Fig7. Start up and shutdown diagram

# LV52204MU

## Open LED Protection

If SW terminal voltage exceeds a threshold  $V_{ovp}$  (38V typ) for 8 cycles, boost converter enters shutdown mode. In order to restart the IC, SWIRE signal is required again.

## Over Current Protection

Current limit value for built-in power MOS is around 0.7A. The power MOS is turned off for each switching cycle when peak current through it exceeds the limit value.

## Under Voltage Lock Out (UVLO)

UVLO operation works when  $V_{IN}$  terminal voltage is below 2.2V.

## Thermal Shutdown

When chip temperature is too high, boost converter is stopped.

## Application Circuit Diagram

### 10LEDs

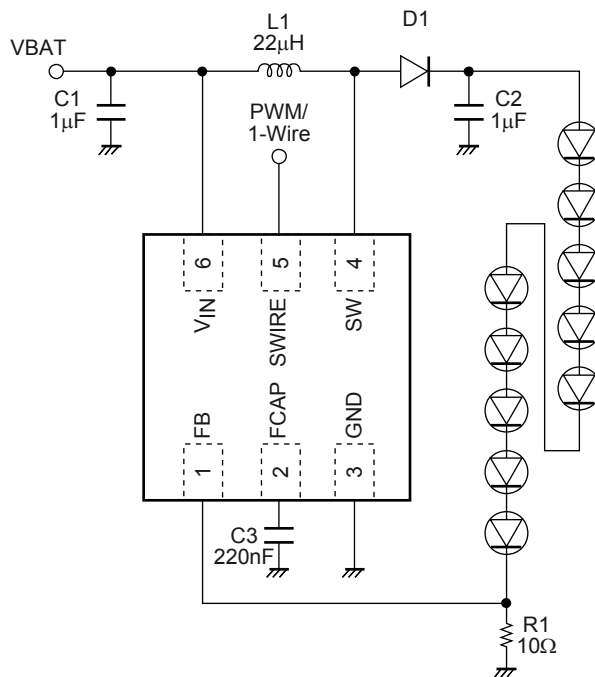

L1: VLS3012T-220M49 (TDK), VLF504015MT-220M (TDK)

D1: MBR0540T1 (ON semi), NSR05F40 (ONsemi)

C2: GRM21BR71H105K (Murata), C1608X5R1H105K (TDK)

# LV52204MU

## 6LEDs

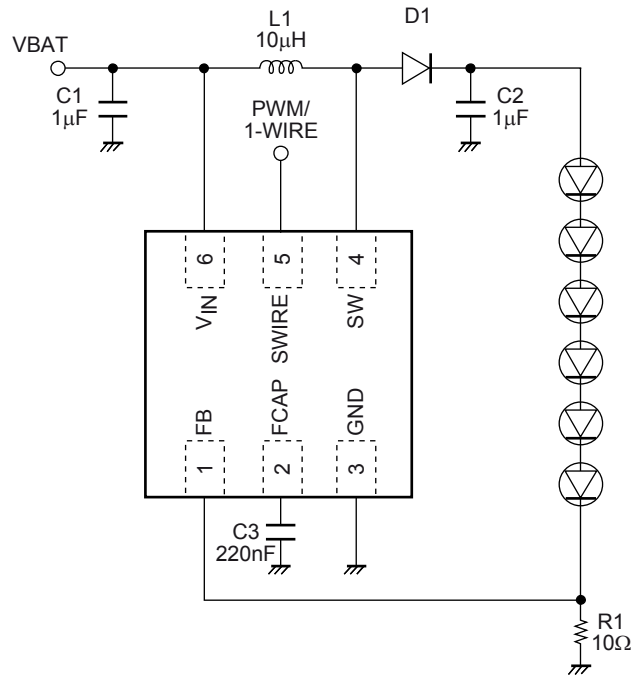

- L1: VLS3012T-100M72 (TDK), VLF302512M-100M (TDK)  
D1: MBR0540T1 (ON semi), NSR05F40 (ONsemi)  
C2: GRM21BR71H105K (Murata), C1608X5R1H105K (TDK)

# LV52204MU

Typical Characteristics ( $V_{IN} = 3.6V$ ,  $L = 22\mu H$ ,  $T = 25^\circ C$ , unless otherwise specified)

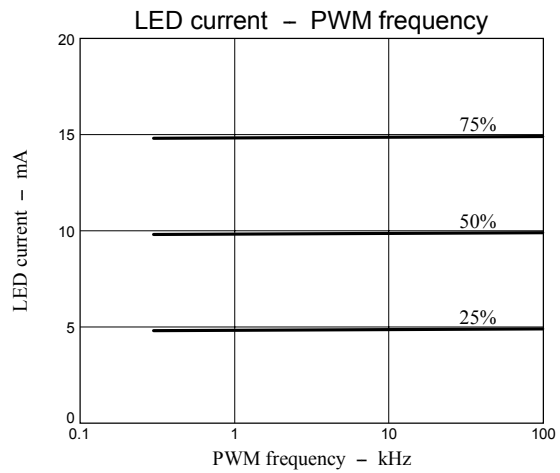
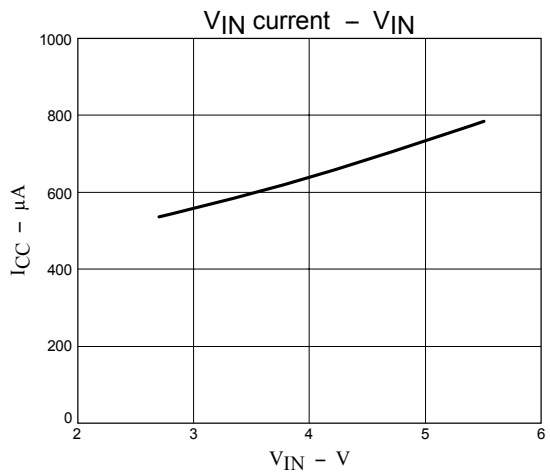
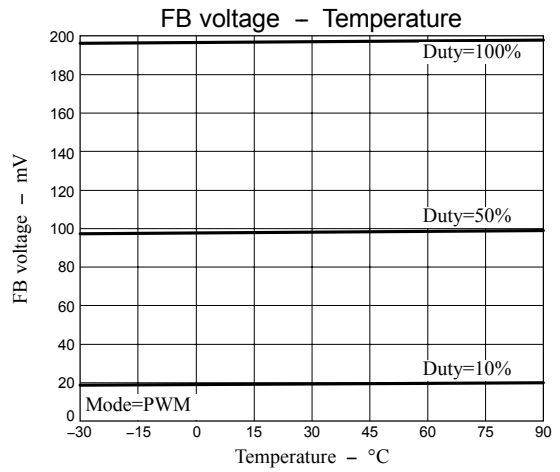
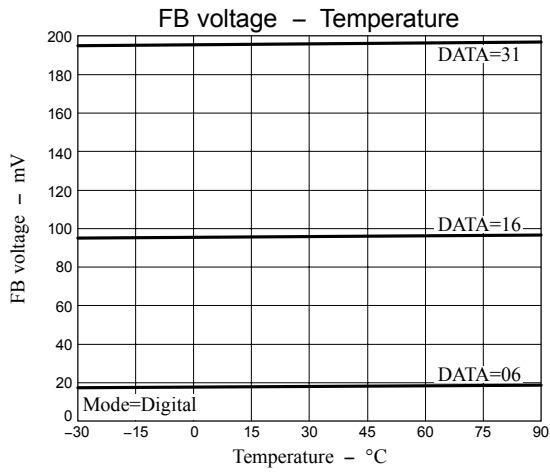
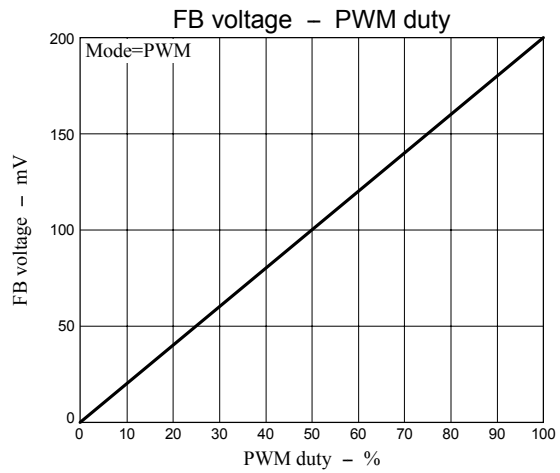
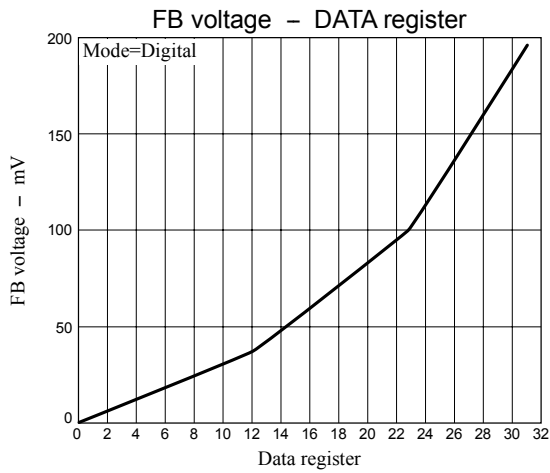
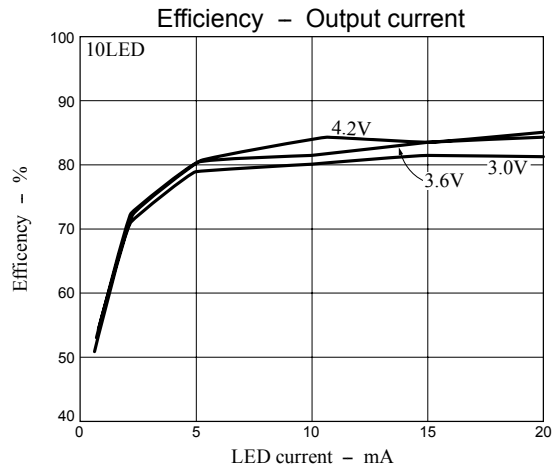
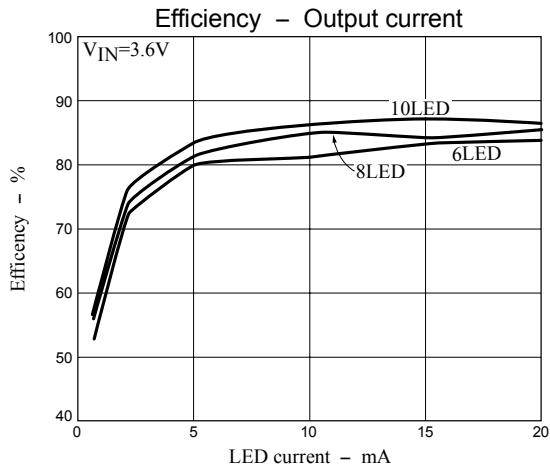

# LV52204MU

## PACKAGE DIMENSIONS

UDFN6 2x2, 0.65P  
CASE 517AB  
ISSUE C

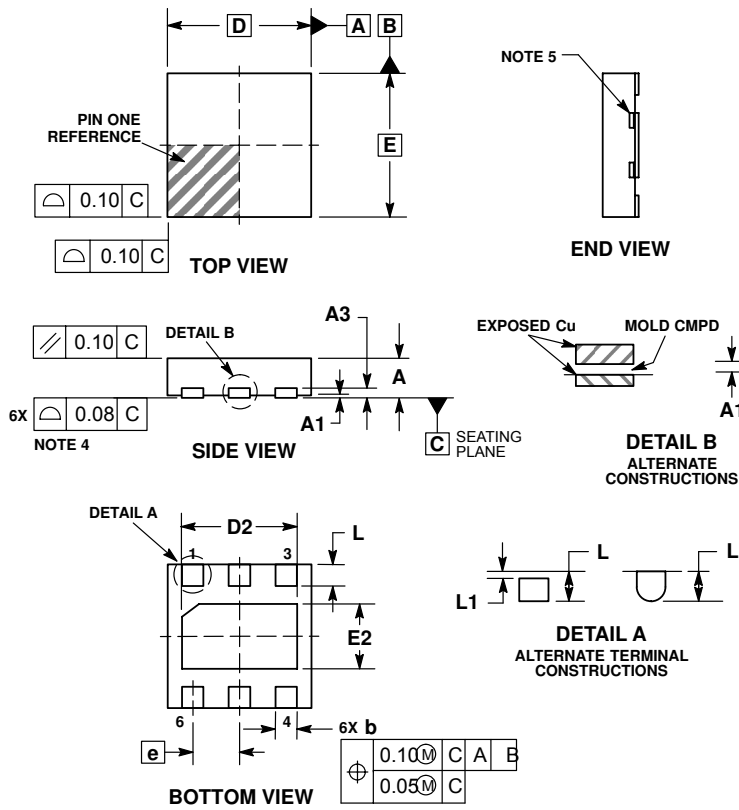

- NOTES:
1. DIMENSIONING AND TOLERANCING PER ASME Y14.5M, 1994.
  2. CONTROLLING DIMENSION: MILLIMETERS.
  3. DIMENSION b APPLIES TO PLATED TERMINAL AND IS MEASURED BETWEEN 0.15 AND 0.25MM FROM THE TERMINAL TIP.
  4. COPLANARITY APPLIES TO THE EXPOSED PAD AS WELL AS THE TERMINALS.
  5. TIE BARS MAY BE VISIBLE IN THIS VIEW AND ARE CONNECTED TO THE THERMAL PAD.

| DIM | MILLIMETERS |      |
|-----|-------------|------|
|     | MIN         | MAX  |
| A   | 0.45        | 0.55 |
| A1  | 0.00        | 0.05 |
| A3  | 0.127 REF   |      |
| b   | 0.25        | 0.35 |
| D   | 2.00 BSC    |      |
| D2  | 1.50        | 1.70 |
| E   | 2.00 BSC    |      |
| E2  | 0.80        | 1.00 |
| e   | 0.65 BSC    |      |
| L   | 0.25        | 0.35 |
| L1  | ---         | 0.15 |

### GENERIC MARKING DIAGRAM\*



- XX = Specific Device Code
  - M = Date Code
  - = Pb-Free Package
- (Note: Microdot may be in either location)

\*This information is generic. Please refer to device data sheet for actual part marking. Pb-Free indicator, "G" or microdot "■", may or may not be present.

### RECOMMENDED SOLDERING FOOTPRINT\*

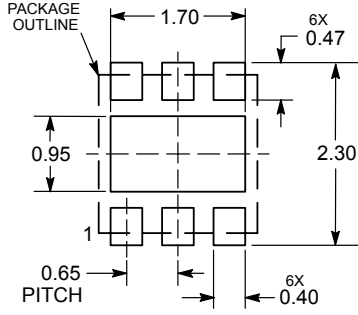

DIMENSIONS: MILLIMETERS

\*For additional information on our Pb-Free strategy and soldering details, please download the ON Semiconductor Soldering and Mounting Techniques Reference Manual, SOLDERRM/D.

LV52204MU is as follows.

### MARKING DIAGRAM

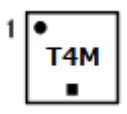

- T4 = Device Code
- M = Date Code
- = Pb-Free Package

1.EMBOSSED CARRIER TAPING

1 - 1 .Embossed carrier tape dimensions

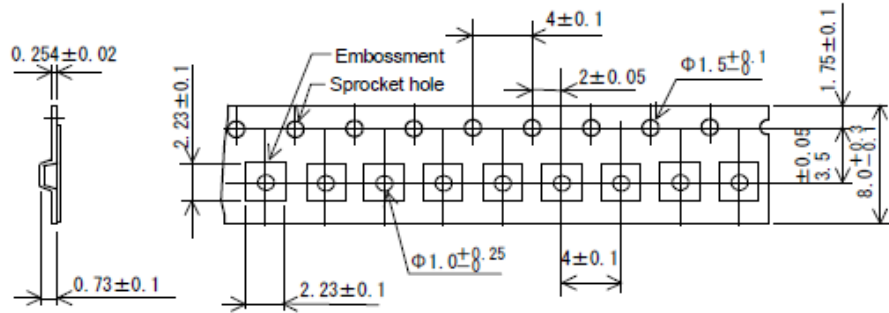

Unit Fmm

1 - 2 .Tape mounting direction

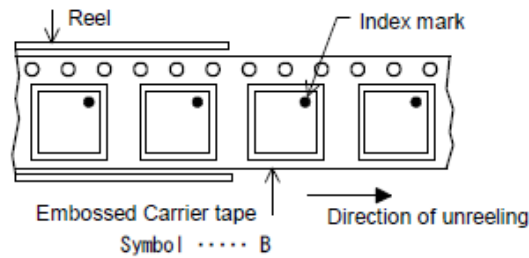

1 - 3 .Reel winding start and reel winding end

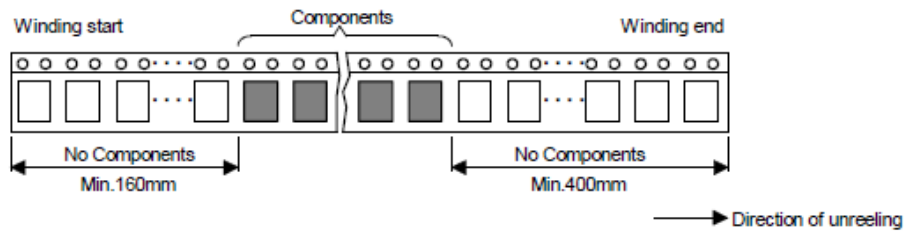

2 .TAPE STRENGTH

2 - 1 .Tensile strength of the carrier tape : Min.10N

2 - 2 .Peel strength of the top cover tape

( a )Peel angle : 165° to 180° relative to the tape adhesive surface

( b )Peel rate : 300mm / minute

( c )Peel of strength : 0.1N to 1.0N

3 .PARTS No. ON BAR CODE LABEL

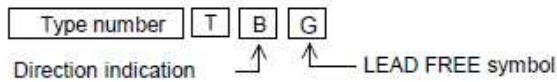

4 .REEL DIMENSIONS

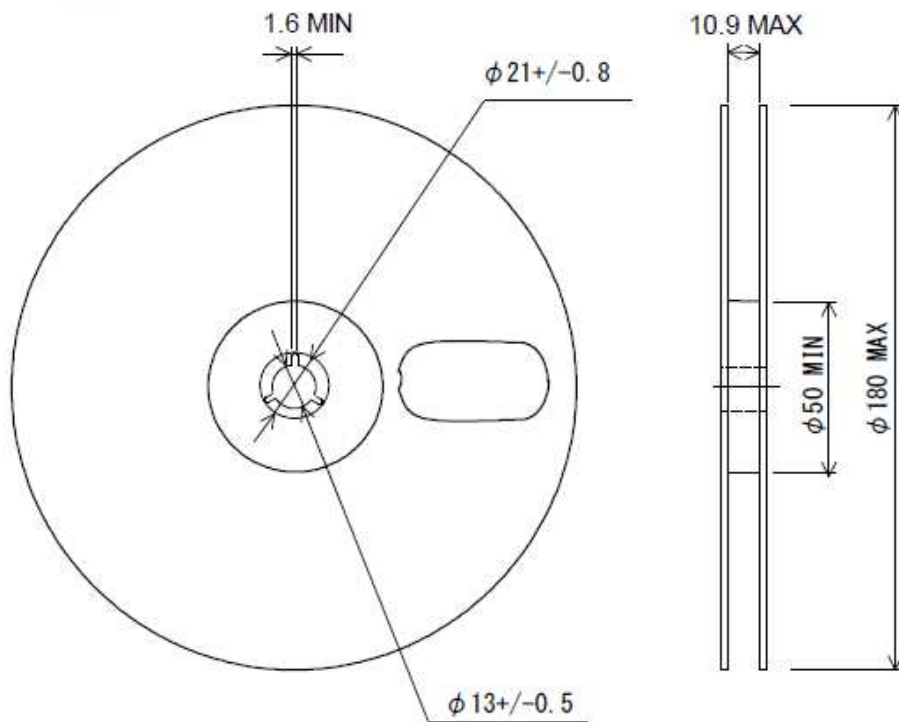

TYPE:P-RRM-08B  
UNIT:mm



Packing Specification of Embossed Carrier Taping

UDFN6(2.0\*2.0) 3,000 pcs/reel

| Carrier tape type number | Package code   | Maximum number of ICs contained (pcs.) |           | Packing form   |
|--------------------------|----------------|--|-----------|--|
|                          |                | Reel                                   | Inner box | Inner box. B50766P001                                  |
| N22986D001               | UDFN6(2.0*2.0) | 3,000                                  | 30,000    | 10 Reels contained<br>Dimensions:mm<br>190 × 136 × 186 |

**MPN Label**

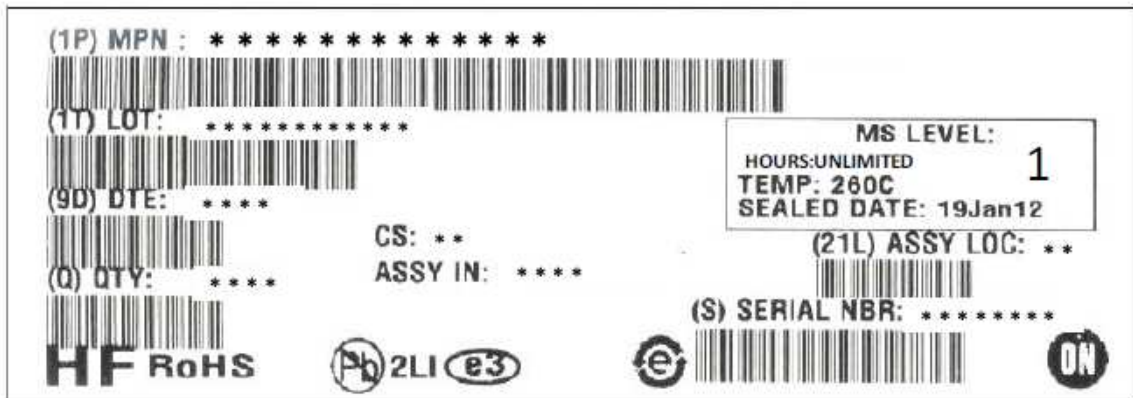

**Packing Method**

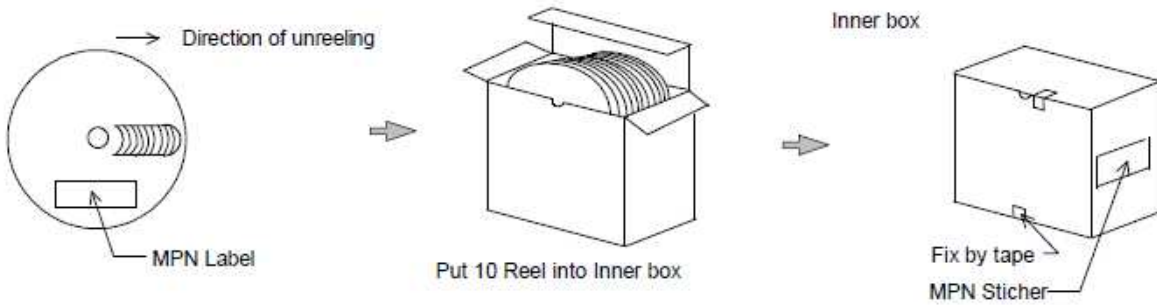

# LV52204MU

---

## ORDERING INFORMATION

| Device       | Package                    | Shipping (Qty / Packing) |
|--------------|----------------------------|--------------------------|
| LV52204MUTBG | UDFN6 (2x2)<br>( Pb-Free ) | 3000 / Tape & Reel       |

ON Semiconductor and the ON logo are registered trademarks of Semiconductor Components Industries, LLC (SCILLC). SCILLC owns the rights to a number of patents, trademarks, copyrights, trade secrets, and other intellectual property. A listing of SCILLC's product/patent coverage may be accessed at [www.onsemi.com/site/pdf/Patent-Marking.pdf](http://www.onsemi.com/site/pdf/Patent-Marking.pdf). SCILLC reserves the right to make changes without further notice to any products herein. SCILLC makes no warranty, representation or guarantee regarding the suitability of its products for any particular purpose, nor does SCILLC assume any liability arising out of the application or use of any product or circuit, and specifically disclaims any and all liability, including without limitation special, consequential or incidental damages. "Typical" parameters which may be provided in SCILLC data sheets and/or specifications can and do vary in different applications and actual performance may vary over time. All operating parameters, including "Typicals" must be validated for each customer application by customer's technical experts. SCILLC does not convey any license under its patent rights nor the rights of others. SCILLC products are not designed, intended, or authorized for use as components in systems intended for surgical implant into the body, or other applications intended to support or sustain life, or for any other application in which the failure of the SCILLC product could create a situation where personal injury or death may occur. Should Buyer purchase or use SCILLC products for any such unintended or unauthorized application, Buyer shall indemnify and hold SCILLC and its officers, employees, subsidiaries, affiliates, and distributors harmless against all claims, costs, damages, and expenses, and reasonable attorney fees arising out of, directly or indirectly, any claim of personal injury or death associated with such unintended or unauthorized use, even if such claim alleges that SCILLC was negligent regarding the design or manufacture of the part. SCILLC is an Equal Opportunity/Affirmative Action Employer. This literature is subject to all applicable copyright laws and is not for resale in any manner.