



Chipsmall Limited consists of a professional team with an average of over 10 year of expertise in the distribution of electronic components. Based in Hongkong, we have already established firm and mutual-benefit business relationships with customers from,Europe,America and south Asia,supplying obsolete and hard-to-find components to meet their specific needs.

With the principle of “Quality Parts,Customers Priority,Honest Operation,and Considerate Service”,our business mainly focus on the distribution of electronic components. Line cards we deal with include Microchip,ALPS,ROHM,Xilinx,Pulse,ON,Everlight and Freescale. Main products comprise IC,Modules,Potentiometer,IC Socket,Relay,Connector.Our parts cover such applications as commercial,industrial, and automotives areas.

We are looking forward to setting up business relationship with you and hope to provide you with the best service and solution. Let us make a better world for our industry!



Contact us

Tel: +86-755-8981 8866 Fax: +86-755-8427 6832

Email & Skype: info@chipsmall.com Web: www.chipsmall.com

Address: A1208, Overseas Decoration Building, #122 Zhenhua RD., Futian, Shenzhen, China





ON Semiconductor®

<http://onsemi.com>

LV52207XA

Bi-CMOS LSI

Dual channel LED Boost Driver with PWM and 1-Wire Dimming

Overview

The LV52207XA is a high voltage boost driver for LED drive with 2 channels adjustable constant current sources.

Function

- Operating Voltage from 2.7V to 5.5V
- Integrated 40V MOSFET
- 1-Wire 255 level digital and PWM dimming
- Supports CABC
- 1200kHz Switching Frequency
- 37.5V OVP Threshold

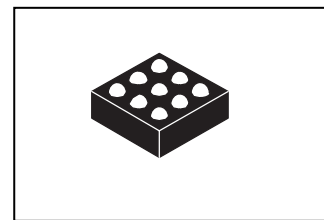

WLP9, 1.31x1.31, 0.4mm pitch
(1.31mm x 1.31mm, Amax=0.625 mm)

Typical Applications

LED Display Backlight Control

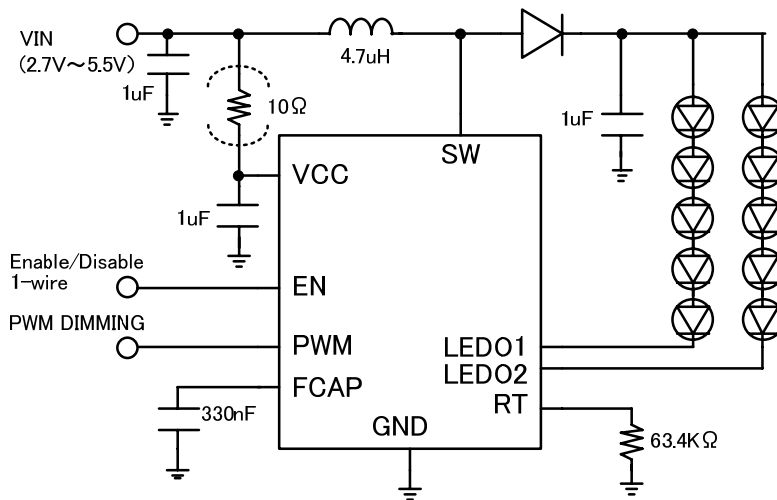

Fig1. 5x2 LED Application

ORDERING INFORMATION

See detailed ordering and shipping information on page 18 of this data sheet.

LV52207XA

Specifications

Absolute Maximum Ratings at Ta = 25°C

Parameter	Symbol	Conditions	Ratings	Unit
Maximum supply voltage	V _{CC} max	V _{CC}	6	V
Maximum Pin voltage1	V1 max	SW	40	V
Maximum Pin voltage2	V2 max	Other pin IOUT4, IOUT5, IOUT6	5.5	V
Allowable power dissipation didissipatioinm	Pd max	Ta=25°C *1	0.95	W
Operating temperature	Topr		-40 to +85	°C
Storage temperature	Tstg		-55 to +125	°C

*1 Mounted on a specified board: 70mm×70mm×1.6mm (4 layer glass epoxy)

Caution 1) Absolute maximum ratings represent the values which cannot be exceeded for any length of time.

Caution 2) Even when the device is used within the range of absolute maximum ratings, as a result of continuous usage under high temperature, high current, high voltage, or drastic temperature change, the reliability of the IC may be degraded. Please contact us for the further details.

Stresses exceeding those listed in the Maximum Ratings table may damage the device. If any of these limits are exceeded, device functionality should not be assumed, damage may occur and reliability may be affected.

Recommended Operating Conditions at Ta = 25°C

Parameter	Symbol	Conditions	Ratings	Unit
Supply voltage range1	V _{CC} op	V _{CC}	2.7 to 5.5	V
PWM frequency	Fpwm	PWM pin input signal	300 to 100k	Hz
MIN DUTY (PWM pin)	Dminpwm	PWM pin input signal	0.9%	

Functional operation above the stresses listed in the Recommended Operating Ranges is not implied. Extended exposure to stresses beyond the Recommended Operating Ranges limits may affect device reliability.

Electrical Characteristics Analog block

at Ta=25°C, V_{CC}=3.6V, RT resistor=63.4Kohm unless otherwise specified

Parameter	Symbol	Conditions	Ratings			Unit
			min	typ	max	
Standby current dissipation	I _{cc1}	EN=PWM=L		0	2	μA
DC/DC current dissipation1	I _{cc2}	Device enable, switching 1.2 MHz and no load		1.2	2	mA
FB Voltage	V _{fb}	LEDO1, 2=20mA		0.2		V
Output Current1	I _{o1}	LEDO1 LEDO2 LEDISET=20mA Duty=100%	19.6	20	20.4	mA
Output Current Matching1	I _{om1}	LEDO1 LEDO2 LEDISET=20mA Duty=100% (I _{MAX} - I _{AVG}) / I _{AVG}		0.3	2	%
LEDO1, 2 max current	I _{max}	LEDO1 LEDO2	40			mA
LEDO1, 2 leak current	I _{lk}	LEDO1 LEDO2			1	μA
OVP Voltage	V _{ovp}	SW_pin over voltage threshold	36	37.5	39	V
SWOUT ON resistance	R _{on}	I _L =100mA		250		mΩ
NMOS Switch Current Limit	I _{LIM}		1	1.5		A
OSC Frequency	F _{osc}		1000	1200	1500	kHz
High level input voltage	V _{INH}	EN PWM	1.2		V _{CC}	V
Low level input voltage	V _{INL}	EN PWM	0		0.4	V
Under Voltage Lockout	V _{uvlo}	VIN falling		2.2		V
EN pin output voltage for Acknowledge	V _{ack}	R _{pullup} =15kΩ			0.4	V

Product parametric performance is indicated in the Electrical Characteristics for the listed test conditions, unless otherwise noted. Product performance may not be indicated by the Electrical Characteristics if operated under different conditions.

LV52207XA

Recommended EN PWM Timing at $T_a=25^{\circ}\text{C}$, $V_{CC}=3.6\text{V}$, unless otherwise specified

Parameter	Symbol	Conditions	Ratings			Unit
			min	typ	max	
Dimming mode selectable time	Tsel		1		2.2	ms
Delay time to start digital mode detection	Tw0		100			μs
Low time to switch to digital mode	Tw1		260			μs
EN pin low time to shutdown	Toffen		2.5			ms
PWM pin low time to shutdown	Toffpwm		20			ms
1-wire start time for digital mode programming	Tstart		2			μs
1-wire end time for digital mode programming	Tend		2		360	μs
1-wire High time of bit 0	Th0	Bit detection=0	2		180	μs
1-wire Low time of bit 0	Tl0	Bit detection=0	$T_{h0} \times 2$		360	μs
1-wire High time of bit 1	Th1	Bit detection=1	$T_{l1} \times 2$		360	μs
1-wire Low time of bit 1	Tl1	Bit detection=1	2		180	μs
DCDC startup delay	Tdel			5		ms
Delay time of Acknowledge	Tackd				2	μs
Duration of Acknowledge	Tack				512	μs

LV52207XA

Package Dimensions

unit : mm

WLCSP9, 1.31x1.31
CASE 567HX
ISSUE B

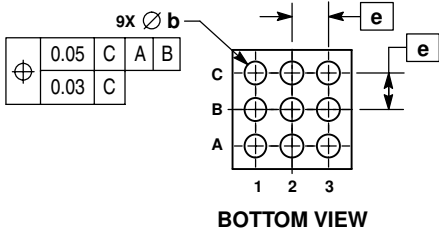
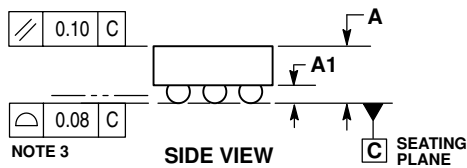
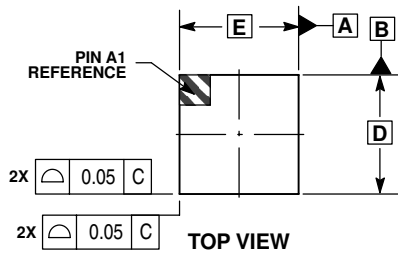

- NOTES:
1. DIMENSIONING AND TOLERANCING PER ASME Y14.5M, 1994.
 2. CONTROLLING DIMENSION: MILLIMETERS.
 3. COPLANARITY APPLIES TO THE SPHERICAL CROWNS OF THE SOLDER BALLS.

MILLIMETERS		
DIM	MIN	MAX
A	---	0.625
A1	0.16	0.26
b	0.21	0.31
D	1.31 BSC	
E	1.31 BSC	
e	0.40 BSC	

RECOMMENDED SOLDERING FOOTPRINT*

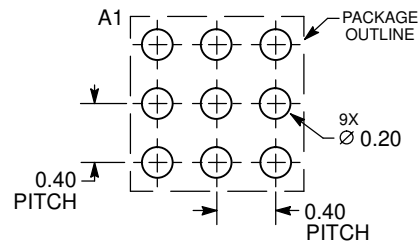

DIMENSIONS: MILLIMETERS

*For additional information on our Pb-Free strategy and soldering details, please download the ON Semiconductor Soldering and Mounting Techniques Reference Manual, SOLDERRM/D.

LV52207XA is as follows.

MARKING DIAGRAM

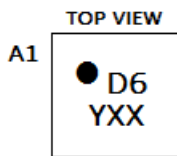

D6 = Device Code
 YXX = Assembly Lot Code

Block Diagram

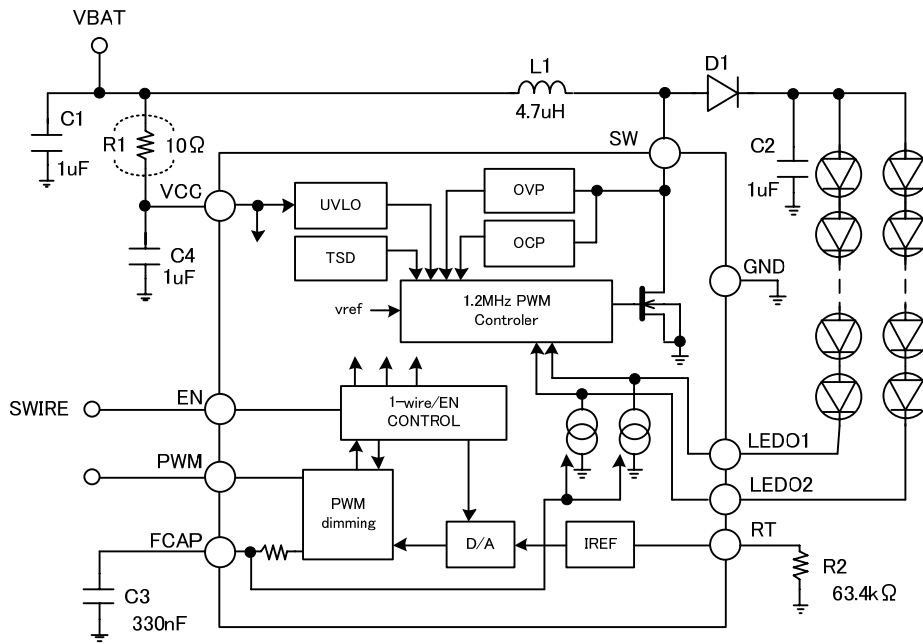

- L1 : VLS3012E-4R7M (TDK), VLF504015-4R7(TDK)
 VLS3012E-100M (TDK), VLF504015-100M(TDK)
- D1 : MBR0540T1 (ON semi), NSR05F40 (ON semi)
- C2 : GRM21BR71H105K (Murata), C1608X5R1H105K (TDK)

Fig2. Block Diagram

Pin Connection

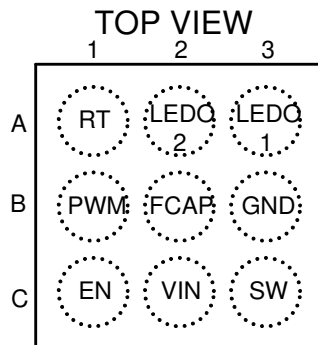

LV52207XA

Pin Function

PIN #	Pin Name	Description
A1	RT	Connecting a resistor terminal for Full scale LED current setting
A2	LEDO2	Constant Current Output_pin2
A3	LEDO1	Constant Current Output_pin1
B1	PWM	PWM dimming input (active High).
B2	FCAP	Filtering capacitor terminal for PWM mode
B3	GND	Ground
C1	EN	1-wire control and Enable control input (active High).
C2	VIN	Supply voltage.
C3	SW	Switch pin. Drain of the internal power FET.

Pd-Max

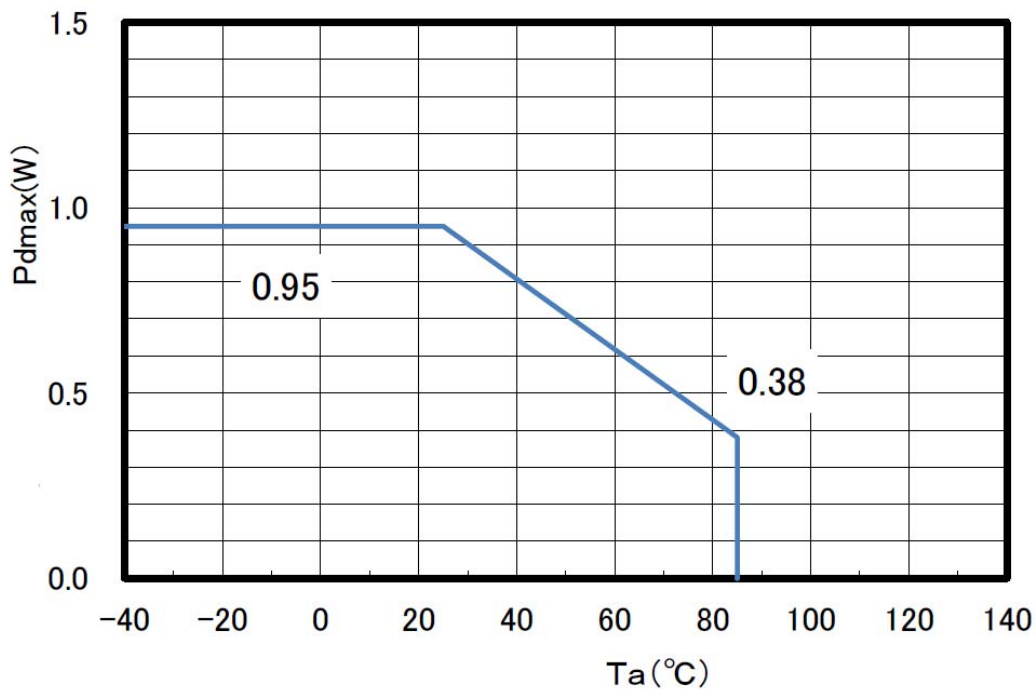

Mounted on a specified board : 70mm×70mm×1.6mm (4 layer glass epoxy)

LED Current Setting (max sink current)

LED_full current is set by an external resistor connected between the RT pin and ground.

$$I(\text{LED_full}) = 2113 \times (V(\text{RT}) / R(\text{RT_res}))$$

V(RT) : RT_pin DC Voltage typ=0.6V
 R(RT_res) : RT_pin resistor

RT_res=63.4kΩ : I(LED_full)=20mA

BRIGHTNESS CONTROL

The LV52207XA controls the DC current of the dual channels. The DC current control is normally referred to as analog dimming mode.

The LV52207XA can receive digital commands at the EN pin (1-wire digital interface) (**Digital Mode**) and the PWM signals at the PWM pin (PWM interface) (**PWM Mode**) for brightness dimming.

Dimming Mode Selection

Dimming Mode is selected by a specific pattern of the EN pin within Tsel(1ms) from the startup of the device every time.

Digital Mode

To enter Digital Mode, EN pin should be taken high for more than Tw0(100μs) from the first rising edge and keep low state for Tw1(260μs) before Tsel(1ms). When using Digital mode, the PWM pin should be kept high.

It is required sending the device address byte and the data byte to select LEDI. The bit detection is determined by the ratio of Th and Tl(See Fig5). The start condition for the bit transmission required EN pin high for at least Tstart. The end condition is required EN pin low for at least Tend. When data is not being transferred, EN pin is set in the “H” state. These registers are initialized with shutdown.

Start up and Shutdown

The device becomes enabled when EN pin is initially taken high. The dimming mode is determined within Tsel and the boost converter start up after Tdel. To place the device into shutdown mode, the SWIRE must be held low for Toff.

Digital MODE

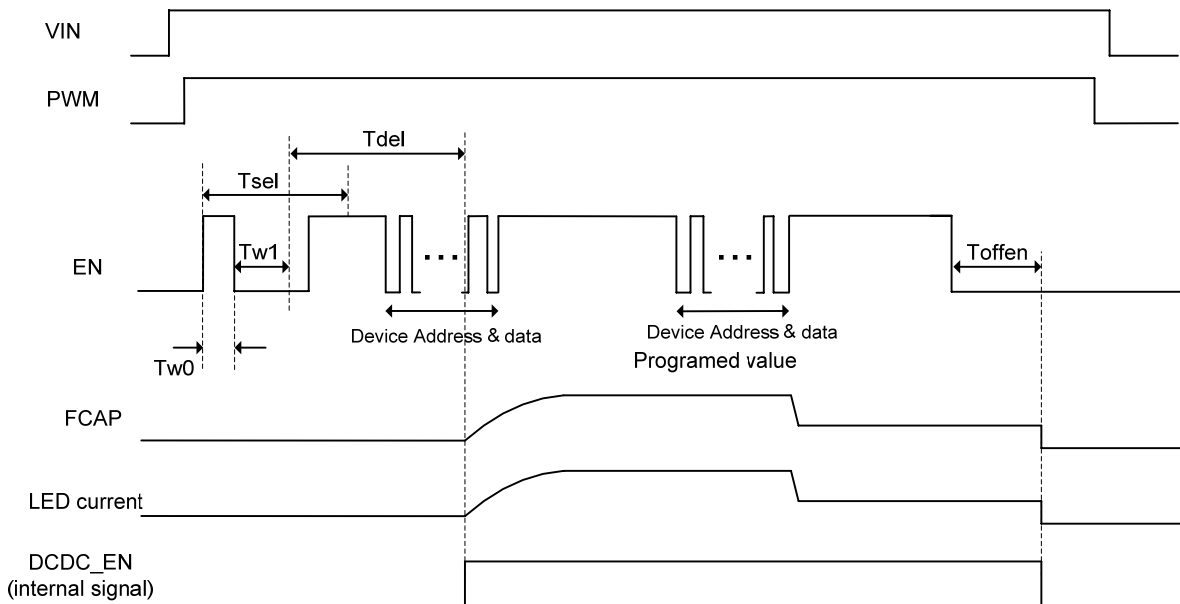

Fig3. Start up and shutdown diagram (**DIGITAL MODE**)

1-Wire Programming

Figure 15 and Table 2 give an overview of the protocol used by LV52207XA. A command consists of 24 bits, including an 8-bit device address byte and a 16-bit data byte. All of the 24 bits should be transmitted together each time, and the LSB bit should be transmitted first. In the LV52207XA, the device address (DA7(MSB)to DA0(LSB)) is specified as "10001111". AKct is setting for the acknowledge response. If the device address and the data byte are transferred on AKct=1, the ACK signal is sent from the receive side to the send side. The acknowledge signal is issued when EN pin on the send side is released and EN pin on the receive side is set to low state.

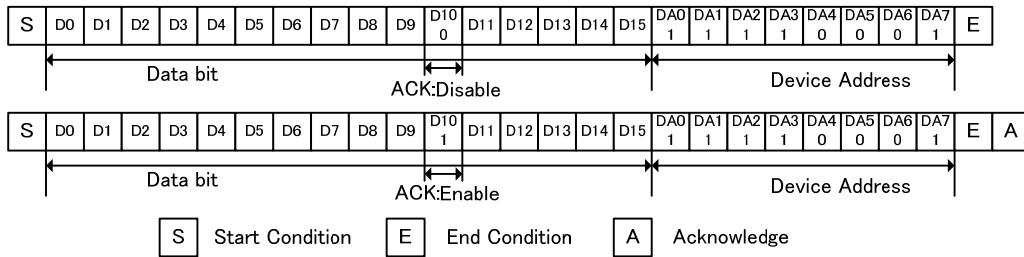

Fig4. Example of writing data

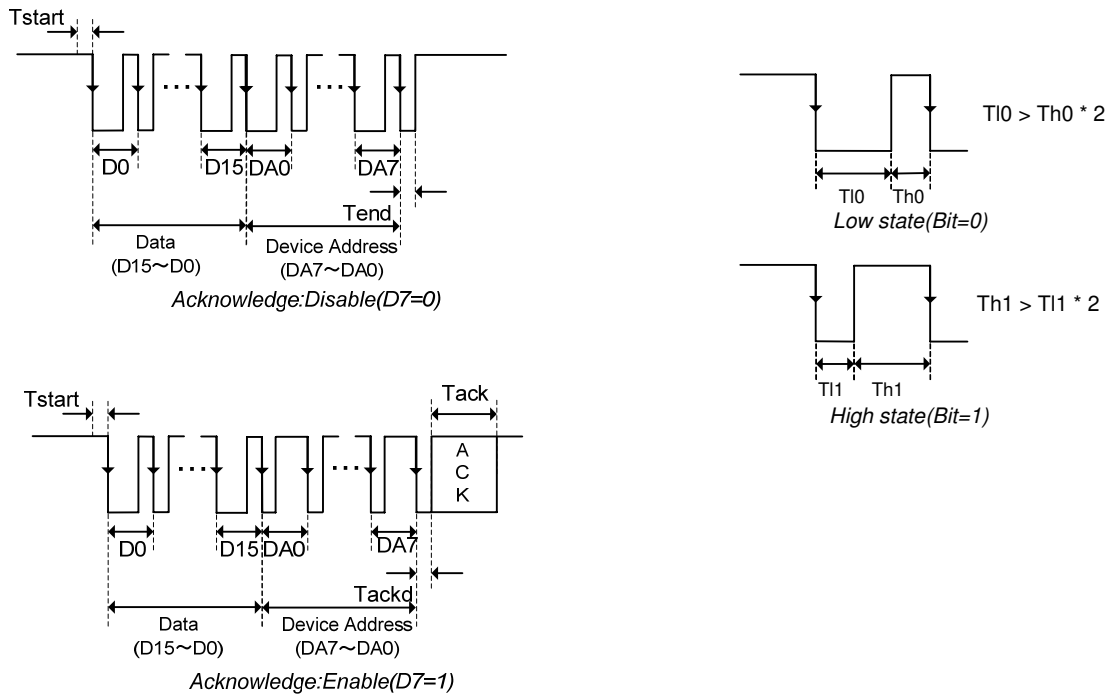

Fig5. Bit detection Diagram

LV52207XA

BITE	Register	BIT	Description
Device Address (0x8F)	DA7	23(MSB)	1
	DA6	22	0
	DA5	21	0
	DA4	20	0
	DA3	19	1
	DA2	18	1
	DA1	17	1
	DA0	16	1
Data	D15	15	Data bit 15 No information. Write 0 to this bit.
	D14	14	Data bit 14 No information. Write 0 to this bit.
	D13	13	Data bit 13 No information. Write 0 to this bit.
	D12	12	Data bit 12 No information. Write 0 to this bit.
	D11	11	Data bit 11 No information. Write 0 to this bit.
	AKct(D10)	10	0 = Acknowledge disabled 1 = Acknowledge enabled
	D9	9	Data bit 9
	D8	8	Data bit 8
	D7	7	Data bit 7
	D6	6	Data bit 6
	D5	5	Data bit 5
	D4	4	Data bit 4
	D3	3	Data bit 3
	D2	2	Data bit 2
	D1	1	Data bit 1 LSB of brightness code
D0	0(LSB)	Data bit 0 No information.	

Table1. Bit Description

LED Current setting RT resistor=63.4KΩ (20mA)

LED current = I(LED_full) x code/255= LEDO1current=LEDO2current

code	D8	D7	D6	D5	D4	D3	D2	D1	LED Current(mA)
0	0	0	0	0	0	0	0	0	0 Unavailable
1	0	0	0	0	0	0	0	1	0.22
2	0	0	0	0	0	0	1	0	0.30
3	0	0	0	0	0	0	1	1	0.38
4	0	0	0	0	0	1	0	0	0.47
5	0	0	0	0	0	1	0	1	0.55
6	0	0	0	0	0	1	1	0	0.63
7	0	0	0	0	0	1	1	1	0.70
8	0	0	0	0	1	0	0	0	0.78
9	0	0	0	0	1	0	0	1	0.86
10	0	0	0	0	1	0	1	0	0.94
.
246	1	1	1	1	0	1	1	0	19.30
247	1	1	1	1	0	1	1	1	19.38
248	1	1	1	1	1	0	0	0	19.46
249	1	1	1	1	1	0	0	1	19.54
250	1	1	1	1	1	0	1	0	19.61
251	1	1	1	1	1	0	1	1	19.69
252	1	1	1	1	1	1	0	0	19.77
253	1	1	1	1	1	1	0	1	19.84
254	1	1	1	1	1	1	1	0	19.93
255	1	1	1	1	1	1	1	1	20 *Default

Table2. Data Register vs LED current sink

PWM Mode

The dimming mode is set to PWM mode when it is not recognized as a digital mode within Tsel. The LV52207XA can receive the PWM signals at the PWM pin (PWM interface)(**PWM Mode**) for brightness dimming. When using PWM interface, the EN pin should be kept high. If EN pin is H, PWM pin alone is used to enable and disable the IC. When EN pin is H and PWM pin is H, this IC is enable. When EN pin more than 2.5ms are low or when PWM pin more than 20ms are low, the IC is disable.

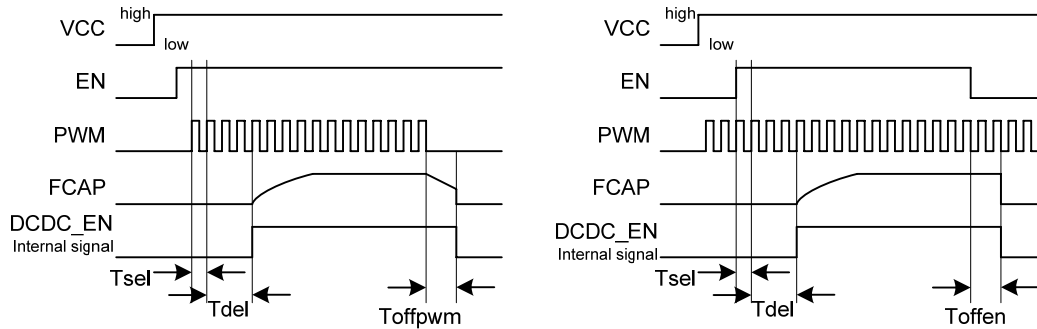

Fig6. Start up and shutdown diagram (**PWM MODE**)

LEDO1 or LEDO2 UNUSED

If only one channel is used, a user can be made to OFF by connecting to ground the unused channel. If LEDO1 pin and LEDO2 pin are connected to ground, dc/dc will not start up.

Over Voltage Protection (SW OVP)

SW pin over-voltage protection is set at 37.5V. **This IC monitors the Voltage at SW pin.** When the voltage exceed OVP threshold, the switching converter stops switching.

If SW terminal voltage exceeds a threshold V_{ovp} (37.5V typ) for 8 cycles, boost converter enters shutdown mode. In order to restart the IC, SWIRE signal is required again.

Over Voltage Protection (LEDO OVP)

LED pin over-voltage protection is set at 4.5V(rise) 3.5V(fall). **This IC monitors the Voltage at LEDO1 pin and LEDO2 pin.** When the voltage exceed LEDO OVP threshold, the switching converter stops switching. LED current sink keep.

Open LED Protection

< When one LED string becomes open.>

If one LED string is open, open channel voltage is about ground, the boost output voltage is increased and other LEDO channel voltage is increased. When SW pin voltage is reached the SW OVP threshold the LV52207XA's switching converter stops switching. When other LEDO pin voltage is reached the LEDO OVP threshold, the LV52207XA's switching converter stops switching.

< When both LED strings become open.>

If both LED strings are open, LEDO1 pin voltage and LEDO2 pin voltage is about ground, and the boost output voltage is increased

When SW pin voltage is reached the SW OVP threshold the LV52207XA's switching converter stops switching.

Over Current Protection

Current limit value for built-in power MOS is around 1.5A. The power MOS is turned off for each switching cycle when peak current through it exceeds the limit value.

Under Voltage Lock Out (UVLO)

UVLO operation works when VIN terminal voltage is below 2.2V.

Thermal Shutdown

When chip temperature is too high, boost converter is stopped.

Application Circuit Diagram

PWM dimming mode

EN pin can be used to enable or disable

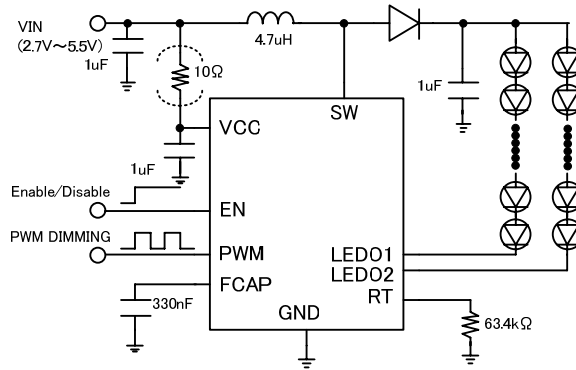

PWM dimming mode

PWM pin can be used to enable or disable

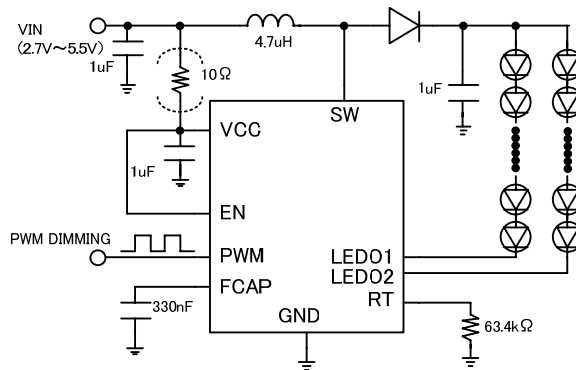

1-wire dimming mode

PWM pin can be used to enable or disable

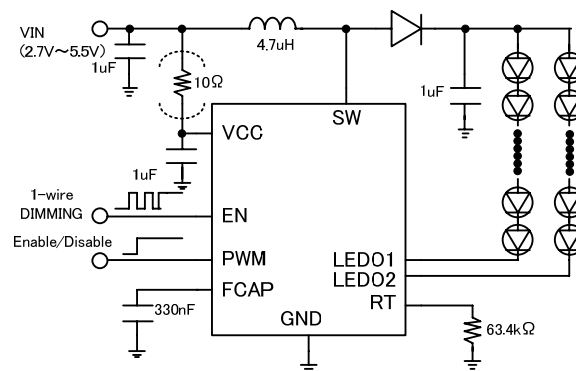

LV52207XA

1-wire dimming mode

EN pin can be used to enable or disable

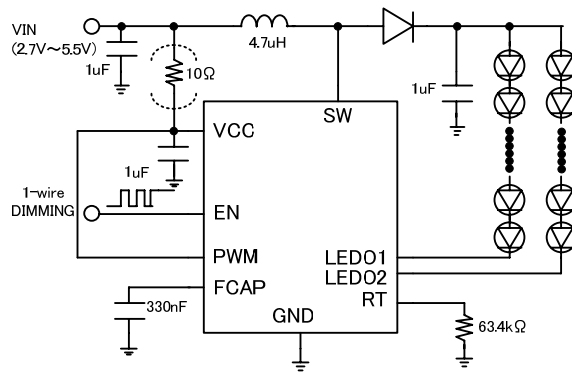

1-wire dimming mode and PWM dimming mode (CABC)

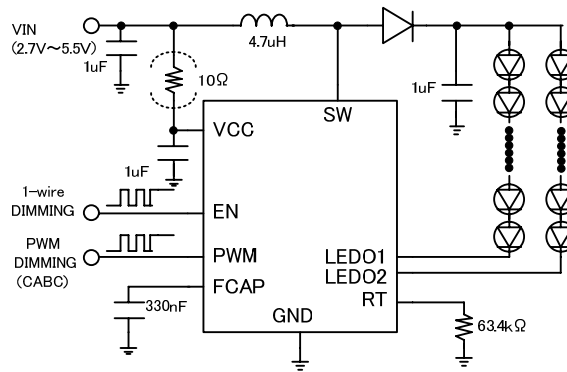

Notes start-up sequences

During Tw0 period of 1-wire, it is necessary to make PWM "High".

Fig7. Various application circuit diagram

Typical Characteristics (VIN=3.6V, L=10μH, T=25°C, unless otherwise specified)

Efficiency vs PWM DIMMING (20mA/string)

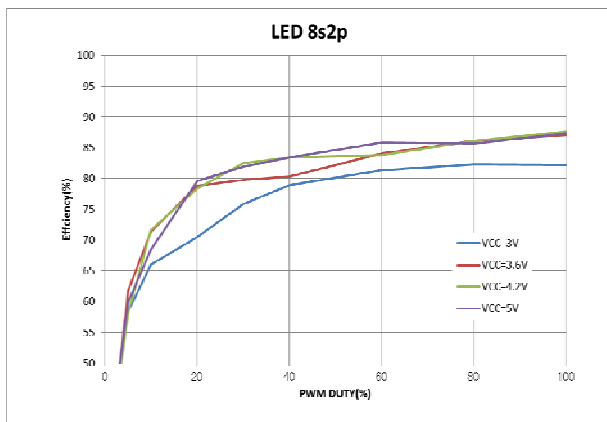
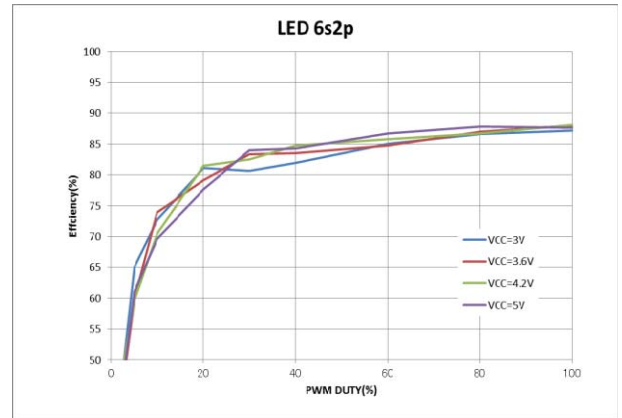
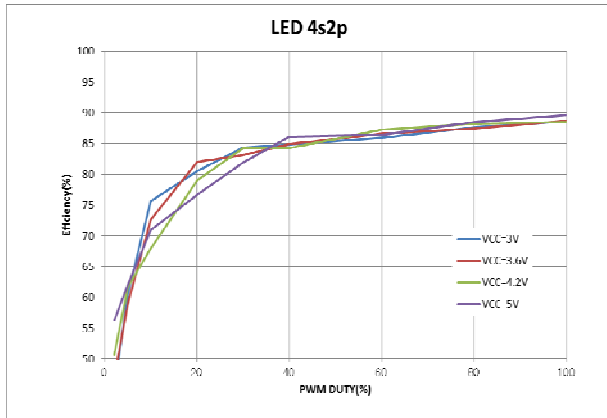

PWM DIMMING

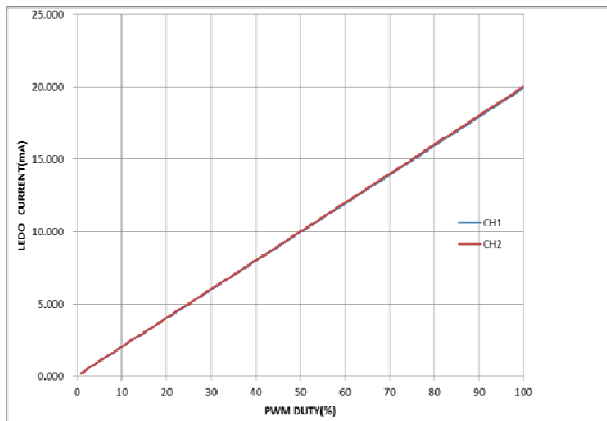

1-wire DIMMING

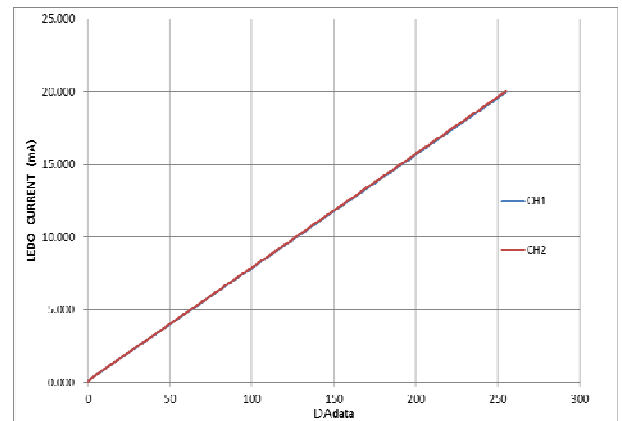

CABC DIMMING

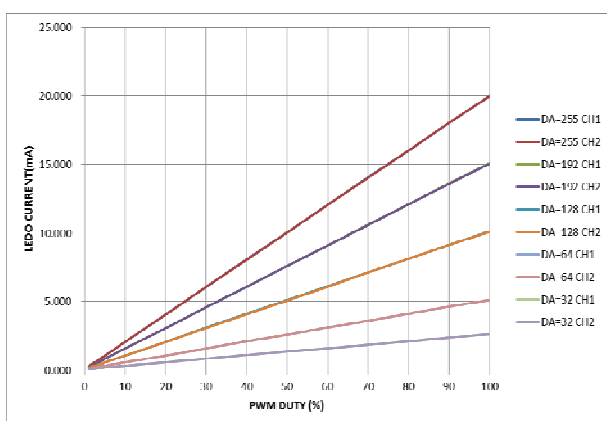

START UP WAVEFORM

PWM DUTY=100%
LED 6s2p

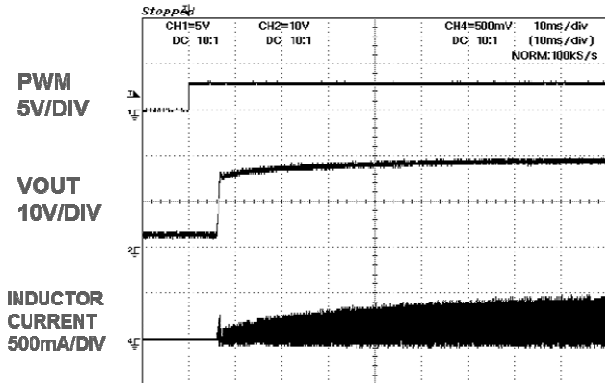

PWM DUTY=20%
LED 6s2p

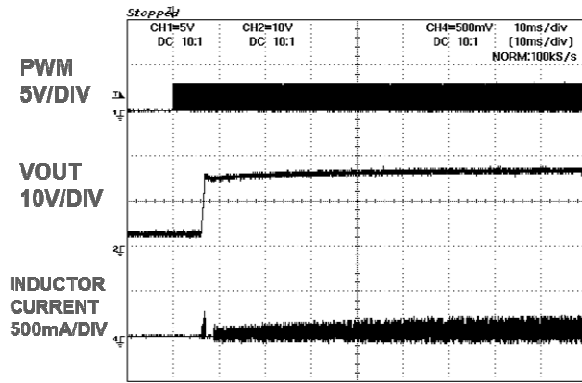

SHUTDOWN WAVEFORM

PWM DUTY=100%
LED 6s2p

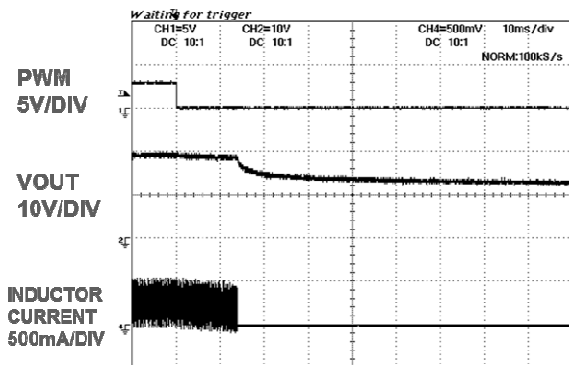

PWM DUTY=20%
LED 6s2p

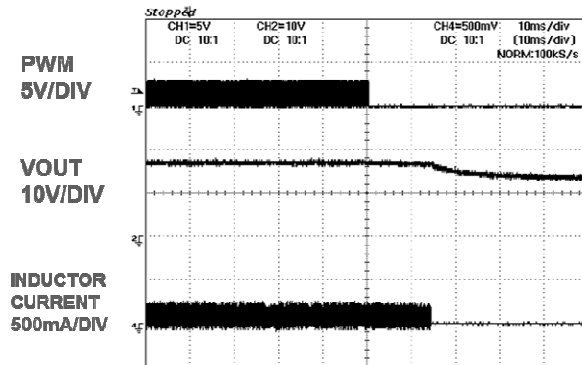

SWITCHING WAVEFORM

PWM DUTY=100%
LED 6s2p

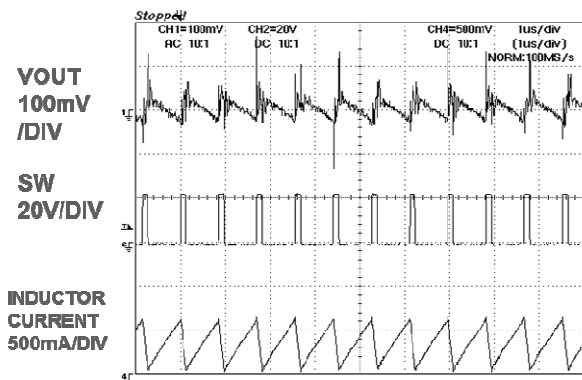

PWM DUTY=20%
LED 6s2p

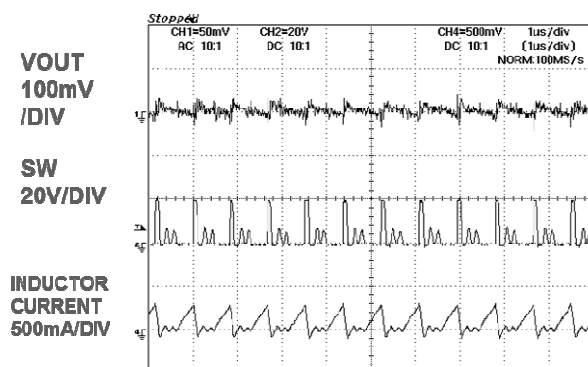

LV52207XA

Packing Specification of Embossed Carrier Taping

WLP9 (1.31X1.31)

3. PARTS No. ON BAR CODE LABEL

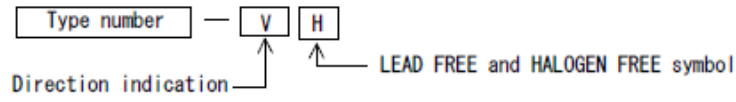

4. REEL DIMENSIONS

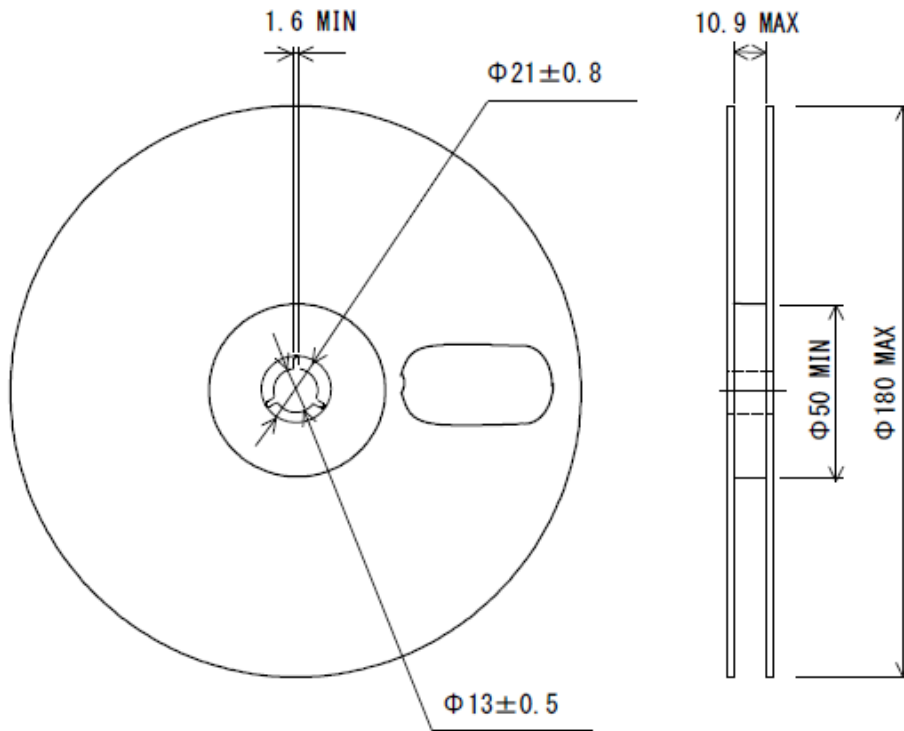

MODEL : RRM-08B

UNIT : mm

Packing Specification of Embossed Carrier Taping

WLP9 (1.31X1.31)

Carrier tape type number	Package code	Maximum number of ICs contained (pcs.)		Packing form
		Reel	Inner box	Inner box. BOX (TE-1208)
CARR (BD0145X0145)	WLP9 (1.31X1.31)	5,000	5,000	1 Reels contained Dimensions:mm 190×37×190

MPN Label

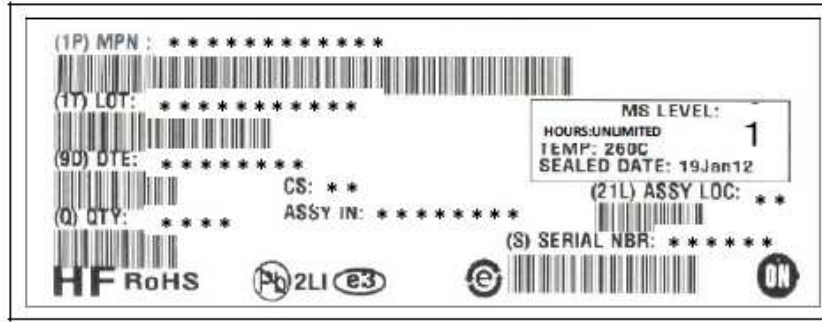

Packing Method

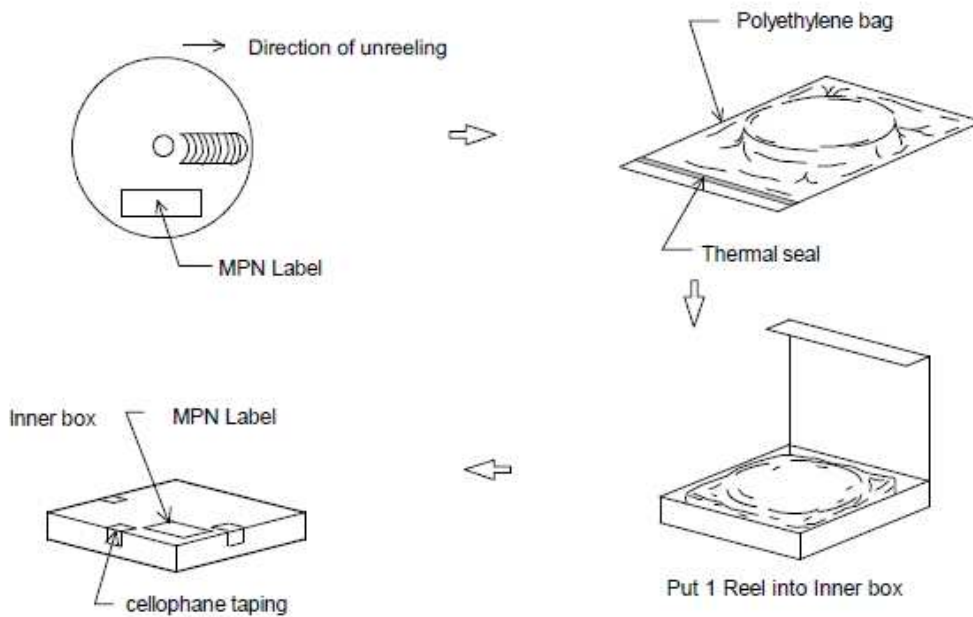

LV52207XA

ORDERING INFORMATION

Device	Package	Shipping (Qty / Packing)
LV52207XA-VH	WLP9 (1.31 x 1.31) (Pb-Free / Halogen Free)	5000 / Tape & Reel

ON Semiconductor and the ON logo are registered trademarks of Semiconductor Components Industries, LLC (SCILLC). SCILLC owns the rights to a number of patents, trademarks, copyrights, trade secrets, and other intellectual property. A listing of SCILLC's product/patent coverage may be accessed at www.onsemi.com/site/pdf/Patent-Marking.pdf. SCILLC reserves the right to make changes without further notice to any products herein. SCILLC makes no warranty, representation or guarantee regarding the suitability of its products for any particular purpose, nor does SCILLC assume any liability arising out of the application or use of any product or circuit, and specifically disclaims any and all liability, including without limitation special, consequential or incidental damages. "Typical" parameters which may be provided in SCILLC data sheets and/or specifications can and do vary in different applications and actual performance may vary over time. All operating parameters, including "Typicals" must be validated for each customer application by customer's technical experts. SCILLC does not convey any license under its patent rights nor the rights of others. SCILLC products are not designed, intended, or authorized for use as components in systems intended for surgical implant into the body, or other applications intended to support or sustain life, or for any other application in which the failure of the SCILLC product could create a situation where personal injury or death may occur. Should Buyer purchase or use SCILLC products for any such unintended or unauthorized application, Buyer shall indemnify and hold SCILLC and its officers, employees, subsidiaries, affiliates, and distributors harmless against all claims, costs, damages, and expenses, and reasonable attorney fees arising out of, directly or indirectly, any claim of personal injury or death associated with such unintended or unauthorized use, even if such claim alleges that SCILLC was negligent regarding the design or manufacture of the part. SCILLC is an Equal Opportunity/Affirmative Action Employer. This literature is subject to all applicable copyright laws and is not for resale in any manner.