



Chipsmall Limited consists of a professional team with an average of over 10 year of expertise in the distribution of electronic components. Based in Hongkong, we have already established firm and mutual-benefit business relationships with customers from,Europe,America and south Asia,supplying obsolete and hard-to-find components to meet their specific needs.

With the principle of “Quality Parts,Customers Priority,Honest Operation,and Considerate Service”,our business mainly focus on the distribution of electronic components. Line cards we deal with include Microchip,ALPS,ROHM,Xilinx,Pulse,ON,Everlight and Freescale. Main products comprise IC,Modules,Potentiometer,IC Socket,Relay,Connector.Our parts cover such applications as commercial,industrial, and automotives areas.

We are looking forward to setting up business relationship with you and hope to provide you with the best service and solution. Let us make a better world for our industry!



Contact us

Tel: +86-755-8981 8866 Fax: +86-755-8427 6832

Email & Skype: info@chipsmall.com Web: www.chipsmall.com

Address: A1208, Overseas Decoration Building, #122 Zhenhua RD., Futian, Shenzhen, China





LV8086T

Bi-CMOS LSI

Forward/Reverse Motor Driver

ON Semiconductor®

<http://onsemi.com>

Overview

LV8086T is a 2ch forward/reverse motor driver IC using D-MOS FET for output stage. As MOS circuit is used, it supports the PWM input. Its features are that the on resistance (0.75Ω typ) and current dissipation are low. It also provides protection functions such as heat protection circuit and reduced voltage detection and is optimal for the motors that need high-current.

Functions

- 2ch forward/reverse motor driver
- Low power consumption
- Built-in charge pump circuit
- Compact TSSOP24 package
- Possible to respond to 3V control voltage and 6V motor voltage device
- Low ON resistance 1.2Ω
- Built-in low voltage reset and thermal shutdown circuit
- Four mode function forward/reverse, brake, stop.

Specifications

Absolute Maximum Ratings at $T_a = 25^\circ\text{C}$, $\text{SGND} = \text{PGND} = 0\text{V}$

Parameter	Symbol	Conditions	Ratings	Unit
Supply voltage (For load)	$V_{M1,2 \text{ max}}$		-0.5 to 7.5	V
Supply voltage (For control)	$V_{CC \text{ max}}$		-0.5 to 6.0	V
Output current	$I_O \text{ max1}$	$t \leq 100\text{ms}$	1.4	A
Output peak current	$I_O \text{ max2}$	$t \leq 10\text{ms}$	2.5	A
Input voltage	$V_{IN \text{ max}}$		-0.5 to $V_{CC}+0.5$	V
Allowable power dissipation	P_d	* Mounted on a board	800	mW
Operating temperature	T_{opr}		-20 to +75	$^\circ\text{C}$
Storage temperature	T_{stg}		-55 to +150	$^\circ\text{C}$

* : Mounted on a specified board : $30 \times 50 \times 1.6\text{mm}$, glass epoxy board.

Caution 1) Absolute maximum ratings represent the value which cannot be exceeded for any length of time.

Caution 2) Even when the device is used within the range of absolute maximum ratings, as a result of continuous usage under high temperature, high current, high voltage, or drastic temperature change, the reliability of the IC may be degraded. Please contact us for the further details.

Stresses exceeding Maximum Ratings may damage the device. Maximum Ratings are stress ratings only. Functional operation above the Recommended Operating Conditions is not implied. Extended exposure to stresses above the Recommended Operating Conditions may affect device reliability.

LV8086T

Allowable Operating Ratings at $T_a = 25^\circ\text{C}$, $\text{SGND} = \text{PGND} = 0\text{V}$

Parameter	Symbol	Conditions	Ratings	Unit
Supply voltage (VM Pin)	VM		2.0 to 7.0	V
Supply voltage (V_{CC} Pin)	V_{CC}		2.7 to 5.5	V
Input signal voltage	V_{IN}		0 to V_{CC}	V
Input signal frequenc	f max		100	kHz
Capacitor for charge pump	C1, C2, C3		0.001 to 0.1	μF

Electrical Characteristics at $T_a = 25^\circ\text{C}$, $V_{CC} = \text{VM1} = \text{VM2} = 5.0\text{V}$, $\text{SGND} = \text{PGND} = 0\text{V}$, unless especially specified.

Parameter	Symbol	Conditions	Ratings			Unit
			min	typ	max	
Supply current for load at standby	IMO	EN = 0V			1.0	μA
Supply current for control at standby	ICO	EN = 0V, IN1 = IN2 = IN3 = IN4 = 0V			1.0	μA
Current drain during operation	IC1	EN = 5V, VG at no load		0.7	1.2	mA
H-level input voltage	V_{IH}	$2.7\text{V} \leq V_{CC} \leq 5.5\text{V}$	$0.6V_{CC}$		V_{CC}	V
L-level input voltage	V_{IL}	$2.7\text{V} \leq V_{CC} \leq 5.5\text{V}$	0		$0.2V_{CC}$	V
H-level input current (IN1, IN2, IN3, IN4)	I_{IH}				1.0	μA
L-level input current (IN1, IN2, IN3, IN4)	I_{IL}		-1.0			μA
Pull-down resistance (EN1, 2)	RUP		100	200	400	$\text{k}\Omega$

$T_a = 25^\circ\text{C}$, $V_{CC} = \text{VM} = 5.0\text{V}$, $\text{SGND} = \text{PGND} = 0\text{V}$

Parameter	Symbol	Conditions	Ratings			Unit
			min	typ	max	
Output ON resistance	RON	Sum of ON resistances at top and bottom		0.75	1.2	Ω
Charge pump voltage	VG		8.5		10.5	V
Low-voltage detection operation voltage	VCS		2.15	2.30	2.45	V
Thermal shutdown operation temperature	Tth			180		$^\circ\text{C}$
Charge pump capacity (IG = $500\mu\text{A}$)	VGLOAD		8	9		V
IG current dissipation (Fin = 20kHz)	IG				350	μA
Charge pump start time	TVG	CVG = $0.1\mu\text{F}$			1.0	ms
Output block	Turn on time	TPLH		0.2	0.4	μs
	Turn off time	TPHL		0.2	0.4	μs

Remarks

1. It shows current dissipation of VM1,2 pin in output OFF state.
2. It shows current dissipation of V_{CC} pin in stand-by state.
(The standard current depends on EN pin pull-down resistance.)
3. It shows current dissipation of V_{CC} pin in state of EN = 5V (stand-by), including current dissipation of VG pin.
4. For IN1, IN2, IN3 and IN4 pins, no pull-down and pull-up resistance is needed. (High impedance pin)
5. It shows sum of upper and lower saturation voltages of OUT pin.
6. It controls charge-pump oscillation and makes specified voltage.
7. When low voltage is detected, the lower output is turned OFF.
8. When thermal protection circuit is activated, the lower output is turned OFF.
When the heat temperature is fallen, it is turned ON again.
9. IG (VG pin load current) = $500\mu\text{A}$
10. It shows VG pin current dissipation in state of PWM input for IN pin.
11. It specifies start-up time from 10% to 90% when VG is in non-load state
(when setting the capacitor between VG and GND to $0.1\mu\text{F}$ and V_{CC} is 5V).
12. It specifies 10% to 90% for start-up and 90% to 10% for shut-down.

LV8086T

Package Dimensions

unit : mm (typ)
3260A

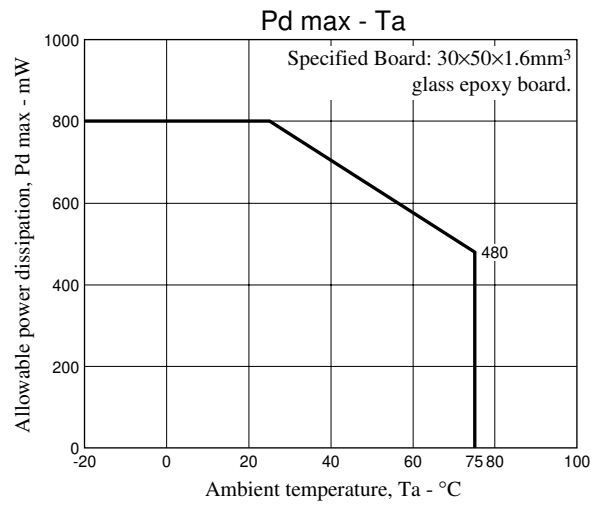
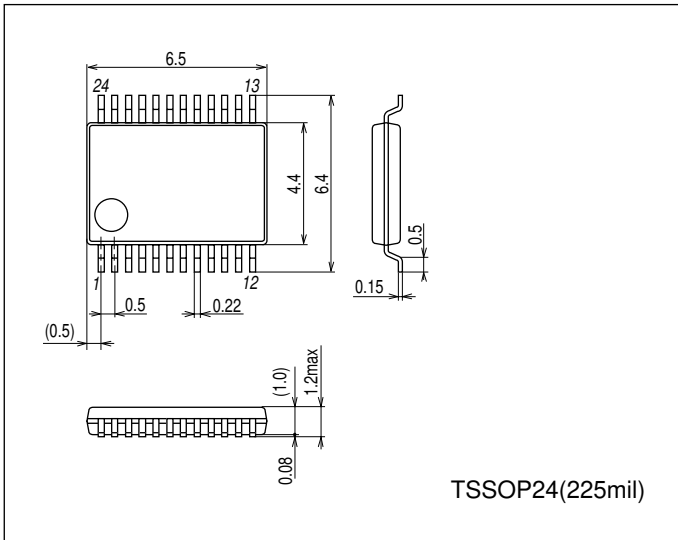

Pin Assignment

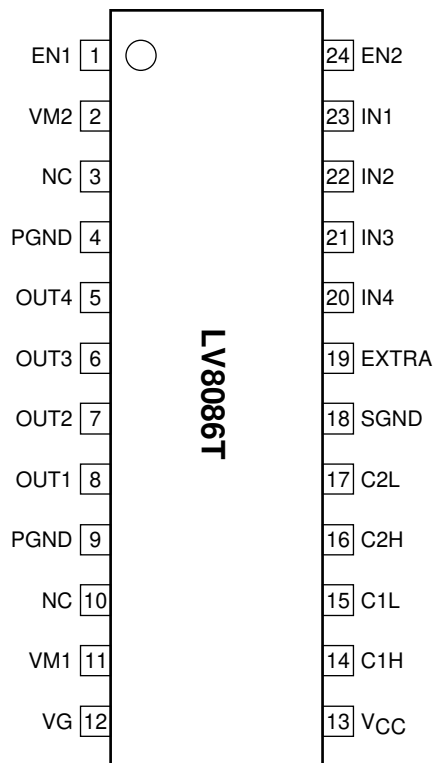

LV8086T

Block Diagram

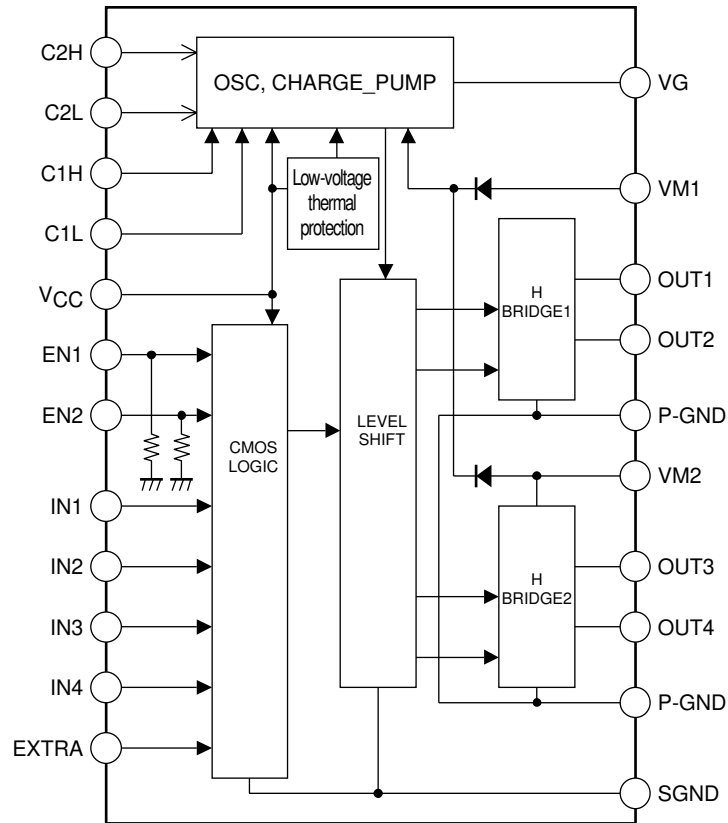

Truth table

EXTRA	EN1 (EN2)	IN1 (IN3)	IN2 (IN4)	OUT1 (OUT3)	OUT2 (OUT4)	Circuit of Charge Pump	Mode
L	H	H	H	L	L	ON	Brake
		H	L	H	L		Forward
		L	H	L	H		Reverse
		L	L	Z	Z		Standby
	L	-	-	L	L	OFF	Standby
H	H	H	-	H	L	ON	Forward
		L	-	L	H		Reverse
	L	-	-	L	L		Brake

- : Don't care Z : High-Impedance

* Current drain becomes zero in the standby mode.

* The output side becomes OFF, with motor drive stopped, during voltage reduction and thermal protection.

LV8086T

Pin Functions

Pin No.	Pin name	Function	Equivalent Circuit
15 17	C1L C2L	Voltage raising capacitor connection pin	
14 16	C1H C2H	Voltage raising capacitor connection pin	
23 22 21 20 19	IN1 IN2 IN3 IN4 EXTRA	Driver output changeover	
1 24	EN1 EN2	Logic enable pin TOUT output control pin (Pull-down resistor incorporated)	
8 7 6 5	OUT1 OUT2 OUT3 OUT4 PGND	Driver output pin	
2 11	VM2 VM1	Motor power supply	
13	V _{CC}	Logic power supply	
12	VG	Driver drive circuit power supply	
18	SGND	Logic GND	
9 4	PGND PGND	Driver GND (both terminals to be connected)	

Sample Application Circuit

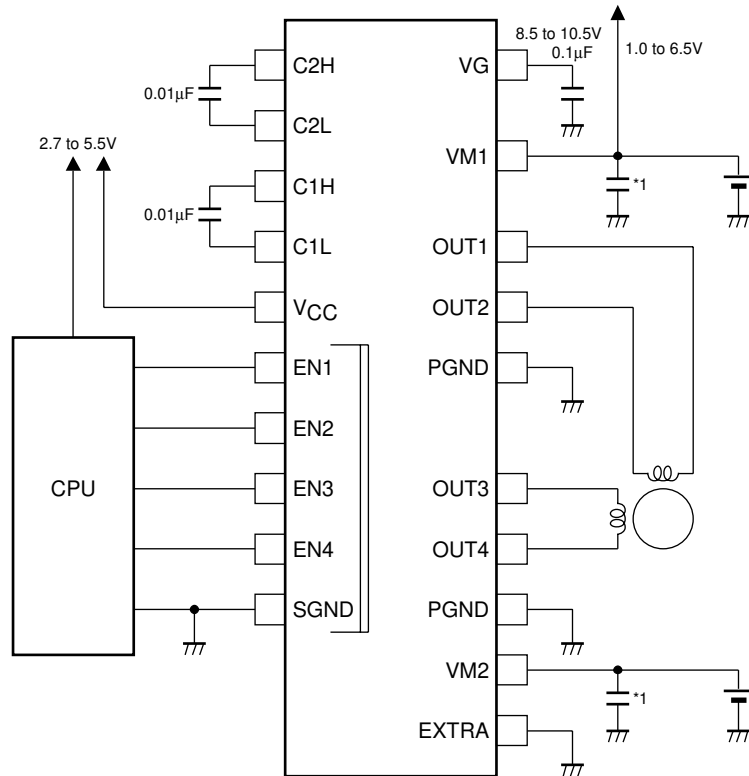

*1: Connect a kickback absorption capacitor directly near IC. Coil kickback may cause rise of the voltage of VM line, and the voltage exceeding the maximum rating may be applied momentarily, resulting in deterioration or damage of IC.

ON Semiconductor and the ON logo are registered trademarks of Semiconductor Components Industries, LLC (SCILLC). SCILLC owns the rights to a number of patents, trademarks, copyrights, trade secrets, and other intellectual property. A listing of SCILLC's product/patent coverage may be accessed at www.onsemi.com/site/pdf/Patent-Marking.pdf. SCILLC reserves the right to make changes without further notice to any products herein. SCILLC makes no warranty, representation or guarantee regarding the suitability of its products for any particular purpose, nor does SCILLC assume any liability arising out of the application or use of any product or circuit, and specifically disclaims any and all liability, including without limitation special, consequential or incidental damages. "Typical" parameters which may be provided in SCILLC data sheets and/or specifications can and do vary in different applications and actual performance may vary over time. All operating parameters, including "Typicals" must be validated for each customer application by customer's technical experts. SCILLC does not convey any license under its patent rights nor the rights of others. SCILLC products are not designed, intended, or authorized for use as components in systems intended for surgical implant into the body, or other applications intended to support or sustain life, or for any other application in which the failure of the SCILLC product could create a situation where personal injury or death may occur. Should Buyer purchase or use SCILLC products for any such unintended or unauthorized application, Buyer shall indemnify and hold SCILLC and its officers, employees, subsidiaries, affiliates, and distributors harmless against all claims, costs, damages, and expenses, and reasonable attorney fees arising out of, directly or indirectly, any claim of personal injury or death associated with such unintended or unauthorized use, even if such claim alleges that SCILLC was negligent regarding the design or manufacture of the part. SCILLC is an Equal Opportunity/Affirmative Action Employer. This literature is subject to all applicable copyright laws and is not for resale in any manner.