



Chipsmall Limited consists of a professional team with an average of over 10 year of expertise in the distribution of electronic components. Based in Hongkong, we have already established firm and mutual-benefit business relationships with customers from,Europe,America and south Asia,supplying obsolete and hard-to-find components to meet their specific needs.

With the principle of “Quality Parts,Customers Priority,Honest Operation,and Considerate Service”,our business mainly focus on the distribution of electronic components. Line cards we deal with include Microchip,ALPS,ROHM,Xilinx,Pulse,ON,Everlight and Freescale. Main products comprise IC,Modules,Potentiometer,IC Socket,Relay,Connector.Our parts cover such applications as commercial,industrial, and automotives areas.

We are looking forward to setting up business relationship with you and hope to provide you with the best service and solution. Let us make a better world for our industry!



Contact us

Tel: +86-755-8981 8866 Fax: +86-755-8427 6832

Email & Skype: info@chipsmall.com Web: www.chipsmall.com

Address: A1208, Overseas Decoration Building, #122 Zhenhua RD., Futian, Shenzhen, China





SANYO Semiconductors

DATA SHEET

An ON Semiconductor Company

LV8549M

Bi-CMOS integrated circuit 12V Low Saturation Voltage Drive Stepping Motor Driver

Overview

The LV8549M is a stepping motor driver IC of low saturation voltage. It is optimal for motor drive in 12V system product a 2-phase bipolar stepping motor.

Functions

- DMOS output transistor adoption (Upper and lower total $R_{ON}=1\Omega$ typ)
- The compact package (MFP-10S) is adopted. • $V_{CC\ max}=20v$, $I_O\ max=1A$
- For one power supply (The control system power supply is unnecessary.)
- Current consumption 0 when standing by

Specifications

Absolute Maximum Ratings at $T_a = 25^\circ C$

Parameter	Symbol	Conditions	Ratings	Unit
Maximum power supply voltage	$V_{CC\ max}$		-0.3 to +20	V
Output impression voltage	V_{OUT}		-0.3 to +20	V
Input impression voltage	V_{IN}		-0.3 to +6	V
GND pin outflow current	I_{GND}	For ch	1.0	A
Allowable Power dissipation	$P_d\ max$	*	1.05	W
Operating temperature	T_{opr}		-30 to +85	$^\circ C$
Storage temperature	T_{stg}		-40 to +150	$^\circ C$

*: When mounted on the specified printed circuit board (57.0mm × 57.0mm × 1.6mm), glass epoxy, both sides

Caution 1) Absolute maximum ratings represent the value which cannot be exceeded for any length of time.

Caution 2) Even when the device is used within the range of absolute maximum ratings, as a result of continuous usage under high temperature, high current, high voltage, or drastic temperature change, the reliability of the IC may be degraded. Please contact us for the further details.

Recommended Operating Range at $T_a = 25^\circ C$

Parameter	Symbol	Conditions	Ratings	Unit
Power supply voltage	V_{CC}		4.0 to 16	V
Input "H" level voltage	V_{INH}		+1.8 to +5.5	V
Input "L" level voltage	V_{INL}		-0.3 to +0.7	V

■ Any and all SANYO Semiconductor Co.,Ltd. products described or contained herein are, with regard to "standard application", intended for the use as general electronics equipment. The products mentioned herein shall not be intended for use for any "special application" (medical equipment whose purpose is to sustain life, aerospace instrument, nuclear control device, burning appliances, transportation machine, traffic signal system, safety equipment etc.) that shall require extremely high level of reliability and can directly threaten human lives in case of failure or malfunction of the product or may cause harm to human bodies, nor shall they grant any guarantee thereof. If you should intend to use our products for new introduction or other application different from current conditions on the usage of automotive device, communication device, office equipment, industrial equipment etc. , please consult with us about usage condition (temperature, operation time etc.) prior to the intended use. If there is no consultation or inquiry before the intended use, our customer shall be solely responsible for the use.

■ Specifications of any and all SANYO Semiconductor Co.,Ltd. products described or contained herein stipulate the performance, characteristics, and functions of the described products in the independent state, and are not guarantees of the performance, characteristics, and functions of the described products as mounted in the customer's products or equipment. To verify symptoms and states that cannot be evaluated in an independent device, the customer should always evaluate and test devices mounted in the customer's products or equipment.

SANYO Semiconductor Co., Ltd.

<http://semicon.sanyo.com/en/network>

LV8549M

Electrical Characteristics at $T_a = 25^\circ\text{C}$, $V_{CC} = 12\text{V}$

Parameter	Symbol	Conditions	Ratings			Unit
			min	typ	max	
Power supply voltage	I_{CC0}	Standby mode ENA=L			1	μA
	I_{CC1}	ENA=H		1.7	2.3	mA
Input current	I_{IN}	$V_{IN}=5\text{V}$	30	50	65	μA
Thermal shutdown operating temperature	T_{tsd}	Design certification	150	180	210	$^\circ\text{C}$
Width of temperature hysteresis	ΔT_{tsd}	Design certification		40		$^\circ\text{C}$
Low voltage protection function operation voltage	$V_{th}V_{CC}$		3.3	3.5	3.65	V
Release voltage	V_{thret}		3.55	3.8	3.95	V
Output ON resistance (Upper and lower total)	R_{ON}	$I_{OUT}=1.0\text{A}$	0.7	1	1.25	Ω
Output leak current	I_{Oleak}	$V_O=16\text{V}$			10	μA
Diode forward voltage	V_D	$I_D=1.0\text{A}$		1.0	1.2	V

Package Dimensions

unit : mm (typ)

3086B

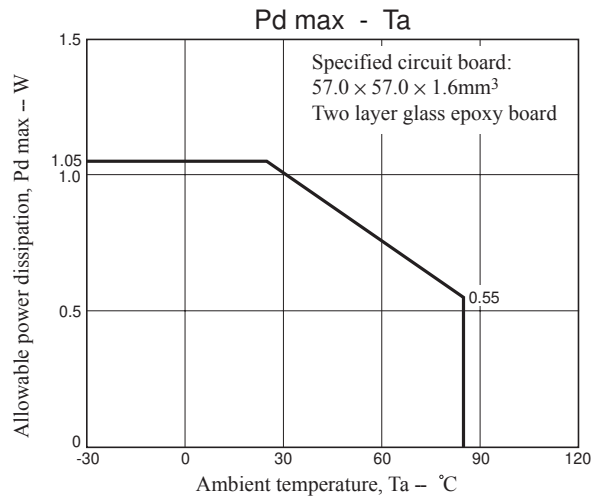
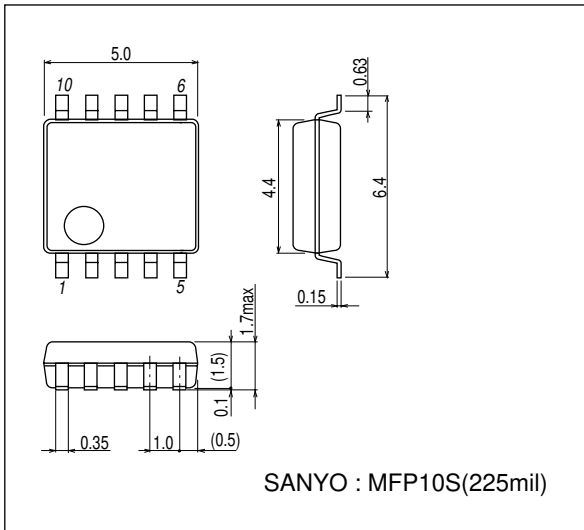

Pin Assignment

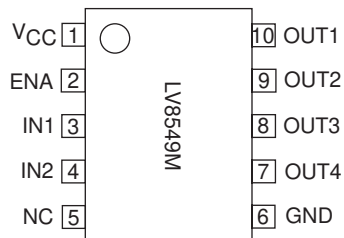

LV8549M

Block Diagram

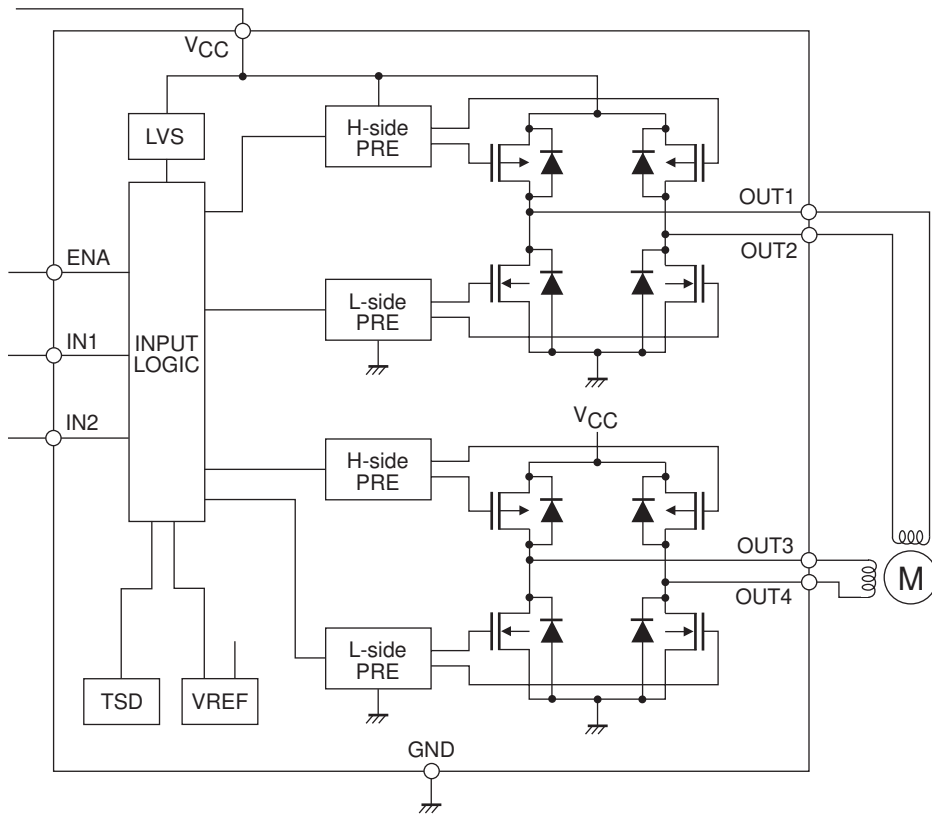

Pin function

Pin No.	Pin name	Pin function	Equivalent Circuit
1	VCC	Power-supply voltage pin. V _{CC} voltage is impressed. The permissible operation voltage is from 4.0 to 16.0(V). The capacitor is connected for stabilization for GND pin (6pin).	
2	ENA	Motor drive control input pin. It shifts from the stand-by state to a prescribed output operation corresponding to the state of the input when the ENA pin becomes a standby mode by L, the circuit current can be adjusted to 0, and it makes it to H. It is a digital input, and the range of L level input is 0 to 0.7(V) and the range of H level input are 1.8 to 5.5(V). PWM can be input. Pull-down resistance 100(kΩ) is built into in the terminal.	
3	IN1	Motor drive control input pin. Driving control input pin of OUT1 (10pin) and OUT2 (9pin). PWM can be input. With built-in pull-down resistance.	
4	IN2	Motor drive control input pin. Driving control input pin of OUT3 (8pin) and OUT4 (7pin). PWM can be input. With built-in pull-down resistance.	
5	NC		
6	GND	Ground pin.	
7	OUT4	Driving output pin. The motor coil is connected between terminal OUT3 (8pin).	
8	OUT3	Driving output pin. The motor coil is connected between terminal OUT4 (7pin).	
9	OUT2	Driving output pin. The motor coil is connected between terminal OUT1 (10pin).	
10	OUT1	Driving output pin. The motor coil is connected between terminal OUT2 (9pin).	

Operation explanation

1. STM output control logic

Input			Output				State
ENA	IN1	IN2	OUT1	OUT2	OUT3	OUT4	
L	-	-	OFF	OFF	OFF	OFF	Stand-by
H	L	L	H	L	H	L	Step 1
	H	L	L	H	H	L	Step2
	H	H	L	H	L	H	Step3
	L	H	H	L	L	H	Step4

2. About the switch time from the stand-by state to the state of operation

When ENA pin are "L", this IC has completely stopped operating. After the time of reset (about 7μs of an internal setting) it shifts to a prescribed output status corresponding to the state of the input when the signal enters the ENA pin.

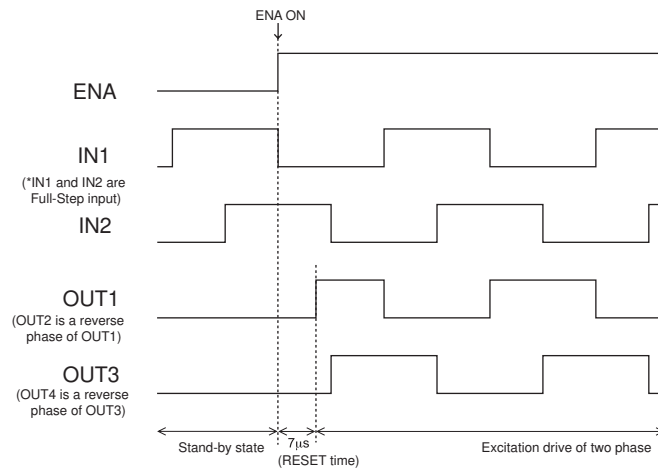

3. Example of current wave type in each excitation mode when stepping motor parallel input is controlled.

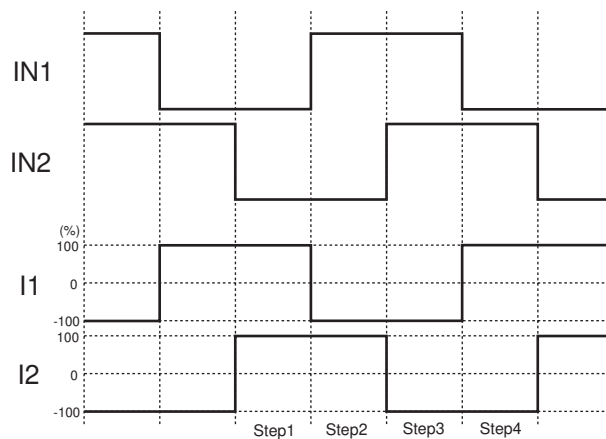

Application Circuit Example

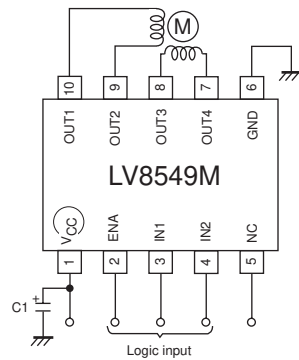

* Bypass capacitor (C1) connected between V_{CC} -GND of all examples of applied circuit recommends the electric field capacitor of $0.1\mu\text{A}$ to $10\mu\text{A}$.

Confirm there is no problem in operation in the state of the motor load including the temperature property about the value of the capacitor.

Mount the position where the capacitor is mounted on nearest IC.

- SANYO Semiconductor Co.,Ltd. assumes no responsibility for equipment failures that result from using products at values that exceed, even momentarily, rated values (such as maximum ratings, operating condition ranges, or other parameters) listed in products specifications of any and all SANYO Semiconductor Co.,Ltd. products described or contained herein.
- SANYO Semiconductor Co.,Ltd. strives to supply high-quality high-reliability products, however, any and all semiconductor products fail or malfunction with some probability. It is possible that these probabilistic failures or malfunction could give rise to accidents or events that could endanger human lives, trouble that could give rise to smoke or fire, or accidents that could cause damage to other property. When designing equipment, adopt safety measures so that these kinds of accidents or events cannot occur. Such measures include but are not limited to protective circuits and error prevention circuits for safe design, redundant design, and structural design.
- In the event that any or all SANYO Semiconductor Co.,Ltd. products described or contained herein are controlled under any of applicable local export control laws and regulations, such products may require the export license from the authorities concerned in accordance with the above law.
- No part of this publication may be reproduced or transmitted in any form or by any means, electronic or mechanical, including photocopying and recording, or any information storage or retrieval system, or otherwise, without the prior written consent of SANYO Semiconductor Co.,Ltd.
- Any and all information described or contained herein are subject to change without notice due to product/technology improvement, etc. When designing equipment, refer to the "Delivery Specification" for the SANYO Semiconductor Co.,Ltd. product that you intend to use.
- Upon using the technical information or products described herein, neither warranty nor license shall be granted with regard to intellectual property rights or any other rights of SANYO Semiconductor Co.,Ltd. or any third party. SANYO Semiconductor Co.,Ltd. shall not be liable for any claim or suits with regard to a third party's intellectual property rights which has resulted from the use of the technical information and products mentioned above.

This catalog provides information as of September, 2011. Specifications and information herein are subject to change without notice.