



Chipsmall Limited consists of a professional team with an average of over 10 year of expertise in the distribution of electronic components. Based in Hongkong, we have already established firm and mutual-benefit business relationships with customers from,Europe,America and south Asia,supplying obsolete and hard-to-find components to meet their specific needs.

With the principle of “Quality Parts,Customers Priority,Honest Operation,and Considerate Service”,our business mainly focus on the distribution of electronic components. Line cards we deal with include Microchip,ALPS,ROHM,Xilinx,Pulse,ON,Everlight and Freescale. Main products comprise IC,Modules,Potentiometer,IC Socket,Relay,Connector.Our parts cover such applications as commercial,industrial, and automotives areas.

We are looking forward to setting up business relationship with you and hope to provide you with the best service and solution. Let us make a better world for our industry!



## Contact us

Tel: +86-755-8981 8866 Fax: +86-755-8427 6832

Email & Skype: info@chipsmall.com Web: www.chipsmall.com

Address: A1208, Overseas Decoration Building, #122 Zhenhua RD., Futian, Shenzhen, China



# LV8714TA

## Dual Stepper Motor Driver with Ultra-small Micro Steps

The LV8714 is a fully integrated dual bipolar/unipolar stepper motor driver with ultra-small micro step drive capability. Alternatively, it can be used to drive four DC motors independently. The device includes low  $R_{DS(ON)}$  (upper + lower =  $0.9\Omega$ ) type MOSFETs based quad H-bridges with gate drivers and can drive up to 1.5A per H-bridge. Synchronous rectification control is implemented for all H-bridges to lower power dissipation during a MOSFET switching. The device implements constant-current control using PWM at 125 kHz (typ.) switching frequency that enables the least noise motor drive solution. A built-in linear regulator powers internal logic circuit directly from the motor supply voltage,  $V_M$ , thus eliminating need for any external regulator.

A proprietary internal current sensing mechanism is implemented that eliminates up to four external current sense power resistors and improves the system energy efficiency significantly. External  $V_{REF}$  input signal for each H-bridge controls the drive step size and can achieve over 256 micro step resolution. Individual controls signals (ENAx and INx) are provided for controlling each H-bridge channel independently with forward and reverse direction control. To enhance energy efficiency further, the device can be put into a power saving standby mode, when idle.

### Features

- Integrated quad H-bridges with independent controls
  - Dual bipolar/unipolar stepper motor or quad DC motor drive
  - Forward and reverse direction control
- Low  $R_{DS(ON)}$  (upper + lower =  $0.9\Omega$ ) type MOSFETs
- Proprietary internal current sensing
  - Eliminates up to four external current sense power resistors
- Over 256 micro step resolution with external  $V_{REF}$  inputs
- Single supply operation with a built-in internal regulator
- No external component for driving internal MOSFETs
- Constant-current control with 125 kHz (typ.) PWM switching frequency
- Low power standby mode when idle
- Synchronous rectification to reduce power dissipation
- In-built system protection features such as:
  - Under-voltage
  - Over-current
  - Over-temperature

### Typical Applications

- Surveillance Camera
- Stage light
- Scanner
- Printer



**ON Semiconductor**<sup>®</sup>

[www.onsemi.com](http://www.onsemi.com)

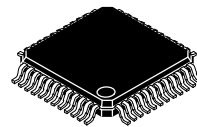

48-pin TQFP with exposed pad  
7 mm x 7 mm

### MARKING DIAGRAM

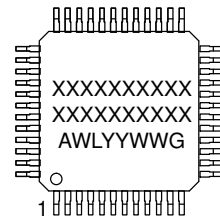

XXXXX = Specific Device Code  
A = Assembly Location  
WL = Wafer Lot  
YY = Year  
WW = Work Week  
G = Pb-Free Package

### ORDERING INFORMATION

Ordering Code:  
LV8714TA-NH

Package  
TQFP48 EP  
(Pb-Free / Halogen Free)

Shipping (Qty / packing)  
1000 / Tape & Reel

# LV8714TA

## BLOCK DIAGRAM

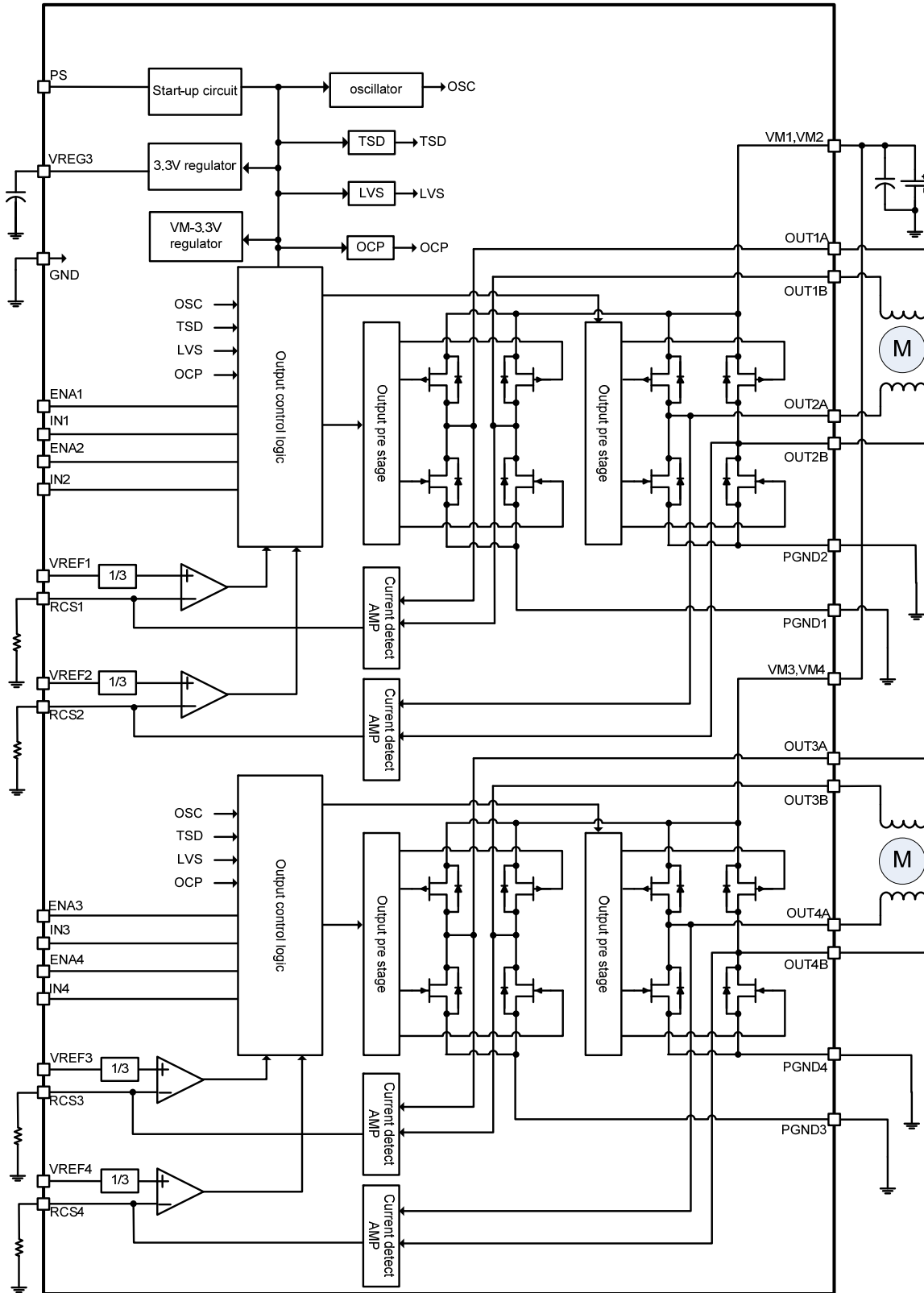

Figure 1. LV8714TA Block Diagram

# LV8714TA

## APPLICATION CIRCUIT EXAMPLES

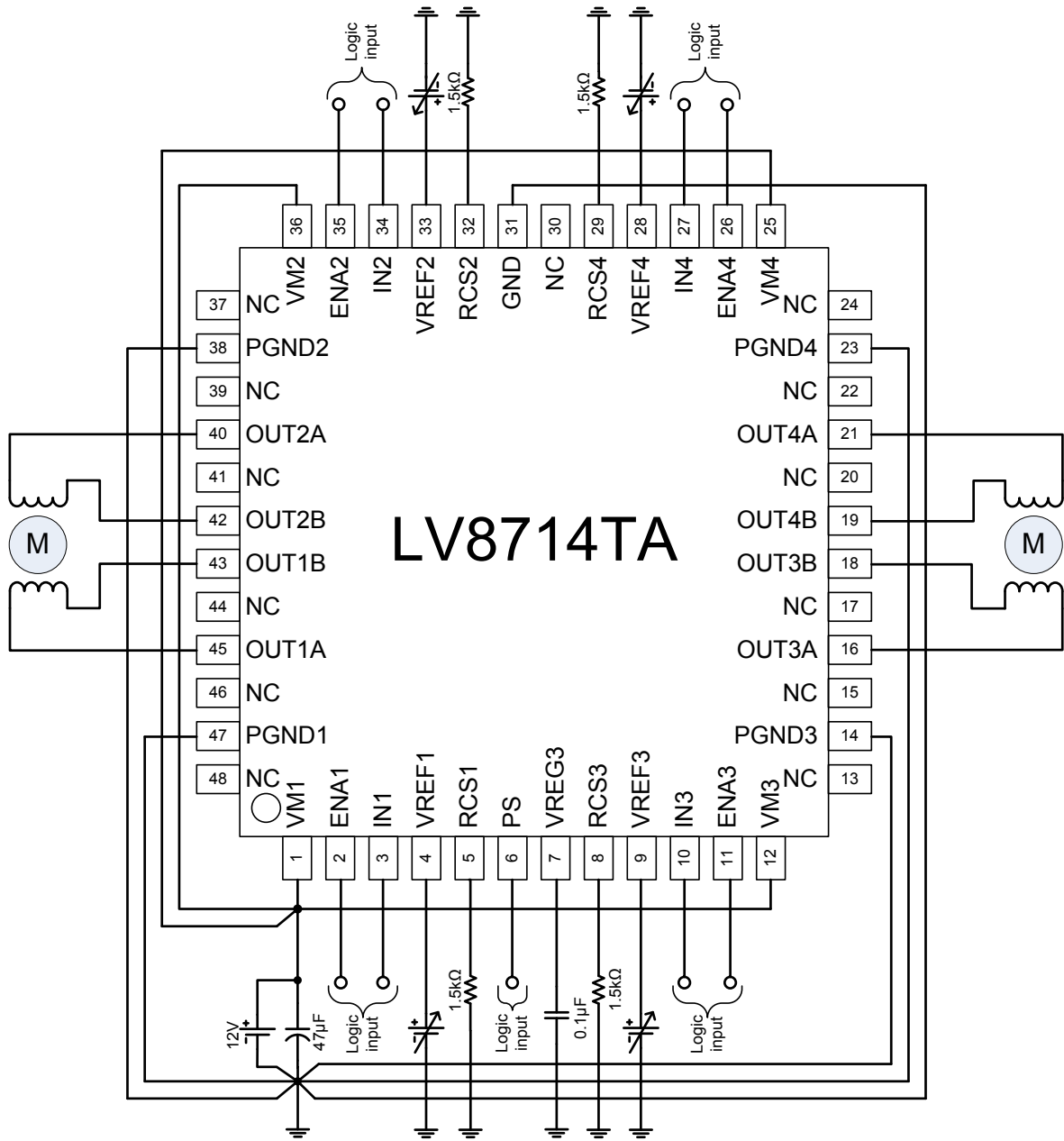

Figure 2. Two Bipolar Stepper motor Drive Using LV8714TA



# LV8714TA

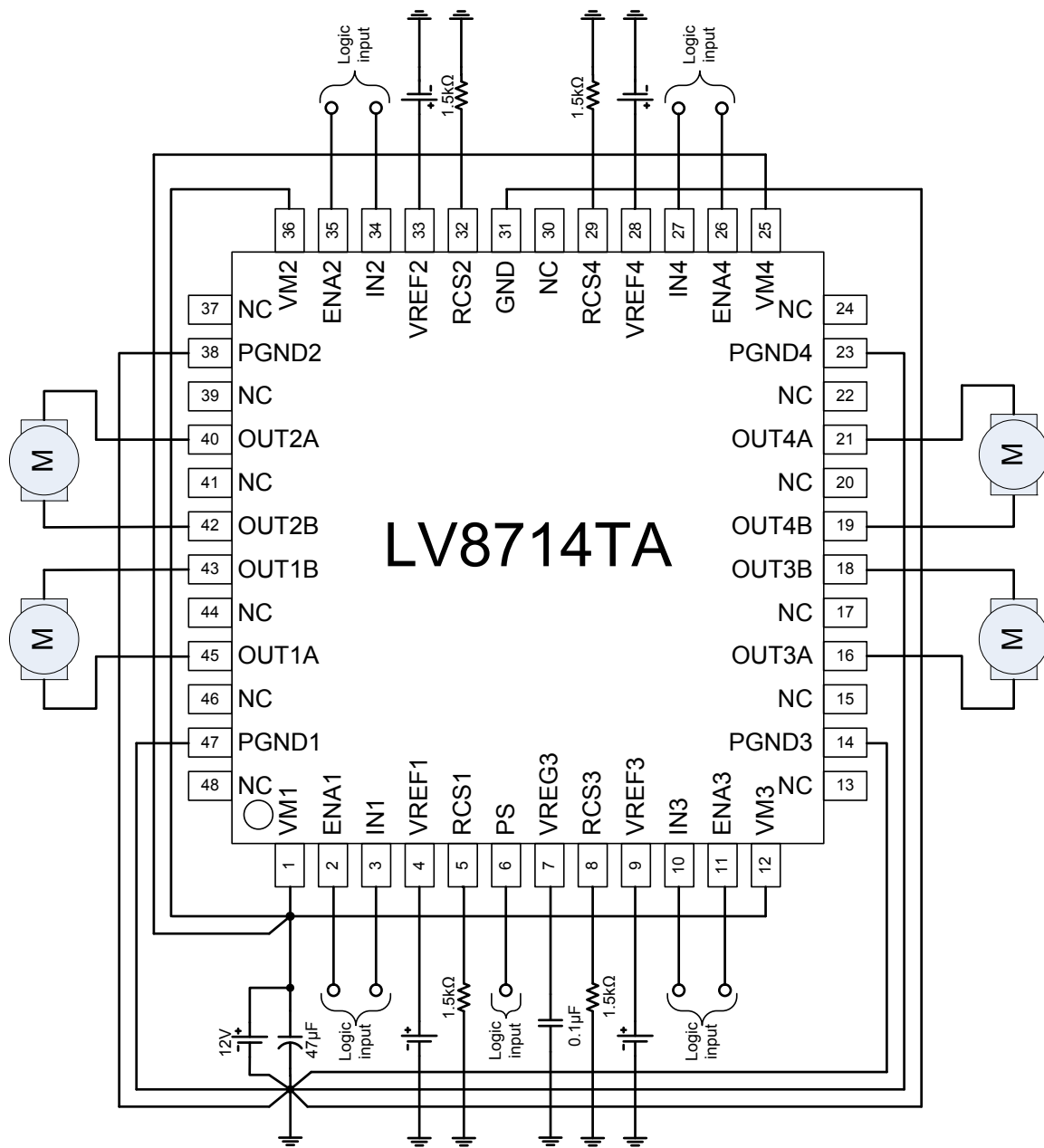

Figure 3. Four Brushed DC motor Drive Using LV8714TA

# LV8714TA

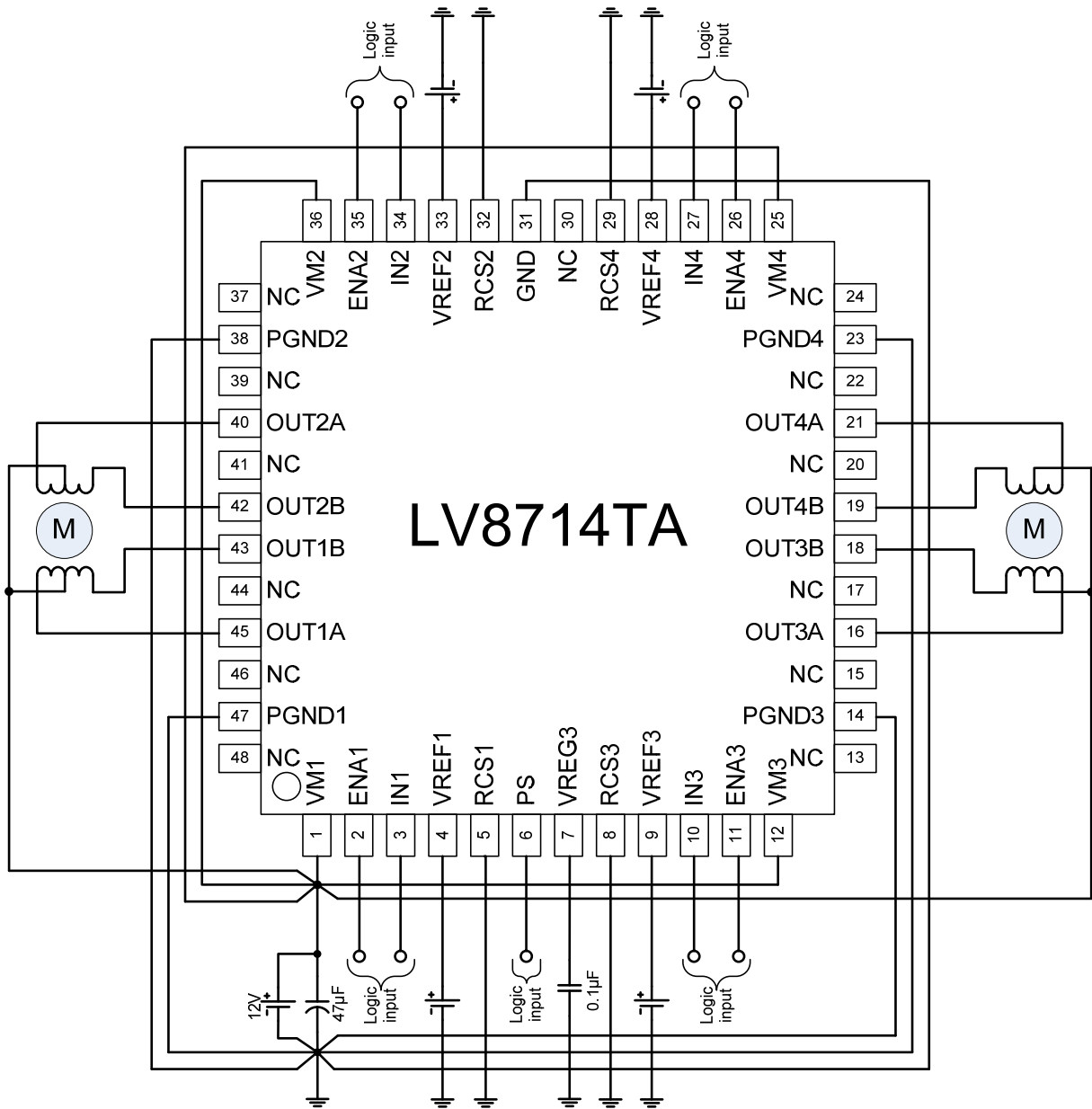

Figure 4. Two Unipolar Stepper motor Drive Using LV8714TA

# LV8714TA

## PIN ASSIGNMENT

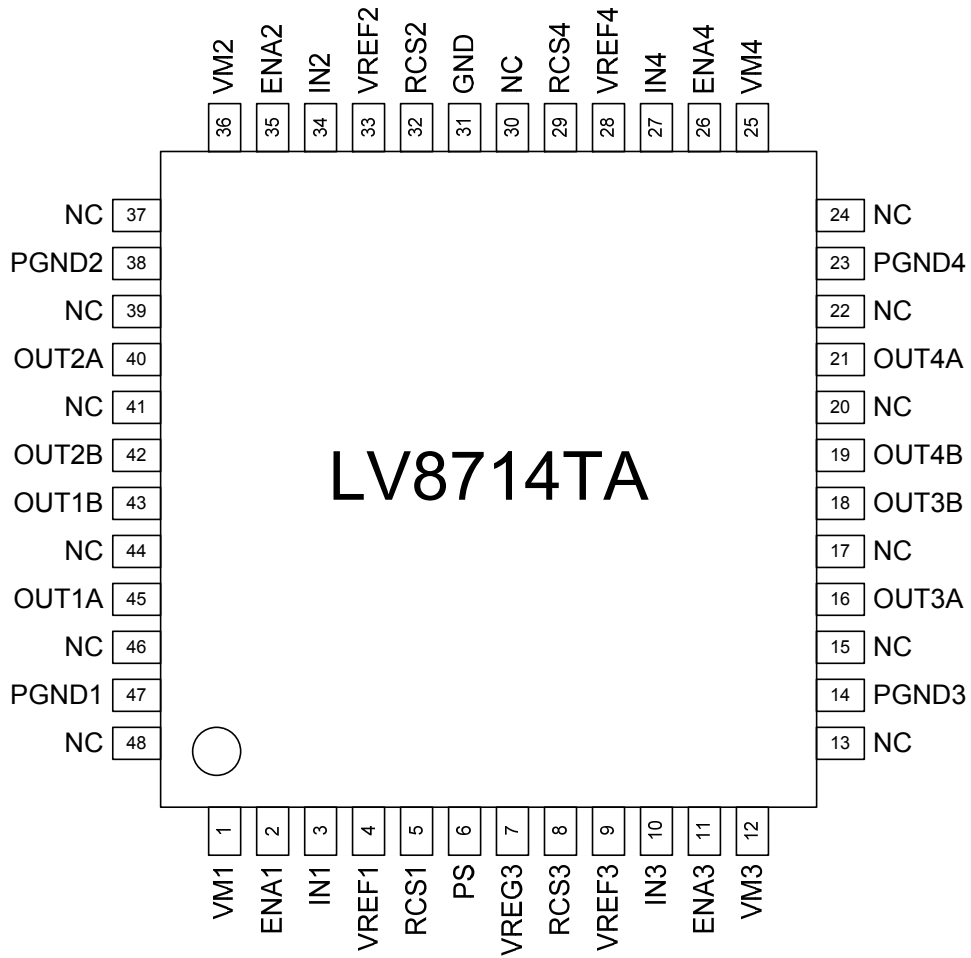

Figure 5. Pin Assignment

# LV8714TA

## PIN FUNCTION DISCRPTION

Pin No.	Pin Name	Description
1	VM1	Motor power supply pin for channel 1
2	ENA1	Enable control pin of channel 1
3	IN1	Input control pin of channel 1
4	VREF1	Reference voltage input pin of channel 1
5	RCS1	Current sense resistor pin of channel 1
6	PS	Power save mode selection pin
7	VREG3	Internal 3.3V voltage regulator pin
8	RCS3	Current sense resistor pin of channel 3
9	VREF3	Reference voltage input pin of channel 3
10	IN3	Input control pin of channel 3
11	ENA3	Enable control pin of channel 3
12	VM3	Motor power supply pin for channel 3
13	NC	No connection
14	PGND3	Channel 3 power ground pin
15	NC	No connection
16	OUT3A	Channel 3 phase output A pin
17	NC	No connection
18	OUT3B	Channel 3 phase output B pin
19	OUT4B	Channel 4 phase output B pin
20	NC	No connection
21	OUT4A	Channel 4 phase output A pin
22	NC	No connection
23	PGND4	Channel 4 power ground pin
24	NC	No connection
25	VM4	Motor power supply pin for channel 4
26	ENA4	Enable control pin of channel 4
27	IN4	Input control pin of channel 4
28	VREF4	Reference voltage input pin of channel 4
29	RCS4	Current sense resistor pin of channel 4
30	NC	No connection
31	GND	Ground pin
32	RCS2	Current sense resistor pin of channel 2
33	VREF2	Reference voltage input pin of channel 2
34	IN2	Input control pin of channel 2
35	ENA2	Enable control pin of channel 2
36	VM2	Motor power supply pin for channel 2
37	NC	No connection
38	PGND2	Channel 2 power ground pin
39	NC	No connection
40	OUT2A	Channel 2 phase output A pin
41	NC	No connection
42	OUT2B	Channel 2 phase output B pin
43	OUT1B	Channel 1 phase output B pin
44	NC	No connection
45	OUT1A	Channel 1 phase output A pin
46	NC	No connection
47	PGND1	Channel 1 power ground pin
48	NC	No connection



# LV8714TA

## MAXIMUM RATINGS (Note 1)

Parameter	Symbol	Value	Unit
Motor Supply Voltage (Note 2)	$V_M$	18	V
Logic Input Voltage (Note 3)	$V_{IN}$	6	V
Output Peak Current per channel (Note 4)	$I_{O(peak)}$	1.75	A
Output current per channel	$I_{O(max)}$	1.5	A
Allowable Power Dissipation (Note 5)	$P_d$	4.86	W
Storage Temperature	$T_{stg}$	-55 to 150	°C
Junction Temperature	$T_J$	150	°C
Moisture Sensitivity Level (MSL) (Note 6)	MSL	3	-
Lead Temperature Soldering Pb-Free Versions (10sec or less) (Note 7)	$T_{SLD}$	260	°C

1. Stresses exceeding those listed in the Absolute Maximum Rating table may damage the device. If any of these limits are exceeded, device functionality should not be assumed, damage may occur and reliability may be affected.
2. Motor power supply pins are VM1, VM2, VM3 and VM4.
3. Logic input pins are PS, ENA1, IN1, ENA2, IN2, ENA3, IN3, ENA4 and IN4.
4. Condition for measuring the output peak current is that total time duration  $\leq 10$  ms (PWM duty cycle = 20%) at each channel.
5. Specified circuit board : 90mm $\times$  90mm $\times$  1.6mm, glass epoxy 4-layer board, with backside mounting. It has 1 oz internal power and ground planes and 1/2 oz copper traces on top and bottom of the board. Please refer to Thermal Test Conditions of page 23.
6. Moisture Sensitivity Level (MSL): 3 per IPC/JEDEC standard: J-STD-020A
7. For information, please refer to our Soldering and Mounting Techniques Reference Manual, SOLDERRM/D  
<http://www.onsemi.com/pub/link/Collateral/SOLDERRM-D.PDF>

## THERMAL CHARACTERISTICS

Parameter	Symbol	Value	Unit
Thermal Resistance, Junction-to-Ambient (Note 5)	$R_{\theta JA}$	25.7	°C/W
Thermal Resistance, Junction-to-Case (Top) (Note 5)	$R_{\psi JT}$	6	°C/W

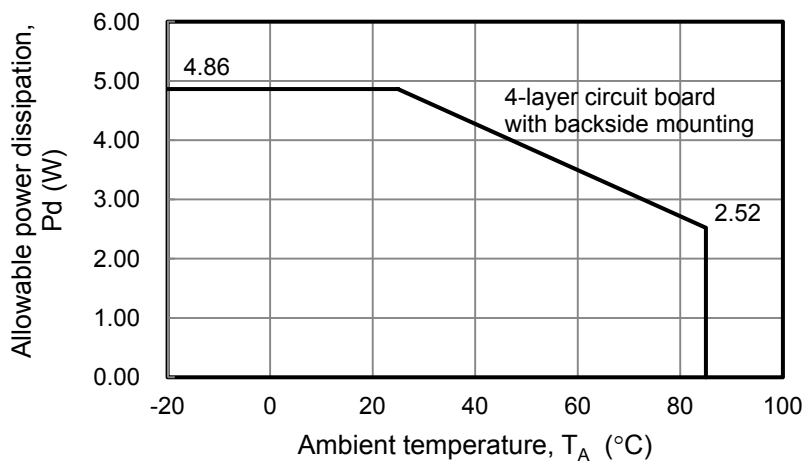

Figure 6. Power Dissipation vs Ambient Temperature Characteristic

# LV8714TA

## RECOMMENDED OPERATING RANGES (Note8)

Parameter	Symbol	Ratings	Unit
Motor Supply Voltage Range (Note 2)	$V_M$	4 to 16.5	V
Logic Input Voltage Range (Note 3)	$V_{IN}$	-0.3 to 5.5	V
VREF Input Voltage Range	$V_{REF}$	0 to 1.5	V
Ambient Temperature	$T_A$	-20 to 85	°C

8. Functional operation above the stresses listed in the Recommended Operating Ranges is not implied. Extended exposure to stresses beyond the Recommended Operating Ranges limits may affect device reliability.

## ELECTRICAL CHARACTERICALS

$T_A=25^{\circ}\text{C}$ ,  $V_M = 12\text{V}$ ,  $V_{REF}=0.6\text{V}$  unless otherwise noted. (Note 9)

Parameter	Symbol	Condition	Min	Typ	Max	Unit
Standby Mode Current	$I_{Mstn}$	$I_{M1}(VM1)+I_{M2}(VM2)+I_{M3}(VM3)+I_{M4}(VM4)$ , PS="L", No load		0	1	$\mu\text{A}$
Supply Current	$I_M$	$I_{M1}(VM1)+I_{M2}(VM2)+I_{M3}(VM3)+I_{M4}(VM4)$ , PS="H", No load		3.2	4.2	mA
Thermal Shutdown Temperature	TSD	Guaranteed by design	150	180		°C
Thermal hysteresis width	$\Delta\text{TSD}$	Guaranteed by design		40		°C
Regulator						
REG3 Output Voltage	$V_{REG3}$		3	3.3	3.6	V
Output						
Output On Resistance	$R_{onU}$	$I_O=-1.5\text{A}$ , Upper side		0.6	0.85	$\Omega$
	$R_{onL}$	$I_O=1.5\text{A}$ , Lower side		0.3	0.5	$\Omega$
Output leakage current	$I_{Oleak}$	$V_M=16.5\text{V}$			10	$\mu\text{A}$
Diode forward voltage	$V_F$	$I_F=-1.5\text{A}$		1.2	1.6	V
Logic Input						
Logic Pin Input Current	$I_{INL}$	PS,ENA1,IN1,ENA2,IN2,ENA3,IN3,ENA4,IN4, $V_{IN}=0.8\text{V}$	4.8	8	13.3	$\mu\text{A}$
	$I_{INH}$	PS,ENA1,IN1,ENA2,IN2,ENA3,IN3,ENA4,IN4, $V_{IN}=3.3\text{V}$	20	33	55	$\mu\text{A}$
Logic Input Voltage	High	$V_{INH}$	2.0		5.5	V
	Low	$V_{INL}$	0		0.8	V
PWM Current Control						
VREF Pin Input Current	$I_{REF}$	$V_{REF1},V_{REF2},V_{REF3},V_{REF4}$ $V_{REF}=1.5\text{V}$	-0.5			$\mu\text{A}$
Current Detection Reference Voltage	$V_{REFdet}$	$V_{REF1},V_{REF2},V_{REF3},V_{REF4}$ $V_{REF}=0.6\text{V}$	0.18	0.2	0.22	V
PWM (Chopping) Frequency	Fchop		100	125	150	kHz
Output current detection current	Ircs	RCS1,RCS2,RCS3,RCS4, $I_o=0.5\text{A}$ ,RSC=0V	115	125	137	$\mu\text{A}$

9. Product parametric performance is indicated in the Electrical Characteristics for the listed test conditions, unless otherwise noted. Product performance may not be indicated by the Electrical Characteristics if operated under different conditions.

## TYPICAL CHARACTERISTICS

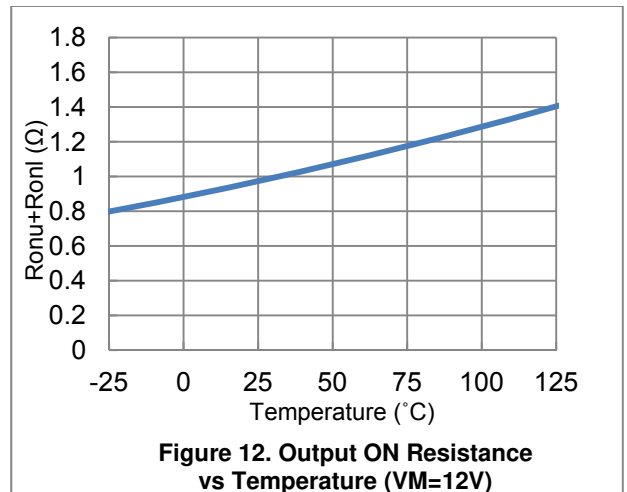
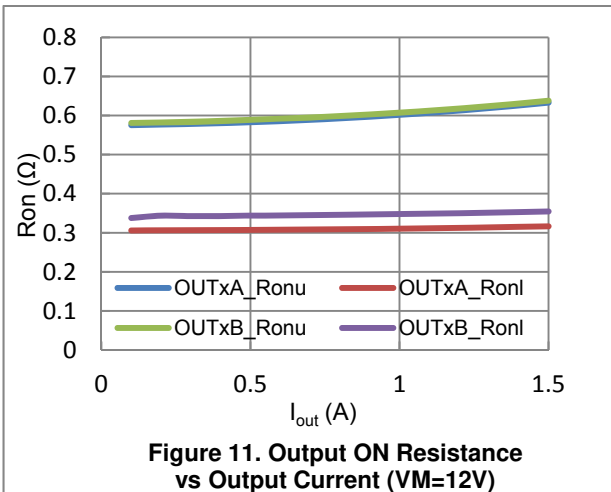
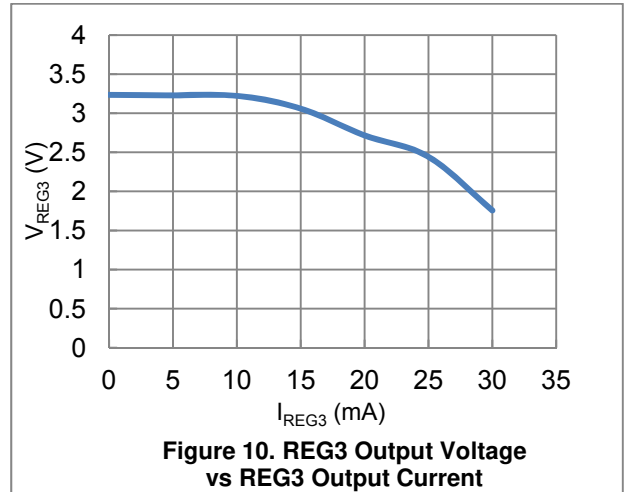
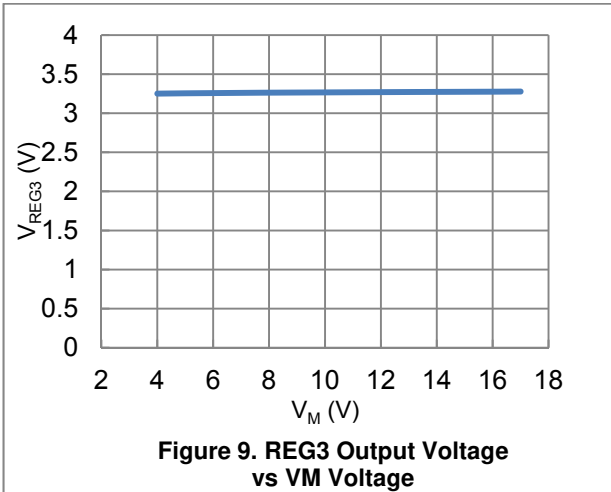
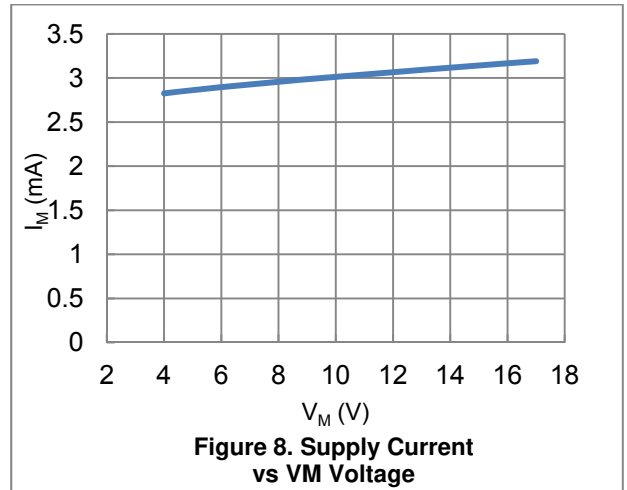
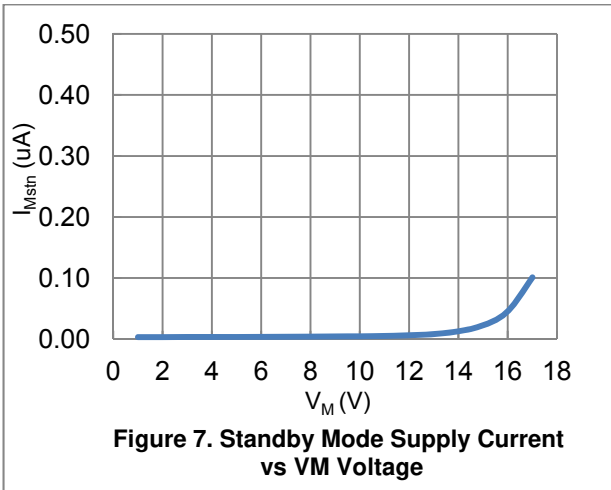

TYPICAL CHARACTERISTICS

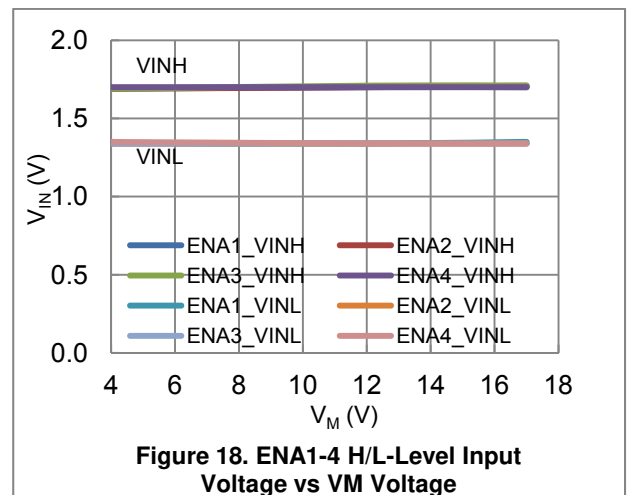
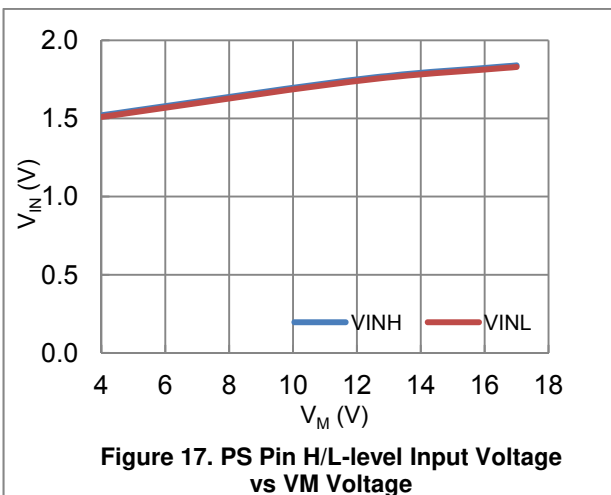
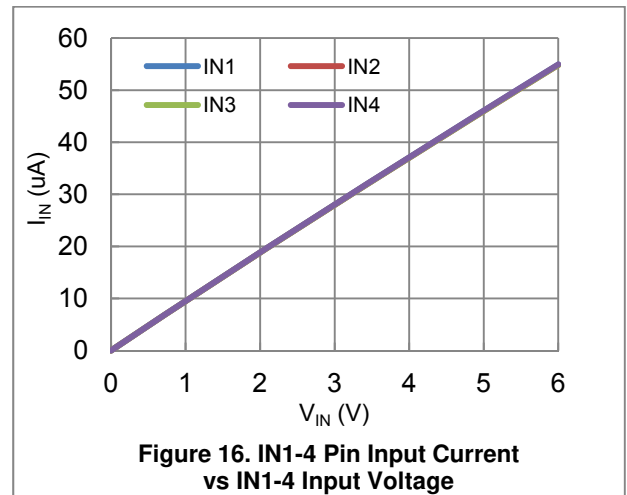
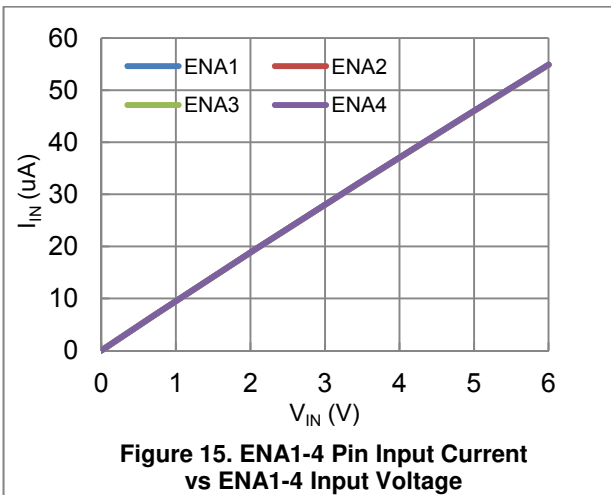
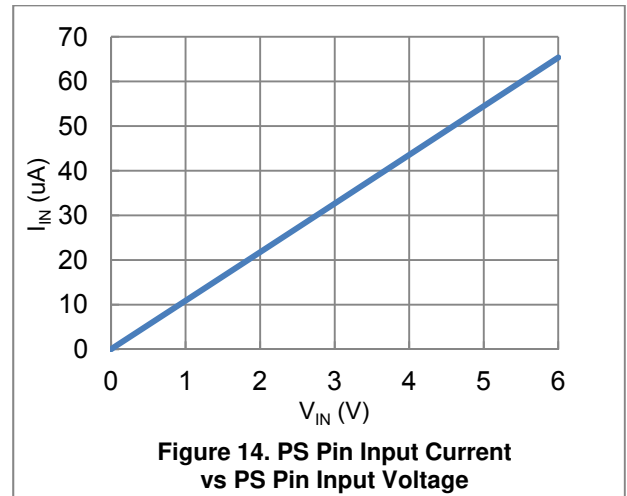
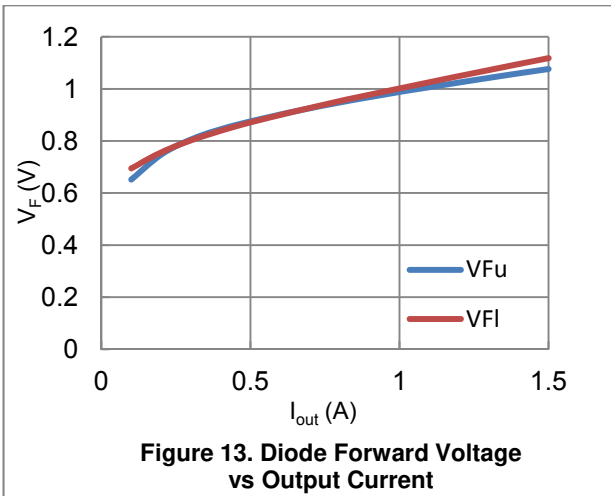

TYPICAL CHARACTERISTICS

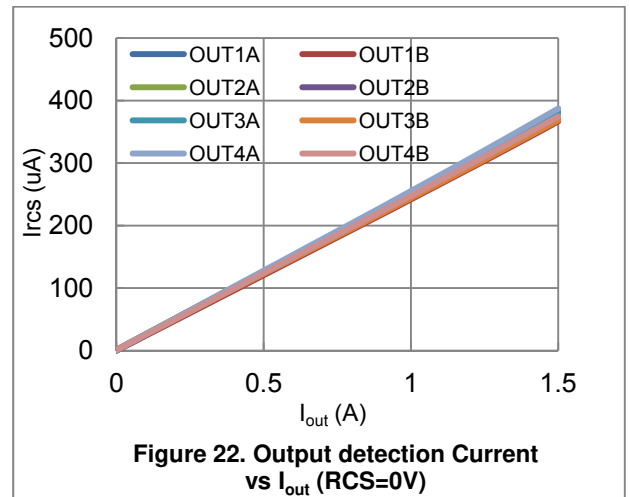
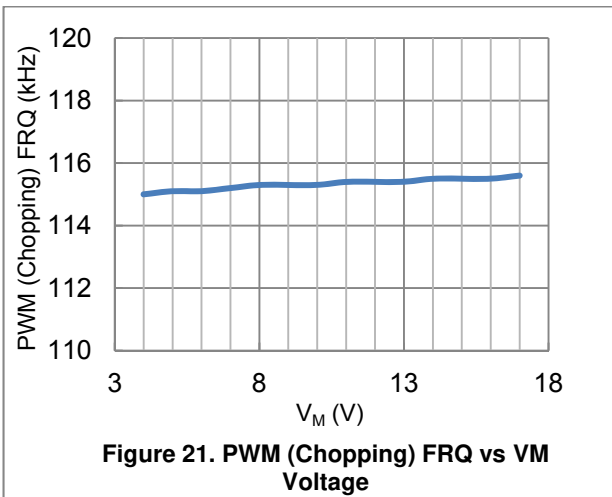
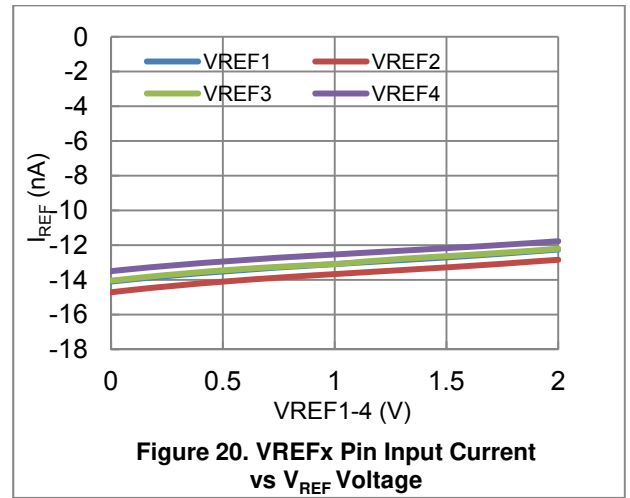
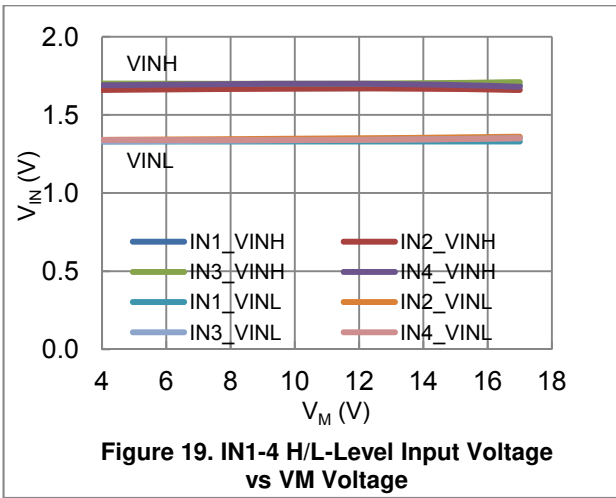

## FUNCTIONAL DESCRIPTION

### Power Supply Pins (VM1, VM2, VM3 AND VM4)

The LV8714 has four power supply pins, VM1, VM2, VM3, and VM4, connected internally. Hence, it is must that all power supply pins are connected to the same power supply rail externally. VM1 also supplies power to internal circuits through an internal voltage regulator.

It is highly recommended to provide a decoupling capacitor of 47µF close to the VM1 pin.

### Internal 3.3V Voltage Regulator Pin (VREG3)

An internal 3.3V voltage regulator acts a power source for internal logic, oscillator, and protection circuits. Output of this regulator is connected to the VREG3 pin. Do not use the VREG3 pin to drive any external load. It is recommended to connect a 0.1µF decoupling capacitor to the VREG3 pin.

### Internal Regulator (VM-3.3V)

An VM-3.3V regulator is integrated in the LV8714. This regulator provides required biasing for upper MOSFETs of each channel.

### Power Save Mode Selection Pin (PS)

When the LV8714 is idle, to save power, it can be put to a power saving, Standby mode by applying logic low to the PS pin. While in the Standby mode, all internal circuits of the LV8714 including voltage regulators are put into inactive state. Table 1 shows mode selection of the LV8714 using the PS pin

Logic Input at PS Pin	Mode	Internal Circuits
Low or Open	Standby	Inactive
High	Operating	Active

**Table 1: LV8714 mode selection using the PS pin**

Figure 23 shows an equivalent internal circuit of the PS pin input.

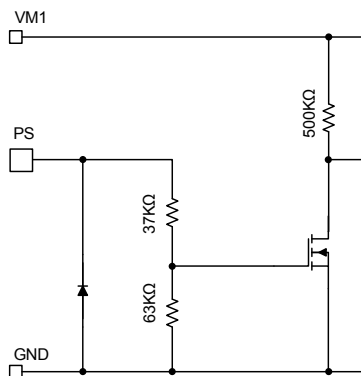

**Figure 23. Equivalent circuit of the PS pin**

### Channel Control Pins (ENAx, INx)

Each channel of the LV8714 is controlled independently by corresponding ENAx and INx pins. Figure 24 shows an equivalent internal circuit of these input pins.

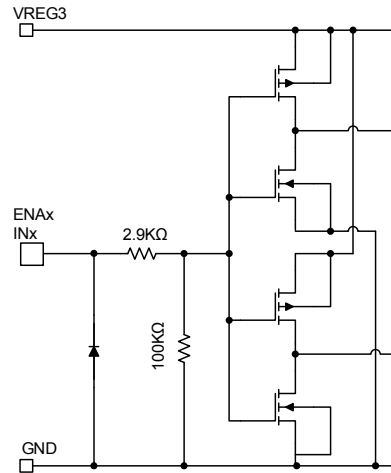

**Figure 24. Equivalent circuit of ENAx, INx**

### Motor Drive Output Pins (OUTxx)

The LV8714 has quad built-in H-bridges for driving stepper or DC motors. Each H-bridge (channel) is made up of upper side P-MOSFETs and lower side N-MOSFETs. Output of each channel is connected to OUTxA or OUTxB pins. When a channel is configured to drive a stepper motor in forward direction, OUTxA becomes high output and in reverse direction, OUTxB becomes high output.

### Reference Voltage Input Pins (VREFx)

Step size of a stepper motor drive is controlled by providing a reference voltage signal at VREFx pin for each channel. Resolution of the VREFx input enables ultra-small micro step drive of a stepper motor in combination with the INx input. The coil current is proportional to the analog voltage amplitude at the VREFx pin.

Figure 25 shows an equivalent circuit of VREFx input pins.

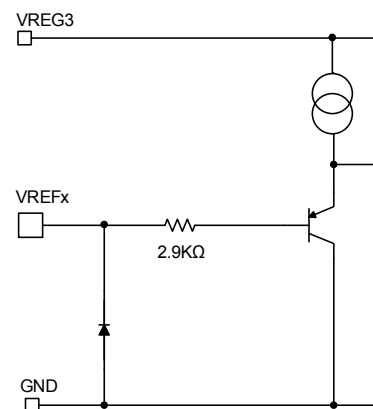

**Figure 25. Equivalent circuit of VREF1-4**

### Current Sense Resistor Pins (RCSx)

The LV8714 implements a proprietary current sense mechanism for each channel and doesn't require any external current sense power resistor, thus providing

loss-less current control that improves the energy efficiency of the system.

To control a coil current, the individual RCSx pin is provided for each channel. A resistor connected at this RCSx pin decides the coil current. The coil current is sensed internally and fed back to RCS pin with the ratio of 1/4000. And, the output duty cycle adjusted such that the RCSx voltage level is equal to 1/3 of the VREFx pin voltage. Figure 26 shows the equivalent circuit of current control.

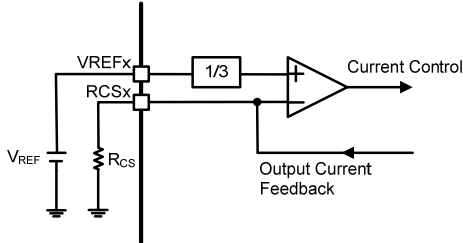

**Figure 26. Equivalent circuit of current control**

Equation 1 is utilized to calculate the coil current,  $I_{OUT}$ .

$$\frac{I_{OUT}}{4000} \cdot R_{CS} = \frac{V_{REF}}{3} \dots \dots \dots (1)$$

Where,

$I_{OUT}$  = Coil current [A]

$R_{CS}$  = Resistance between RCSx and GND [ $\Omega$ ]

$V_{REF}$  = Input voltage at the VREFx pin [V]

For example, in case of

$$R_{CS} = 1k\Omega$$

$$V_{REF} = 0.6V$$

The coil current is

$$I_{OUT} = \frac{4000 \times 0.6}{3 \times 1000} = 0.8A$$



# LV8714TA

## DETAILED DESCRIPTION

### Stepper Motor Direction Control

The stepper motor rotation direction is determined by phase lead/lag relation between INx inputs of the LV8714 as shown in Table 2 and Table 3.

INx	ENA1, ENA2	Phase				Direction
		0-90	90-180	180-270	270-360	
IN1	H	L	L	H	H	Forward
IN2	H	H	L	L	H	
IN1	H	H	L	L	H	Reverse
IN2	H	L	L	H	H	

**Table 2: Stepper Motor Direction control by IN1 and IN2**

INx	ENA3, ENA4	Phase				Direction
		0-90	90-180	180-270	270-360	
IN3	H	L	L	H	H	Forward
IN4	H	H	L	L	H	
IN3	H	H	L	L	H	Reverse
IN4	H	L	L	H	H	

**Table 3: Stepper Motor Direction control by IN3 and IN4**

### DC Motor Direction Control

The LV8714 utilizes ENAx and INx to control the DC motor rotation direction as shown in Table 4.

Input signal		Output		Direction
ENAx	INx	OUTxA	OUTxB	
L	–	Off	Off	
H	L	High	Low	Forward
H	H	Low	High	Reverse

X represents a channel number

**Table 4: DC Motor Direction Control by ENAx and INx**

### Stepper Motor Coil Current Control

Stepper motor coil current is controlled in proportional to VREFx and RCSx as shown in equation 1 previously. Two phase outputs (A and B) for each stepper motor are controlled by combination of INx and VREFx inputs as shown in Table 5.

Input			Output (coil current)	
INx	VREFx	ENAx	Amplitude	Polarity
Low	Analog	High	Proportional to VREFx	A to B
High	Analog	High	Proportional to VREFx	B to A

**Table 5: Stepper Motor Coil Current Control**

Figure 27 and 28 show example waveforms of output current with in response to VREFx, ENAx and INx input.

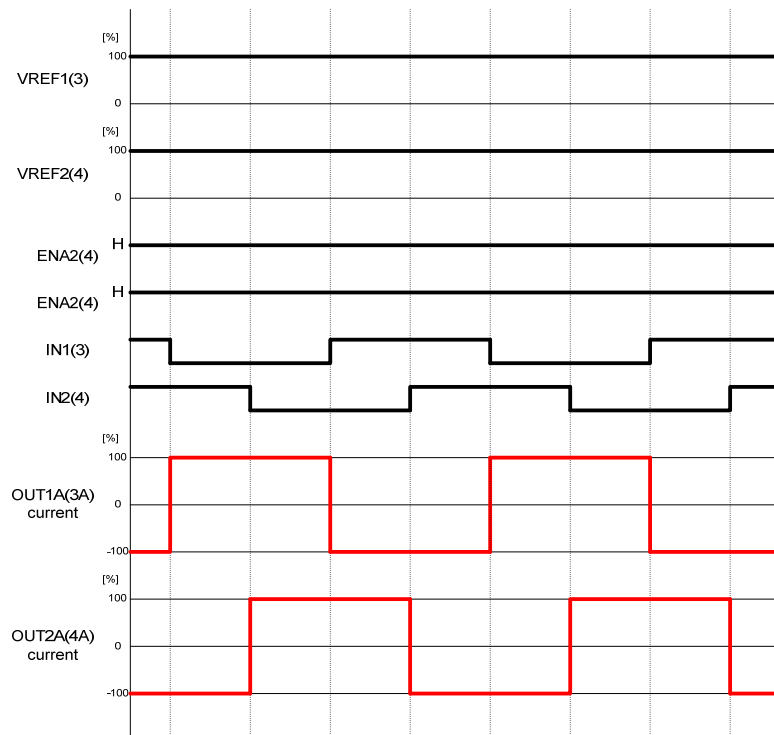

**Figure 27. Example waveforms for full step (forward) control**

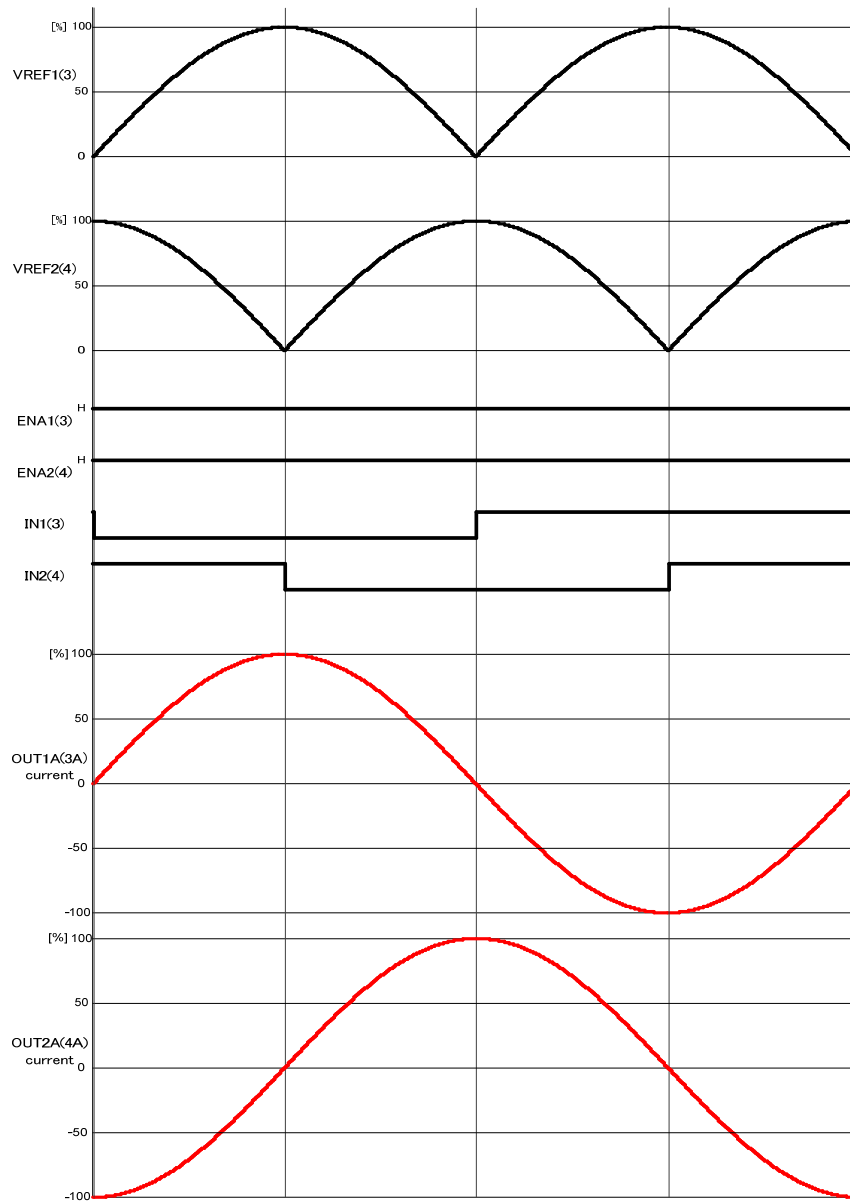

Figure 28. Example waveforms for 1/256 step (forward) control

**PWM Constant-Current Control**

The LV8714 implements constant-current control drive by applying PWM switching to the output pin.

When the coil current becomes equal to the set target value (as determined by equation 1), the constant current control mechanism gets activated and performs a repetitive sequence of Charge → Slow Decay → Fast Decay (fixed 2μs) → Charge... as shown in Figure 29. The period for each sequence is fixed at 8μs(typ.).

Figure 29 shows timing chart of PWM based constant-current control.

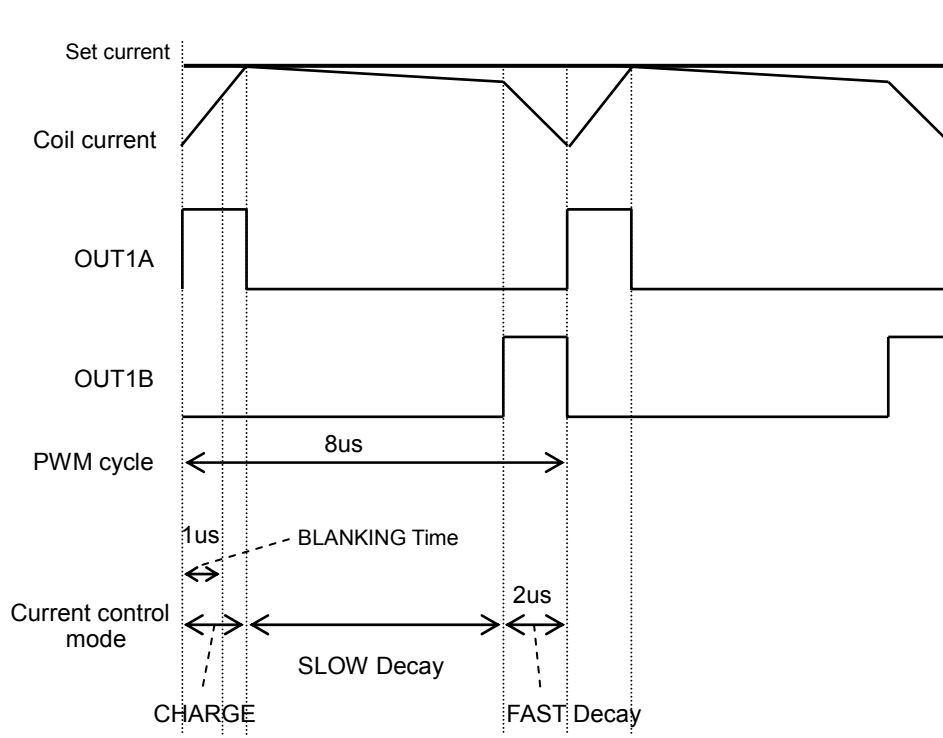

Figure 29. Timing chart of PWM based constant-current

**Three Modes of Constant-Current Control**

Each PWM cycle of constant-current control is made up of three distinct intervals – Charge, Slow Decay and Fast Decay.

Example: Current direction A to B

**Charge:**  
Voltage is applied to the coil until the coil current becomes equal to the target (A = High, B = Low).

**Slow Decay:**  
Output A and B are shorted internally resulting in circular current (A = Low, B = Low).

**Fast Decay:**  
Inverted bias is applied to discharge the coil current (A = Low, B = High) that results in decreases of the coil current.

These intervals (Charge, Slow Decay and Fast Decay) are results of MOSFET switching as shown in Figure 30.

# LV8714TA

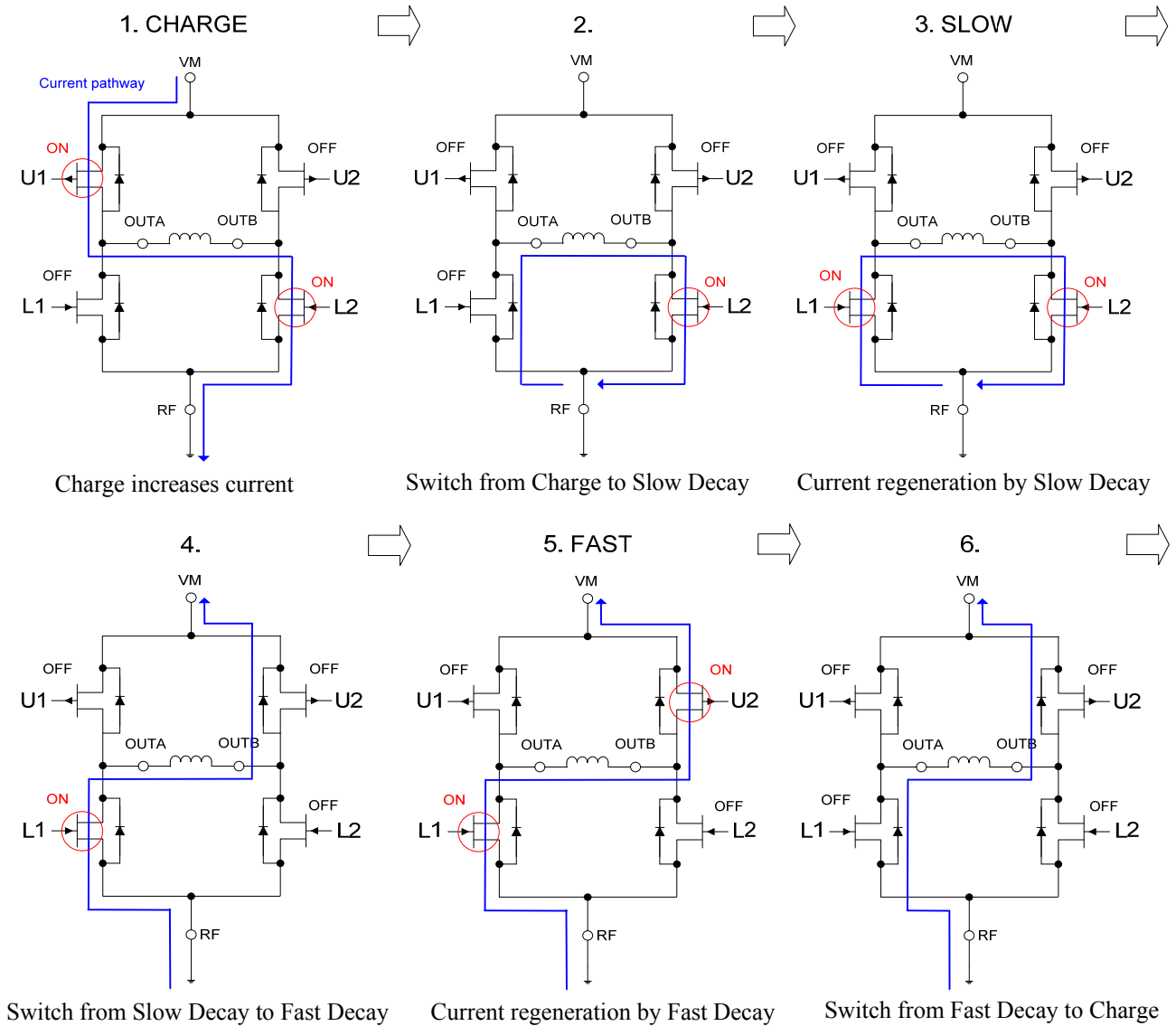

Figure 30. MOSFET switching sequence for constant-current control

Whenever, there is a switch from the upper MOSFET to the lower MOSFET of the same leg, the fixed dead time of  $0.375\mu\text{s}$  is provided to avoid turning on both MOSFETs on at the same time. During this time, the coil current flows through the body diode of the MOSFET as seen in (2), (4) and (6) events in figure 30.

Table 6 and Table 7 show status of MOSFETs during various intervals in a PWM cycle for different current polarities.

OUTxA→OUTxB

Output Tr	CHARGE	SLOW Decay	FAST Decay
U1	ON	OFF	OFF
U2	OFF	OFF	ON
L1	OFF	ON	ON
L2	ON	ON	OFF

Table 6: MOSFET Switching Sequence for OUTxA→OUTxB polarity

OUTxB→OUTxA

Output Tr	CHARGE	SLOW Decay	FAST Decay
U1	OFF	OFF	ON
U2	ON	OFF	OFF
L1	ON	ON	OFF
L2	OFF	ON	ON

Table 7: MOSFET Switching Sequence for OUTxB→OUTxA polarity

Figure 31 shows example waveforms of the stepper motor with 1/16 step and constant-current control.

Figure 32 shows example waveforms of three events – Charge, Slow Decay and Fast Decay.

# LV8714TA

**1/16 step**  
 VM=12V  
 VREF1/2=0.23V  
 (Iout≈0.2A)  
 RCS1/2=1.5kΩ  
 IN1=IN2≈ 125Hz  
 Rcoil=15Ω

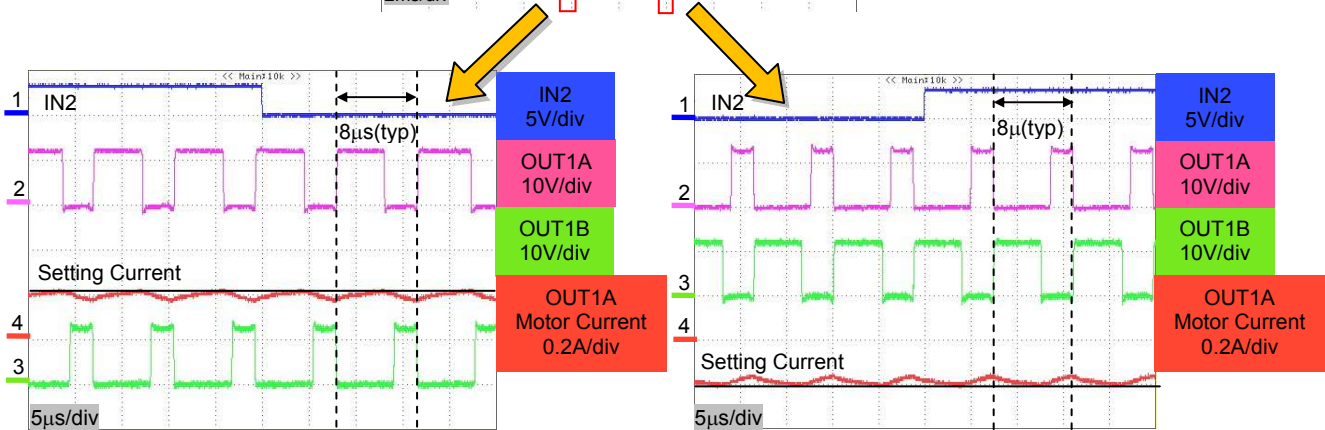
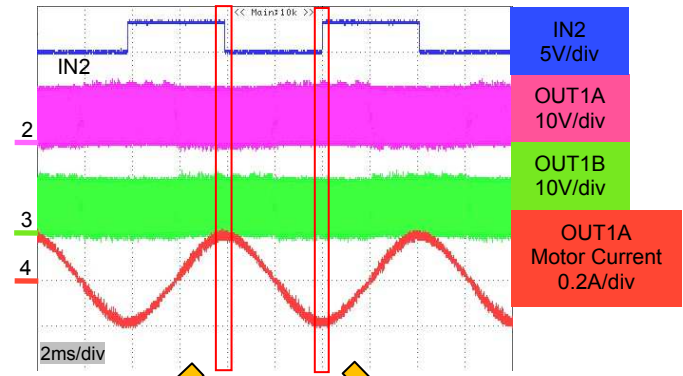
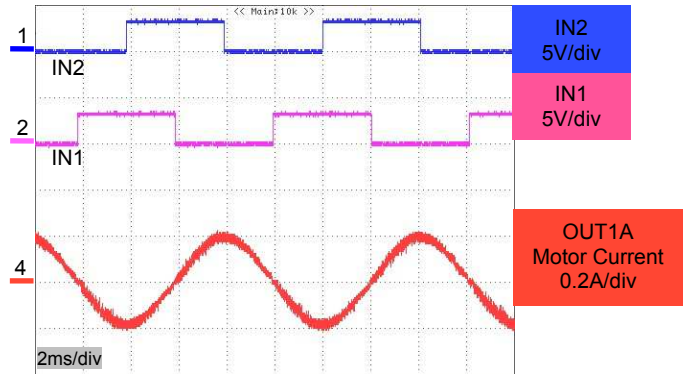

Constant current control is synchronized to the internal PWM period 8µs (typ).

**Figure 31. PWM based constant-current control waveforms of the stepper motor with 1/16 step**

VM=12V  
 VREF1/2=0.11V  
 (Iout≈0.1A)  
 RCS1/2=1.5kΩ  
 IN1=IN2=100Hz  
 Rcoil=15Ω

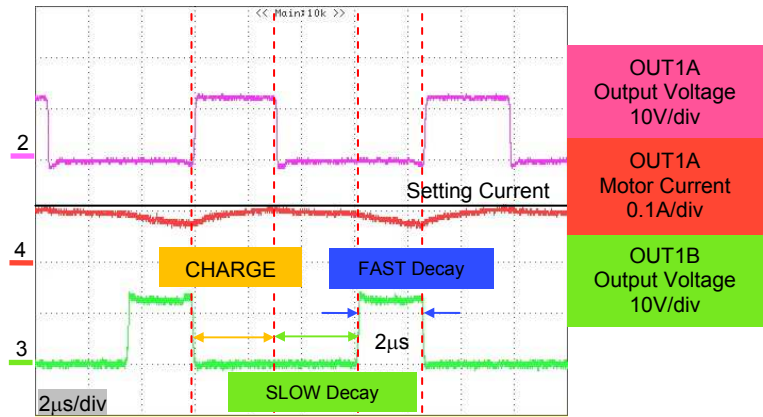

**Figure 32. One full PWM cycle of the constant-current control**

**Blanking Time**

As the LV8714 switches from Fast Decay to Charge, switching noise can lead to wrong reading by the comparator that is comparing the coil current against the target current. To filter out this switching noise, a fixed 1μs blanking time is provided at the beginning of the Charge interval.

During this blanking time, the comparator ignores the coil current reading and thus avoid false switching to the Slow Decay interval, if the comparator detects the coil current higher than the target current.

**Power-on Reset (POR) Sequence**

At startup, when  $VM1 \geq 4V$  and  $PS = High$ , it takes 50μs for the internal 3.3V regulator to provide stable output. After the 3.3V regulator is in the active state, ENAx needs to be pulled high to enable respective channel output. It is recommended that VREFx input is never floating and the required input signal is applied at least 10μs before ENAx is pulled high. Figure 33 shows POR and fault handling sequence.

POR and Fault Handling Operation Flow

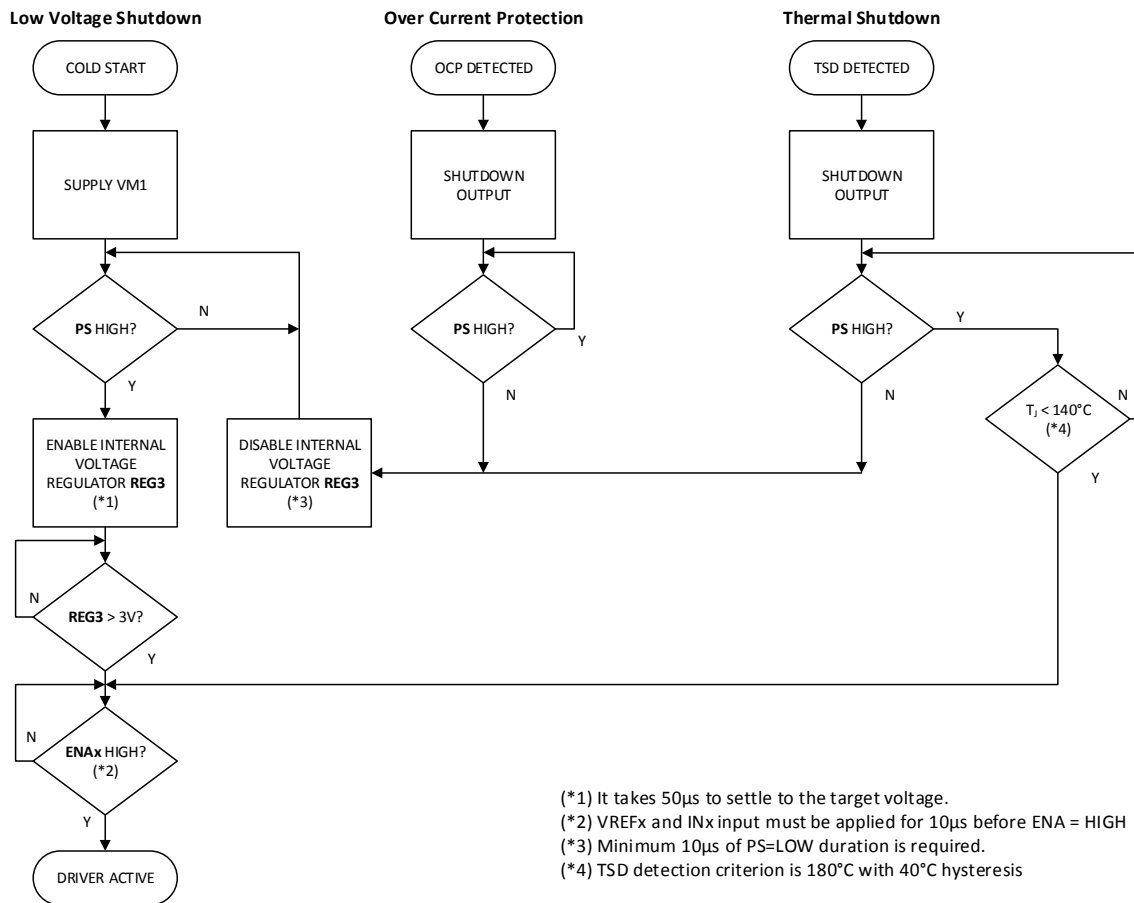

Figure 33. POR and fault handling sequence

**System Protection Functions**

The LV8714 has built-in protection functions such as over-current (OCP), over-temperature (Thermal shutdown, TSD), and under-voltage (Low-voltage shutdown, LVS) protections. These integrated

protections make the LV8714 based system solution highly reliable without need for any external protection circuit. Table 8 shows summary of LV8714 protection functions with recovery mechanisms.

Priority	Fault Event	Condition	OUTxx	Logic	Regulator	Recovery
1	Low Voltage Shutdown LVS	VREG3 < 2.6V	OFF	Reset	< 2.6V	VM1 ≥ 4.0V
2	Thermal Shutdown TSD	Junction temperature > 180°C	OFF	Active	ON	Auto-recover when Tj ≤ 140°C
3	Over-current Protection OCP	Upper side FET current > 2.6A Lower side FET current > 2.0A	OFF	Active	ON	Toggle PS input High → Low (≥10μs) → High

Table 8: Summary of LV8714 protection functions with recovery mechanisms

# LV8714TA

## Low Voltage Shutdown (LVS)

The integrated LVS protection enables safe shutdown of the system when the VM1 drops. The VREG3 voltage is monitored and the LVS is activated when the VREG3 voltage drops below 2.6V (typ.). It turns off output FETs and logic circuits are put into the reset state. The LV8714 recovers from the LVS automatically when  $VM1 \geq 4V$ .

## Thermal Shutdown (TSD)

The built-in TSD protection prevents damage to the LV8714 from excessive heat. To avoid false trigger, the TSD protection is activated when the die  $T_J$  exceeds 180°C. Once activated, it shuts down output FETs while keeping the rest of circuit in the active state. When  $T_J$

falls below 140°C, the output stage is reactivated under control of input signals INx, and ENAx.

## Over-current Protection (OCP)

The on-chip OCP protection of the LV8714 triggers when current above the threshold is detected internally. Once detected for 2 $\mu$ s, output FETs are turned off and the internal timer is triggered to count 128 $\mu$ s (typ.) of the timer latch period. At the end of the timer latch period, output FETs are turned on again 2 $\mu$ s. If during this time, over-current is detected again, then the fault is latched and FETs are turned off. FETs can now be turned on again only when over-current condition is removed and the PS pin is toggled (High  $\rightarrow$  Low ( $\geq 10\mu$ s)  $\rightarrow$  High). Timing chart of the OCP is as shown in Figure 34.

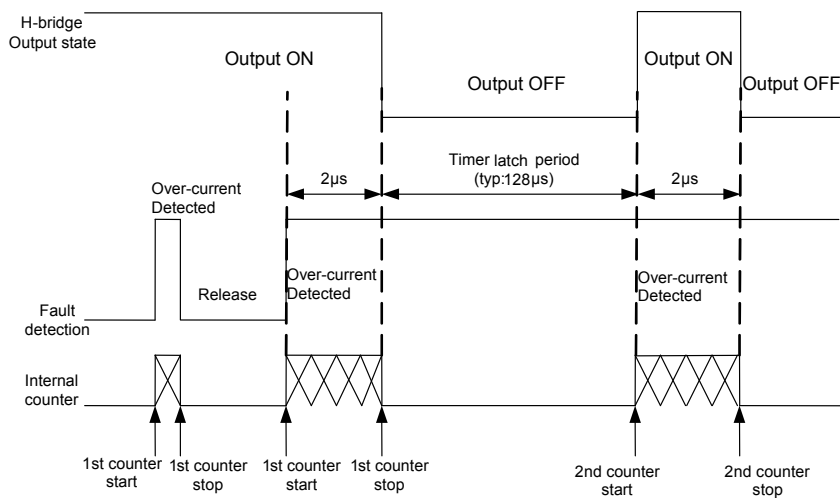
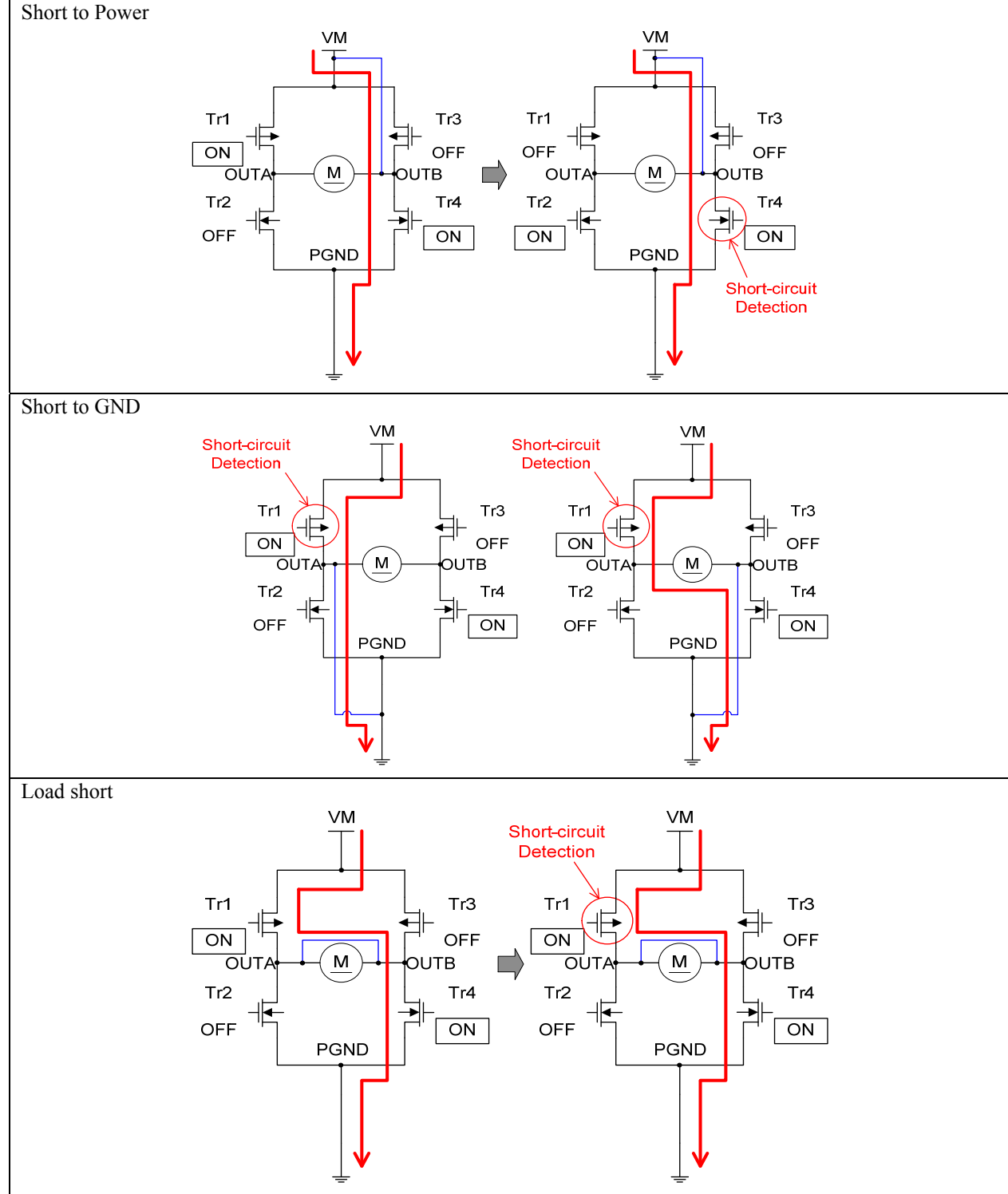

Figure 34. Timing Chart of OCP



Example of Over-current Detection:



**PCB GUIDELINES**

**VM and Ground Routing**

Make sure to short-circuit VM1, VM2, VM3 and VM4 externally by a low impedance route on one side of PCB. As high current flows into PGND, connect it to GND through a low impedance route.

**Exposed Pad**

The exposed pad is connected to the frame of the LV8714. Therefore, do not connect it to anywhere else other than ground. If GND and PGND are in the same plane, connect the exposed pad to the ground plane. Else, if GND and PGND are separated, connect the exposed pad to GND.

**NC Pin Utilization**

NC pins are not connected internally inside the LV8714. If the power track that is connected to VM, outputs and GND is wide, the power track can be connected to NC pins.

**Thermal Test Conditions**

Size: 90mm × 90mm × 1.6mm (four layer PCB)

Material: Glass epoxy

Copper wiring density: L1 = 80% / L4 = 85%

Second layer is VM power supply layer.

Third layer is GND layer

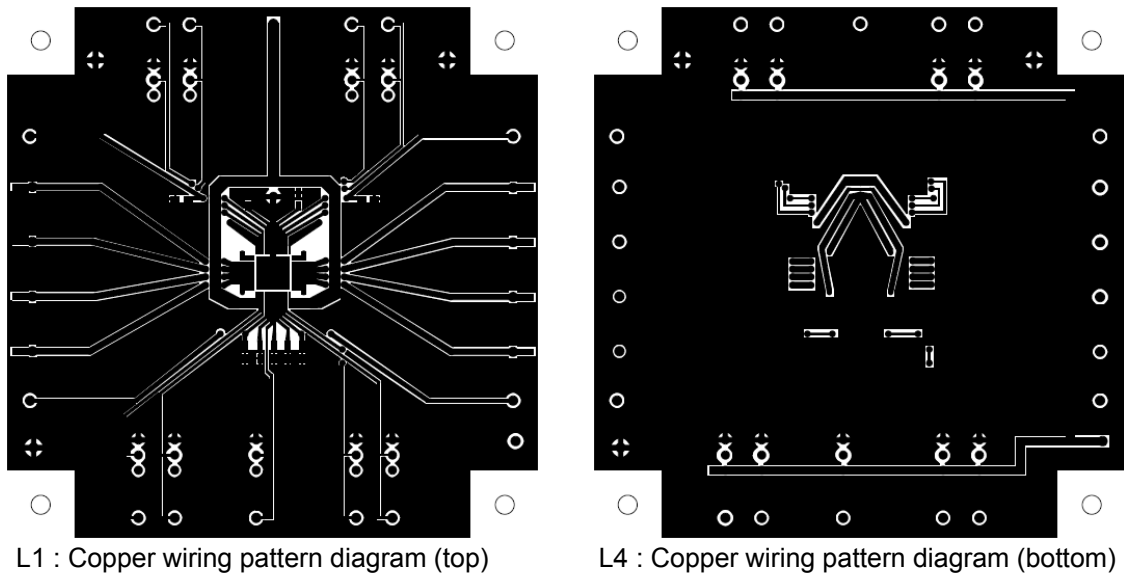

**Figure 35. Pattern Diagram of Top and Bottom Layer**

**Recommendation**

The thermal data provided is for the thermal test condition where 90% or more of the exposed die pad is soldered.

It is recommended to derate critical rating parameters for a safe design. Electrical parameters that are recommended to be derated are operating voltage, operating current, junction temperature, and device power dissipation. The recommended derating for a safe design is as shown below:

- Maximum 80% or less for operating voltage

- Maximum 80% or less for operating current
- Maximum 80% or less for junction temperature

Check solder joints and verify reliability of solder joints for critical areas such as exposed die pad, power pins and grounds.

Any void or deterioration, if observed, in solder joint of these critical areas parts, may cause deterioration in thermal conduction and that may lead to thermal destruction of the device.

# LV8714TA

## PACKAGE DIMENSIONS

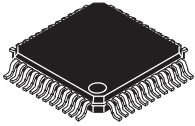

TQFP48 EP 7x7, 0.5P  
CASE 932F  
ISSUE C

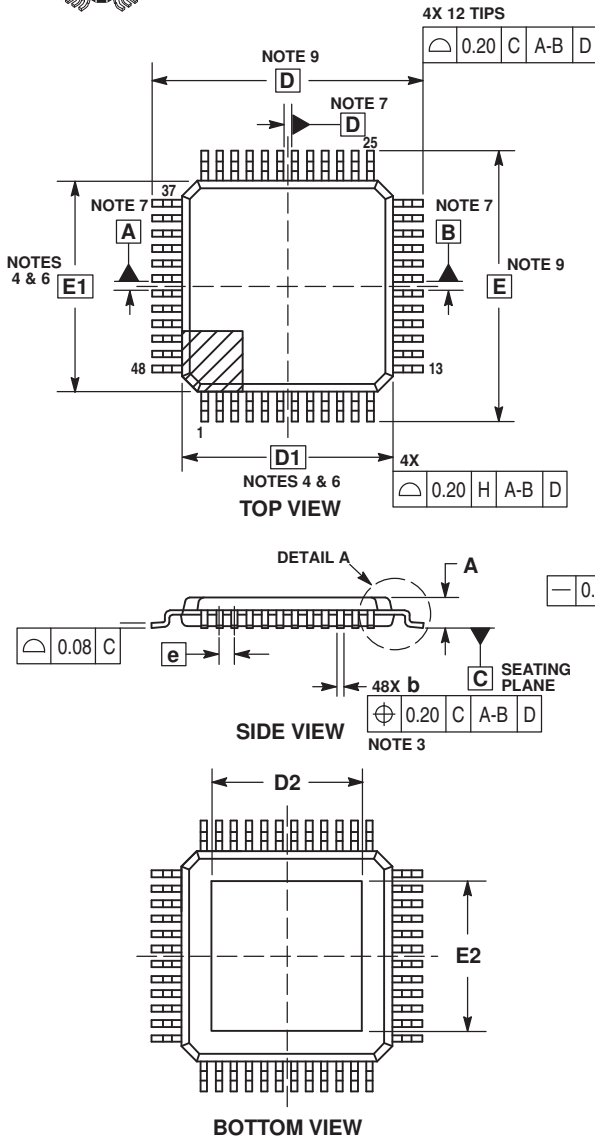

NOTES:

1. DIMENSIONS AND TOLERANCING PER ASME Y14.5M, 1994.
2. CONTROLLING DIMENSION: MILLIMETERS.
3. DIMENSION b DOES NOT INCLUDE DAMBAR PROTRUSION. DAMBAR PROTRUSION SHALL BE 0.08 MAX. AT MMC. DAMBAR CANNOT BE LOCATED ON THE LOWER RADIUS OF THE FOOT. MINIMUM SPACE BETWEEN PROTRUSION AND ADJACENT LEAD IS 0.07.
4. DIMENSIONS D1 AND E1 DO NOT INCLUDE MOLD FLASH, PROTRUSIONS OR GATE BURRS. MOLD FLASH, PROTRUSIONS OR GATE BURRS SHALL NOT EXCEED 0.25 PER SIDE. DIMENSIONS D1 AND E1 ARE MAXIMUM PLASTIC BODY SIZE INCLUDING MOLD MISMATCH.
5. THE TOP PACKAGE BODY SIZE MAY BE SMALLER THAN THE BOTTOM PACKAGE SIZE BY AS MUCH AS 0.15.
6. DATUMS A-B AND D ARE DETERMINED AT DATUM PLANE H.
7. A1 IS DEFINED AS THE VERTICAL DISTANCE FROM THE SEATING PLANE TO THE LOWEST POINT ON THE PACKAGE BODY.
8. DIMENSIONS D AND E TO BE DETERMINED AT DATUM PLANE C.

DIM	MILLIMETERS	
	MIN	MAX
A	0.95	1.25
A1	0.05	0.15
A2	0.90	1.20
b	0.17	0.27
D	9.00 BSC	
D1	7.00 BSC	
D2	4.90	5.10
E	9.00 BSC	
E1	7.00 BSC	
E2	4.90	5.10
e	0.50 BSC	
L	0.45	0.75
L2	0.25 BSC	
M	0°	7°

### RECOMMENDED SOLDERING FOOTPRINT\*

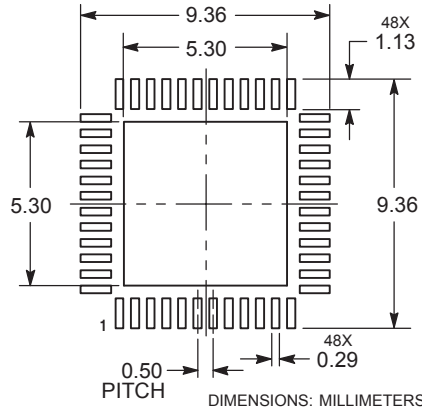

\*For additional information on our Pb-Free strategy and soldering details, please download the ON Semiconductor Soldering and Mounting Techniques Reference Manual, SOLDERRM/D.

ON Semiconductor and the ON logo are registered trademarks of Semiconductor Components Industries, LLC (SCILLC) or its subsidiaries in the United States and/or other countries. SCILLC owns the rights to a number of patents, trademarks, copyrights, trade secrets, and other intellectual property. A listing of SCILLC's product/patent coverage may be accessed at [www.onsemi.com/site/pdf/Patent-Marking.pdf](http://www.onsemi.com/site/pdf/Patent-Marking.pdf). SCILLC reserves the right to make changes without further notice to any products herein. SCILLC makes no warranty, representation or guarantee regarding the suitability of its products for any particular purpose, nor does SCILLC assume any liability arising out of the application or use of any product or circuit, and specifically disclaims any and all liability, including without limitation special, consequential or incidental damages. "Typical" parameters which may be provided in SCILLC data sheets and/or specifications can and do vary in different applications and actual performance may vary over time. All operating parameters, including "Typicals" must be validated for each customer application by customer's technical experts. SCILLC does not convey any license under its patent rights nor the rights of others. SCILLC products are not designed, intended, or authorized for use as components in systems intended for surgical implant into the body, or other applications intended to support or sustain life, or for any other application in which the failure of the SCILLC product could create a situation where personal injury or death may occur. Should Buyer purchase or use SCILLC products for any such unintended or unauthorized application, Buyer shall indemnify and hold SCILLC and its officers, employees, subsidiaries, affiliates, and distributors harmless against all claims, costs, damages, and expenses, and reasonable attorney fees arising out of, directly or indirectly, any claim of personal injury or death associated with such unintended or unauthorized use, even if such claim alleges that SCILLC was negligent regarding the design or manufacture of the part. SCILLC is an Equal Opportunity/Affirmative Action Employer. This literature is subject to all applicable copyright laws and is not for resale in any manner.