



Chipsmall Limited consists of a professional team with an average of over 10 year of expertise in the distribution of electronic components. Based in Hongkong, we have already established firm and mutual-benefit business relationships with customers from,Europe,America and south Asia,supplying obsolete and hard-to-find components to meet their specific needs.

With the principle of "Quality Parts,Customers Priority,Honest Operation,and Considerate Service",our business mainly focus on the distribution of electronic components. Line cards we deal with include Microchip,ALPS,ROHM,Xilinx,Pulse,ON,Everlight and Freescale. Main products comprise IC,Modules,Potentiometer,IC Socket,Relay,Connector.Our parts cover such applications as commercial,industrial, and automotives areas.

We are looking forward to setting up business relationship with you and hope to provide you with the best service and solution. Let us make a better world for our industry!



Contact us

Tel: +86-755-8981 8866 Fax: +86-755-8427 6832

Email & Skype: info@chipsmall.com Web: www.chipsmall.com

Address: A1208, Overseas Decoration Building, #122 Zhenhua RD., Futian, Shenzhen, China





ON Semiconductor®

<http://onsemi.com>

LV8827LFQA

Bi-CMOS IC For Brushless Motor Drive PWM Driver IC

Overview

The LV8827LFQA is a PWM-type driver IC designed for 3-phase brushless motors. The rotational speed can be controlled by inputting the PWM pulse from the outside, and changing Duty. The IC incorporates a latch-type constraint protection circuit.

Features

- I_O max = 1.5A (built-in output Tr)
- Speed control and synchronous rectification using direct PWM input (supports 3.3V inputs)
- 1-Hall FG output
- Latch type constraint protection circuit (the latch is released by S/S and F/R.)
- Forward/reverse switching circuit, Hall bias pin
- Power save circuit (Power save in stop mode)
- Current limiter circuit, Low-voltage protection circuit, Overheat protection circuit
- Charge pump circuit, 5V regulator output.
- Start/stop circuit (short brake when motor is to be stopped)

Specifications

Absolute Maximum Ratings at $T_a = 25^\circ\text{C}$

Parameter	Symbol	Conditions	Ratings	Unit
Supply voltage	V_{CC} max	V_{CC} pin	36	V
	V_G max	V_G pin	42	V
Output current	I_O max	$t \leq 500\text{ms}^*1$	1.5	A
Allowable power dissipation	P_d max2	Mounted on a circuit board.*2	1.35	W
Junction temperature	T_j max		150	$^\circ\text{C}$
Operating temperature	T_{opr}		-40 to +80	$^\circ\text{C}$
Storage temperature	T_{stg}		-55 to +150	$^\circ\text{C}$

*1 : T_j cannot exceed T_j max = 150°C

*2 : Specified circuit board : $40\text{mm} \times 50\text{mm} \times 0.8\text{mm}$, glass epoxy (four-layer board)

Caution 1) Absolute maximum ratings represent the value which cannot be exceeded for any length of time.

Caution 2) Even when the device is used within the range of absolute maximum ratings, as a result of continuous usage under high temperature, high current, high voltage, or drastic temperature change, the reliability of the IC may be degraded. Please contact us for the further details.

Stresses exceeding Maximum Ratings may damage the device. Maximum Ratings are stress ratings only. Functional operation above the Recommended Operating Conditions is not implied. Extended exposure to stresses above the Recommended Operating Conditions may affect device reliability.

LV8827LFQA

Allowable Operating range at $T_a = 25^\circ\text{C}$

Parameter	Symbol	Conditions	Ratings	Unit
Supply voltage range	V_{CC}		8.0 to 35	V
5V constant voltage output current	I_{REG}		0 to -10	mA
HB pin output current	I_{HB}		0 to -200	μA
FG pin applied voltage	V_{FG}		0 to 6	V
FG pin output current	I_{FG}		0 to 10	mA

Electrical Characteristics at $T_a = 25^\circ\text{C}$, $V_{CC} = 24\text{V}$

Parameter	Symbol	Conditions	Ratings			Unit
			min	typ	max	
Supply current 1	I_{CC1}			3.3	4.0	mA
Supply current 2	I_{CC2}	At stop		0.7	0.8	mA
Output block						
Low-side output ON resistance	$R_{ON}(L1)$	$I_O = 1.0\text{A}$		0.47	0.65	Ω
High-side output ON resistance	$R_{ON}(H1)$	$I_O = -1.0\text{A}$		0.67	0.9	Ω
Low-side output leak current	$I_L(L)$				50	μA
High-side output leak current	$I_L(H)$		-50			μA
Low-side diode forward voltage	$V_D(L1)$	$I_D = -1.0\text{A}$		1.0	1.2	V
High-side diode forward voltage	$V_D(H1)$	$I_D = 1.0\text{A}$		1.1	1.3	V
5V Constant-voltage Output						
Output voltage	V_{REG}	$I_O = -5\text{mA}$	4.8	5.1	5.4	V
Line regulation	$\Delta V(\text{REG1})$	$V_{CC} = 8.0$ to 35V , $I_O = -5\text{mA}$			50	mV
Load regulation	$\Delta V(\text{REG2})$	$I_O = -5\text{mA}$ to -10mA			100	mV
Hall Amplifier						
Input bias current	$I_B(\text{HA})$		-2			μA
Common-mode input voltage range 1	V_{ICM1}	When using Hall elements	0.3		$V_{REG}-1.7$	V
Common-mode input voltage range 2	V_{ICM2}	At one-side input bias (Hall IC application)	0		V_{REG}	V
Hall input sensitivity	V_{HIN}	SIN wave	80			mVp-p
Hysteresis width	$\Delta V_{IN}(\text{HA})$		9	20	35	mV
Input voltage Low \rightarrow High	V_{SLH}		3	9	16	mV
Input voltage High \rightarrow Low	V_{SHL}		-19	-11	-5	mV
CSD oscillator circuit						
High level output voltage	$V_{OH}(\text{CSD})$		2.7	3.0	3.3	V
Low level output voltage	$V_{OL}(\text{CSD})$		0.9	1.1	1.3	V
Amplitude	$V(\text{CSD})$		1.6	1.9	2.2	Vp-p
External capacitor charge current	$I_{CHG1}(\text{CSD})$	$V_{CHG1} = 2.0\text{V}$	-14	-11.5	-9	μA
External capacitor discharge current	$I_{CHG2}(\text{CSD})$	$V_{CHG2} = 2.0\text{V}$	9.5	12	14.5	μA
Oscillation frequency	$f(\text{CSD})$	$C = 0.022\mu\text{F}$ (Design target value)		130		Hz
Charge pump output (VG pin)						
Output voltage	V_{GOUT}			$V_{CC}+4.5$		V
CP1 pin						
Output ON resistance (High level)	$V_{OH}(\text{CP1})$	$I_{CP1} = -2\text{mA}$		500	700	Ω
Output ON resistance (Low level)	$V_{OL}(\text{CP1})$	$I_{CP1} = 2\text{mA}$		350	500	Ω
Charge pump frequency	$f(\text{CP})$		82	103	124	kHz
Internal PWM frequency						
Oscillation frequency	$f(\text{PWM})$		41	51.5	62	kHz
Current limiter operation						
Limiter voltage	V_{RF}		0.19	0.21	0.23	V

Continued on next page.

LV8827LFQA

Continued from preceding page.

Parameter	Symbol	Conditions	Ratings			Unit
			min	typ	max	
Thermal shutdown operation						
Thermal shutdown operation temperature	TSD	*Design target value (junction temperature)	150	165	180	°C
Hysteresis width	Δ TSD	*Design target value (junction temperature)		30		°C
HB pin						
Output voltage	VHB	IHB = -100 μ A	3.4	3.6	3.8	V
Low-voltage protection (5V constant-voltage output detection)						
Operation voltage	VSD		3.95	4.15	4.35	V
Hysteresis width	Δ VSD		0.2	0.3	0.4	V
FG pin (3FG pin)						
Output ON resistance	VOL (FG)	IFG = 5mA		40	60	Ω
Output leak current	IL (FG)	V _O = 5V			10	μ A
S/S pin						
High level input voltage	V _{IH} (SS)		2.0		VREG	V
Low level input voltage	V _{IL} (SS)		0		1.0	V
Input open voltage	V _{IO} (SS)		VREG-2.2	VREG-2.0	VREG-1.8	V
Hysteresis width	V _{IS} (SS)		0.25	0.33	0.4	V
High level input current	I _{IH} (SS)	V _{SS} = VREG	45	60	75	μ A
Low level input current	I _{IL} (SS)	V _{SS} = 0V	-115	-90	-65	μ A
PWMIN pin						
Recommended input frequency	f (PWIN)		0.5		60	kHz
High level input voltage	V _{IH} (PWIN)		2.0		VREG	V
Low level input voltage	V _{IL} (PWIN)		0		1.0	V
Input open voltage	V _{IO} (PWIN)		VREG-2.2	VREG-2.0	VREG-1.8	V
Hysteresis width	V _{IS} (PWIN)		0.25	0.33	0.4	V
High level input current	I _{IH} (PWIN)	VPWIN = VREG	45	60	75	μ A
Low level input current	I _{IL} (PWIN)	VPWIN = 0V	-115	-90	-65	μ A
F/R pin						
High level input voltage	V _{IH} (FR)	*Design target value	2.0		VREG	V
Low level input voltage	V _{IL} (FR)	*Design target value	0		1.0	V
Input open voltage	V _{IO} (FR)		VREG-2.2	VREG-2.0	VREG-1.8	V
Hysteresis width	V _{IS} (FR)	*Design target value	0.25	0.33	0.4	V
High level input current	I _{IH} (FR)	VF/R = VREG	45	60	75	μ A
Low level input current	I _{IL} (FR)	VF/R = 0V	-115	-90	-65	μ A

* : Design target value and no measurement is made.

LV8827LFQA

Package Dimensions

unit : mm (typ)

3430

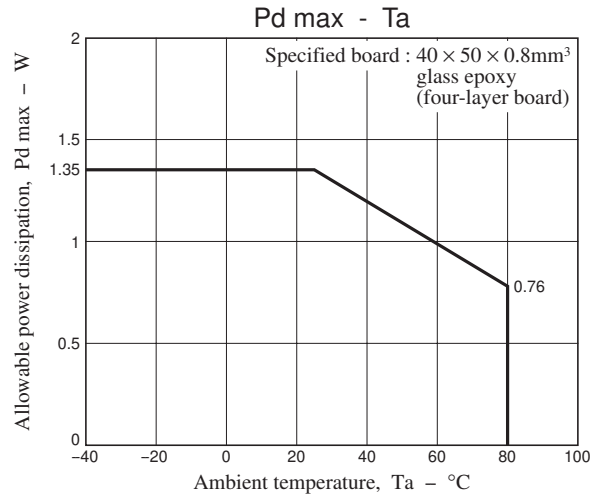
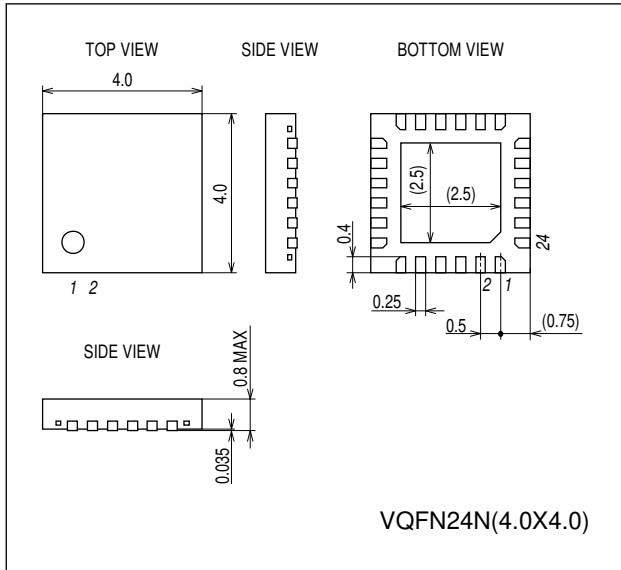

Pin Assignment

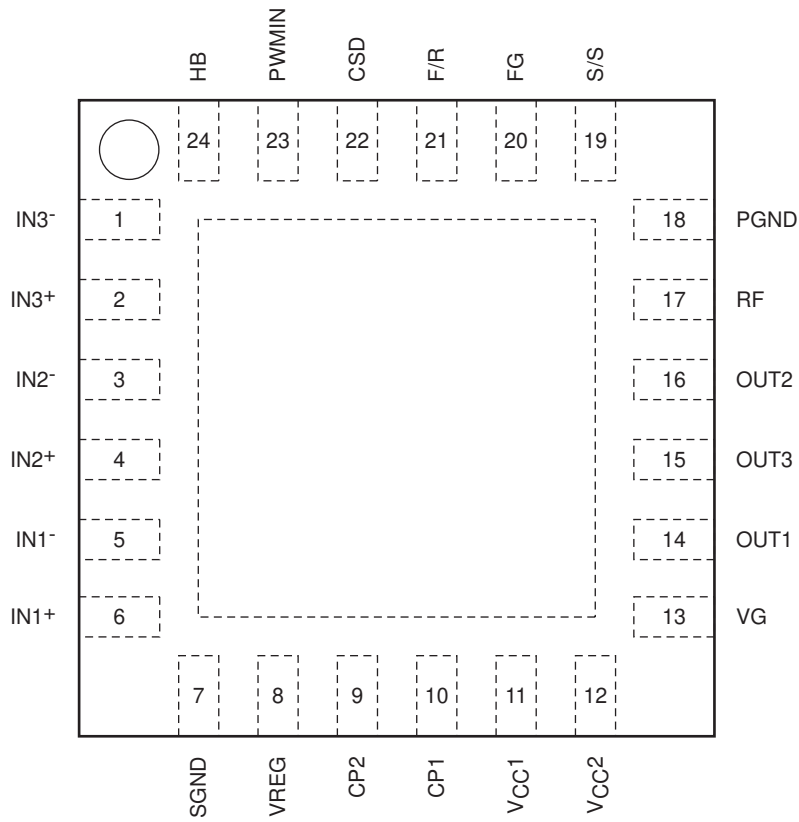

LV8827LFQA

Three-phase logic truth table (IN = "High" indicates the state where IN+ > IN-.)

("H" = SOURCE, "L" = SINK, and "M" = output OFF are shown with OUT1 to 3.)

F/R = [H]			F/R = [L]			Output		
IN1	IN2	IN3	IN1	IN2	IN3	OUT1	OUT2	OUT3
H	L	H	L	H	L	L	H	M
H	L	L	L	H	H	L	M	H
H	H	L	L	L	H	M	L	H
L	H	L	H	L	H	H	L	M
L	H	H	H	L	L	H	M	L
L	L	H	H	H	L	M	H	L

FG output			
IN1	IN2	IN3	FG
H	L	H	L
H	L	L	L
H	H	L	L
L	H	L	H
L	H	H	H
L	L	H	H

S/S pin, PWMIN pin

Input state	S/S pin	PWMIN pin
High or Open	Stop (short brake)	Output OFF
Low	Start	Output ON

CSD function

- When the S/S pin is in a STOP state → Protection released and count reset (Initial reset)
- When the F/R pin is switched → Protection released and count reset
- When 0% duty is detected at the PWMIN pin input → Protection released and count reset
- When low-voltage condition is detected → Protection released and count reset (Initial reset)
- When TSD condition is detected → Stop counting

LV8827LFQA

Internal Equivalent Circuit and Sample External Component Circuit

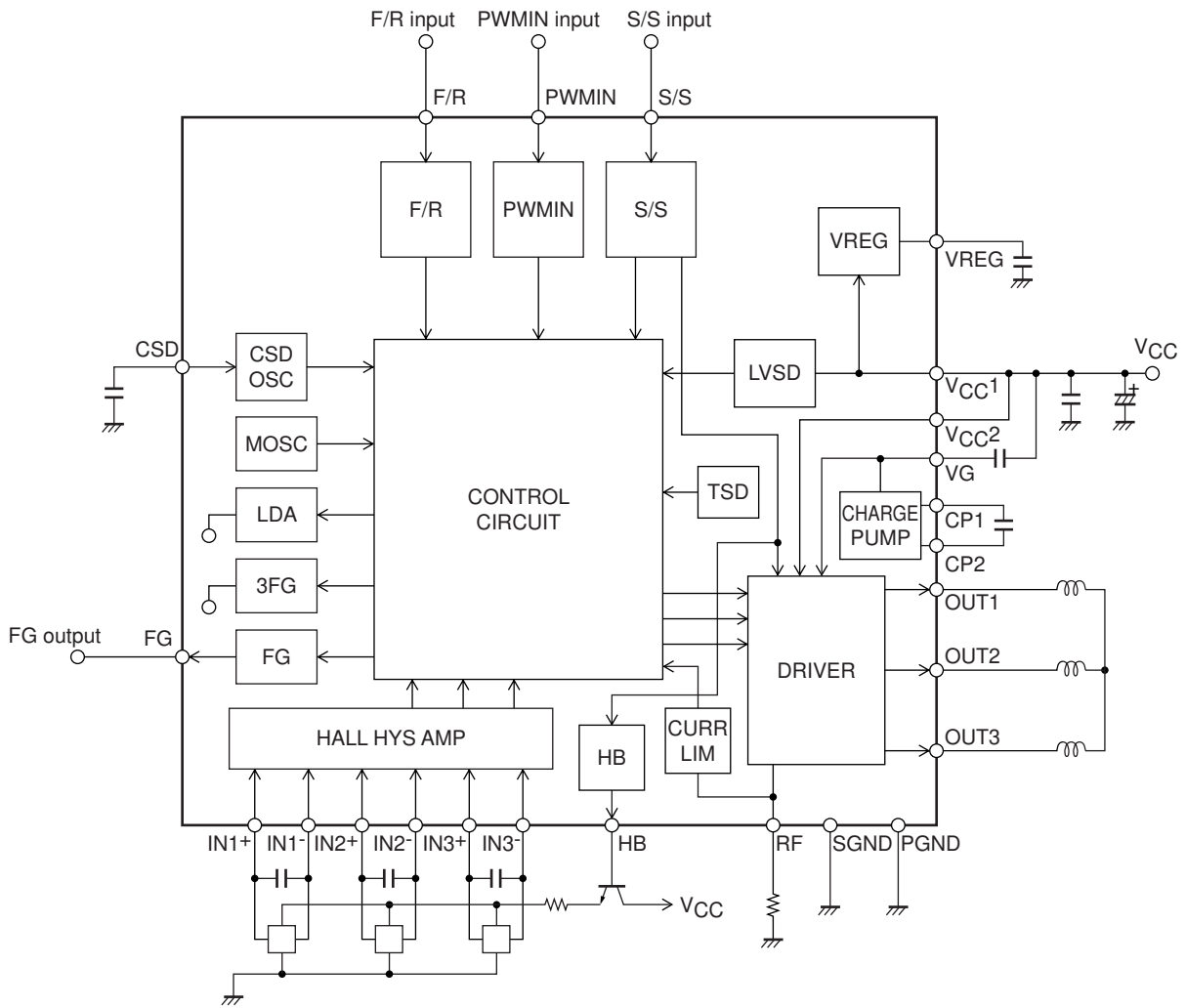

LV8827LFQA

Pin Functions

Pin No.	Pin Name	Pin function	Equivalent Circuit
1 2 3 4 5 6	IN3 ⁻ IN3 ⁺ IN2 ⁻ IN2 ⁺ IN1 ⁻ IN1 ⁺	Hall input pin. •High when IN ⁺ > IN ⁻ . Low in reverse relationship. The input amplitude of over 100mVp-p (differential) is desirable in the Hall inputs. Insert a capacitor between the IN ⁺ and IN ⁻ pins if the noise on the Hall signal is a problem.	
7	SGND	Control circuit block ground pin.	
8	VREG	5V regulator output pin (control circuit power supply). Insert a capacitor between this pin and ground for stabilization. About 0.1μF is necessary. (Refer to 11 pages "5 is Low-voltage Protection Circuit.", 12 pages "10 is VREG Stabilization.")	
9 10	CP2 CP1	Charge pump capacitor connection pin. Insert capacitor between CP1 and CP2.	
11 12	V _{CC} 1 V _{CC} 2	For Control (Pin 11) and for output (Pin 12) power pin. Insert a capacitor between this pin and ground to prevent the influence of noise, etc. (Refer to 12 pages "9 is Power Supply Stabilization.")	
13	VG	Charge pump output pin. (Upper-side FET gate power supply) Insert a capacitor between this pin and V _{CC} . (Refer to 12 pages "11 is Charge pump Circuit.")	

Continued on next page.

LV8827LFQA

Continued from preceding page.

Pin No.	Pin Name	Pin function	Equivalent Circuit
14 15 16	OUT1 OUT3 OUT2	Output pin. PWM is controlled by the upper-side FET.	
17	RF	Output current detection pin. Insert a low resistance resistor (R_f) between this pin and ground. (Refer to 10 pages "2 is Current Limiter Circuit.")	
18	PGND	Out circuit block ground pin.	
19	S/S	Pin to select the start/stop type. Stop = High or open Start = Low (Refer to 12 pages "8 is Power Saving Circuit.")	
20	FG	1-Hall FG signal output pin. Open drain output.	

Continued on next page.

LV8827LFQA

Continued from preceding page.

Pin No.	Pin Name	Pin function	Equivalent Circuit
21	F/R	Pin to select the forward/reverse type. This pin goes to the high level when open.	
22	CSD	Pin to set the constraint protection circuit operating time and initial reset pulse. Insert a capacitor between this pin and ground. Insert a resistor in parallel with the capacitor if the protection circuit is not to be used. (Refer to 10 pages "4 is Constraint Protection Circuit.")	
23	PWMIN	External PWM input pin. Apply an external PWM input signal to this pin. (Input frequency range is from 0.5 to 60kHz.) PWM ON = Low PWM OFF = High or open (Refer to 10 pages "3 is Speed control method.")	
24	HB	HALL bias pin (3.6V output). Connect an NPN transistor. (Refer to 11 pages "7 Hall Input Signal.")	

Description of LV8827LFQA

1. Output Drive Circuit

This IC adopts a direct PWM drive method to reduce power loss in the output. It regulates the drive force of the motor by changing the output on duty. The output PWM switching is performed by the upper-side output transistor. The current regeneration route during the normal PWMOFF passes through the parasitic diode of the output DMOS. This IC performs synchronous rectification, and is intended to reduce heat generation compared to diode regeneration.

2. Current Limiter Circuit

The current limiter circuit limits the output current peak value to a level determined by the equation $I = V_{RF}/R_f$ ($V_{RF} = 0.21V$ (typical), R_f : current detection resistor). This circuit suppresses the output current by reducing the output on duty.

The current limiter circuit has an operation delay (approx. 700ns) to detect reverse recovery current flowing in the diode due to the PWM operation, and prevent a malfunction of the current limiting operation. If the coil resistance of the motor is small, or the inductance is low, the current at startup (the state in which there is no back electromotive force generated in the motor) will change rapidly. As a result, the operation delay may sometimes cause the current limiting operation to take place at a value above the set current. In such a case, it is necessary to set the current limit value while taking into consideration the increase in current due to the delay.

* Regarding the PWM frequency in the current limiter circuit

The PWM frequency in the current limiter circuit is determined by the internal reference oscillator, and is approximately 50kHz.

3. Speed control method

Pulses are input to the PWMIN pin, and the output can be controlled by varying the duty cycle of these pulses.

When a low-level input voltage is applied to the PWMIN pin, the output at the PWM side (upper side) is set to ON.

When a high-level input voltage is applied to the PWMIN pin, the output at the PWM side (upper side) is set to OFF.

If it is necessary to input pulses using inverted logic, this can be done by adding an external transistor (NPN).

It is judged Duty=0%, count reset and the HB pin output of the CSD circuit become "L" when the input of the PWMIN pin becomes "H" level during the fixed time, and it enters the state of a short brake.

4. Constraint Protection Circuit

The LV8827LFQA includes a constraint protection circuit for protecting the IC and the motor in a motor constraint mode.

This circuit operates when the motor is in an operation condition and the Hall signal does not switch over for a certain period. Note that while this constraint protection is operating, the upper-side output transistor will be OFF.

Time setting is performed according to the capacitance of the capacitor connected to the CSD pin.

$$\text{Set time (s)} \approx 90 \times C (\mu\text{F})$$

When a 0.022 μF capacitor is connected, the protection time becomes approximately 2.0 seconds. The set time must be selected to a value that provides adequate margin with respect to the motor startup time.

Conditions for releasing the constraint protection state:

- When the S/S pin is in a STOP state → Protection released and count reset (Initial reset)
- When the F/R pin is switched → Protection released and count reset
- When 0% duty is detected at the PWMIN pin input → Protection released and count reset
- When low-voltage condition is detected → Protection released and count reset (Initial reset)
- (• When TSD condition is detected → Stop counting)

The CSD pin also functions as the initial reset pulse generation pin. If it is connected to ground, the logic circuit will go into a reset state, preventing speed control from taking place. Consequently, when not using constraint protection, connect a resistor of approximately 220k Ω and a capacitor of about 4700pF in parallel to ground.

5. Low-voltage Protection Circuit

The LV8827LFQA incorporates a comparator that uses the band gap voltage as the reference. The circuit monitors the voltage at the VREG pin (5V) while the S/S pin is low and activates the protection circuit when the voltage at the VREG pin falls below 4.15V (typ.).

When this happens, the state of the output transistors for all phases, and the short brake (bottom side is short) mode is established.

Source side: All OFF. Synchronous rectification is not performed.

Sink side: All ON.

Furthermore, when the VREG voltage falls even further and the internal circuit can no longer operate properly, all the

output transistors are set to OFF.

In order to ensure that the IC does not exhibit any unstable behavior when the VREG voltage has increased or decreased around 4.15V, a hysteresis of 0.3V (typ.) is provided. As a result, when the VREG voltage recovers to 4.45V (typ.) after the low-voltage protection circuit has been activated, all output transistors return to their operating state.

6. Thermal shutdown Circuit

When the IC junction temperature exceeds 165°C (design target value), the thermal shutdown circuit is activated, and all the output transistors are set to OFF.

When the IC junction temperature goes below the hysteresis temperature of 30°C (design target value) or more, all the output transistors return to their operating state.

However, as the thermal shutdown circuit is activated only when the junction temperature of the IC has exceeded the rating, its activation does not constitute a guarantee that the product that incorporates this circuit will be protected from damage or destruction.

7. Hall Input Signal

A pulse input with the amplitude in excess of the hysteresis (35mV maximum) is required for the Hall inputs.

It is desirable that the amplitude of the Hall input signal be 100mVp-p or more in consideration of the effect of noise and phase displacement.

If disturbances to the output waveform (during phase switching) occur due to noise, connect a capacitor between the Hall input pins to prevent such disturbances. In the constraint protection circuit, the Hall input is utilized as a judgment signal. Although the circuit ignores a certain amount of noise, caution is necessary.

If all three phases of the Hall input signal go to the same input state (HHH or LLL), the outputs are all set to the OFF state.

If the Hall IC is used, fixing one side of the inputs (either the + or – side) at a voltage within the common-mode input voltage range (between 0.3V and VREG-1.7V) allows the other input side to be used as an input over the 0V to VREG range.

○ Method of connecting Hall elements

Type (1) connection (three Hall elements connected in series)

Advantages

- Because the current flowing in Hall elements can be shared by connecting the Hall elements in series, the current consumption is less than that of a parallel-connected arrangement.
- The use of a current limiting resistor can be eliminated.
- Fluctuations of amplitude with temperature are reduced.

Disadvantages

- Because only 1V can be applied to one Hall device, there is a possibility that adequate amplitude cannot be obtained.
- The current flowing in the Hall elements varies with temperature.
- HALL element unevenness (input resistance in particular) is easy to influence the amplitude.

Type (2) connection (three Hall elements connected in parallel)

Advantages

- The current flowing in the Hall elements can be determined by the current limiting resistor.
- The voltage applied to the Hall elements can be varied, enabling adequate amplitude to be obtained.

Disadvantages

- Because it is necessary to supply current separately to each Hall element, the current consumption becomes large.
- A current limiting resistor is necessary.
- The amplitude varies with temperature.

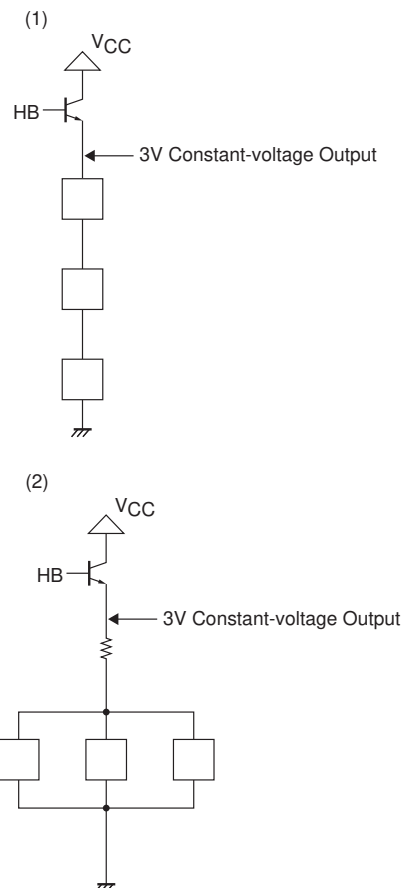

LV8827LFQA

○ HB pin

The HB pin is used for cutting off the current flowing in the Hall elements during standby (for saving electricity). The output from the HB pin is set to OFF in the following cases.

- When the S/S pin is in a STOP state
- When 0% duty is detected at the PWMIN pin input

8. Power Saving Circuit (Start/Stop circuit)

To save power when the LV8827LFQA is in the stop state, most of the circuit is stopped, aiming at reducing current consumption. If the Hall bias pin is used, the current consumption in the power-saving mode will be approximately 700μA. Even in the power-saving mode, a 5V regulator voltage is output. Also, in the power-saving mode, the IC is in a short break state. (lower-side shorted)

9. Power Supply Stabilization

This IC generates a large output current, and employs a switching drive method, so the power supply line level can be disturbed easily. For this reason, it is necessary to connect a capacitor (electrolytic) of sufficient capacitance between the VCC pin and ground to ensure a stable voltage. Connect the ground side of the capacitor to the PGND pin, which is the power ground, as close as possible to the pin. If it is not possible to connect a capacitor of sufficiently large capacitance close to the pin, connect a ceramic capacitor of approximately 0.1μF to the vicinity of the pin. If diodes are inserted in the power supply line to prevent IC destruction resulting from reverse-connecting the power supply, the power supply lines are even more easily disrupted. And even larger capacitor is required.

10. VREG Stabilization

To stabilize the VREG voltage, which is the power supply for the control circuit, connect a capacitor of 0.1μF or larger. Connect the ground of this capacitor as close as possible to the control block ground (SGND pin) of the IC.

11. Charge pump Circuit

The voltage is stepped-up by the charge pump circuit, causing the gate voltage of the upper-side output FET to be generated. The voltage is stepped-up by capacitor CP connected between pins CP1 and CP2, causing charge to accumulate in capacitor CG connected between pins VG and VCC. The capacitance of CP and CG must always satisfy the following relationship.

$$CG \geq 4 \times CP$$

Charging and discharging of capacitor CP take place based on a frequency of 100kHz. When the capacitance of capacitor CP is large, the current supply capability of power supply VG will increase. However, if the capacitance is too large, the charging and discharging operations will be insufficient. The larger the capacitance of capacitor CG, the more stable voltage VG will become. However, if the capacitance is made too large, the period during which voltage VG is generated when the power is switched ON will become long, so caution is necessary.

The capacitance settings of CP and CG should be the following.

$$CP = 0.01\mu F$$

$$CG = 0.1\mu F$$

12. Difference point of LV8827LFQA and LV8829LFQA

This difference that IC is the more following compared with LV8829LFQA exists.

	LV8827LFQA	LV8829LFQA
When Duty=0% of PWM input is detected	Short brake	Synchronous rectification OFF (Free run)
At the low frequency number of PWM input (About 7.5kHz under)	Like synchronous rectification ON	Synchronous rectification OFF
At low ON Duty of the PWM input (ex. frequency: 20kHz, ON Duty: 3% under)	Like synchronous rectification ON	Synchronous rectification OFF
Backflow current detecting function	non	It is. (At detection -> Synchronous rectification OFF)

13. Metal part at the rear of the IC

The metal part at the rear of the IC (exposed die-pad) constitutes the sub ground of the IC, so connect it to the control ground (SGND pin) and power ground pin (PGND) at points close to the IC.

LV8827LFQA

14. Notes on Using the IC

This IC performs synchronous rectification in order to achieve high-efficiency drive.

The synchronous rectification operation reduces the output transistor loss so it has the effect of reducing heat generation and improving efficiency.

However, the synchronous rectification operation may cause the supply voltage to rise depending on the conditions under which the IC is used, such as:

- When the output duty ratio has suddenly decreased
- When the PWM input frequency is low, etc.

Protective measures must be taken to ensure that the maximum ratings are not exceeded even when the supply voltage has risen. These measures include:

- Appropriate selection of the capacitance of the capacitor inserted between the power supply and the ground
- Insertion of a zener diode between the power supply and the ground

ON Semiconductor and the ON logo are registered trademarks of Semiconductor Components Industries, LLC (SCILLC). SCILLC owns the rights to a number of patents, trademarks, copyrights, trade secrets, and other intellectual property. A listing of SCILLC's product/patent coverage may be accessed at www.onsemi.com/site/pdf/Patent-Marking.pdf. SCILLC reserves the right to make changes without further notice to any products herein. SCILLC makes no warranty, representation or guarantee regarding the suitability of its products for any particular purpose, nor does SCILLC assume any liability arising out of the application or use of any product or circuit, and specifically disclaims any and all liability, including without limitation special, consequential or incidental damages. "Typical" parameters which may be provided in SCILLC data sheets and/or specifications can and do vary in different applications and actual performance may vary over time. All operating parameters, including "Typicals" must be validated for each customer application by customer's technical experts. SCILLC does not convey any license under its patent rights nor the rights of others. SCILLC products are not designed, intended, or authorized for use as components in systems intended for surgical implant into the body, or other applications intended to support or sustain life, or for any other application in which the failure of the SCILLC product could create a situation where personal injury or death may occur. Should Buyer purchase or use SCILLC products for any such unintended or unauthorized application, Buyer shall indemnify and hold SCILLC and its officers, employees, subsidiaries, affiliates, and distributors harmless against all claims, costs, damages, and expenses, and reasonable attorney fees arising out of, directly or indirectly, any claim of personal injury or death associated with such unintended or unauthorized use, even if such claim alleges that SCILLC was negligent regarding the design or manufacture of the part. SCILLC is an Equal Opportunity/Affirmative Action Employer. This literature is subject to all applicable copyright laws and is not for resale in any manner.