



Chipsmall Limited consists of a professional team with an average of over 10 year of expertise in the distribution of electronic components. Based in Hongkong, we have already established firm and mutual-benefit business relationships with customers from,Europe,America and south Asia,supplying obsolete and hard-to-find components to meet their specific needs.

With the principle of “Quality Parts,Customers Priority,Honest Operation,and Considerate Service”,our business mainly focus on the distribution of electronic components. Line cards we deal with include Microchip,ALPS,ROHM,Xilinx,Pulse,ON,Everlight and Freescale. Main products comprise IC,Modules,Potentiometer,IC Socket,Relay,Connector.Our parts cover such applications as commercial,industrial, and automotives areas.

We are looking forward to setting up business relationship with you and hope to provide you with the best service and solution. Let us make a better world for our industry!



Contact us

Tel: +86-755-8981 8866 Fax: +86-755-8427 6832

Email & Skype: info@chipsmall.com Web: www.chipsmall.com

Address: A1208, Overseas Decoration Building, #122 Zhenhua RD., Futian, Shenzhen, China



Hyper TOPLED® White LED

LW T676

Non-RoHS compliant version of product will be discontinued acc. to OS-PD-2005-005.

The product itself will remain within RoHS compliant version.



Besondere Merkmale

- **Gehäusertyp:** weißes P-LCC-2 Gehäuse, farbiger diffuser Verguss
- **Besonderheit des Bauteils:** extrem breite Abstrahlcharakteristik; ideal für Hinterleuchtungen und Einkopplungen in Lichtleiter
- **Farbort:** x = 0,30, y = 0,32 nach CIE 1931 (weiß)
- **typische Farbtemperatur:** 7300 K
- **Farbwiedergabeindex:** 80
- **Abstrahlwinkel:** extrem breite Abstrahlcharakteristik (120°)
- **Technologie:** GaN
- **optischer Wirkungsgrad:** 2 lm/W
- **Gruppierungsparameter:** Lichtstärke, Farbort
- **Verarbeitungsmethode:** für alle SMT-Bestücktechniken geeignet
- **Lötmethod:** IR Reflow Löten und Wellenlöten (TTW)
- **Vorbehandlung:** nach JEDEC Level 2
- **Gurtung:** 8-mm Gurt mit 2000/Rolle, ø180 mm oder 8000/Rolle, ø330 mm
- **ESD-Festigkeit:** ESD-sicher bis 2 kV nach JESD22-A114-B

Anwendungen

- Informationsanzeigen im Innenbereich
- Hinterleuchtung (LCD, Schalter, Tasten, Displays, Werbebeleuchtung, Allgemeinbeleuchtung)
- Innenbeleuchtung im Automobilbereich (z.B. Instrumentenbeleuchtung, u.ä.)
- Signal- und Symbolleuchten
- Markierungsbeleuchtung (z.B. Stufen, Fluchtwege, u.ä.)
- Allgemeinbeleuchtung

Features

- **package:** white P-LCC-2 package, colored diffused resin
- **feature of the device:** extremely wide viewing angle; ideal for backlighting and coupling in light guides
- **color coordinates:** x = 0.30, y = 0.32 acc. to CIE 1931 (white)
- **typ. color temperature:** 7300 K
- **color reproduction index:** 80
- **viewing angle:** extremely wide (120°)
- **technology:** GaN
- **optical efficiency:** 2 lm/W
- **grouping parameter:** luminous intensity, color coordinates
- **assembly methods:** suitable for all SMT assembly methods
- **soldering methods:** IR reflow soldering and TTW soldering
- **preconditioning:** acc. to JEDEC Level 2
- **taping:** 8 mm tape with 2000/reel, ø180 mm or 8000/reel, ø330 mm
- **ESD-withstand voltage:** up to 2 kV acc. to JESD22-A114-B

Applications

- indoor displays
- backlighting (LCD, switches, keys, displays, illuminated advertising, general lighting)
- interior automotive lighting. (e.g. dashboard backlighting, etc.)
- signal and symbol luminaire
- marker lights (e.g. steps, exit ways, etc.)
- general lighting

Bestellinformation
Ordering Information

Typ	Emissions- farbe	Lichtstärke ¹⁾ Seite 15	Lichtstrom ²⁾ Seite 15	Bestellnummer
Type	Color of Emission	Luminous Intensity ¹⁾ page 15	Luminous Flux ²⁾ page 15	Ordering Code
		$I_F = 10 \text{ mA}$ $I_V \text{ (mcd)}$	$I_F = 10 \text{ mA}$ $\Phi_V \text{ (lm)}$	
LW T676-M1N1-25	white	18.0 ... 35.5	77 (typ.)	Q62703Q5107
LW T676-N1P2-25		28.0 ... 71.0	140 (typ.)	Q62703Q6239

Anm.: -25 Farbselektiert nach Farbortgruppen, Lieferung in Einzelgruppen (siehe Seite 5)

Note: -25 Color selection acc. to chromaticity coordinate groups, delivery in single groups (see page 5)

Grenzwerte
Maximum Ratings

Bezeichnung Parameter	Symbol Symbol	Wert Value	Einheit Unit
Betriebstemperatur Operating temperature range	T_{op}	- 40 ... + 100	°C
Lagertemperatur Storage temperature range	T_{stg}	- 40 ... + 100	°C
Sperrschichttemperatur Junction temperature	T_j	+ 100	°C
Durchlassstrom Forward current ($T_A=25^\circ\text{C}$)	I_F	20	mA
Stoßstrom Surge current $t \leq 10 \mu\text{s}$, $D = 0.005$, $T_A=25^\circ\text{C}$	I_{FM}	0.2	A
Sperrspannung ^{3) Seite 15} Reverse voltage ^{3) page 15} ($T_A=25^\circ\text{C}$)	V_R	12	V
Leistungsaufnahme Power consumption ($T_A=25^\circ\text{C}$)	P_{tot}	85	mW
Wärmewiderstand Thermal resistance Sperrschicht/Umgebung ^{4) Seite 15} Junction/ambient ^{4) page 15}	$R_{th JA}$	500	K/W
Sperrschicht/Lötpad Junction/solder point	$R_{th JS}$	280	K/W

Kennwerte
Characteristics
 $(T_A = 25\text{ °C})$

	Symbol Symbol	Wert Value	Einheit Unit
Farbkoordinate x nach CIE 1931 ⁵⁾ Seite 15 (typ.) Chromaticity coordinate x acc. to CIE 1931 ⁵⁾ page 15 $I_F = 10\text{ mA}$	x	0.30*	–
Farbkoordinate y nach CIE 1931 ⁵⁾ Seite 15 (typ.) Chromaticity coordinate y acc. to CIE 1931 ⁵⁾ page 15 $I_F = 10\text{ mA}$	y	0.32*	–
Abstrahlwinkel bei 50 % I_V (Vollwinkel) (typ.) Viewing angle at 50 % I_V	2φ	120	Grad deg.
Durchlassspannung ⁶⁾ Seite 15 (typ.) Forward voltage ⁶⁾ page 15 (max.) $I_F = 10\text{ mA}$	V_F V_F	3.5 4.1	V V
Sperrstrom (typ.) Reverse current (max.) $V_R = 12\text{ V}$	I_R I_R	0.01 10	μA μA
Temperaturkoeffizient von x (typ.) Temperature coefficient of x $I_F = 10\text{ mA}; -10\text{ °C} \leq T \leq 100\text{ °C}$	TC_x	0.07	$10^{-3}/\text{K}$
Temperaturkoeffizient von y (typ.) Temperature coefficient of y $I_F = 10\text{ mA}; -10\text{ °C} \leq T \leq 100\text{ °C}$	TC_y	0.25	$10^{-3}/\text{K}$
Temperaturkoeffizient von V_F (typ.) Temperature coefficient of V_F $I_F = 10\text{ mA}; -10\text{ °C} \leq T \leq 100\text{ °C}$	TC_V	– 3.1	mV/K
Optischer Wirkungsgrad (typ.) Optical efficiency $I_F = 10\text{ mA}$	η_{opt}	2	lm/W

* Einzelgruppen siehe Seite 5
Individual groups on page 5

Farbortgruppen^{5) Seite 15}
Chromaticity Coordinate Groups^{5) page 15}

	x		y	
	min.	max.	min.	max.
2	0.280	0.305	0.295	0.325
3	0.290	0.315	0.310	0.340
4	0.295	0.320	0.340	0.370
5	0.305	0.330	0.355	0.385

Helligkeits-Gruppierungsschema
Brightness Groups

Helligkeitshalbgruppe Brightness Half Group	Lichtstärke ^{1) Seite 15} Luminous Intensity ^{1) page 15} I_V (mcd)	Lichtstrom ^{2) Seite 15} Luminous Flux ^{2) page 15} Φ_V (lm)
M1	18.0 ... 22.4	60 (typ.)
M2	22.4 ... 28.0	75 (typ.)
N1	28.0 ... 35.5	95 (typ.)
N2	35.5 ... 45.0	120 (typ.)
P1	45.0 ... 56.0	150 (typ.)
P2	56.0 ... 71.0	190 (typ.)

Anm.: Die Standardlieferform von Serientypen beinhaltet eine untere bzw. eine obere Familiengruppe. Diese besteht aus 3 bzw. 4 Helligkeitshalbgruppen. Einzelne Helligkeitshalbgruppen sind nicht bestellbar.

Note: The standard shipping format for serial types includes a lower or upper family group of 3 or 4 individual brightness half groups. Individual brightness half groups cannot be ordered.

Gruppenbezeichnung auf Etikett
Group Name on Label

Beispiel: N2-4

Example: N2-4

Helligkeitshalbgruppe Brightness Half Group	Farbortgruppe Chromaticity coordinate group
N2	4

Anm.: In einer Verpackungseinheit / Gurt ist immer nur eine Gruppe für jede Selektion enthalten.

Note: No packing unit / tape ever contains more than group for each selection.

Relative spektrale Emission²⁾ Seite 15**Relative Spectral Emission²⁾** page 15

$V(\lambda)$ = spektrale Augenempfindlichkeit / Standard eye response curve

$I_{rel} = f(\lambda)$; $T_A = 25\text{ °C}$; $I_F = 10\text{ mA}$

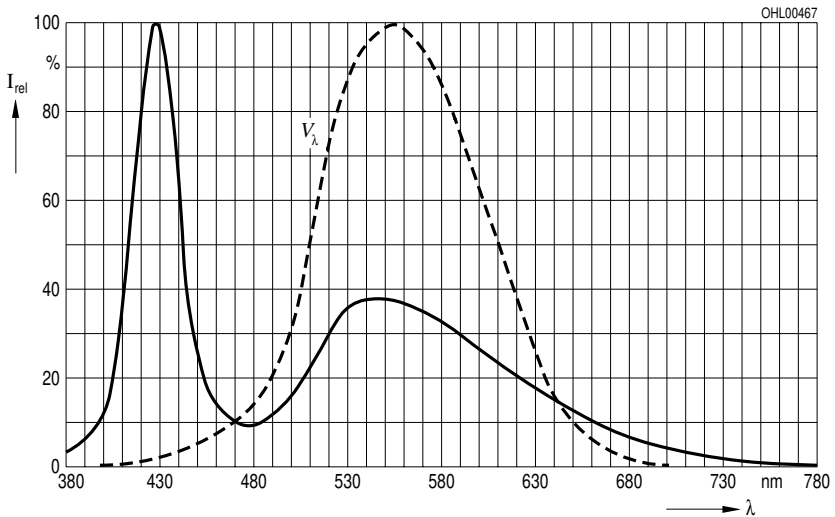
**Abstrahlcharakteristik²⁾** Seite 15**Radiation Characteristic²⁾** page 15

$I_{rel} = f(\varphi)$; $T_A = 25\text{ °C}$

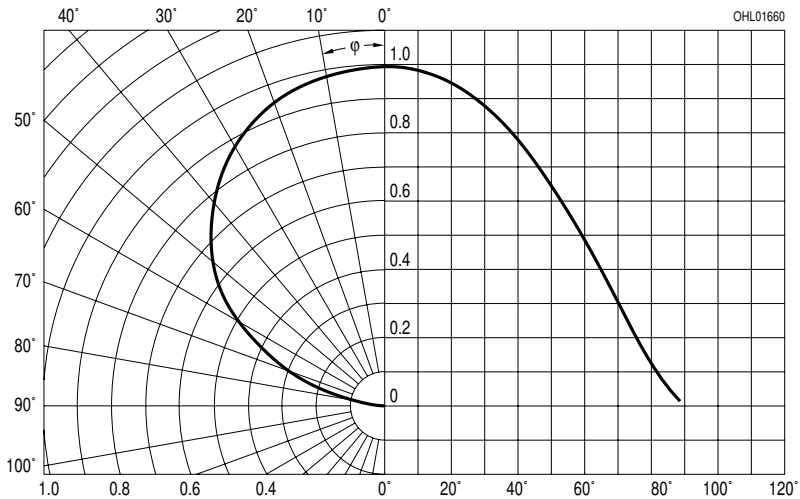

Durchlassstrom^{2) 7) Seite 15}Forward Current^{2) 7) page 15}

$$I_F = f(V_F); T_A = 25\text{ °C}$$

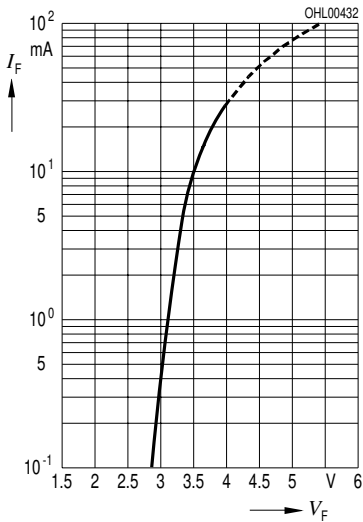
Relative Lichtstärke^{2) 7) Seite 15}Relative Luminous Intensity^{2) 7) page 15}

$$I_V/I_{V(10\text{ mA})} = f(I_F); T_A = 25\text{ °C}$$

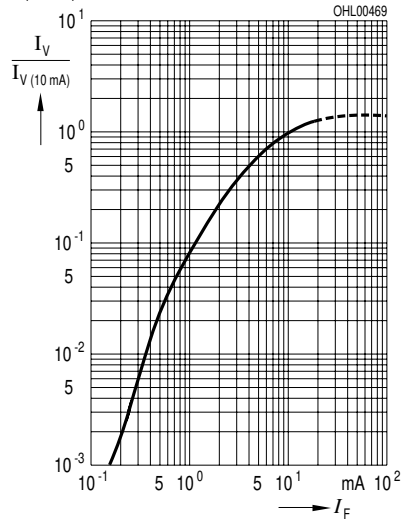
Relative Lichtstärke^{2) Seite 15}Relative Luminous Intensity^{2) page 15}

$$I_V/I_{V(25\text{ °C})} = f(T_J); I_F = 10\text{ mA}$$

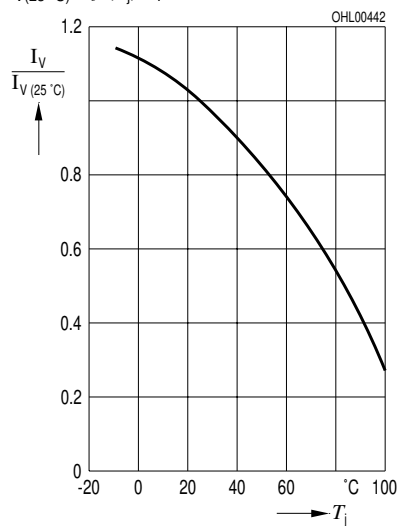

Maximal zulässiger Durchlassstrom
Max. Permissible Forward Current

$I_F = f(T)$

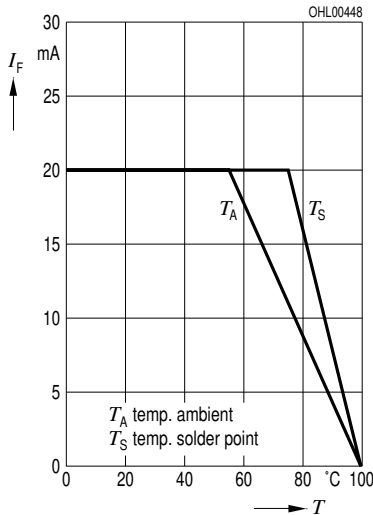

Zulässige Impulsbelastbarkeit $I_F = f(t_p)$
Permissible Pulse Handling Capability
 Duty cycle $D =$ parameter, $T_A = 25\text{ °C}$

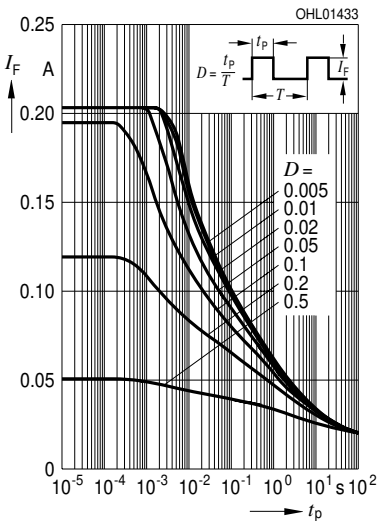

Zulässige Impulsbelastbarkeit $I_F = f(t_p)$
Permissible Pulse Handling Capability
 Duty cycle $D =$ parameter, $T_A = 85\text{ °C}$

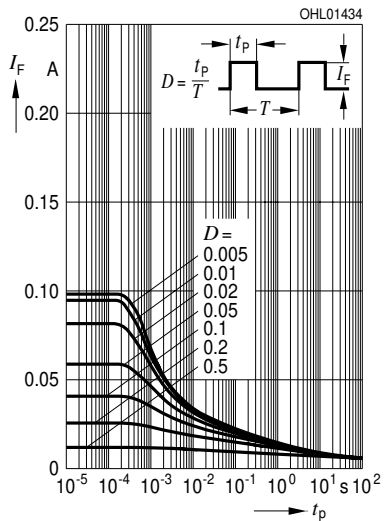

Empfohlenes Lötpaddesign^{8) 9)} Seite 15
Recommended Solder Pad^{8) 9)} page 15

IR Reflow Löten
IR Reflow Soldering

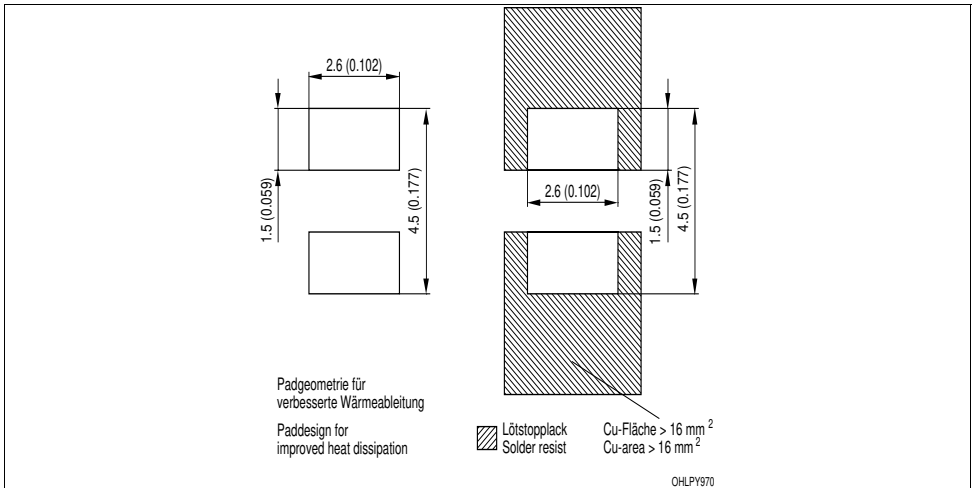

Empfohlenes Lötpaddesign verwendbar für TOPLED® und Power TOPLED®

IR Reflow Löten⁸⁾ Seite 15

Recommended Solder Pad useable for TOPLED® and Power TOPLED®

IR Reflow Soldering⁸⁾ page 15

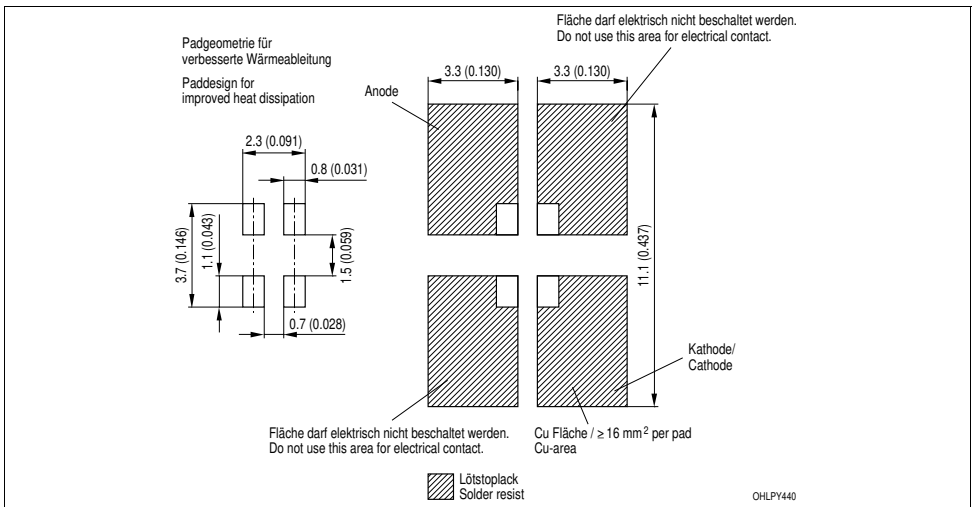

Lötbedingungen
Soldering Conditions
IR-Reflow Lötprofil
IR Reflow Soldering Profile

Vorbehandlung nach JEDEC Level 2
 Preconditioning acc. to JEDEC Level 2
 (nach IPC 9501)
 (acc. to IPC 9501)

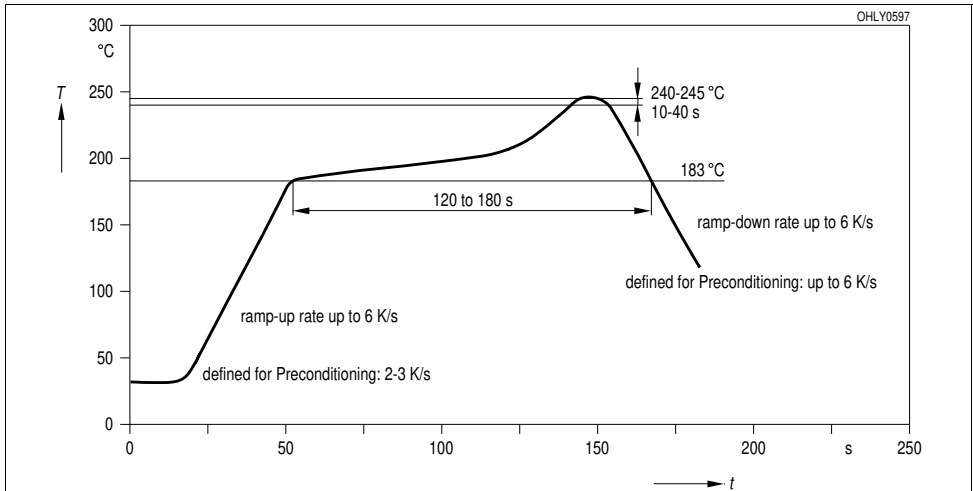

Wellenlöten (TTW)
TTW Soldering

(nach CECC 00802)
 (acc. to CECC 00802)

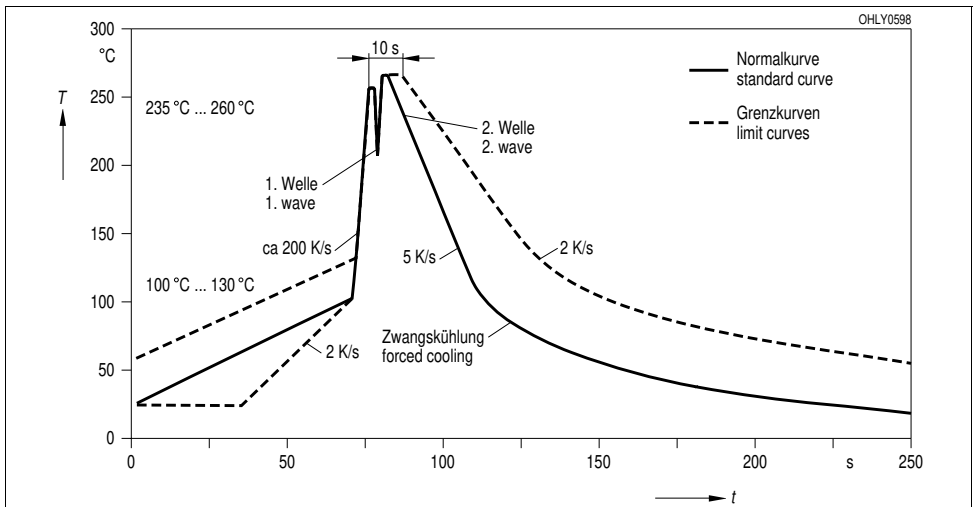

Barcode-Produkt-Etikett (BPL) Barcode-Product-Label (BPL)

OSRAM Opto Semiconductors

Lx xxxx Bin1: Bin Information Color 1
Product Name Bin2:
Bin3:

(6P) BATCH NO: Batch Number
Bar Code

(1T) LOT NO: Lot Number (9D) D/C: Date Code
Bar Code

(X) PROD NO: Product Code (Q) QTY: Product Quantity per Reel (G) GROUP: X - X - X
Bar Code

ML Temp ST
2 245 C R
2 260 C T

Additional TEXT
R077 DEMY
PACKVAR: Packing Type

Forward Voltage Rank
Wavelength Rank
Brightness Rank

OHA02043

Gurtverpackung Tape and Reel

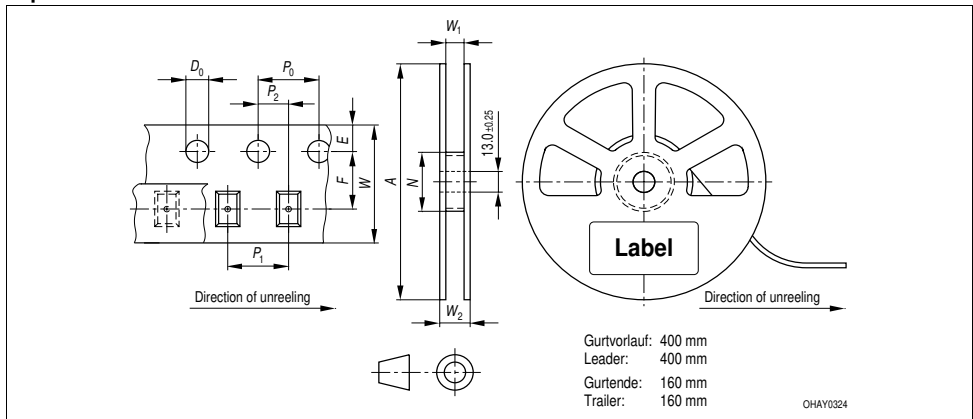

Tape dimensions in mm (inch)

W	P_0	P_1	P_2	D_0	E	F
$8 + 0.3$ $- 0.1$	4 ± 0.1 (0.157 ± 0.004)	4 ± 0.1 (0.157 ± 0.004)	2 ± 0.05 (0.079 ± 0.002)	$1.5 + 0.1$ (0.059 + 0.004)	1.75 ± 0.1 (0.069 ± 0.004)	3.5 ± 0.05 (0.138 ± 0.002)

Reel dimensions in mm (inch)

A	W	N_{\min}	W_1	$W_{2 \max}$
180 (7)	8 (0.315)	60 (2.362)	$8.4 + 2 (0.331 + 0.079)$	14.4 (0.567)
330 (13)	8 (0.315)	60 (2.362)	$8.4 + 2 (0.331 + 0.079)$	14.4 (0.567)

Trockenverpackung und Materialien

Dry Packing Process and Materials

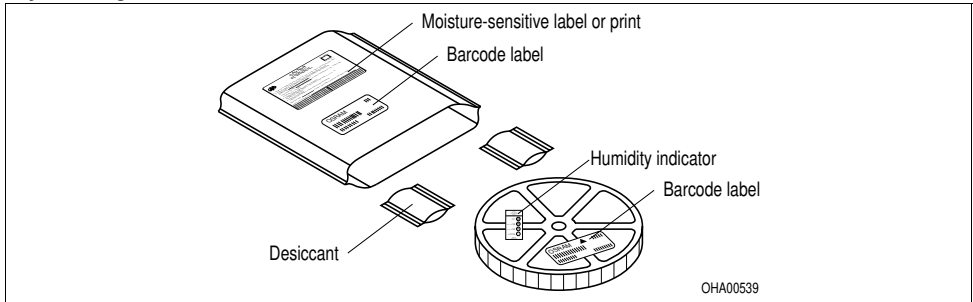

Anm.: Feuchteempfindliche Produkte sind verpackt in einem Trockenbeutel zusammen mit einem Trockenmittel und einer Feuchteindikatorkarte

Bezüglich Trockenverpackung finden Sie weitere Hinweise im Internet und in unserem Short Form Catalog im Kapitel "Gurtung und Verpackung" unter dem Punkt "Trockenverpackung". Hier sind Normenbezüge, unter anderem ein Auszug der JEDEC-Norm, enthalten.

Note: Moisture-sensitive product is packed in a dry bag containing desiccant and a humidity card. Regarding dry pack you will find further information in the internet and in the Short Form Catalog in chapter "Tape and Reel" under the topic "Dry Pack". Here you will also find the normative references like JEDEC.

Kartonverpackung und Materialien

Transportation Packing and Materials

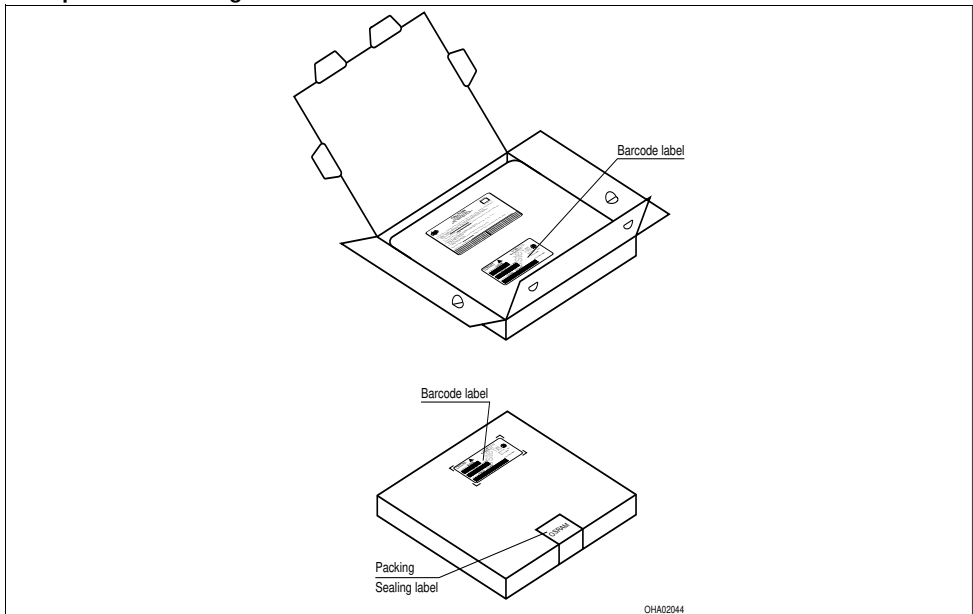

Revision History: 2005-04-05

Previous Version: 2004-03-29

Page	Subjects (changes since last revision)	Date of change
2	luminous intensity	
5	chromaticity coordinate groups	
3	power consumption from 90 to 85 mW	
2	wavelength grouping for white	
9	change of weight from 40 mg to 35 mg	2002-07-05
14	annotations	2002-07-25
13	recomm. solder pad for TOPLED® and Power TOPLED® (OHLPY440)	2002-08-05
3, 4	value (reverse voltage from 5 V to 12 V)	2002-09-18
2	Ordering Code	2002-09-16
3	ambient temperature	2003-09-17
1	ESD-withstand voltage	2003-09-17
15	new patent no.	2003-09-17
all	new template	2003-12-22
all	Discontinuation of non-RoHS compliant product versions	2005-04-05

Patent List**Patent No.**

US 6 066 861
 US 6 277 301
 US 6 245 259
 US 6 576 930

Attention please!

The information describes the type of component and shall not be considered as assured characteristics. Terms of delivery and rights to change design reserved. Due to technical requirements components may contain dangerous substances. For information on the types in question please contact our Sales Organization. If printed or downloaded, please find the latest version in the Internet.

Packing

Please use the recycling operators known to you. We can also help you – get in touch with your nearest sales office. By agreement we will take packing material back, if it is sorted. You must bear the costs of transport. For packing material that is returned to us unsorted or which we are not obliged to accept, we shall have to invoice you for any costs incurred.

Components used in life-support devices or systems must be expressly authorized for such purpose! Critical components⁽¹⁾ page 15 may only be used in life-support devices or systems⁽¹⁾ page 15 with the express written approval of OSRAM OS.

Fußnoten:

- 1) Helligkeitswerte werden mit einer Stromeinprägedauer von 25 ms und einer Genauigkeit von $\pm 11\%$ ermittelt.
- 2) Wegen der besonderen Prozessbedingungen bei der Herstellung von LED können typische oder abgeleitete technische Parameter nur aufgrund statistischer Werte wiedergegeben werden. Diese stimmen nicht notwendigerweise mit den Werten jedes einzelnen Produktes überein, dessen Werte sich von typischen und abgeleiteten Werten oder typischen Kennlinien unterscheiden können. Falls erforderlich, z.B. aufgrund technischer Verbesserungen, werden diese typischen Werte ohne weitere Ankündigung geändert.
- 3) Die LED kann kurzzeitig in Sperrichtung betrieben werden.
- 4) R_{thJA} ergibt sich bei Montage auf PC-Board FR 4 (Padgröße $\geq 16 \text{ mm}^2$ je Pad)
- 5) Farbortgruppen werden mit einer Stromeinprägedauer von 25 ms und einer Genauigkeit von $\pm 0,01$ ermittelt.
- 6) Spannungswerte werden mit einer Stromeinprägedauer von 1 ms und einer Genauigkeit von $\pm 0,1 \text{ V}$ ermittelt.
- 7) Im gestrichelten Bereich der Kennlinien muss mit erhöhten Helligkeitsunterschieden zwischen Leuchtdioden innerhalb einer Verpackungseinheit gerechnet werden
- 8) Maße werden wie folgt angegeben: mm (inch)
- 9) Gehäuse für Wellenlöten (TTW) geeignet.
- 10) Ein kritisches Bauteil ist ein Bauteil, das in lebenserhaltenden Apparaten oder Systemen eingesetzt wird und dessen Defekt voraussichtlich zu einer Fehlfunktion dieses lebenserhaltenden Apparates oder Systems führen wird oder die Sicherheit oder Effektivität dieses Apparates oder Systems beeinträchtigt.
- 11) Lebenserhaltende Apparate oder Systeme sind für
 - (a) die Implantierung in den menschlichen Körper oder
 - (b) für die Lebenserhaltung bestimmt.
 Falls sie versagen, kann davon ausgegangen werden, dass die Gesundheit und das Leben des Patienten in Gefahr ist.

Remarks:

- 1) Brightness groups are tested at a current pulse duration of 25 ms and a tolerance of $\pm 11\%$.
- 2) Due to the special conditions of the manufacturing processes of LED, the typical data or calculated correlations of technical parameters can only reflect statistical figures. These do not necessarily correspond to the actual parameters of each single product, which could differ from the typical data and calculated correlations or the typical characteristic line. If requested, e.g. because of technical improvements, these typ. data will be changed without any further notice.
- 3) Driving the LED in reverse direction is suitable for short term application.
- 4) R_{thJA} results from mounting on PC board FR 4 (pad size $\geq 16 \text{ mm}^2$ per pad)
- 5) Chromaticity coordinate groups are tested at a current pulse duration of 25 ms and a tolerance of ± 0.01 .
- 6) Forward voltages are tested at a current pulse duration of 1 ms and a tolerance of $\pm 0.1 \text{ V}$.
- 7) In the range where the line of the graph is broken, you must expect higher brightness differences between single LEDs within one packing unit.
- 8) Dimensions are specified as follows: mm (inch)
- 9) Package suitable for TTW-soldering.
- 10) A critical component is a component used in a life-support device or system whose failure can reasonably be expected to cause the failure of that life-support device or system, or to affect its safety or the effectiveness of that device or system.
- 11) Life support devices or systems are intended
 - (a) to be implanted in the human body, or
 - (b) to support and/or maintain and sustain human life.
 If they fail, it is reasonable to assume that the health and the life of the user may be endangered.