



Chipsmall Limited consists of a professional team with an average of over 10 year of expertise in the distribution of electronic components. Based in Hongkong, we have already established firm and mutual-benefit business relationships with customers from,Europe,America and south Asia,supplying obsolete and hard-to-find components to meet their specific needs.

With the principle of "Quality Parts,Customers Priority,Honest Operation,and Considerate Service",our business mainly focus on the distribution of electronic components. Line cards we deal with include Microchip,ALPS,ROHM,Xilinx,Pulse,ON,Everlight and Freescale. Main products comprise IC,Modules,Potentiometer,IC Socket,Relay,Connector.Our parts cover such applications as commercial,industrial, and automotives areas.

We are looking forward to setting up business relationship with you and hope to provide you with the best service and solution. Let us make a better world for our industry!



## Contact us

Tel: +86-755-8981 8866 Fax: +86-755-8427 6832

Email & Skype: info@chipsmall.com Web: www.chipsmall.com

Address: A1208, Overseas Decoration Building, #122 Zhenhua RD., Futian, Shenzhen, China



# SYNCHRONOUS BUCK CONVERTER LX1918 EVALUATION BOARD

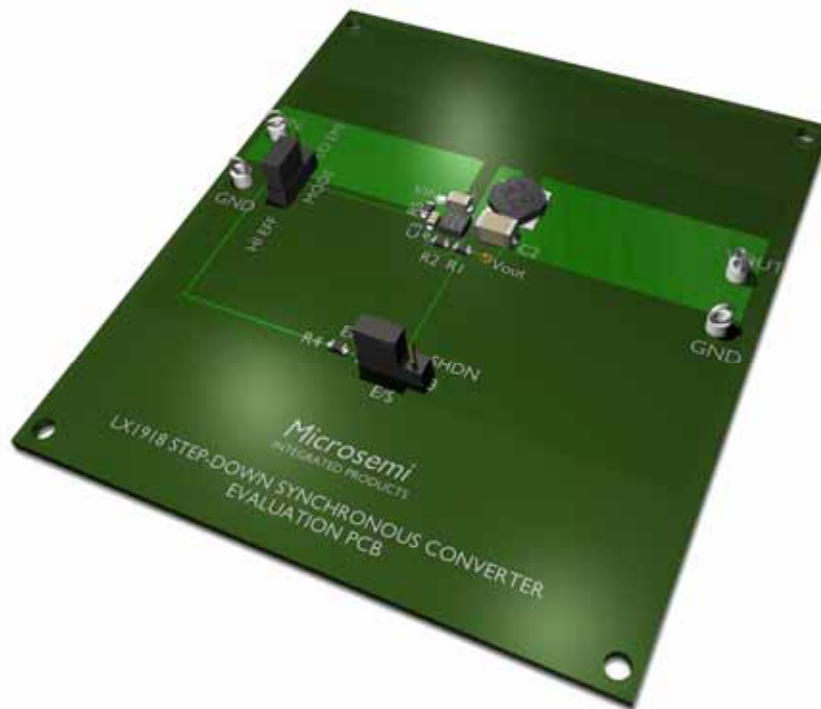

**TABLE OF CONTENTS**

LX1918 EVAL Introduction ..... 3  
Schematic for LX1918 Evaluation Board ..... 4  
Hook Up ..... 5  
Connections ..... 6  
Bill of Materials ..... 6

## INTRODUCING TO PRODUCT

The LX1918 Evaluation Board is available from Microsemi for demonstrating the performance of the LX1918 Synchronous Buck Converter.

## KEY FEATURES

- 2.7V to 6.0V Input Range
- 1.5A Output Current
- 1Mhz free running or 500KHz to 1.25MHz Switching Frequency
- 0.6V Reference Voltage Adjustment
- PFM or PWM Mode
- EMI Support With Force PWM Mode
- Light Load Support:  $I_{OUT} < 300mA$
- $> 95\%$  Efficiency
- Quiescent Current Typical  $400\mu A$
- No External Schottky Diode
- Thermal Shutdown
- Cycle By Cycle Switch Current Limit
- UVLO Protection
- Current Limiting in Hiccup Mode
- 8-Pin MLP package ( $3mm^2$ )

## APPLICATIONS

- Lower Power Embedded Applications
- WLAN Power Systems
- Portable Design with Single Cell Lilon or 3 Cell NiMH / NiCd
- Low Power Portable Storage Application

## PART SPECIFIC INFORMATION

Part Number	Description
LX1918CLD	1.5A Step-Down Synchronous Converter

TABLE 1 – PART INFORMATION

IC	EVALUATION BOARDS
LX1918CLD	LX1918-LD EVAL

TABLE 2 – EVALUATION BOARD INFORMATION

**SCHEMATIC FOR LX1918 EVAL**

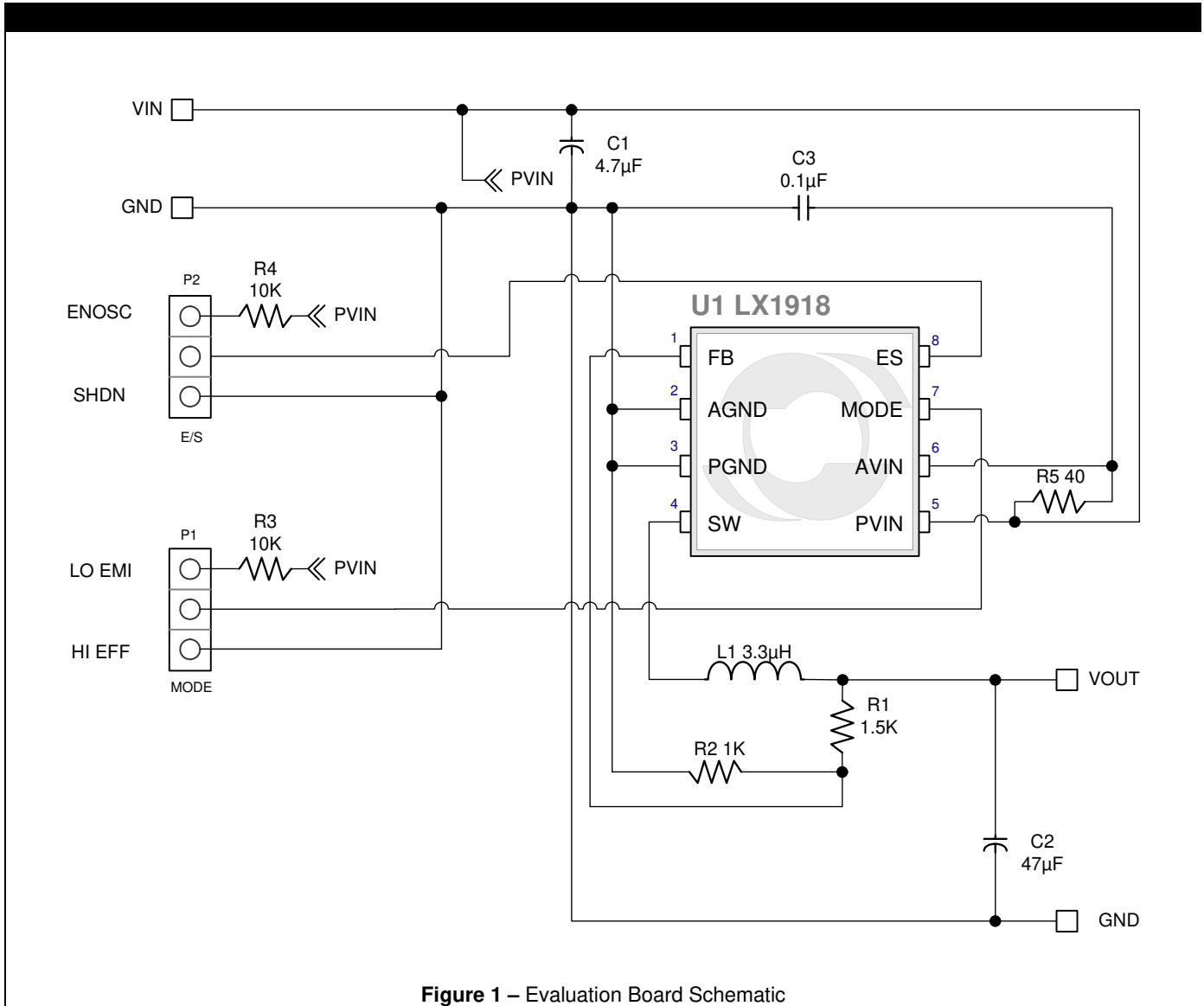

**Figure 1 – Evaluation Board Schematic**

### LX1918 EVALUATION HOOK UP

The following is a demonstration scenario to be used for evaluating the LX1918.

#### HOOK UP DIRECTION

1. Place Mode Jumper in HI EFF (high efficiency) position.
2. Place E/S Jumper in ENOSC position.
3. Apply 3.6V / 2A input between VIN and GND.
4. Connect to Load capable of handling the prescribed output (Board is set to 1.5V output by default).

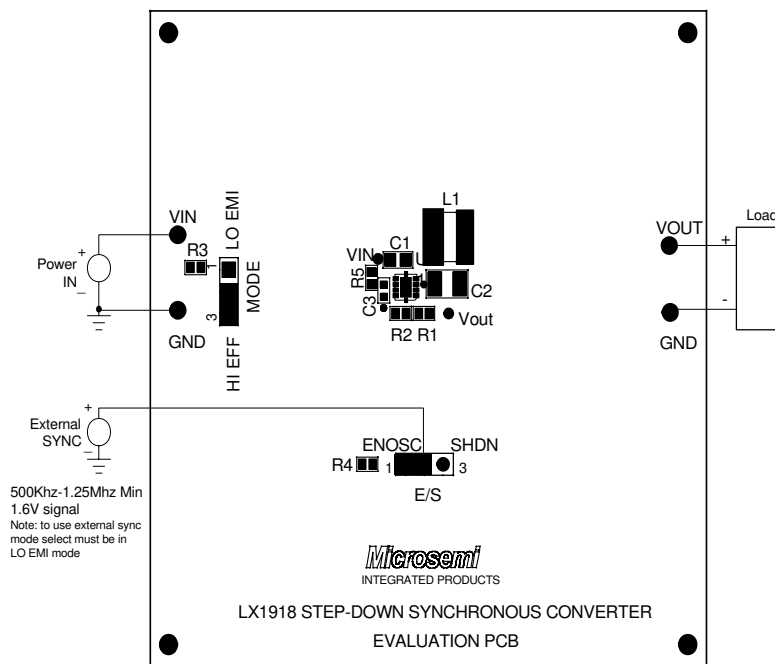

Figure 2 – Evaluation Board Hook Up

## CONNECTIONS

The LX1918 Evaluation board has 4 test lead attachment points for applying power and control signals and for monitoring voltages. There are also 2 – 3 pin connections to select external synchronization

and operating mode. The E/S selector also has shutdown capability

Function	Board Label	Connection
Input Power	VIN	Power Supply (2.70V $\pm$ 6.0V)
Power Ground	GND	Common Power Supply Ground
External Sync / Shutdown	E/S	Connect to GND to disable LX1918. A PWM > 500KHz logic PWM signal can also be applied <sup>1</sup> .
Output Voltage	VOUT	Test Point – Hook up load and monitor VOUT
Mode Select	Mode	High Efficiency = Pin 2 and 3. Low EMI = Pin 1 and 2.

1 – To use external synchronization feature the Mode Select must be in Lo EMI position.

## BILL OF MATERIALS

### MISCELLANEOUS COMPONENTS

Line Item	Part Description	Manufacturer & Part #	Case	Reference Designators	Qty
1	1.5A Synchronous Buck Converter	<b>MICROSEMI</b> LX1918CLD	LD	U1	1
2	Inductor 1.8A Shielded SMD 3.3 $\mu$ H	<b>COILCRAFT</b> MOS6020-332MX		L1	1
3	Header 3 Pin .100			P1, P2	2
4	Test Point – 0.045 diameter, Wire Loop	<b>KEYSTONE</b> 5004_Term			4
5	PCB SGE # 3534 X1				

### CAPACITORS

Line Item	Part Description	Part Description	Case	Reference Designators	Qty
1	Capacitor, 4.7 $\mu$ F, X5R, 10V, 20%	<b>TAIYO YUDEN</b> CELDK212BJ475MG	0805	C1	1
2	Capacitor, 47 $\mu$ F, X5R, 6.3V, 20%	<b>TAIYO YUDEN</b> JMK325BJ476MM	1210	C2	1
3	Capacitor, 0.1 $\mu$ F, X5R, 16V, 20%	<b>TAIYO YUDEN</b> CEEMK107BJ104MA	0603	C3	1

### RESISTORS

Line Item	Part Description	Part Description	Case	Reference Designators	Qty
1	Resistor, 1.5K, 1/16W, 5%	<b>PANASONIC</b> ERJ-3GSYJ152V	0603	R1	1
2	Resistor, 1K, 1/16W, 5%	<b>PANASONIC</b> ERJ-3GSYJ102V	0603	R2	1
3	Resistor, 10K, 1/16W, 5%	<b>PANASONIC</b> ERJ-3GSYJ103V	0603	R3, R4	2
4	Resistor, 40.2, 1/10W, 1%	<b>PANASONIC</b> ERJ-3EKF40R2	0603	R5	1