



Chipsmall Limited consists of a professional team with an average of over 10 year of expertise in the distribution of electronic components. Based in Hongkong, we have already established firm and mutual-benefit business relationships with customers from,Europe,America and south Asia,supplying obsolete and hard-to-find components to meet their specific needs.

With the principle of “Quality Parts,Customers Priority,Honest Operation,and Considerate Service”,our business mainly focus on the distribution of electronic components. Line cards we deal with include Microchip,ALPS,ROHM,Xilinx,Pulse,ON,Everlight and Freescale. Main products comprise IC,Modules,Potentiometer,IC Socket,Relay,Connector.Our parts cover such applications as commercial,industrial, and automotives areas.

We are looking forward to setting up business relationship with you and hope to provide you with the best service and solution. Let us make a better world for our industry!



Contact us

Tel: +86-755-8981 8866 Fax: +86-755-8427 6832

Email & Skype: info@chipsmall.com Web: www.chipsmall.com

Address: A1208, Overseas Decoration Building, #122 Zhenhua RD., Futian, Shenzhen, China



DESCRIPTION

The Microsemi LX1918 is a step down buck regulator with a synchronous rectifier. All MOSFET switches and compensation components are built in. The synchronous rectification eliminates the need of an external Schottky diode and maximizes efficiency (>95%) for a high step-down ratio and a low output voltage. The input supply voltage range is from 2.7V to 5.5V with a maximum output current of 1.8A.

The LX1918 is a current mode PWM with optional PFM under light loads. The LX1918 can switch with a 1MHz free running internal oscillator or be synchronized with an external oscillator ranging from 500KHz to 1.25MHz; the high frequency allows for small size and low cost external components. The LX1918 output voltage is programmable with two resistors and can be tightly regulated down to 0.6V.

The LX1918 MODE feature can either maximize efficiency or reduce EMI depending on the needs of the application. High efficiency (MODE = GND) is obtained by allowing the LX1918 to enter a PFM mode with discontinuous inductor current. Low EMI (MODE=VCC) is obtained by only operating in PWM mode even at no load.

The LX1918 features include soft start, cycle-by-cycle switch current limit, hiccup short circuit current limiting and thermal shut down.

The LX1918 comes in small 8 pin MLP package (fully RoHS compliant).

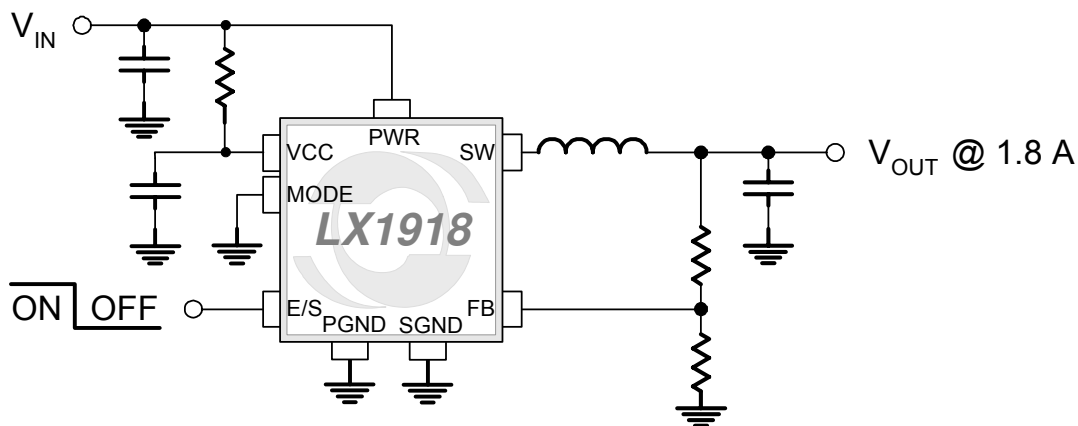
KEY FEATURES

- Input range voltage 2.7 to 5.5V
- Maximum output current, 1.8A
- Internal or External Synchronization
- Output Voltage from V_{IN} to 0.6V
- PFM or PWM mode under light load
- EMI support with force PWM mode
- Efficiency up to 95%
- No external Schottky diode
- Thermal shutdown
- Cycle by cycle switch current limit
- UVLO
- Short circuit protection
- 8 pin MLP

APPLICATIONS

- Lower power embedded applications
- WLAN power system
- Portable design with single cell Lion or 3 cells NiMH/NiCd
- Low power portable storage application

IMPORTANT: For the most current data, consult MICROSEMI's website: <http://www.microsemi.com>

PRODUCT HIGHLIGHT

PACKAGE ORDER INFO

T_A (°C)	LD Plastic MLP
	8-Pin 3x3mm
RoHS Compliant / Pb-free	
-40 to 85	LX1918CLD

Note: Available in Tape & Reel. Append the letters "TR" to the part number.(i.e. LX1918CLD-TR)

ABSOLUTE MAXIMUM RATINGS

Supply Input Voltage (PWR, VCC).....	-0.3V to 6.5V
Supply Input Transient Voltage (PWR, VCC).....	10V
Input Voltage (E/S, FB,MODE)	-0.3V to (V _{CC} + 0.3V)
Maximum Switch Voltage (SW).....	-0.3V to (V _{PWR} + 0.3V)
SW Peak Current (Internally Limited).....	3.6A
Operating Ambient Temperature Range	-40°C to +85°C
Operating Junction Temperature Range.....	-40°C to +125°C
Maximum Operating Junction Temperature	150°C
Storage Temperature Range.....	-65°C to 150°C
Peak Package Solder Reflow Temp. (40 second max. exposure) ...	260°C (+0, -5)

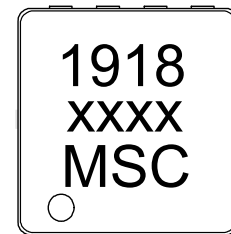
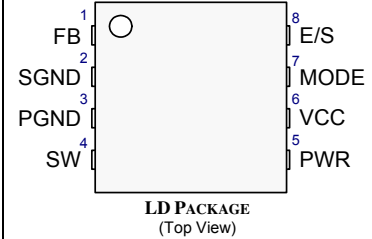
Note: Exceeding these ratings could cause damage to the device. All voltages are with respect to Ground. Currents are positive into, negative out of specified terminal.

THERMAL DATA
LD Plastic MLP 3mm X 3mm 8-Pin

THERMAL RESISTANCE-JUNCTION TO AMBIENT, θ_{JA}	35 – 50°C/W
---	--------------------

Junction Temperature Calculation: $T_J = T_A + (P_D \times \theta_{JA})$.

The θ_{JA} numbers are guidelines for the thermal performance of the device/pc-board system. All of the above assume no ambient airflow. The variation in overall thermal resistance, θ_{JA} , is directly affected by heatsink area available on the PCB.

PACKAGE PIN OUT


RoHS / Pb-free 100% Matte Tin Lead Finish

FUNCTIONAL PIN DESCRIPTION

PIN	Name	Description
1	FB	Feedback Pin - This pin is regulated to the internal reference voltage.
2	SGND	Signal Ground – Low current signal ground reference for IC; also attaches to bottom pad. Connect to common ground reference.
3	PGND	Ground – High current ground; connects to common ground reference.
4	SW	MOSFET Switch (Drain) Connects for inductor.
5	PWR	Power Input – Connect a decoupled voltage source between 2.7V and 5.5V.
6	VCC	Reference power supply for IC.
7	MODE	Light Load Mode Select - Ground for Highest efficiency mode or pull high for Lowest EMI mode during light load operation.
8	E/S	Enable and External Synchronization – Pull high to enable operation with internal oscillator. Apply an external oscillator signal to synchronize the PWM switch frequency. Apply logic low to cause IC to enter Shutdown mode.

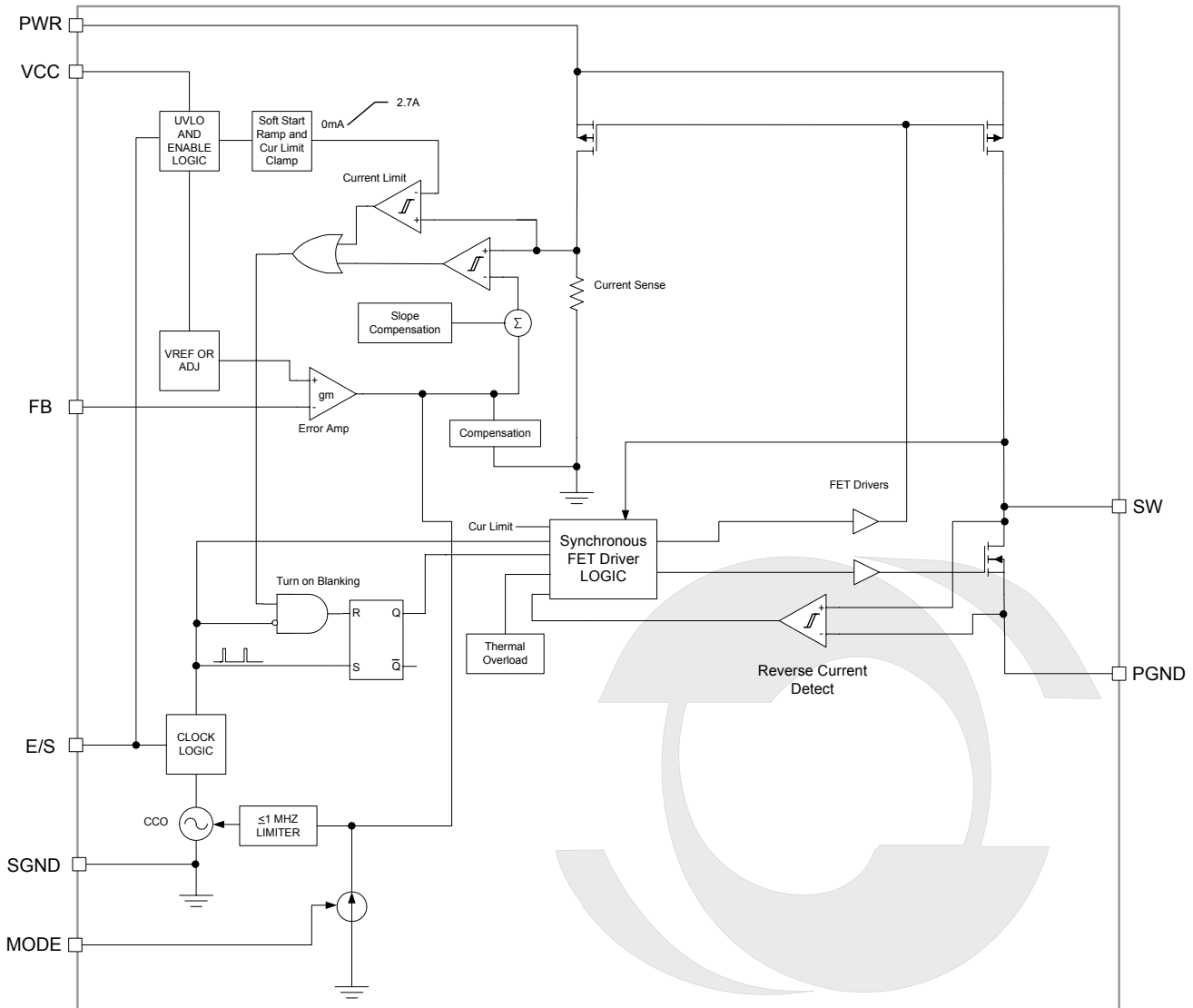
ELECTRICAL CHARACTERISTICS

Unless otherwise specified, the following specifications apply over the operating ambient temperature² $-40^{\circ}\text{C} \leq T_A \leq 85^{\circ}\text{C}$ except where otherwise noted and the following test conditions: $V_{\text{IN}} = 3.7\text{V}$; $V_{\text{E/S}} = 3.7\text{V}$; $V_{\text{MODE}} = \text{GND}$

Parameter	Symbol	Test Conditions	LX1918			Units
			Min	Typ	Max	
ENTIRE REGULATOR						
Input Voltage ³	$V_{\text{PWR}}, V_{\text{CC}}$		2.7		6.0	V
Efficiency ¹	η	$V_{\text{OUT}} = 1.8\text{V}$, $I_{\text{OUT}} = 200\text{mA}$		92		%
Quiescent Current	I_{CC}	$V_{\text{E/S}} = 3.6\text{V}$; $V_{\text{FB}} = 1.0\text{V}$; $T = 25^{\circ}\text{C}$		350	500	μA
		$V_{\text{E/S}} = \text{GND}$		0.5	1.0	
Line Regulation ¹		$V_{\text{IN}} = 2.7$ to 5.5V		1		%
Load Regulation ¹		$I_{\text{OUT}} = 10\text{mA}$ to 1.5A		1		%
Feedback Voltage	V_{FB}		0.588	0.600	0.612	V
FB Input Current	I_{FB}	$V_{\text{FB}} = 0.5\text{V}$ to 0.7V	-50		50	nA
Internal Oscillator frequency	F_{OSC}	$V_{\text{E/S}} = 3.6\text{V}$; $V_{\text{MODE}} = 3.6\text{V}$	0.75	1.00	1.25	MHz
E/S Pin Bias Current		$V_{\text{E/S}} = \text{GND}$		0.1	1.0	μA
E/S Logic High Input	$V_{\text{E/S(HI)}}$		1.6			V
E/S Logic Low Input	$V_{\text{E/S(LO)}}$				0.4	V
SYNC Capture Range		$V_{\text{MODE}} = 3.6\text{V}$	500		1250	kHz
SYNC Minimum Pulse Width		High or Low; $V_{\text{MODE}} = 3.6\text{V}$	100			ns
MODE Bias Current		$V_{\text{E/S}} = \text{GND}$; $V_{\text{MODE}} = V_{\text{IN}}$		1.0	2.0	μA
MODE Logic High	$V_{\text{MODE(HI)}}$		$0.9 \times V_{\text{IN}}$			V
MODE Logic Low	$V_{\text{MODE(LO)}}$				$0.1 \times V_{\text{IN}}$	V
SW Pin Current Limit		Peak Current	2.0	2.7	3.6	A
Thermal Shutdown Threshold ¹			130	140	150	$^{\circ}\text{C}$
Under Voltage Lockout	V_{UVLO}				2.7	V

Notes

1. Guaranteed by design, but not tested.
2. Low duty cycle pulse testing techniques are used which maintains junction and case temperatures equal to the ambient temperature.
3. Functionality over the -40°C to $+85^{\circ}\text{C}$ operating temperature range is assured by design, characterization, and correlation.

SIMPLIFIED BLOCK DIAGRAM

Figure 1 – Simplified Block Diagram

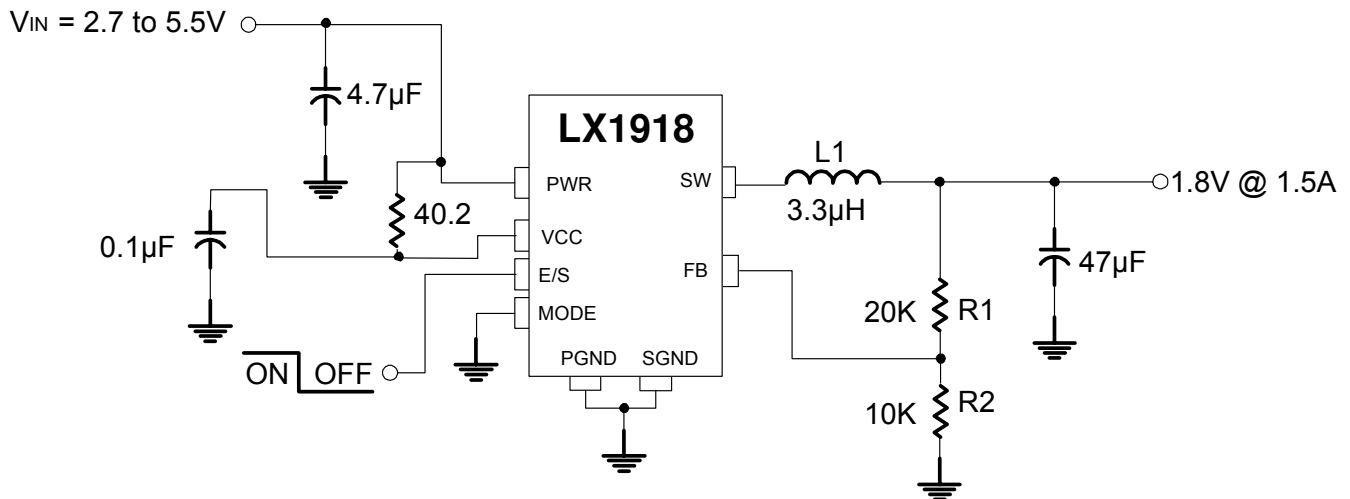
APPLICATION CIRCUITS


Figure 2 – Typical Application: Highest Light Load Efficiency Mode During Light Load With Internal 1MHz PWM Frequency

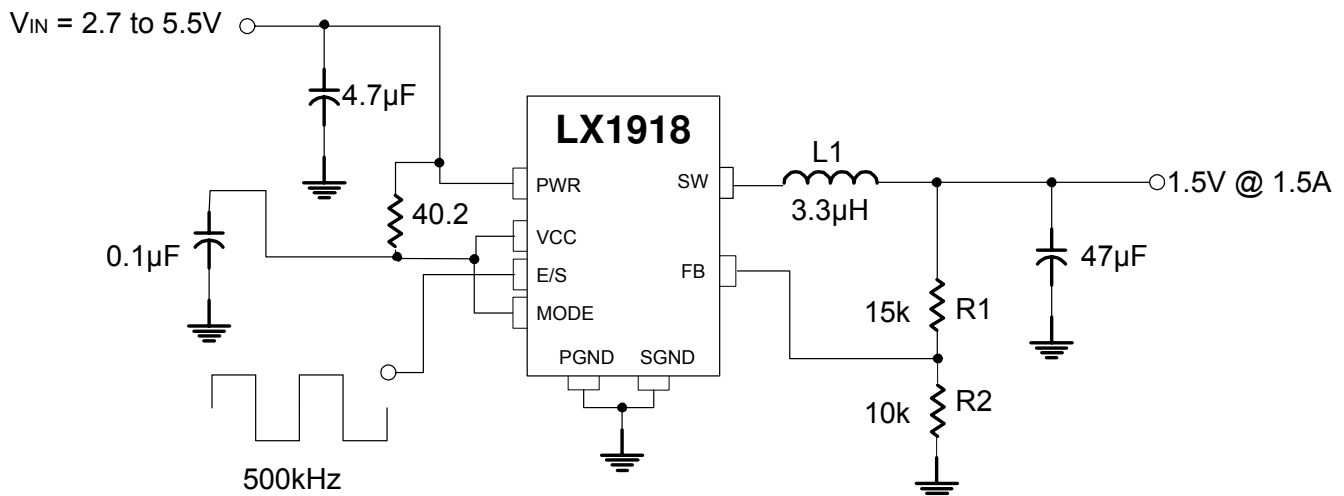


Figure 3 – Typical Application: PWM Low EMI Mode Operation During Light Load With External 500kHz Synchronization

THEORY OF OPERATION

LX1918 is synchronous step down converter with input voltage range from 2.7V to 5.5V; and outputs ranging from 0.6V to 80% of V_{IN} . The LX1918 can deliver a maximum output current up to 1.8A. The LX1918 has two selectable operating modes for light loads: high efficiency PFM (MODE=GND) or low noise forced PWM (MODE=VCC). Under heavy load, LX1918 always operates in PWM mode and switches at fixed internal 1MHz frequency or can be synchronized with an external oscillator clock with a frequency ranging from 500 KHz to 1.25MHz.

Switching frequency

The E/S pin has dual function. If E/S pin pulls HIGH, the 1MHz internal oscillator is enabled. If E/S pin is held LOW, the LX1918 will enter Shut Down mode. Designers can apply an external oscillator signal, 500 KHz to 1.25MHz, to E/S pin to synchronize the switching frequency to a system clock. When applying external oscillator signal, the MODE pin must pull up to VCC activating the forced PWM mode.

High Efficiency Operation: PFM, PWM, and EMI force PWM modes

The LX1918 has two selectable operating modes for light loads: high efficiency PFM (MODE=GND) or low noise forced PWM (MODE=VCC). Only one mode can be active at any time.

Under light load operation, defined as $I_{OUT} < 300mA$, if the MODE pin = VCC, the continuous inductor current mode is selected. This forces fixed frequency PWM and synchronous rectification regardless of loading. The inductor ripple current and duty cycle remain the same, the synchronous rectifier allows the inductor current to go positive or negative preventing system from going into discontinuous conduction and preventing possible EMI associated with inductor ringing.

If MODE pin is LOW, discontinuous current is selected. The PWM frequency slows down as the load decreases and this reduces switching losses. In this mode, the NMOS switch turns off to prevent negative current flow and allows the inductor current to reduce to zero (which is known as discontinuous conduction mode).

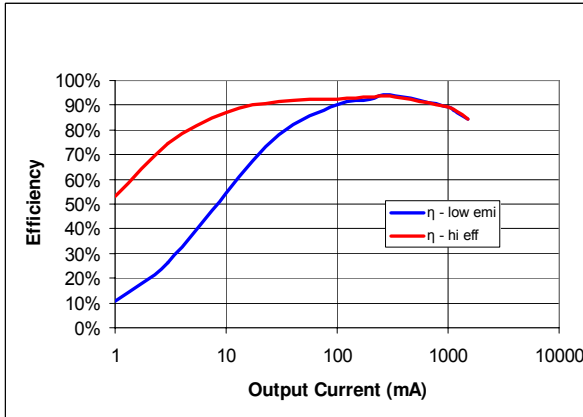
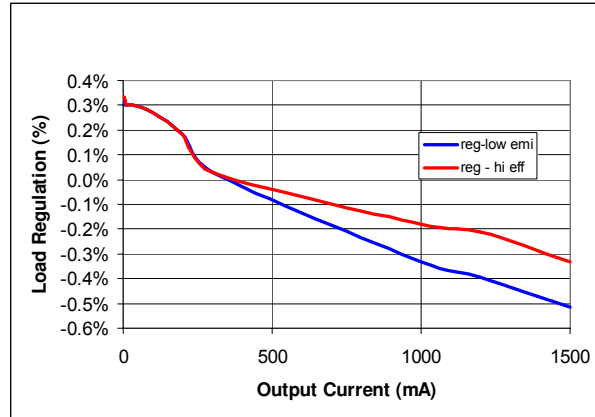
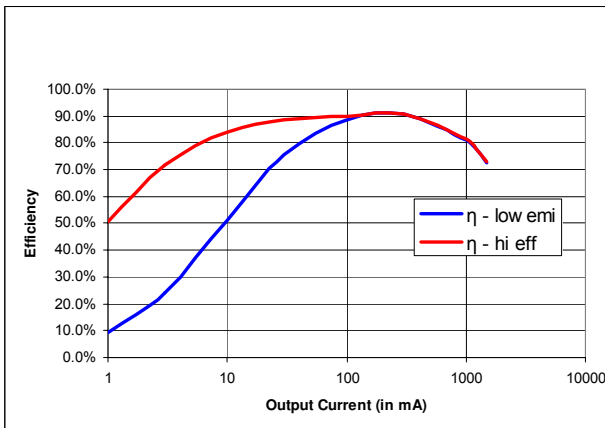
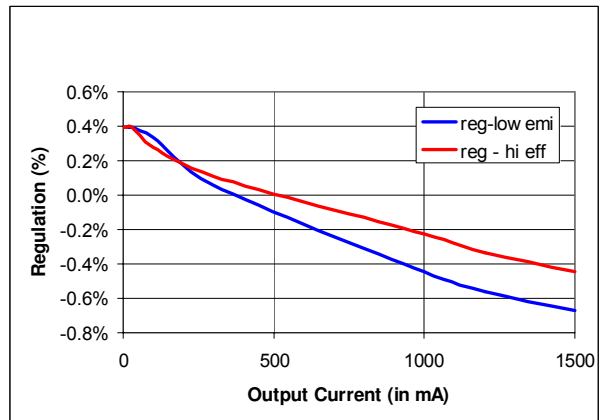
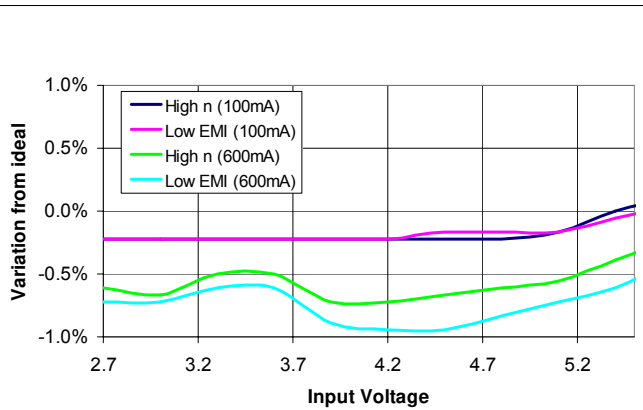
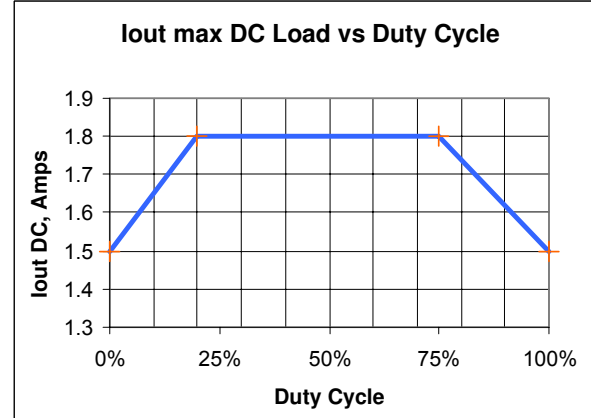
Comparing the efficiency of the two modes of operation under light loading, when $I_{OUT} = 25mA$, LX1918 efficiency is 80% (MODE=GND) and 68% (MODE=VCC).

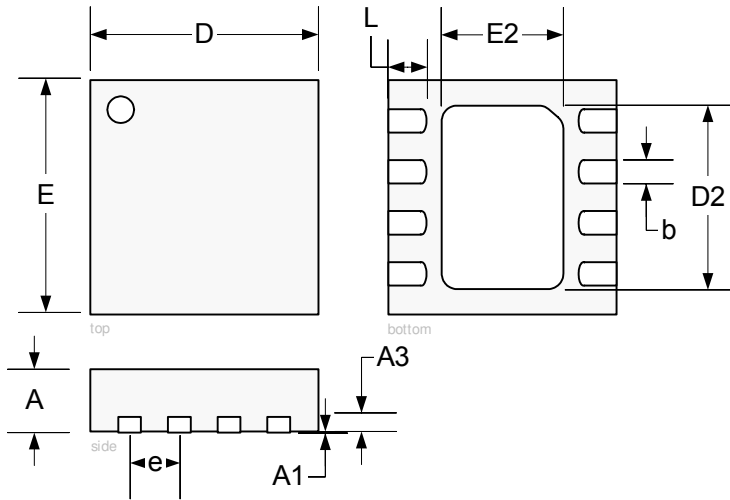
Under heavy load ($I_{OUT} > 500mA$), LX1918 always operates in PWM mode, with an efficiency up to 92%.

Protection:

LX1918 provides thermal shutdown, UVLO, and current limit protection:

- Thermal shutdown: if the die temperature reaches 150°C.
- UVLO: an under voltage lock out, LX1918 will shut down when $V_{IN} < 2.7V$.
- Current limiting protection:
 - Switch current limit: The PMOS switch is limited to a peak current of 2.7A. The PMOS “switch on” cycle is terminated when the switch current limit is reached.
 - Soft start: Upon start up, the switch current is limited to a gradual rise of 0 to 2.7A in 100us. The synchronous rectifier remains off during soft start preventing reverse load current.
 - Hiccup mode: If the PMOS switch is current limited when it attempts to turn on (indicating an output short circuit), the converter will enter a partial soft start cycle mode to prevent a runaway output current.

EFFICIENCY 5V TO 3.3V

REGULATION 5V TO 3.3V

EFFICIENCY 3.3V TO 1.8V

REGULATION 3.3V TO 1.8V

LINE REGULATION (1.8V OUT)

OUTPUT CURRENT VS. DUTY CYCLE


PACKAGE DIMENSIONS
LD
8 Pin Plastic MLP Dual Exposed Pad


Dim	MILLIMETERS		INCHES	
	MIN	MAX	MIN	MAX
A	0.80	1.00	0.0315	0.0394
A1	0	0.05	0	0.0019
A3	0.20	REF	0.0079	REF
b	0.25	0.30	0.010	0.0118
D	3.00 BSC		0.1181 BSC	
D2	1.60	2.50	0.0630	0.0984
e	0.65 BSC		0.0260 BSC	
E	3.00 BSC		0.1181 BSC	
E2	1.35	1.75	0.0531	0.0689
L	0.30	0.50	0.0071	0.0197

Note:

1. Dimensions do not include mold flash or protrusions; these shall not exceed 0.155mm(.006") on any side. Lead dimension shall not include solder coverage.



Microsemi[®]

LX1918

1.8A Step-Down Synchronous Converter

PRODUCTION DATA SHEET

NOTES

PRODUCTION DATA – Information contained in this document is proprietary to Microsemi and is current as of publication date. This document may not be modified in any way without the express written consent of Microsemi. Product processing does not necessarily include testing of all parameters. Microsemi reserves the right to change the configuration and performance of the product and to discontinue product at any time.