



Chipsmall Limited consists of a professional team with an average of over 10 year of expertise in the distribution of electronic components. Based in Hongkong, we have already established firm and mutual-benefit business relationships with customers from,Europe,America and south Asia,supplying obsolete and hard-to-find components to meet their specific needs.

With the principle of "Quality Parts,Customers Priority,Honest Operation,and Considerate Service",our business mainly focus on the distribution of electronic components. Line cards we deal with include Microchip,ALPS,ROHM,Xilinx,Pulse,ON,Everlight and Freescale. Main products comprise IC,Modules,Potentiometer,IC Socket,Relay,Connector.Our parts cover such applications as commercial,industrial, and automotives areas.

We are looking forward to setting up business relationship with you and hope to provide you with the best service and solution. Let us make a better world for our industry!



Contact us

Tel: +86-755-8981 8866 Fax: +86-755-8427 6832

Email & Skype: info@chipsmall.com Web: www.chipsmall.com

Address: A1208, Overseas Decoration Building, #122 Zhenhua RD., Futian, Shenzhen, China



DESCRIPTION

The LX2201 Linear Battery Charger is a multi-state (2 stage) Li-Ion battery charger (Constant current / Constant voltage) that can supply up to 2A of charging current into a single cell Li-Ion battery.

LX2201 is a cost effective, high performance USB battery charger. The LX2201 features a 2A high charge current, with automatic power savings using isolated battery topology, user programmability in USB charging, and an extended battery life with low $R_{DS(ON)}$ in discharge.

In USB mode, the LX2201 has advantages over competition chargers with the USB Limit Control circuit and low $R_{DS(ON)}$ in discharge mode. The USB limit Control circuit allows simultaneous battery charging while the device is in operation. The V_{DD} to supply load is independent of the V_{BAT} charging logic. In discharge mode a low $R_{DS(ON)}$ provides low loss and heavy transient.

The LX2201 is a low cost, highly integrated battery charger solution. It only requires three external resistors: one for setting the constant charge current level, one for setting the termination charge current, and one for setting V_{IN} . It also has a built in thermostat that will throttle back the charge current to keep the die temperature from exceeding 150°C; this feature insures the LX2201 delivers the maximum charge rate for a given thermal environment.

IMPORTANT: For the most current data, consult MICROSEMI's website: <http://www.microsemi.com>
Patent Pending

LX2201 support two types of Li-Ion battery chemistry; 4.1V and 4.2V through logical input (VM pin).. A high accuracy current sensing circuit allows batteries to be fully charged before terminating the charge cycle. The LX2201 design enhances system battery life by avoiding premature discharge of Li-Ion battery with a separate battery terminal voltage from system load when adaptor charging is used, i.e. trickle charge.

The LX2201 provides a charging status indicator. The integrated PMOS pass element features low drop out voltage while providing an inherent load disconnect with virtually no drain on the battery when disabled or when the input power is removed. Additionally a battery load disconnect switch has been integrated which provides seamless power switching when transitioning between charge and discharge modes.

The LX2201 features a pre-charge conditioning mode for batteries that have been deeply discharged and also has a top off charge mode for batteries that are left on the charger for extended periods.

The LX2201 is available in a high power 4mm x 4mm, 20-pin MLP, surface mount package.

KEY FEATURES

- 2A Charge Current
- USB Compliant Charging States
- Low $R_{DS(ON)}$ in Discharge Mode
- Power Saving and Conditional Mode for Deep Discharge
- Selectable Li-Ion Battery for 4.1V or 4.2V Applications
- Internal Pass Element Can Function as a Reverse Direction Load Switch
- No Sense Resistor Required
- Full Capacity Charging
- True Charge Indicator
- Wall Supply Regulator Tolerance 5V + 10%
- Built In MOSFET Driver For Easy AC Adapter/USB Implementation
- Topping Charge with Voltage Monitoring Mode
- Inherent Load Disconnect
- Small, High Power 20-lead MLP package

APPLICATIONS

- Batteries with 350mAH to 2AH Ratings
- Cell Phones
- PDAs
- Charging Cradles
- Digital Cameras
- Low Cost Single Li-Ion Cell Chargers

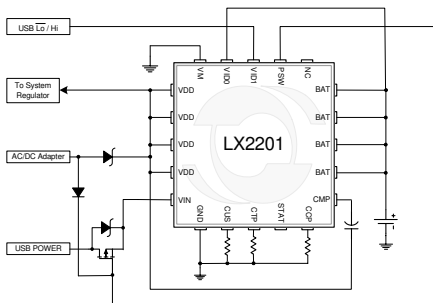
PRODUCT HIGHLIGHT

State Select Truth Table

VID0	VID1	$V_{DD} > V_{BAT}$	$V_{BAT} > V_{DD}$
0	0	Switch open – charging disabled.	Switch open – discharge disabled.
0	1	Charging – USB high level if using V_{IN} .	Switch open – discharge disabled.
1	0	Charging – USB low level if using V_{IN} .	Battery Discharging. MOSFET fully enhanced with current flow V_{BAT} to V_{DD} .
1	1	Charging – USB high level if using V_{IN} .	Battery Discharging. MOSFET fully enhanced with current flow V_{BAT} to V_{DD} .

PACKAGE ORDER INFO

T_A (°C)	LQ Plastic MLP 4x4mm 20-Pin RoHS Complaint / Pb-free
0 to 70	LX2201CLQ

Note: Available in Tape & Reel.
Append the letters "TR" to the part number.
(i.e. LX2201CLQ-TR)

ABSOLUTE MAXIMUM RATINGS

Supply Voltage (VIN).....	-0.3V to 7V
Analog Input Signals (VIDx, VM, SNS)	-0.3V to 7V
Battery Charging Current (IBAT).....	2A
Discharge Current (IVDD).....	3A
Operating Junction Temperature.....	150°C
Storage Temperature Range.....	-65°C to 150°C
Peak Package Solder Reflow Temp. (40 second max. exposure) ...	260°C (+0, -5)
VIN Maximum DC Current.....	500mA
VIN Maximum Surge Current.....	2A

Note: Exceeding these ratings could cause damage to the device. All voltages are with respect to Ground. Currents are positive into, negative out of specified terminal.

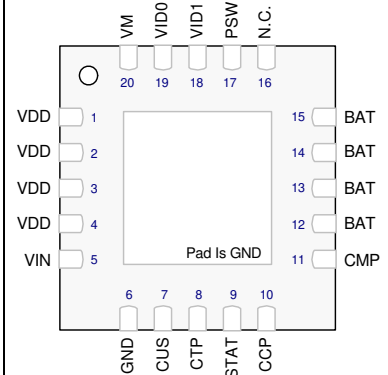
PACKAGE PIN OUT

LQ PACKAGE
(Top View)

N.C. – No Internal Connection

RoHS / Pb-free 100% Matte Tin Lead Finish

THERMAL DATA
LQ Plastic Micro Lead Frame Quad Package 20-Pin
THERMAL RESISTANCE-JUNCTION TO AMBIENT, θ_{JA}
40°C/W

 Junction Temperature Calculation: $T_J = T_A + (P_D \times \theta_{JA})$.

 The θ_{JA} numbers are guidelines for the thermal performance of the device/pc-board system. All of the above assume no ambient airflow.

FUNCTIONAL PIN DESCRIPTION

Name	Description
BAT	Charging Output - This pin is wired to the positive terminal of the battery. (The negative battery terminal is wired to GND.)
CCP	Charge Current Programming Pin - A resistor (RCP) is connected between this pin and GND. The constant current is determined by the following relationship: $I_{BAT(MAX)} = \frac{65000}{RCP}$
CMP	Compensation Pin – Connect a 0.1 uF compensation capacitor from this pin to VDD.
CTP	Charge Termination Programming Pin – A resistor (RTP) is connected between this pin and GND. The termination charge current is determined by the following relationship: $I_{BAT(MIN)} = \frac{7500}{RTP}$
CUS	Maximum VIN Current Programming Pin – A resistor (RUS) is connected between this pin and GND. The Hi Level charge current is determined by the following relationship: $I_{INH(HI)} = \frac{1211}{RUS}$
GND	Common Ground
NC	Not Connected. This pin is connected internally and should be left floating.
PSW	PMOS Switch driver – This output is designed to drive the gate of an external PMOS power switch. The driver is pulled low (PMOS on state) when $V_{DD} > V_{BAT}$.
VDD	Common Power Node – Connects to system power bus.
VIDx	State Select Input – Applying a two bit TTL compatible signal sets the desired state of the charger corresponding to the Truth Table.
VIN	Voltage Input – Current limited USB input. Apply a USB compliant power input.
VM	Voltage Mode Select - Selects the constant voltage. VM = Low to select 4.2V charge level. VM = High to select 4.1V charge level.
STAT	Status - This pin is a logic high level when the battery is being charged. A low signal indicates either under voltage lockout, charge completed, or $V_{BAT} > V_{DD}$, or $VID0 = VID1 = 0$.

ELECTRICAL CHARACTERISTICS

Unless otherwise specified, the following specifications apply over the operating ambient temperature $0^{\circ}\text{C} \leq T_A \leq 70^{\circ}\text{C}$ except where otherwise noted and the following test conditions: $V_{DD} = 5.0\text{V}$.

Parameter	Symbol	Test Conditions	LX2201			Units
			Min	Typ	Max	
MAIN CIRCUITRY						
Input Voltage	VDD		4.5		6	V
Quiescent Current	I _{GND}	VDD > V _{BAT}		4	8	mA
		VDD < V _{BAT}		3	5	μA
CTP Bias Voltage	V _{CTP}	R _{CTP} = 150K, I _{BAT} > 100mA		1.25		V
CCP Bias Voltage	V _{CCP}			1.25		V
CUS Bias Voltage	V _{CUS}			2.6		V
CONSTANT VOLTAGE MODE						
Constant Voltage Charge Level	V _{CVL}	VM = Low	4.16	4.2	4.24	V
		VM = High	4.06	4.1	4.14	V
Maximum Dropout Voltage	V _{IN} - V _{BAT}	I _{BAT} = 1A			350	mV
Top Off Charge Droop Threshold	V _{DRP}		96	97	98	% V _{BAT} /V _{CVL}
CONSTANT CURRENT MODE						
BAT Constant Current Accuracy	I _{CCL}	R _{CCP} = 64.9K	0.85	1	1.15	A
BAT Constant Current Level	I _{BAT}	V _{BAT} < (V _{CVL} - 100mV)	0.35		2	A
Conditioning Current	I _{COND}	V _{BAT} < V _{CTV} ; @25°C	3.0	4.75	6.0	% I _{BAT} /I _{CCL}
Conditioning Current Mode Threshold Voltage	V _{CTV}		60	64	68	% V _{BAT} /V _{CVL}
Charge Termination Current Accuracy	I _{BAT}	R _{CTP} = 150K; @25°C	35	50	65	mA
USB CURRENT LIMIT						
USB Low Current Limit	I _{IN}	V _{IN} = 5V, VDD < V _{IN} , VID1 = Lo, R _{USB} = 2.55K	85	93	100	mA
USB High Current Limit	I _{IN}	V _{IN} = 5V, VDD < V _{IN} , VID1 = Hi, R _{USB} = 2.55K	425	463	500	mA
LOGIC						
STAT Logic High Output	V _{STAT}	V _{IN} = 5.0V, I _{STAT} = -5mA		4.5	5	V
STAT Logic Low Output	V _{STAT}	V _{IN} = 5.0V, I _{STAT} = 25μA			0.4	V
State Select Threshold	V _{VID}	Logic High	2.0			V
		Logic Low			0.8	V
VM Select Threshold	V _{VM}	Logic High	2.0			V
		Logic Low			0.8	V
THERMAL SHUTDOWN						
Maximum Junction Temperature	T _J	V _{IN} = 5.0V, I _{OUT} = 1A, Temperature Rising	130	140	150	°C
BI-DIRECTIONAL PASS ELEMENT CONTROL						
Discharge Switch On Resistance	R _{DS(ON)}	I _{BAT} = -1A		130	150	mΩ
Charging Threshold	V _{CHG}	V _{IN} > V _{BAT} + V _{CHG}	0	5	10	mV
Discharging Threshold	V _{DCH}	V _{IN} > V _{BAT} + V _{DCH}	0	5	10	mV
Pass Element Switch Mode Delay	t _{SW}	Charge-to-discharge or Discharge-to-charge		5		μs
PSW FET DRIVER						
High Output Voltage	V _{PSW}	V _{IN} < V _{BAT} , I _{PSW} = 0, V _{BAT} = 4.2V	4.1	4.2		V
Low Output Voltage	V _{PSW}	V _{IN} > V _{BAT} , I _{PSW} = 0		0	0.2	V
OR-ing Resistance	R _{PSW}		5	10	15	KΩ
Switch Delay (VDD > V _{BAT} to VDD < V _{BAT})	t _{PSW}	C _{PSW} = 1000pF, to V _{PSW} = (V _{BAT} - 1V)	0	500	1000	Ns

SIMPLIFIED BLOCK DIAGRAM

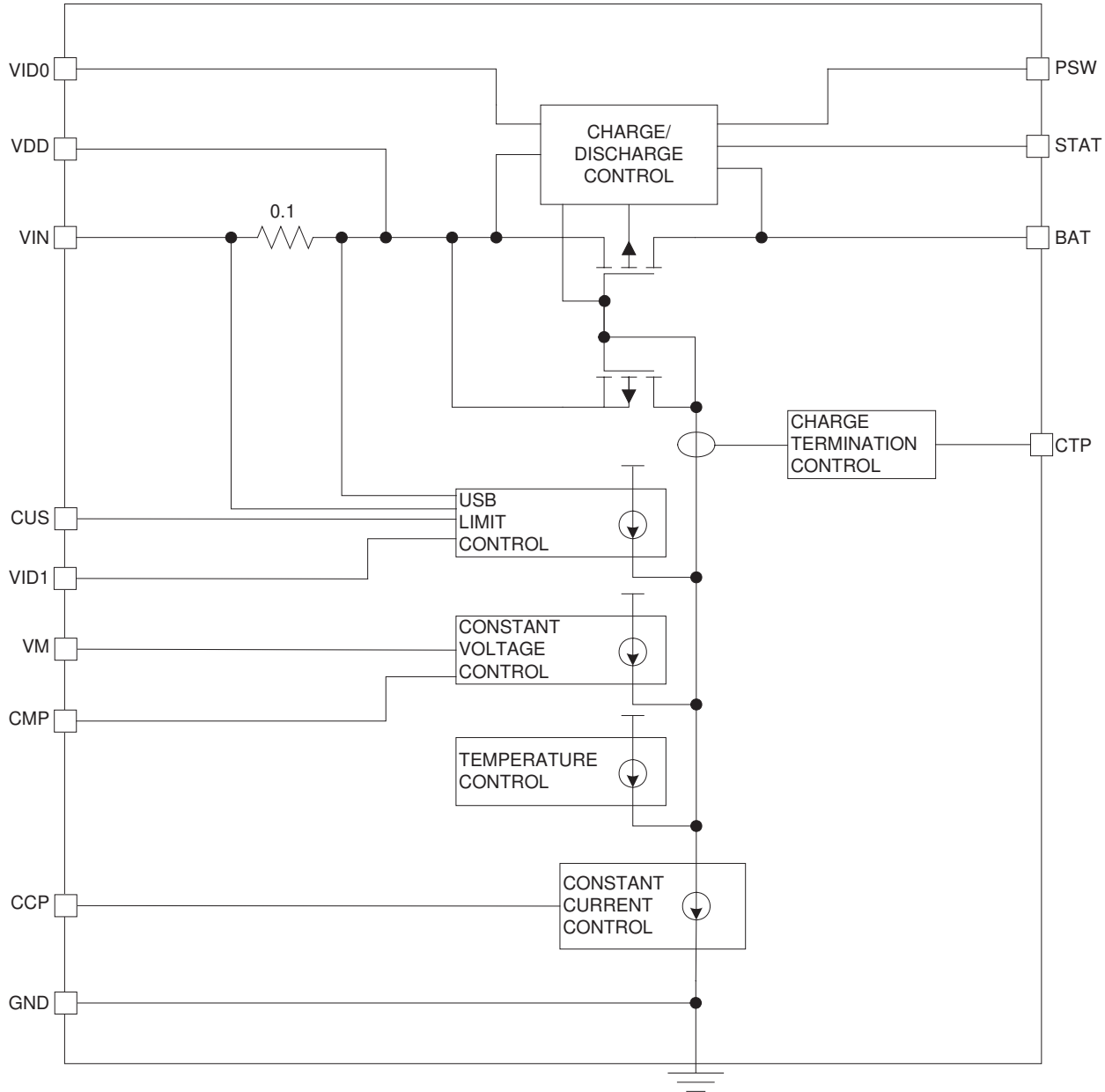
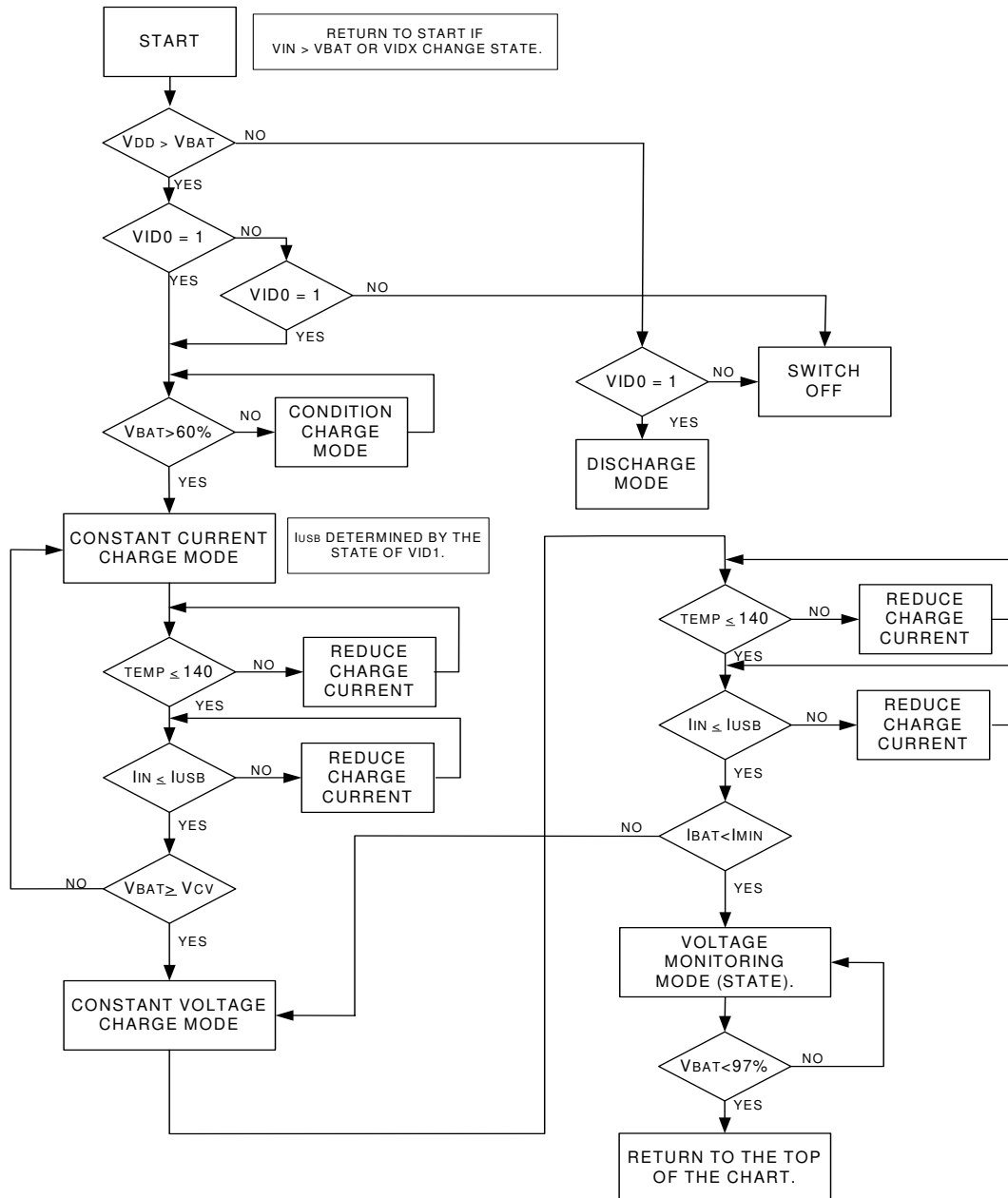

Figure 1 – Simplified Block Diagram

APPLICATION CIRCUITS
LX2201 CONTROL FLOW DIAGRAM

Figure 2 – Control Flow Diagram

APPLICATION SCHEMATICS

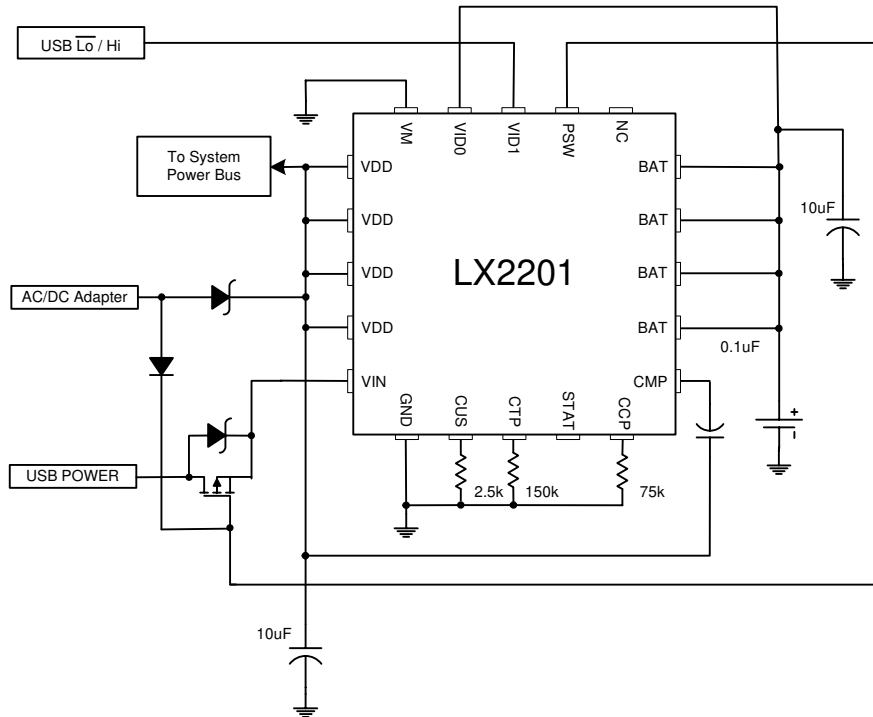

Figure 3 – AC Adapter and USB Supply (Charge and Discharge Modes)

APPLICATION SCHEMATICS (CONTINUED)

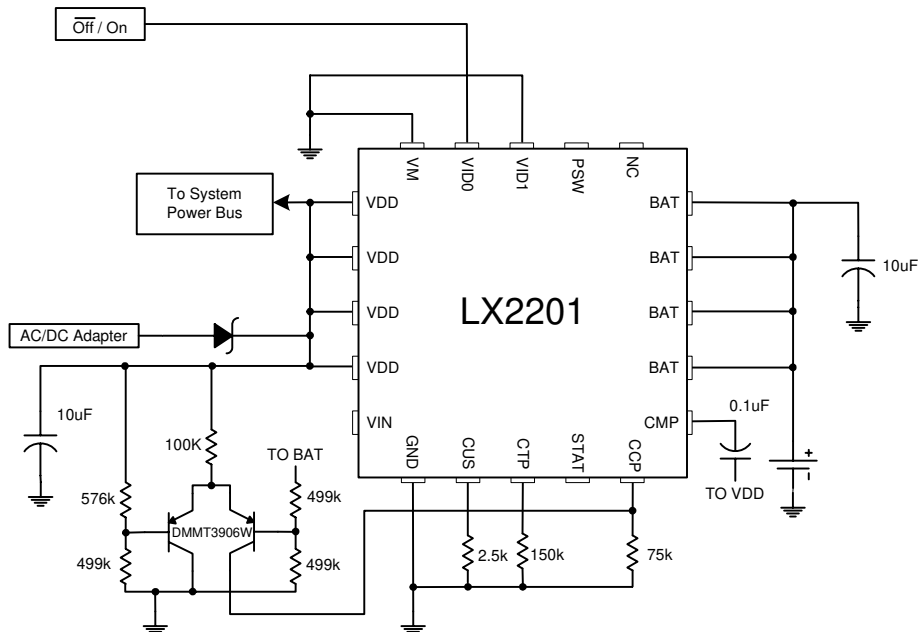

Figure 4 – AC Adapter with charging voltage headroom regulation (for use with a current limited power supply)

USB Li-Ion Battery Charger

PRODUCTION DATA SHEET

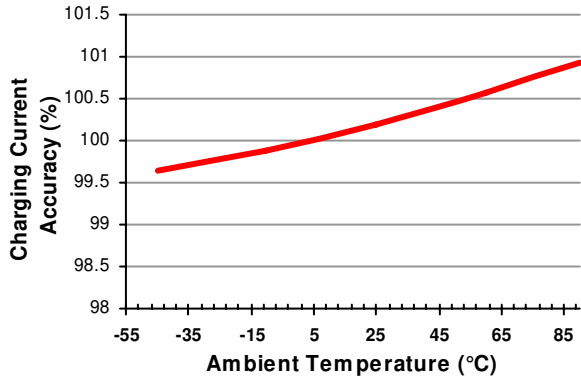

Chart 1 – Charging Current Accuracy over Temperature

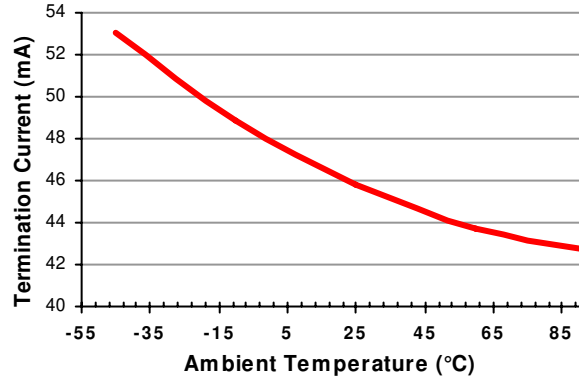

Chart 2 – Termination Current over Temperature

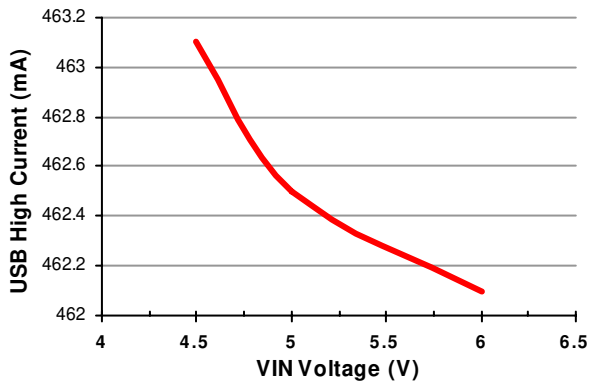

Chart 3 – USB High Current over VIN Voltage

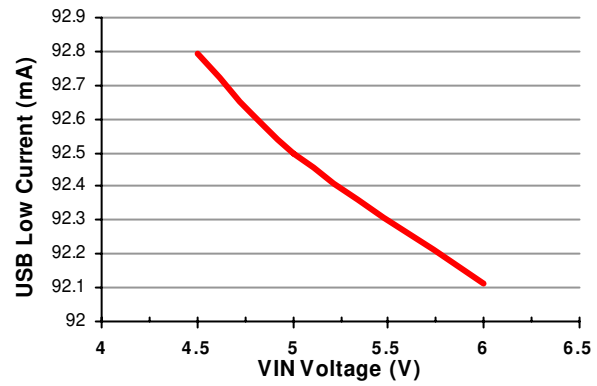

Chart 4 – USB Low Current over VIN Voltage

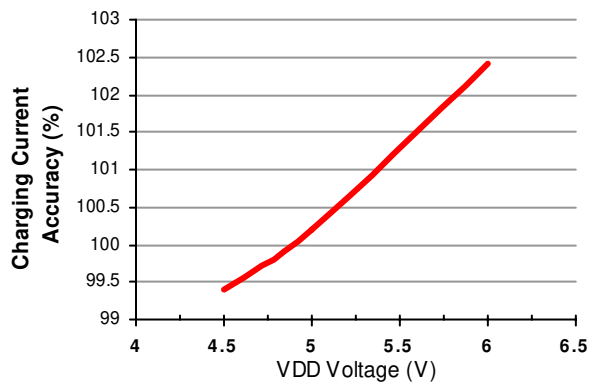

Chart 5 – Charging Current over VDD Voltage

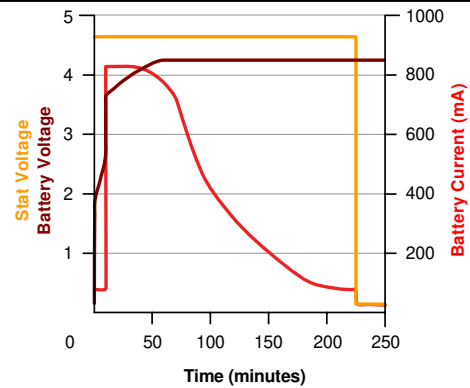

Chart 6 – Battery Current & Voltage vs. Time

THEORY OF OPERATION**GENERAL DESCRIPTION**

The LX2201 is designed to charge a single cell Lithium Ion battery using two steps: a constant current step followed by a constant voltage step. The basic charger function uses the VDD pins as an input and BAT pins as the output. The LX2201 charger has a programmable maximum current (programmable by the resistor value between pin CCP to GND) which is the maximum charging current during the Constant Current Mode of the charging profile. The low dropout of the pass element allows the battery to be charged from a loosely regulated power supply. In the Constant Voltage Mode, the battery terminal voltage can be regulated to 4.1V or 4.2V by strapping the VM pin to VDD or GND, respectively. The charger will terminate constant voltage charging once the current drops below the minimum current setting (programmable by the resistor value between pin CTP to GND).

The LX2201 has an integrated thermostat with a linear thermal regulation loop that will throttle back the charging current to prevent the internal die temperature from exceeding 150°C. This feature prevents damage to the system board when the IC exceeds its thermal temperature.

CURRENT CHARGE MODE

A conditioning current is applied to batteries that are deeply discharged and have a terminal voltage less than 60% of the constant voltage level. The conditioning current is 5% of the CCP programmable constant current level (except where it might be limited in the USB states). Once the battery terminal voltage exceeds the 60% level, the full constant current level is applied (unless charging current is limited by one of the other charger control loops).

CHARGE TERMINATION MODE

To increase system battery life and avoid float charging, the LX2201 turns off the pass element once the battery has been fully charged. The charge termination state occurs at the end of constant voltage mode. The charge status changes state when charging is completed.

TOP OFF CHARGE MODE

Once the charger has completed a charge cycle, if power remains applied, the LX2201 enters a Voltage Monitoring mode. In this mode the LX2201 monitors the battery terminal voltage and applies a top off charge if the battery voltage drops by more than 3% of full scale. This feature is especially important for charging systems in equipment where usage is infrequent.

USB CHARGE MODE

The LX2201 is fully compliant with, and supports, the USB specifications – the Low Power Peripheral (100mA) and High Power Peripherals (500mA). VID1 logic input selects USB charge currents. The LX2201 senses the current flowing from the VIN terminal to the VDD terminal; then it limits the VIN current by reducing the current flowing from V_{DD} to V_{BAT}. Note: the USB Charge Limit circuit does not limit the input current and only scales the charging current.

DISCHARGE MODE

In discharge mode, VID0 is, indicate discharge mode enable. The system load is connected to VDD. The input power is connected to VDD through an internal diode. When the input power is removed, the battery current flows from V_{BAT} to VDD. The circuit of Figure 3 shows the LX2201 in a discharge mode configuration with both AC adapter and USB inputs. The USB input is diode ORed to the VDD pin and uses a MOSFET to reduce the diode drop across the ORing diode. The LX2201 provides a signal “PSW” to control the MOSFET for charge and discharge modes. When both AC and USB power are applied the PSW signal is overridden by the AC adapter diode and the MOSFET is turned off



APPLICATION NOTE

CURRENT LIMITED POWER SUPPLIES

When using input power supplies that are current limited or have high source impedance, the battery charging current and/or load current can pull the VDD pin down very close to the battery terminal voltage. This may cause the LX2201 to enter an indeterminate state where it switches between charge and discharge modes. To prevent this, the PNP differential amplifier circuit of figure 4 can be added; this circuit adds an additional control loop that regulates the charger headroom to 300mV by scaling back the battery charging current.

The internal power switch within the LX2201 requires the power supply have a minimal level of strength to switch from discharge mode to charge mode. If the power source is severely current limited, the LX2201 may not open the discharge switch. In this case, a small amount of current will be allowed to flow into the battery unregulated. If left in this state indefinitely, the current will eventually raise the battery terminal voltage to the point where the batteries internal protection circuitry will open the circuit. Typically, the LX2201 requires a minimum of 80mA in USB mode and 200mA using the VDD input to force the switchover to charge mode. Alternatively, if weak power sources are used, the switchover from discharge to charge mode can be forced by momentarily setting VID0 and VID1 to a low state, which will open the discharge switch allowing the VDD voltage to rise so the LX2201 can enter charge mode.

USB COMPLIANCE

To be compliant with the USB specification, the +5V current must be less than 100mA in the low power mode and less than 500mA in the high power mode. If the LX2201 is configured as shown in Figure 3, it is possible for the system to consume more than the maximum allowed USB current (in which case the battery charging current will have been fully scaled back). If it is not possible to regulate the load current when charging from a USB power source and strict adherence to the USB power budget is required. In this case the system load can be applied directly to the battery and the LX2201 will prevent the load + battery from drawing more power than is allowed for USB compliance. A better approach that provides battery isolation may be used; in this approach, the op amp circuit provides a current limiter that prevents the system from exceeding the USB power limits. The battery is only discharged if the AC adapter or USB inputs are removed or current limited.

LAYOUT GUIDELINES

- It is important when laying out the LX2201 to place 10µF ceramic capacitors close to the VDD and V_{BAT} IC terminals to filter switching transients.
- It is important to provide a low thermal impedance path from the thermal pad on the bottom of the LX2201 package to the ground plane of the circuit board to maximize the heat dissipation.

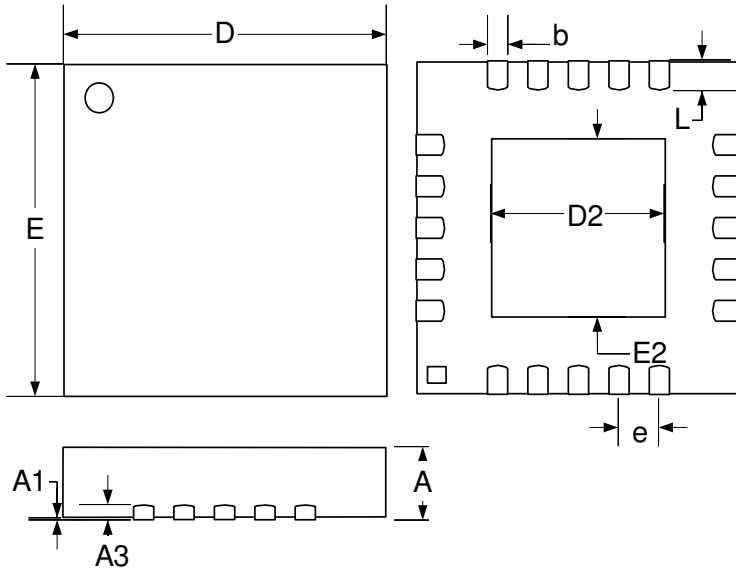
PACKAGE DIMENSIONS
LQ 20-Pin MLPQ Plastic 4x4mm (114x114DAP)

Dim	MILLIMETERS		INCHES	
	MIN	MAX	MIN	MAX
A	0.80	1.00	0.031	0.039
A1	0.00	0.05	0.000	0.002
A3	0.20	REF	0.008	REF
b	0.18	0.30	0.007	0.088
D	4.00	BSC	0.157	BSC
D2	2.59	2.79	0.102	0.110
E	4.00	BSC	0.157	BSC
E2	2.59	2.79	0.102	0.110
e	0.50	BSC	0.019	BSC
L	0.30	0.50	0.011	0.019



MicrosemiTM

Not Recommended for New Design: See the LX2202

LX2201

USB Li-Ion Battery Charger

PRODUCTION DATA SHEET

NOTES

PRODUCTION DATA – Information contained in this document is proprietary to Microsemi and is current as of publication date. This document may not be modified in any way without the express written consent of Microsemi. Product processing does not necessarily include testing of all parameters. Microsemi reserves the right to change the configuration and performance of the product and to discontinue product at any time.