



Chipsmall Limited consists of a professional team with an average of over 10 year of expertise in the distribution of electronic components. Based in Hongkong, we have already established firm and mutual-benefit business relationships with customers from,Europe,America and south Asia,supplying obsolete and hard-to-find components to meet their specific needs.

With the principle of "Quality Parts,Customers Priority,Honest Operation,and Considerate Service",our business mainly focus on the distribution of electronic components. Line cards we deal with include Microchip,ALPS,ROHM,Xilinx,Pulse,ON,Everlight and Freescale. Main products comprise IC,Modules,Potentiometer,IC Socket,Relay,Connector.Our parts cover such applications as commercial,industrial, and automotives areas.

We are looking forward to setting up business relationship with you and hope to provide you with the best service and solution. Let us make a better world for our industry!



Contact us

Tel: +86-755-8981 8866 Fax: +86-755-8427 6832

Email & Skype: info@chipsmall.com Web: www.chipsmall.com

Address: A1208, Overseas Decoration Building, #122 Zhenhua RD., Futian, Shenzhen, China



LX2208 THREE LEVEL BATTERY CHARGER (2A MAXIMUM)

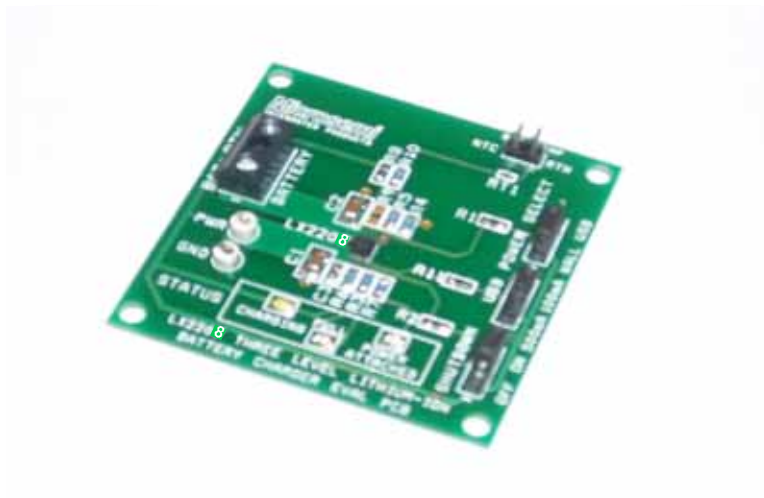

INTRODUCING TO PRODUCT

The LX2208 Evaluation Board is available from Microsemi for evaluating the performance of the LX2208 Battery Charger Integrated Circuit. The component sizes used on the evaluation board facilitate easy probing, however, in practice, smaller component sizes are recommended to minimize the circuit physical size.

KEY FEATURES

- Up to 2A Charging Current
- Integrated Power MOSFET
- Three Charge Levels for Adapter, and USB Hi and Low
- Charge Battery from a Current Limited Adapter
- 0.5% Battery Voltage Accuracy
- USB Current Compliance
- Battery Full Indicator
- CC/CV with Thermal Feedback
- Battery Temperature Monitor
- Precision Charge Termination

- **Protection features:**
 - Unsafe Battery Temp Lockout
 - Internal IC Temp Regulator
 - USB Current Limiter
 - Reverse Current Blocking
 - Under Voltage Lockout
 - False Termination Prevention under Low Supply Conditions

APPLICATIONS

- Navigation Devices
- Multi-Media Players
- Handheld Devices
- Digital Cameras

PART SPECIFIC INFORMATION

Part Number	Product
LX2208ILD	Three Level Lithium Ion Battery Charger

TABLE 1 – PART INFORMATION

IC	EVALUATION BOARDS
LX2208ILD	LX2208 EVAL KIT

TABLE 2 – EVALUATION BOARD INFORMATION

SCHEMATIC FOR LXE

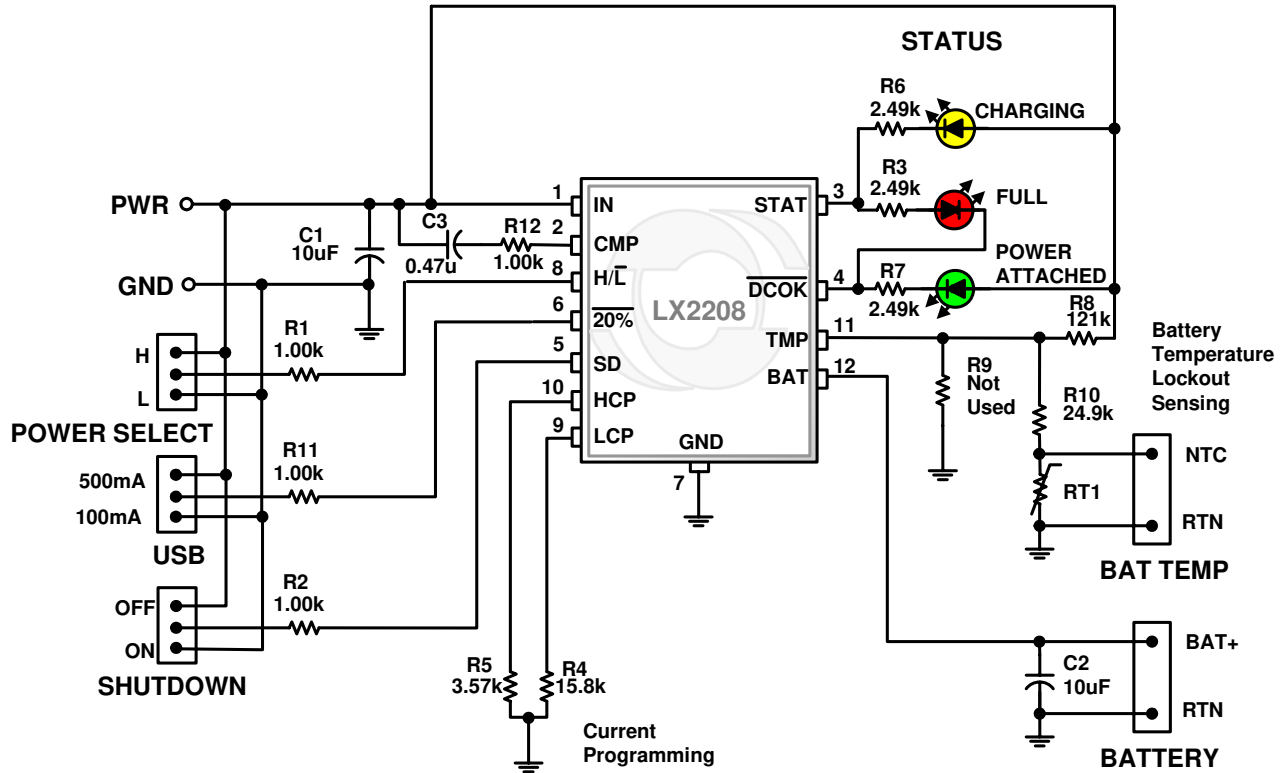

Figure 1 – LX2208 Evaluation Board Schematic

IC BLOCK DIAGRAM

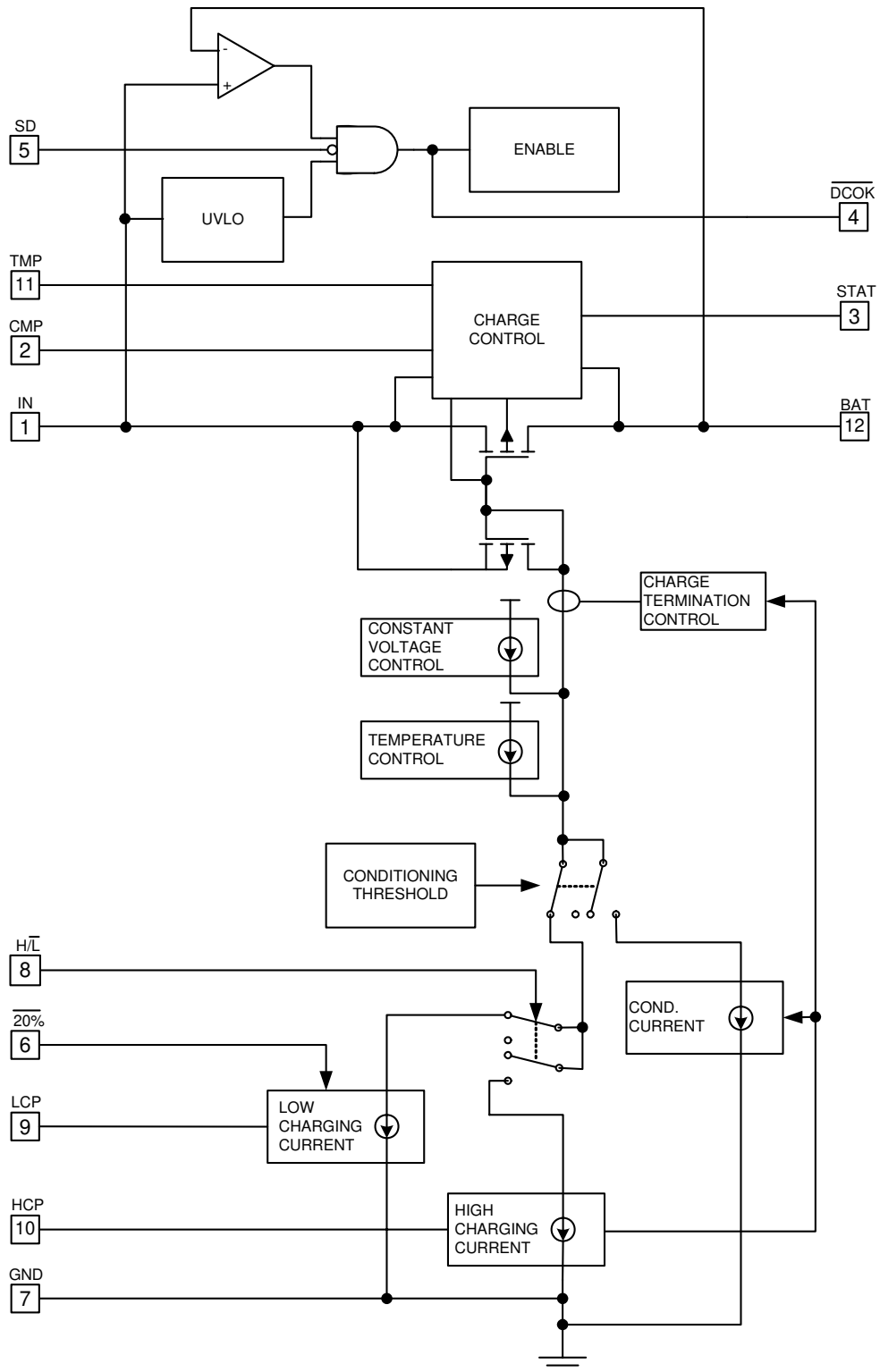

Figure 2 – Simplified Block Diagram

LX2208 EVAL

Connections. The LX2208 Evaluation Board has one power input and one power output connection.

FUNCTION	PIN NAME	VOLTAGE
Input Power	PWR	5V +/- 0.65V
Input RTN	GND	0V
Battery +	BAT+	0V to 4.3V
Battery -	RTN	0V

Jumpers. The LX2208 Evaluation Board has three two position jumper blocks. The jumper can be moved to select either a high logic level or low logic level. It is also possible to remove the jumper and apply a voltage directly to the center pin of the jumper block.

Hookup. The following is a demonstration scenario that can be used to evaluate the LX2208.

- 1) Apply the single cell Lithium Ion or Lithium polymer battery to the battery screw terminal block. Be sure to connect the positive terminal of the battery to the BAT+ terminal and the Negative terminal to the RTN terminal.
- 2) Move the SHUTDOWN jumper to the ON position, the USB jumper to the 500mA position and the POWER SELECT jumper to the WALL position.
- 3) Apply a +5V power source to the PWR terminal and the power supply return to the GND terminal.
- 4) The POWER ATTACHED and CHARGING LEDs should be lit when the battery is charging and the POWER ATTACHED and FULL LEDs should be lit when the battery is fully charged.
- 5) Monitor the charge current into the battery with a current probe.
- 6) Verify the charge current changes from approximately 2A to approximately 460mA when the POWER SELECT jumper is moved from the WALL to the USB position.
- 7) With the POWER SELECT jumper in the USB position, verify the charge current changes from approximately 460mA to approximately 92mA when the USB jumper is moved from the 500mA position to the 100mA position.
- 8) Verify that moving the SHUTDOWN battery to the OFF position extinguishes the LEDs and terminates the charge cycle.
- 9) The thermal lockout can be tested by momentarily applying a jumper between the RTC and RTN on the BAT TEMP jumper terminal. When the jumper is in place, the charging current will drop to zero, but the charge LED will remain illuminated.

LX2208 TYPICAL TEST HOOKUP

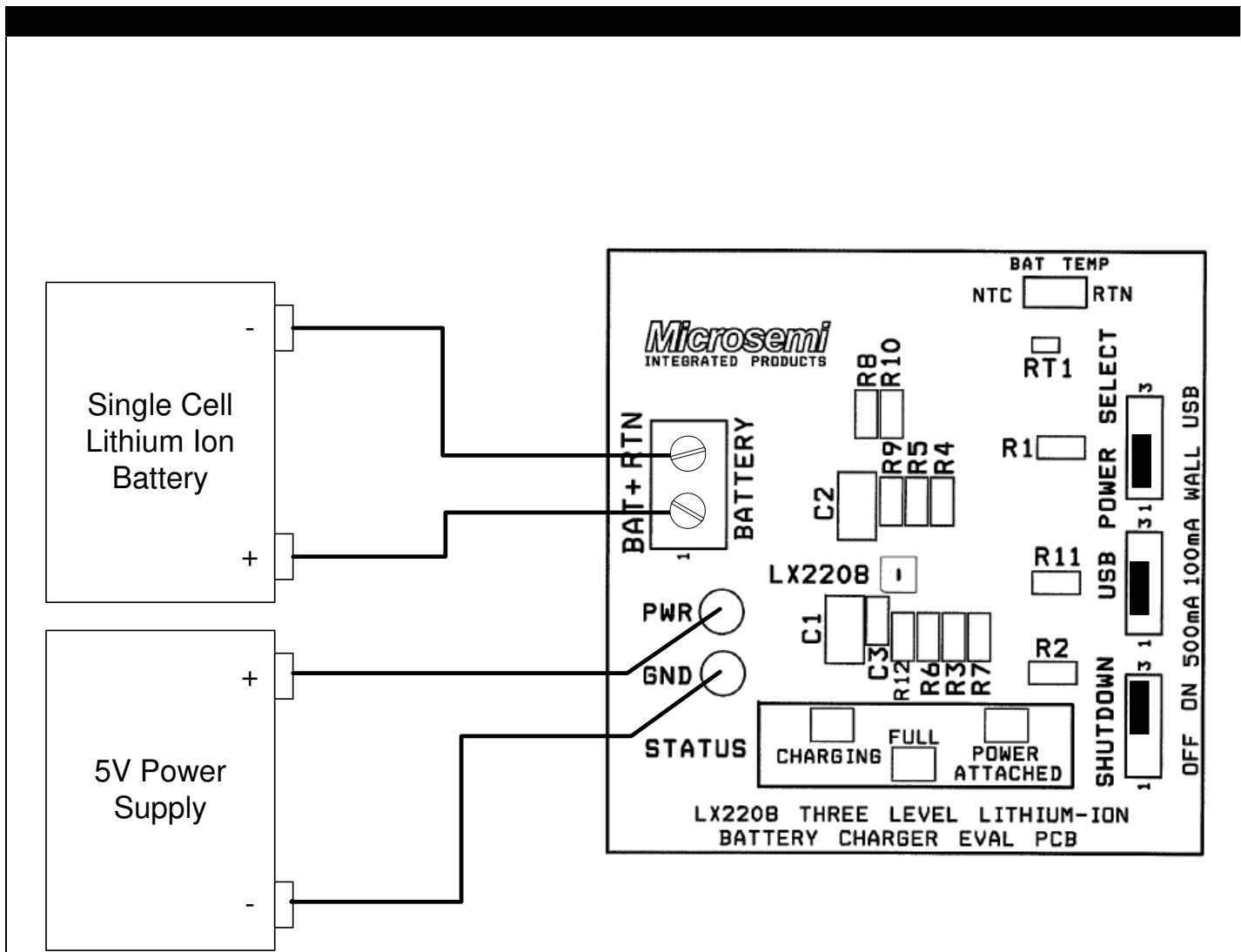

Figure 3 – LX2208 Typical Test Hookup

PCB LAYOUT RECOMMENDATIONS

It is recommended that C1 and C2 be located within 1cm of the LX2208. The CMP capacitor and resistor (C3 and R12) should be located close to the IN and CMP pins. Also the high impedance summing node connecting to the TMP pin should be kept relatively short to prevent the coupling of noise into this node. It is important that the LX2208 have a good thermal path to ambient to dissipate heat. The simplest way to do this is to heatsink the LX2208 bottom pad

directly to the ground plane by placing 4 or more vias in the ground pad directly under the LX2208 footprint.

LX2208 PRINTED CIRCUIT BOARD LAYOUT

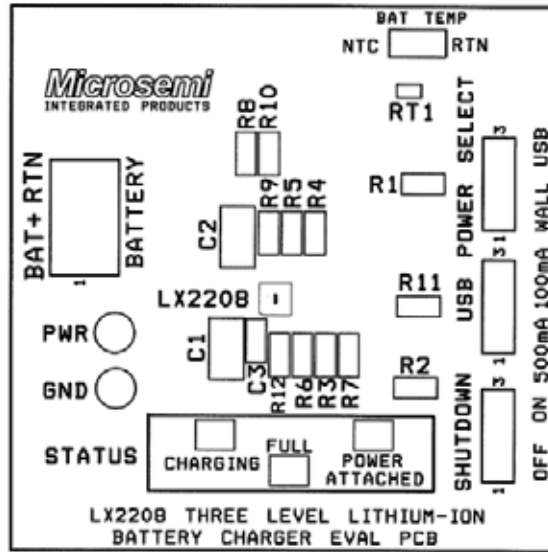

SILKSCREEN TOP RR

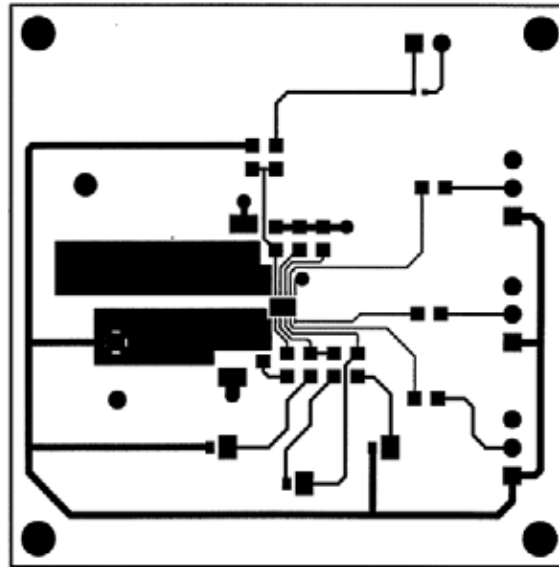

TOP LAYER RR

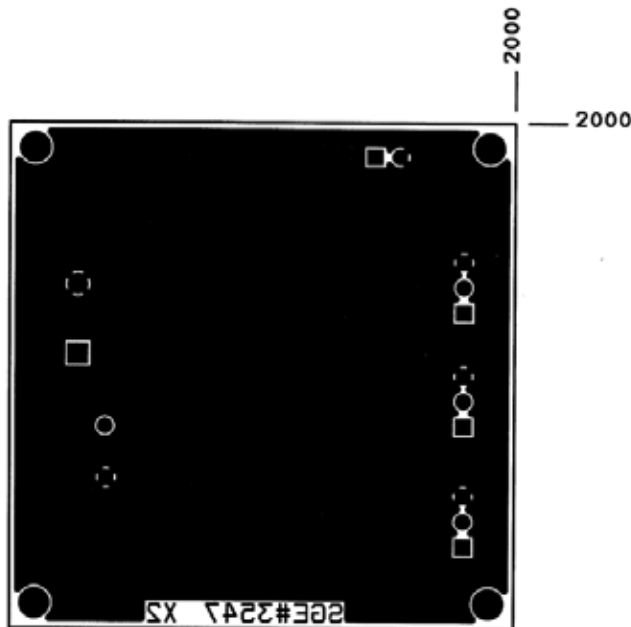

BOTTOM LAYER WR

Figure 3 – LX2208 Evaluation Board Layout

LX2208 EVALUATION BOARD BILL OF MATERIALS

MISCELLANEOUS COMPONENTS

Line Item	Part Description	Manufacturer & Part #	Case	Reference Designators	Qty
1	Microsemi IC – Tri Level Li-Ion Charger	MICROSEMI LX2208ILD	3x3 MLP	U1	1
2	LED - Amber	Panasonic LNJ414K8YRA	0603	CHARGING	1
3	LED - Red	Panasonic LNJ214K8ARA	0603	FULL	1
4	LED - Green	Panasonic LNJ314G8TRA	0603	POWER ATTACH	1
5	Thermistor – NTC, 100k	Vishay NTHS0402N01N1003J	0402	RT1	1
6	Terminal Block 2 position/ 7mm spacing	OST OST/2/7.0		BATTERY	1
7	Header 3 pin 0.100in spacing			I PGM, SHUTDN, PWR SEL	3
8	Header 2 pin 0.100in spacing			BAT TEMP	1
9	Header 1 pin			PWR, GND	2
10	Jumper, 2 Pos, 0.100 inch spacing			I PGM, SHUTDN	2
11	Printed Circuit Board	Microsemi SGE#3547 X1			1

CAPACITORS

Line Item	Part Description	Part Number	Case	Reference Designators	Qty
1	Capacitor, X5R, 10uF, 10V, 10%	Taiyo Yuden LMK316BJ106KD-T	1206	C1,2	2
2	Capacitor, X7R, 0.47uF, 16V, 20%	Taiyo Yuden EMK212BJ474KD-T	0805	C3	1

RESISTORS

Line Item	Part Description	Part Number	Case	Reference Designators	Qty
1	Resistor, 1.00K, 1%, 1/10W	Panasonic ERJ-6ENF1001V	0805	R1,2,11,12	4
2	Resistor, 2.49K, 1%, 1/10W	Panasonic ERJ-6ENF2491V	0805	R3,6,7	3
3	Resistor, 15.8K, 1%, 1/10W	Panasonic ERJ-6ENF1582V	0805	R4	1
4	Resistor, 3.57k, 1%, 1/10W	Panasonic ERJ-6ENF3571V	0805	R5	1
5	Resistor, 121K, 1%, 1/10W	Panasonic ERJ-6ENF1213V	0805	R8	1
6	Resistor, 24.9K, 1%, 1/10W	Panasonic ERJ-6ENF2492V	0805	R10	1