



Chipsmall Limited consists of a professional team with an average of over 10 year of expertise in the distribution of electronic components. Based in Hongkong, we have already established firm and mutual-benefit business relationships with customers from,Europe,America and south Asia,supplying obsolete and hard-to-find components to meet their specific needs.

With the principle of "Quality Parts,Customers Priority,Honest Operation,and Considerate Service",our business mainly focus on the distribution of electronic components. Line cards we deal with include Microchip,ALPS,ROHM,Xilinx,Pulse,ON,Everlight and Freescale. Main products comprise IC,Modules,Potentiometer,IC Socket,Relay,Connector.Our parts cover such applications as commercial,industrial, and automotives areas.

We are looking forward to setting up business relationship with you and hope to provide you with the best service and solution. Let us make a better world for our industry!



Contact us

Tel: +86-755-8981 8866 Fax: +86-755-8427 6832

Email & Skype: info@chipsmall.com Web: www.chipsmall.com

Address: A1208, Overseas Decoration Building, #122 Zhenhua RD., Futian, Shenzhen, China





DESCRIPTION	APPLICABLE DOCUMENTS	KEY FEATURES
<p>Microsemi's LX[®]23108LILQ is an 8-Port LED Driver used to drive LED strings. The LX23108LILQ has eight internal Current Limiters with high bandwidth PWM controls used to maintain the required LED current.</p> <p>The LX23108LILQ is controlled and driven by the LX[®]24132ILQ 32 port Display Backlight LED Controller (see Figure 4). Each LX24132ILQ can control up to four LX23108LILQs. The LX23108LILQ can drive currents of up to 100 mA @ 100% PWM, or 200 mA @ 50% PWM. The device is designed to operate with external sense resistors used for scaling the LEDs currents. Such configuration provides maximum flexibility for the system designers to change the LED current while maintaining high accuracy.</p> <p>A dedicated per channel PWM control signal coming from the LX24132ILQ enables/disables each of the eight channels. The LX23108LILQ is available in a 32 pin, 5 mm x 5 mm QFN package.</p>	<ul style="list-style-type: none"> ◆ LX24132ILQ / LX23108LILQ AN-182, Designing a Low Current LED BL Driver System, Catalogue Number 06-0077-080 ◆ LX24132ILQ Datasheet, 32 Port LED Driver Catalogue Number 06-0073-058 	<ul style="list-style-type: none"> ◆ Excellent thermal performance. ◆ High current accuracy: ± 2% overall chipset (LX24132ILQ and LX23108LILQ) precision current accuracy ◆ Driving capability (Constant – Current Sink) 0 mA to 100 mA @ 100% PWM, or 200 mA @ 50% PWM ◆ Per channel PWM signal ◆ Fault detection and protection: <ul style="list-style-type: none"> ▪ Open string ▪ Short LED ▪ Over-temperature protection per channel
<p>IMPORTANT: For the most current data, consult <i>Microsemi's</i> website: http://www.microsemi.com</p>		

PACKAGE ORDER INFO	
T _A (°C)	Plastic 5 x 5 mm QFN 32 pin
	RoHS compliant / Pb free
-40 to +85°C	LX23108LILQ
<p>Note: Available in Tape & Reel. Append the letters "TR" to the part number. (i.e. LX23108LILQ-TR)</p>	

Pin Configuration

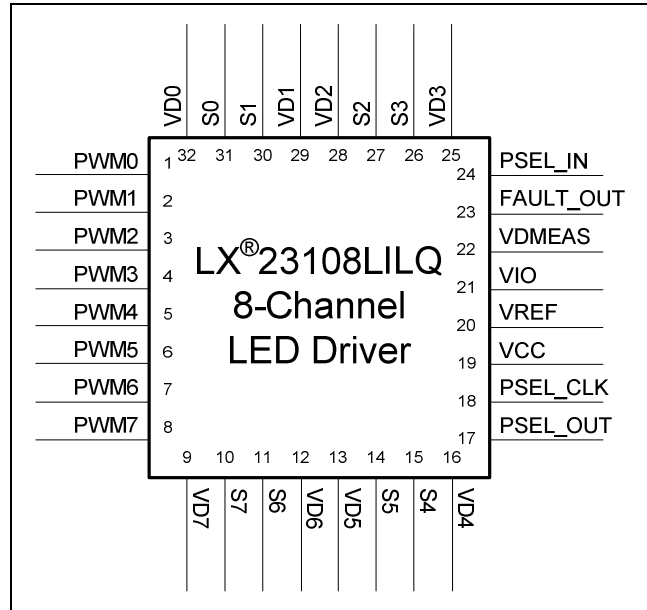

Figure 1: LX23108LILQ Pin Configuration

ABSOLUTE MAXIMUM RATINGS

Supply Input Voltage (V _{CC})	-0.5V to 5.5V
Supply I/O Voltage (V _{IO})	-0.5V to 5.5V
LED Control Pins	-0.3V to 72V
All Other Pins	-0.5V to V _{IO} +0.3 up to 5.5V
Operating Ambient Temperature Range	-40° to +85° C
Maximum Operating Junction Temperature	150°C
ESD Protection at all I/O pins	+/- 2KV HBM
Storage Temperature Range	-65°C to +150°C
Package Peak Temperature for Solder Reflow (40 seconds maximum exposure)	260°C (+0 / -5°C)

THERMAL DATA (POWER CONSUMPTION)

27.5° C/W thermal resistance-junction to ambient, according to the JESD51-7 (Contact factory for additional thermal performance data)
Junction Temperature Calculation: $T_J = T_A + (PD \times \theta_{ja})$.

ELECTRICAL CHARACTERISTICS

Unless otherwise specified, the following specifications apply to the operating ambient temperature: $-40^\circ\text{C} \leq T_{\text{AMB}} \leq 85^\circ\text{C}$ except where otherwise noted and the following test conditions exist: $V_{\text{CC}} = 5\text{V}$, $V_{\text{IO}} = 3.3\text{V}$.
Performance must be guaranteed for $0^\circ\text{C} \leq T_J \leq 110^\circ\text{C}$.



LX23108L- 8 Port LED Driver
Datasheet

Parameter	Symbol	Test Conditions / Comment	LX23108LILQ FET Array			Units
			Min.	Typ.	Max.	
Parameter						
Power Supply						
Input Voltage	V _{CC}		4.5	5	5.5	V
Input Voltage	V _{IO}	When communicating with 3.3v devices When communicating with 5v devices	3.0 4.5	3.3 5	3.6 5.5	V
Operating Current	I _{CC}	At V _{CC} = 5V		7		mA
	I _{IO}	At V _{IO} = 3.3V OR 5V		1		mA
Digital Interface						
Input Logic High Threshold	V _{IH}		2.2			V
Input Logic Low Threshold	V _{IL}				0.4	V
Output High Voltage	V _{OH}	I _{OH} = -1 mA	2.4			V
Output Low Voltage	V _{OL}	I _{OH} = 1 mA			0.4	V
LED Current Control						
Output Current Accuracy (See Note 1).		20 mA ≤ I _{OUT} ≤ 100 mA @ 100% duty cycle (T _{AMB} = 25° C)		±0.57	±0.74	%
		20 mA ≤ I _{OUT} ≤ 100 mA @ 100% duty cycle (-40°C ≤ T _{AMB} ≤ 85° C)			±1	%
		I _{OUT} = 200 mA @ 50% duty cycle, V _{SENSE} = 350 mV (R _S = 1.75 Ω).			±0.72	%
Output Current Matching (See Note 1).		20 mA ≤ I _{OUT} ≤ 100 mA @ 100% duty cycle, (T _{AMB} = 25° C)			±0.4	%
		20 mA ≤ I _{OUT} ≤ 100 mA @ 100% duty cycle (-40°C ≤ T _{AMB} ≤ 85° C)			±0.5	%
		I _{OUT} = 200 mA @ 50% duty cycle, V _{SENSE} = 350 mV (R _S = 1.75 Ω).			±0.44	%
V _{REF} Range			0		2.5	V
Sense Voltage Range (pins S0 to S7)	V _{SENSE}		0		357	mV
LED Switching FET Resistance	R _{DS-ON}			2.6		Ω
Minimum Drain-Source Voltage	V _{DS-MIN}	@ 50 mA LED current		150		mV
		@ 100 mA LED current		280		mV
Channel Leakage Current (leak)		While channel is off and V _{LED} = 65V			1	μA
Channel Turn-on Time (fall-time) (See Note 2)		@ R _L = 60Ω, C _L = 33pF, V _{LED} = 5V	0.56	1	1.9	μS
Protections						

Parameter	Symbol	Test Conditions / Comment	LX23108LILQ FET Array			Units
			Min.	Typ.	Max.	
Over Temperature Detection	Maximum Temp.	Per channel thermal sensor located on the main LED's switching FET; it shuts off if the junction temperature exceeds the maximum.	150	180	210	°C
LED Short Circuit Detection		At T _{AMB} = 25° C and V _{CC} = 5V. It shuts a channel off if the Vd voltage exceeds this level.	8	8.8	10	V

Note 1: The Absolute Current Accuracy ΔI is calculated as follows:

$$\Delta I [\%] = 100 \cdot \frac{I_{OUT_N} - I_{SET}}{I_{SET}} \%$$

I_{OUT_N} is the output current of any "N" channel within the system.

I_{SET} is the current set by the user and given by:

$$I_{SET} = \frac{V_{REF}}{2.5V} I_{MAX}$$

I_{MAX} is the maximum LED current

The Current Matching ΔI_{MATCH} is calculated as follows:

$$\Delta I_{MATCH} [\%] = 100 \cdot \frac{I_{OUT_K} - I_{AVG}}{I_{AVG}} \%$$

I_{OUT_K} is the output current of any "K" channel within the same LX23108LILQ port LED driver.

I_{AVG} is the average current of all array channels calculated as follows:

$$I_{AVG} = \frac{\sum_K I_{OUT_K}}{K}$$

Note 2: Figure 2 shows the test circuit for rise/ fall time measurements.

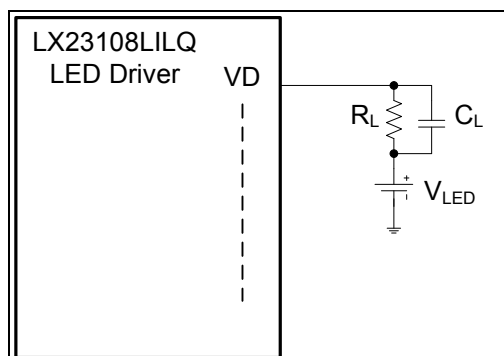

Figure 2: Test Circuit for Channel Rise/Fall Time Measurements



Functional Pin Description

Name	Pin #	Description
PWM0-7	1 - 8	Logic Input signals, per channel ON/OFF control. When asserted "0" at the PWM, the LED string is disabled (OFF).
S0-7	31, 30, 27, 26, 15, 14, 11, 10	Current sense pins connected to an external resistor. The signal from each pin is fed to the input of a dedicated regulation amplifier, maintaining the required LED current, set by the reference voltage.
VD0-7	32, 29, 28, 25, 16, 13, 12, 9	Output pins connected to the LED string loads. These high voltage outputs are switched ON/OFF according to the PWM frequency and duty cycle control (PWM input signals).
PSEL_IN	24	Serial data input pin. The data from the PSEL_IN is clocked into a shift register at the rising edge of the PSEL_CLK signal. The shifted pulse is used to select each drain voltage and thermal sensing signals, which are sequentially sent to the VDMEAS and FAULT_OUT pins for monitoring.
PSEL_OUT	17	Serial data output pin. The data from the LX23108LILQ's internal shift register is clocked out at the rising edge of the PSEL_CLK signal. This serial PSEL_OUT signal is cascaded to the PSEL_IN input of the next LX23108LILQ device. This allows the sequential selection of all LX23108LILQs channels linked to a LX24132ILQ (see VDMEAS and FAULT_OUT signals description below). Through this mechanism, up to 32 channels can be controlled for VDMEAS and FAULT_OUT monitoring.
PSEL_CLK	18	Clock signal used for the PSEL_IN / PSEL_OUT operation. Each single clock shifts the internal register data by one bit, allowing monitoring of the next channel.
VDMEAS	22	Drain voltage output signal. Each channel's drain voltage is multiplexed into this pin when selected by the internal shift register.
FAULT_OUT	23	Open drain output signal indicates fault. All the channel's latched thermal sensors and LED short circuit detectors outputs are multiplexed into this pin when selected by the internal shift register.
VREF	20	Analog input signal. This DC voltage is driven by the LX24132ILQ 32 Port Display Backlight LED Controller and used to set all LED strings' current level.
VCC	19	Supply voltage for the internal circuitry. A low ESR bypass capacitor (not less than 1 uF) should be placed as close as possible to this pin using low impedance traces to GND so as to filter the voltage.
VIO	21	I/O Supply voltage.

Package Information

LQ

32-Pin 5x5 mm QFN

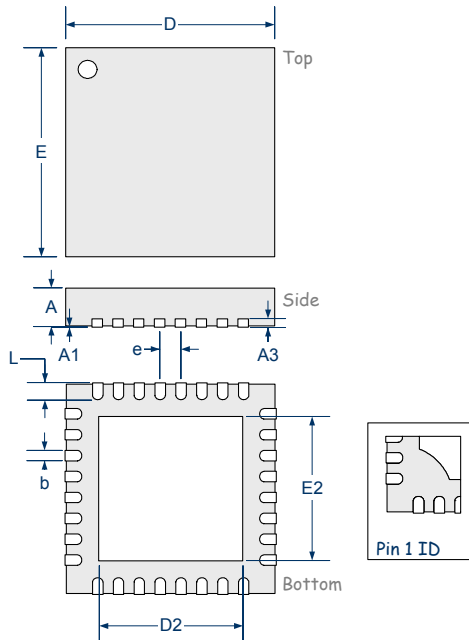

DIM	MILLIMETERS		INCHES	
	MIN	MAX	MIN	MAX
A	0.80	1.00	0.031	0.039
A1	0	0.05	0	0.002
A3	0.20 REF		0.008 REF	
b	0.18	0.30	0.007	0.012
D	5.00 BSC		0.197 BSC	
D2	3.30	3.60	0.130	0.142
E	5.00 BSC		0.197 BSC	
E2	3.30	3.60	0.130	0.142
e	0.50 BSC		0.02 BSC	
L	0.30	0.50	0.012	0.020

Note:

Dimensions do not include protrusions; these do not exceed 0.155 mm (.006") on any side. Lead dimension shall not include solder coverage.

Functional Description

The following sections provide detailed information about the chip, its functions and applications.

LX23108LILQ Block Diagram

The LX23108LILQ has eight current limiters controlled by a dedicated reference voltage and by eight independent PWM control signals (received from the LX24132ILQ). The LX23108LILQ is designed to operate with current scaling external sense resistors connected to its S0 - S7 pins (refer to Figure 3).

Each current limiter employs three components;

- Operational amplifier
- MOSFET
- External sense resistor

These components are utilized to regulate the LED string current to achieve the desired value.

Channels drain voltage measurements are performed at each string's "on" time, in accordance with the PSEL_CLK and PSEL_IN commands received from the LX24132ILQ 32 Port Display Backlight LED Controller. Each output MOSFET has a thermal sensor which causes it to switch off when its temperature exceeds a predetermined value.

At the same time, the channels output voltages are successively sensed for any possible LED short circuit.

Over-Temperature/LED Short-Circuit Events; Latch and Select Operation Description

Each output MOSFET is thermally protected by a temperature sensor that forces its gate to 'Low' in over-heating scenarios (see TP block in Figure 3). Hence, the MOSFET is switched off, regardless of the PWM<n> digital command.

The thermal status of each channel is read by the LX24132ILQ sequentially by utilizing a sampling pulse that clocks the thermal flip-flops at the falling edge. If no thermal event occurs, the flip flop's output is maintained 'Low', as well as its associated AND gate.

When a thermal event occurs the following takes place:

- The set pin of the thermal flip flop is grounded.
- The Q output is asynchronously forced to a 'High'.
- The output of the AND gate is maintained at 'High' unless a sampling pulse is issued.

- However, while Q is at 'High', the amplifier is disabled by an additional AND gate. The sequential sampling also activates an over-voltage sensing mechanism formed by OV switches, a resistor divider and a voltage

comparator. Such comparator is common to all eight ports and reports LED shorts through a general chip OR gate.

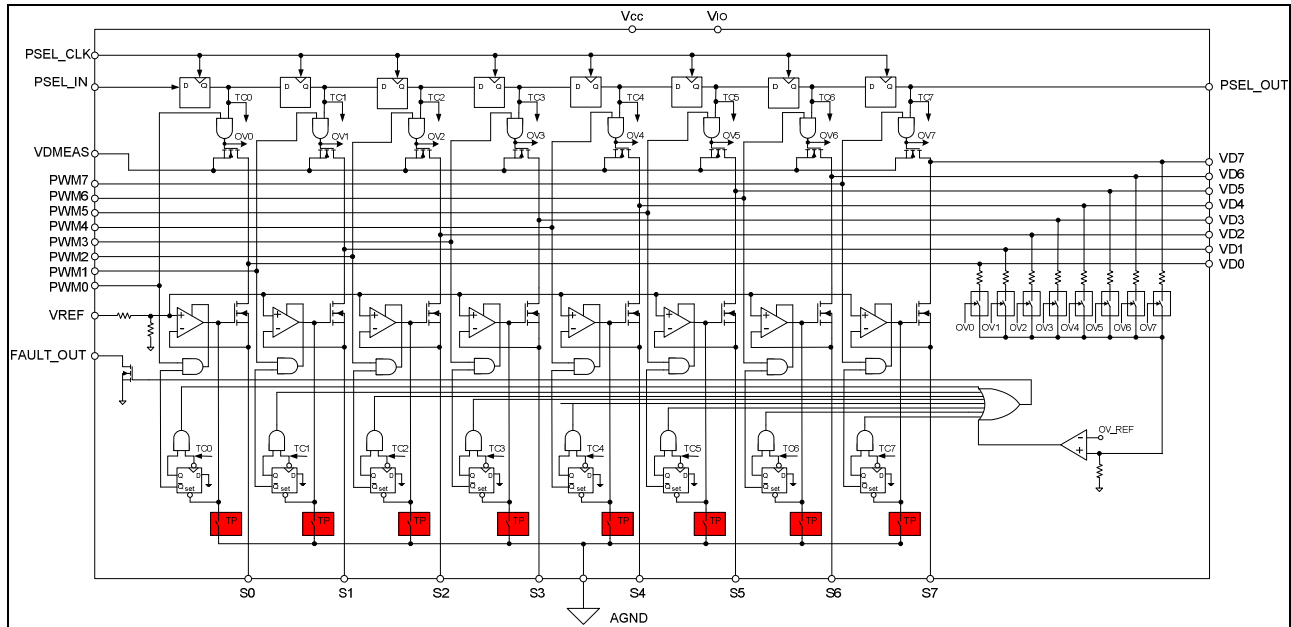

Figure 3: LX23108LILQ Block Diagram



Current Sense Resistor Selection

The value of the external sense resistors is determined as shown below:

$$R_{SENSE} = \frac{V_{REF_MAX}}{7 \cdot I_{MAX}} - R_{IC} - R_{PCB}$$

V_{REF_MAX} is equal to 2.5V; it is the maximum reference voltage.

I_{MAX} is the maximum LED current.

R_{IC} and R_{PCB} are internal IC and PCB resistances, respectively. Typically, R_{IC} is 85 mΩ and R_{PCB} is 15 mΩ.

Power Dissipation Calculation

The power dissipated by the LX23108LILQ 8-port LED driver is calculated as follows:

$$P_D = V_{CC}I_{CC} + V_{IO}I_{IO} + I_{OUT} \cdot \sum_K V_{DS_K} \cdot D_K$$

I_{OUT} is the output current.

V_{DS_K} and D_K are the drain-source voltage and PWM duty-cycle at channel "K".

Drain Measurements and Select Operation Description

A logic circuitry within the LX23108LILQ enables the LX24312ILQ to sequentially measure all the array drain voltages and stores the results in internal registers.

The measurements are performed when appropriate commands (determined by the PSEL_IN and PSEL_CLK) are received from the LX24312ILQ at each string's "on" time.

The System Controller uses this information in conjunction with its algorithms to calculate the power dissipation and control the power supply voltage (see Figure 4).

Fault Detection and Protection

The LX23108LILQ, in conjunction with the LX24132ILQ, has fault detection and protection feature dedicated for an open LED string, short LED and over-temperature (see Figure 4). The open string and short LED faults are detected one by one in such a way that if a fault is detected at a specific stage, it can be shut down individually without affecting the operation of the other LEDs.

The over-temperature protection circuits monitor the die temperature and shut down the relevant channel when temperature reaches a trigger point (See Figure 3 and Figure 4). Such channel returns to normal operation when the temperature drops below the recovery threshold.

Typical Application

As shown in Figure 4, 32 LED strings are supported by a single LX24132ILQ 32 Port Display Backlight LED Controller and four LX23108LILQs arrays (eight ports each).

Typical applications include:

- LCD display back-lighting
- LED signboards
- LED displays

The System Controller (LED BL FPGA) controls the general modes and sets the parameters for the operation of the LX24132ILQ devices used in the system. The LX24132ILQ sequentially measures the voltages of all LX23108LILQ 8-port LED driver's channels.

The System Controller performs various calculations based on each LX24132ILQ measurement. Measurements and status information are available in registers within the LX24132ILQ digital block that are accessed through a designated SPI communication bus (see Figure 4).

Therefore, bi-directional information between the system Controller and the LX24132ILQ flows via the SPI communication protocol.

The LX24132ILQ controls the BackLight LED currents by driving the LX23108LILQ 8-port LED drivers with an accurate voltage reference. Hence, the LX23108LILQs generates accurate currents for LED strings, up to eight strings per array chip.

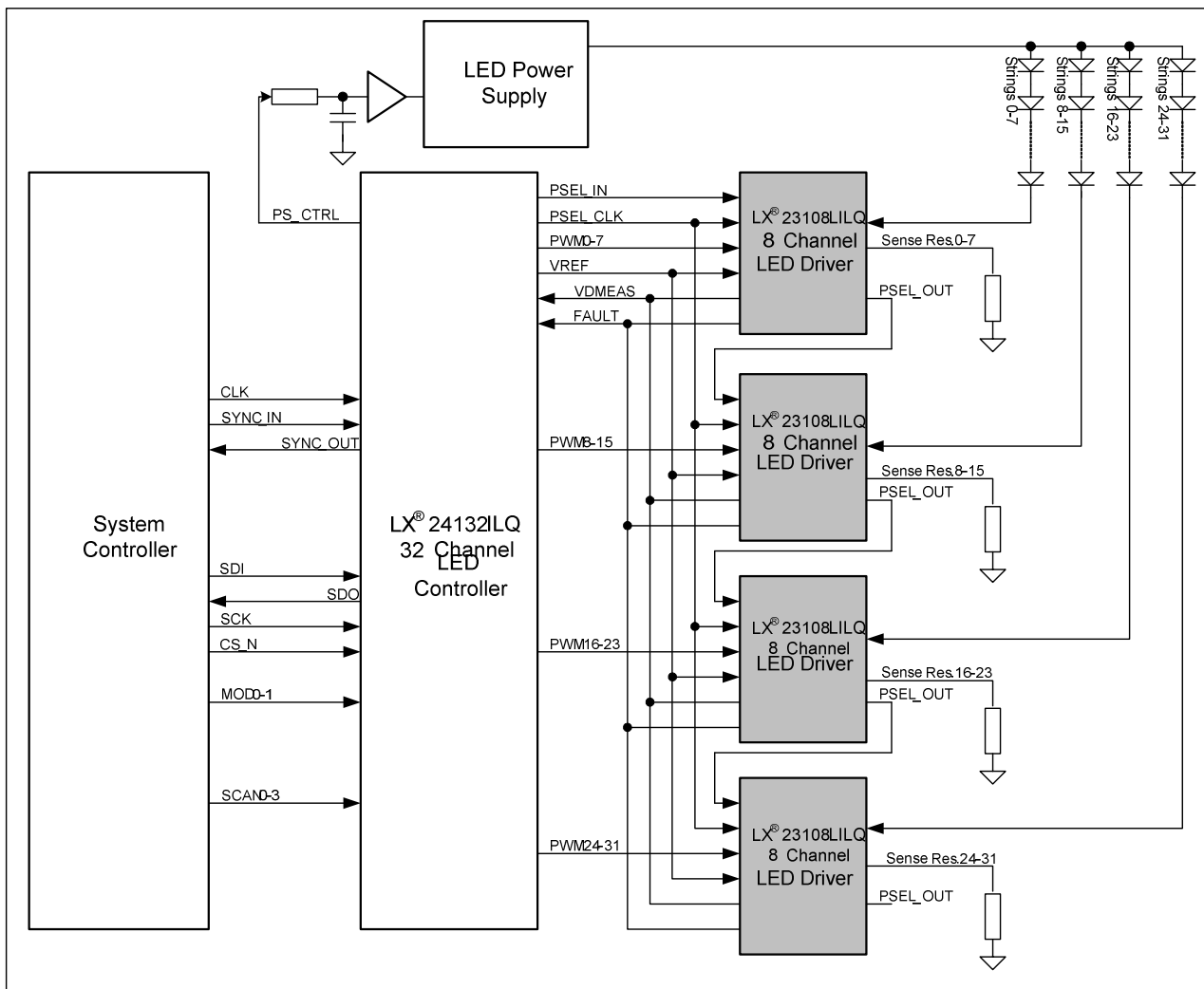

Figure 4: Low Voltage LED Controller and 8 Channel LED Driver



LX23108L- 8 Port LED Driver Datasheet

The information contained in the document is PROPRIETARY AND CONFIDENTIAL information of Microsemi and cannot be copied, published, uploaded, posted, transmitted, distributed or disclosed or used without the express duly signed written consent of Microsemi...

Microsemi reserves the right to change the configuration, functionality and performance of its products at anytime without any notice. This product has been subject to limited testing and should not be used in conjunction with life-support or other mission-critical equipment or applications.

Revision History

Table with 3 columns: Revision Level / Date, Para. Affected, Description. Rows include: 0.1/11 September. 08 - Initial Release; 0.2/27 November. 08 - Whole document modified; 0.3/27 February. 09 - Replacing cat. Numbers from PD24108L to LX24108L and PD24132 to LX24132ILQ; 0.4/ 27 March, 09 - Updating ordering and package information; 1.0/ 27 April, 09 - Parameters update; 1.1/ 28 May, 09 - Description update; 1.2 / 3-Nov-09; 1.2 / 27-Jul-10 - Changing catalog numbers metrology; 1.0A /12 Oct 10 - Changing Ver only

© 2009 Microsemi Corp. All rights reserved.

For support contact: sales_AMSG@microsemi.com

Visit our web site at: www.microsemi.com

Cat. No. DS_LX23108L