



Chipsmall Limited consists of a professional team with an average of over 10 year of expertise in the distribution of electronic components. Based in Hongkong, we have already established firm and mutual-benefit business relationships with customers from,Europe,America and south Asia,supplying obsolete and hard-to-find components to meet their specific needs.

With the principle of “Quality Parts,Customers Priority,Honest Operation,and Considerate Service”,our business mainly focus on the distribution of electronic components. Line cards we deal with include Microchip,ALPS,ROHM,Xilinx,Pulse,ON,Everlight and Freescale. Main products comprise IC,Modules,Potentiometer,IC Socket,Relay,Connector.Our parts cover such applications as commercial,industrial, and automotives areas.

We are looking forward to setting up business relationship with you and hope to provide you with the best service and solution. Let us make a better world for our industry!



## Contact us

Tel: +86-755-8981 8866 Fax: +86-755-8427 6832

Email & Skype: info@chipsmall.com Web: www.chipsmall.com

Address: A1208, Overseas Decoration Building, #122 Zhenhua RD., Futian, Shenzhen, China



# High Performance CCFL Controller



## DESCRIPTION

**CCFL Controller for Next Generation of 37 inch and Smaller LCD TVs, Monitors or All-in-One PCs with Ultra-Realistic Display Quality and Performance Integrates JIN's PureBLACK™ Megacontrast Dimming**

The LX6523A is a high performance CCFL controller optimized for small or medium size LCD-TV and other multi-lamp LCD display systems. It enables cost competitive solutions for off-PFC HV-LIPS inverter applications. The controller provides a pair of push-pull PWM drive signals. The output drivers can drive a push-pull, half bridge, or full bridge CCFL inverter configuration with the addition of simple external circuitry.

An on-chip regulator supplies both the operating voltage for the output gate drive and bias to the internal control circuitry. This allows a direct connection of the controller to the system supply extending the voltage up to 27V without external regulators. The lamp current regulation circuit comprises a simple and robust control loop design with good regulation accuracy and dynamic response at transient conditions. A soft start feature provides more reliable lamp strike and allows effective control of the possible inverter start up surge current and lamp current/voltage overshoot.

The LX6523A integrates JIN's PureBLACK™ megacontrast digital burst dimming functionality to provide true black mega contrast capabilities for CCFL based displays. In addition, reliable fault detection and protection functions are facilitated including open lamp, over voltage, short circuit, and over current protection. Furthermore, programmable striking frequency, programmable strike and protection timing, and fault indication are all built-in with the very compact chip design. The device is available in a 14 lead narrow body SOIC surface mount package with an industrial temperature grade rating.

## Key Features

## Benefits

### 400V Off-PFC HV-LIPS Support

- > Half-bridge or Full-Bridge drive support for inverters

### Optimal System Cost and Increased Efficiency

- > Reduced number of power stages increase efficiency at a reduced overall system BOM – easier regulatory agency compliance

### Integrated JIN's PureBLACK™ Mega Dimming

- > Supports BURST PWM dimming for 'true zero' percent duty cycle operation

### Enhanced Image Quality and more Realistic Video

- > Superior black levels for increased dynamic contrast ratio
- > Great shadow detail for a more enjoyable viewing experience

### Comprehensive Brightness Control Modes

- > Analog only ⇔ adjust lamp current only
- > Analog BURST Dimming ⇔ analog voltage to BURST PWM
- > Digital BURST Dimming ⇔ Direct PWM BURST input

### Increased Flexibility and Performance

- > Wide dimming range and multiple architecture support
- > Ease of implementation
- > Reduced cost with reduction of external components

### Multiple Drive Topologies Supported

- > Push-Pull, Half-bridge, and Full-bridge
- > 600mA sourcing or sinking gate drivers

### Ease of Use and Flexibility

- > One device supports multiple inverter architectures and applications
- > Reduces cost by eliminating need for high current external buffer

### Protection, Lamp Strike, Detection, and Operation

- > OLP, OVP (regulation/protection), OIP and Short Circuit
- > Programmable STRIKE and Fault time (run mode)
- > Programmable STRIKE frequency

### Reliability, Flexibility, Ease of Use, and Reduced Cost

- > User configurable, supports multiple panel types and customer need
- > Enhanced operation at very low duty cycles to avoid false open lamp protection while detecting true open lamp detection

## APPLICATIONS

- > Small to medium size LCD televisions
- > 19" to 30" Multi-lamp LCD monitors
- > High end graphics and medical imaging monitors requiring highest image quality
- > All-in-One PCs
- > CCFL, EEFL, FFL Backlight systems

### Additional Features

- > 6V to 27V power rail operation
  - 36V absolute maximum
- > On chip voltage regulator
  - With UVLO protection, POR
- > Soft Start Control
- > Highly accurate lamp operation
  - Current control  $\Rightarrow$  +/- 2%
  - Frequency set  $\Rightarrow$  +/- 3%
- > Programmable STRIKE time and STRIKE frequency
- > Programmable FAULT time
- > Programmable BURST dimming frequency
- > ENABLE control signal
- > Supports 2:1 Strike/Run frequency ratios (typical)
- > JIN Balancer optimized to support 'true' zero BURST duty cycle dimming
- > Industrial Temperature Grade
  - -40°C to +85°C
- > 14 lead, narrow body, SOIC

### Simplified Block Diagram

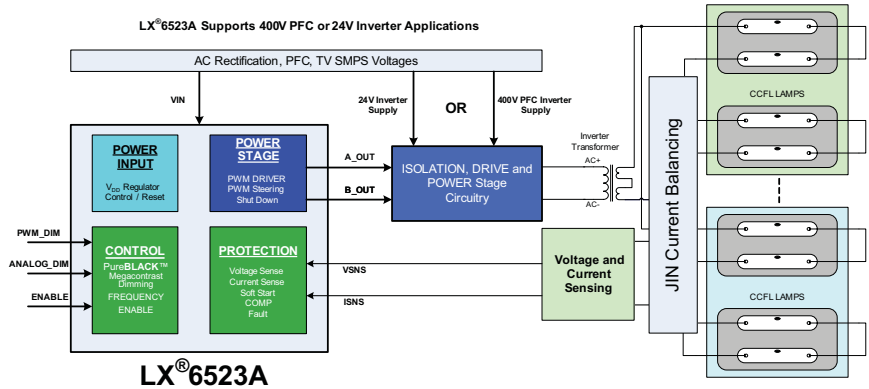

### HV-LIPS Overall System Diagram

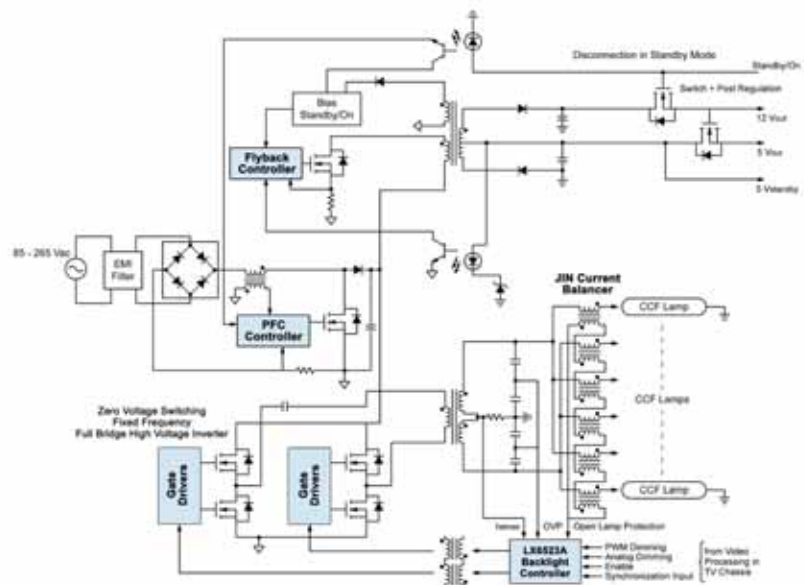

### Ordering Information

LX6523AID	SOIC, 14 lead, Narrow Body, RoHS compliant, Pb-free, Industrial Temperature, Tubes	$\theta_{JA} = 86^{\circ}\text{C/W}$
LX6523AID - TR	SOIC, 14 lead, Narrow Body, RoHS compliant, Pb-free, Industrial Temperature, Tape and Reel $\Rightarrow$ 2500 pcs/reel	$\theta_{JA} = 86^{\circ}\text{C/W}$

**Technical Support Information:** For LX6503A / LX6523A and other CCFL or Display family of products, please contact your local Microsemi Field Applications Engineer.

For more information about Microsemi products and the name of a local representative, distributor or sales person, please visit [www.microsemi.com](http://www.microsemi.com) or contact us at +1 (714) 898-8121 or +1 (949) 221-7100.

