



Chipsmall Limited consists of a professional team with an average of over 10 year of expertise in the distribution of electronic components. Based in Hongkong, we have already established firm and mutual-benefit business relationships with customers from,Europe,America and south Asia,supplying obsolete and hard-to-find components to meet their specific needs.

With the principle of “Quality Parts,Customers Priority,Honest Operation,and Considerate Service”,our business mainly focus on the distribution of electronic components. Line cards we deal with include Microchip,ALPS,ROHM,Xilinx,Pulse,ON,Everlight and Freescale. Main products comprise IC,Modules,Potentiometer,IC Socket,Relay,Connector.Our parts cover such applications as commercial,industrial, and automotives areas.

We are looking forward to setting up business relationship with you and hope to provide you with the best service and solution. Let us make a better world for our industry!



Contact us

Tel: +86-755-8981 8866 Fax: +86-755-8427 6832

Email & Skype: info@chipsmall.com Web: www.chipsmall.com

Address: A1208, Overseas Decoration Building, #122 Zhenhua RD., Futian, Shenzhen, China



DESCRIPTION

The LX8211 fixed/adjustable voltage linear regulators combines low dropout, high accuracy, ultra-low ground current and fast response in a very small footprint.

Using the Enable pin the regulators is switched on with TTL logic levels, which is especially useful for battery-operated equipment. Other features include independent Thermal and Short Circuit Current protection. The regulator is stable with a low value ceramic output capacitors.

For ultra low noise operation a Bypass pin is brought out to connect an optional capacitor. Significant performance improvements over Bipolar technology are achieved designing in CMOS: increased regulator efficiency by minimizing operating ground current (typ<140uA) and it is nearly eliminated (typ<1uA) in shutdown. The PMOS output transistor allows for ultra low dropout typically less than 300mV at 100mA.

IMPORTANT: For the most current data, consult MICROSEMI's website: <http://www.microsemi.com>

KEY FEATURES

- Dropout Voltage typically 175mV @ 100mA
- Ultra low shutdown Current typically less than 1uA
- High Output accuracy trimmed to 0.25%
- Standard pinout in SOT-23-5
- Noise Bypass feature available
- Current and Over Temperature protection
- Stable with low cost ceramic output capacitor

APPLICATIONS

- Battery Operated Systems
- Laptop, Notebook and PDA's
- Cellular Telephones/pagers
- Hand-Held Instruments
- Linear post regulators for SMPS

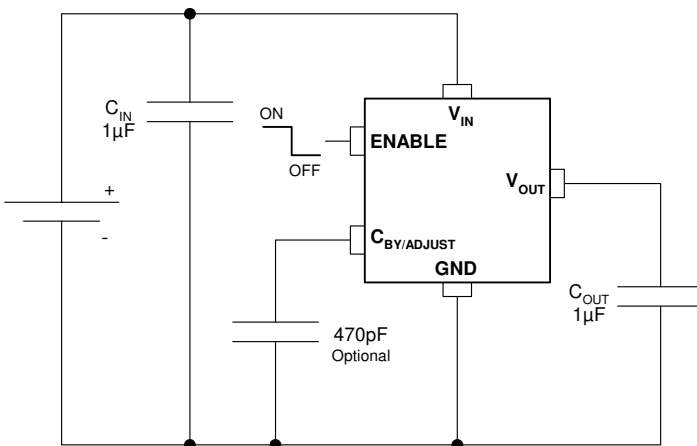
PRODUCT HIGHLIGHT

PACKAGE ORDER INFO

T _J (°C)	OUTPUT VOLTAGE	SE	Plastic SOT-23 5-PIN	PACKAGE MARKING
		RoHS Compliant / Pb-free Transition DC: 0503		
-40 to 125	Adjustable		LX8211-00ISE	82A1
-40 to 125	2.5V		LX8211-25ISE	82B1
-40 to 125	2.7V		LX8211-27ISE	82D1
-40 to 125	2.8V		LX8211-28ISE	82E1
-40 to 125	3.0V		LX8211-30ISE	82G1
-40 to 125	3.3V		LX8211-33ISE	82K1

Note: Available in Tape & Reel. Append the letters "TR" to the part number. (i.e. LX8211-25ISE-TR)

ABSOLUTE MAXIMUM RATINGS

Input Voltage (V_{IN})	-0.3V to +7V
Enable Input	-0.3V to $V_{IN}+3V$
Output Current (I_{OUT})	150mA
Operating Temperature Range	-40 to +125 °C
Maximum Junction Temperature (T_J)	150 °C
RoHS Compliant / Pb-free Peak Package Solder	
Reflow Temperature (40 second max. exposure)	260°C (+0, -5)

Note: Exceeding these ratings could cause damage to the device. All voltages are with respect to Ground. Currents are positive into, negative out of specified terminal.

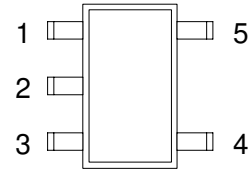
PACKAGE PIN OUT

SE PACKAGE
(Top View)

RoHS / Pb-free 100% Matte Tin Pin Finish

THERMAL DATA
SE 5-PIN SOT-23 PACKAGE
Thermal Resistance – Junction to Ambient, θ_{JA}

▪ Two – Layer Board	220°C/W
▪ Four – Layer Board	220°C/W

Junction Temperature Calculation: $T_J = T_A + (P_D \times \theta_{JA})$.

The θ_{JA} numbers are guidelines for the thermal performance of the device/pc-board system. All of the above assume no ambient airflow.

FUNCTIONAL PIN DESCRIPTION

PIN NAME	PIN NUMBER	DESCRIPTION
VIN	1	Unregulated input supply voltage
GND	2	Ground Pin
ENABLE	3	Enable Control Input, Enable High
CBY/ADJUST	4	Reference bypass input. Adding an additional external capacitor reduces output noise . Or adjust control input for LX8211-00.
VOUT	5	Regulated output voltage. Regulator stability is achieved with external capacitor of 1uF

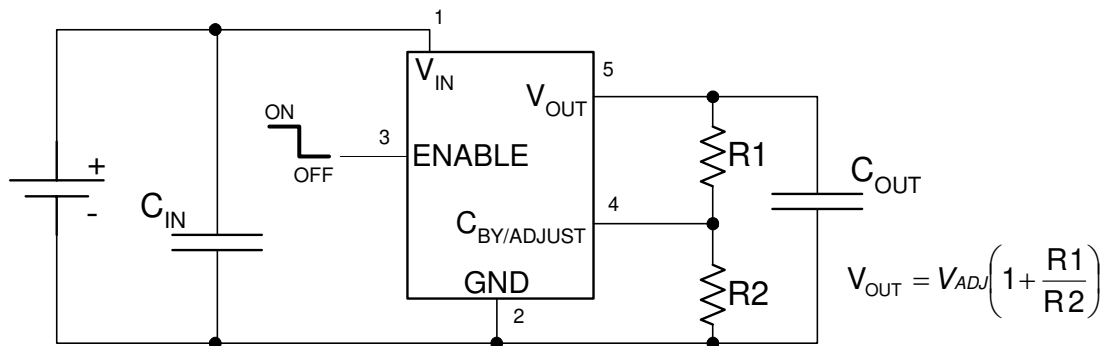
APPLICATION

Figure 1 – Output Voltage Set Externally

RECOMMENDED OPERATING CONDITIONS

Parameter	Symbol	LX8211-xx			Units
		Min	Typ	Max	
Input Operating Voltage Range (Note 1)	V _{IN}	2.5		6	V
Enable Input Voltage Range	ENABLE	0		V _{IN} + .3V	
Continuous Output Current Range	I _{OUT}	.1		150	mA
Input Capacitor (V _{IN} to GND)	C _{IN}	1.0	1.0*		μF
Output Capacitor (V _{OUT} to GND)	C _{OUT}	1.0	2.2*		μF

Note 1: The minimum V_{IN} has to meet two conditions V_{IN} ≥ 2.5V and V_{IN} ≥ V_{OUT} + V_{DROPOUT}.

* Size your output capacitor to meet the transient loading requirement. If you have a very dynamic load, a lower ESR and larger value capacitor will improve the response to these load steps.

ELECTRICAL CHARACTERISTICS

Unless otherwise specified, the following specifications apply over the operating ambient temperature -40°C ≤ T_A ≤ 125°C except where otherwise noted. Test conditions: V_{IN} = V_{OUT} + 0.5V; I_{OUT} = 10mA; C_{IN} = 1μF; C_{OUT} = 1μF; T_J = T_A using low duty cycle pulse testing methods.

Parameter	Symbol	Test Conditions	LX8211-XX			Units
			Min	Typ	Max	
Output Voltage (-25, -27, -28, -30, -33)	V _O	T _J = 25°C	-1		1	%V _{NOM}
		I _{OUT} = 0mA to 150mA, V _{IN} = V _{OUT} + .5V to 6V	-2.5		2.5	%V _{NOM}
Adjust Reference Voltage (-00)	V _{ADJ}	T _J = 25°C	1.163	1.175	1.187	V
		I _{OUT} = 0mA to 150mA, V _{IN} = 2.85V to 6V	1.14		1.20	
Line Regulation $\left(\frac{\Delta V_O}{\Delta V_{IN}}\right)$	V _{RV}	V _{IN} : V _{OUT} + 0.5 TO 6 VOLTS, I _{OUT} = 0.1mA		0.04	0.15	%/V
Load Regulation $\left(\frac{\Delta V_O}{\Delta I_O}\right)$	V _{RI}	T _J = 25°C, I _{OUT} : 0.5 TO 150mA		0.5	1.0	%V _{NOM}
		I _{OUT} : 0.5 TO 150mA			1.5	%V _{NOM}
Dropout Voltage (V _{IN} - V _O) (Note2)	V _{DO}	I _{LOAD} = 1mA, ΔV _O = -1%			0.05	V
		I _{LOAD} = 50mA, ΔV _O = -1%		0.1	0.175	V
		I _{LOAD} = 100mA, ΔV _O = -1%		0.175	0.3	V
		I _{LOAD} = 150mA, ΔV _O = -1%		0.25	0.4	V
Ground Pin Current	I _{IGND}	Enable = Hi		140	220	μA
	I _{STBY}	Enable = Low			1	μA
Adjust Input Bias Current	I _{ADJ}	V _{ADJ} = 1.175V			100	nA
Enable Pin Current	I _{EN}	V _{EN} = V _{IN}			100	nA
Enable Threshold	V _{IH}		2.0			V
	V _{IL}				0.4	V
Short Circuit Current Limit	I _{OUTSC}	V _{OUT} = 0V		400		mA
Power Supply Rejection Ratio	PSRR	T _J = 25°C, f = 120Hz		50		dB
Output Noise	e _N	T _J = 25°C, C _{OUT} = 10μF, C _{BYPASS} = 470 pF		50		μV
Thermal Shutdown Temperature	T _{SD}			170		°C

Note 2: Dropout voltage is defined as the input to output differential at which the output voltage drops 1% below the nominal value.

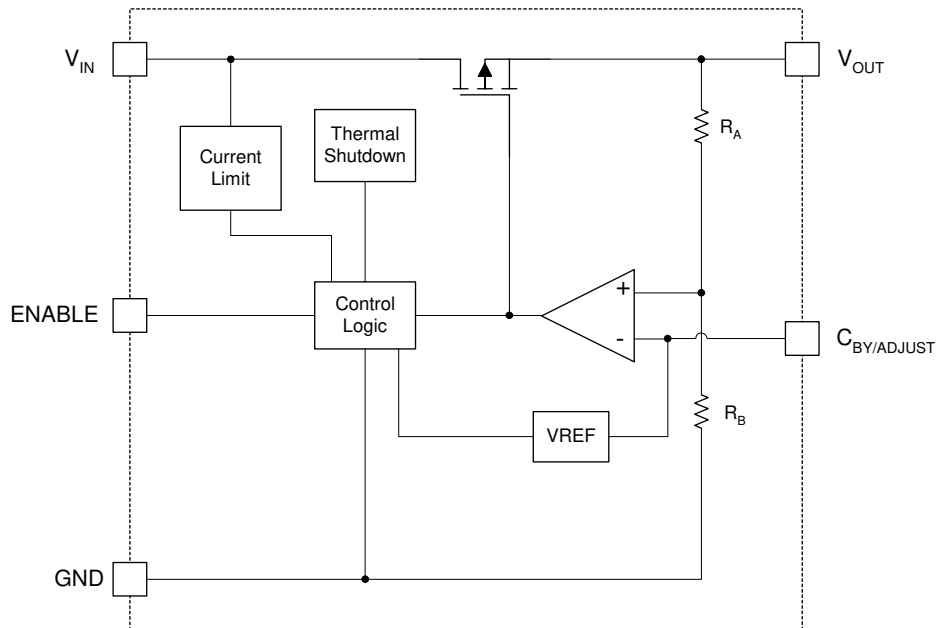
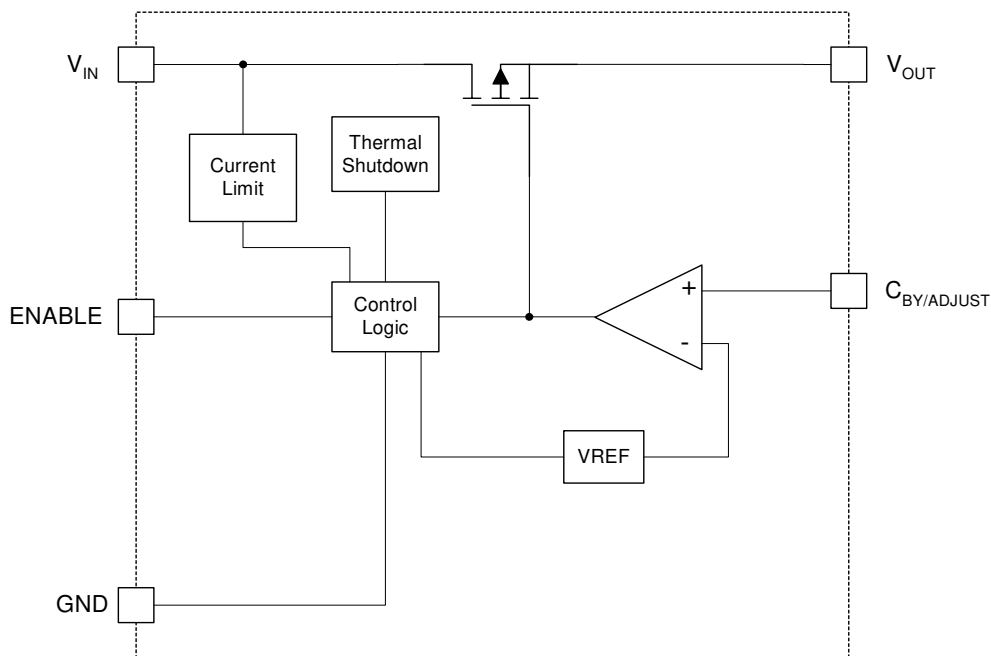
BLOCK DIAGRAM

Figure 2 – Simplified Fixed Version Block Diagram (LX8211-25 / 27 / 28/ 30/ 33ISE)

Figure 3 – Simplified Adjustable Version Block Diagram (LX8211-00ISE)

APPLICATION INFORMATION
Description

The LX8211 is a family of LDO (Low Drop-Out) linear regulators in a small SOT-23 Package, which provides a compact and cost effective solution. The family includes several fixed output voltages, along with an adjustable version. The internal PMOS power device provides low dropout regulation with fast line and load transient response. It also includes internal current limit and thermal shutdown circuitry. In this section you will find information about selection of external capacitors, thermal and layout consideration.

Input Capacitor

To improve load transient response and noise rejection a bypass capacitor is recommended, but it is not required for stability. There are no requirements for the ESR (Equivalent Series Resistor) on the input capacitor, but tolerance and temperature coefficient must be considered when selecting the capacitor to ensure the capacitor will be around 1uF over the entire operating temperature range. For LX8211 connect ceramic type capacitor (1uF) between V_{IN} and ground.

Output Capacitor

To maintain a constant output voltage a feedback loop is necessary. The feedback loop causes a well known phase shift, the amount of phase shift determines the loop stability. Therefore, LX8211 like any low-dropout regulator, requires an output capacitor with low ESR (Equivalent Series Resistor) connected between V_{OUT} and GND to stabilize the internal control loop. For the LX8211 a ceramic, tantalum or electrolytic capacitor with the minimum recommended capacitance value at 1.0 uF with ESR between 5mΩ and 1Ω will satisfy the stability for whole operating range.

Bypass Capacitor (Optional) / Adjustable Output Voltage

The LX8211 includes the extra Bypass pin to help further reduce the already low output noise in the regulator. If the output noise requirement meets the specification, omit the bypass capacitor, that's because the capacitor impacts the start up time which is inversely proportional to the size of bypass capacitor. The bypass capacitor reduces the regulator phase margin, therefore it requires a larger output capacitor to maintain stability.

The LX8211-00 adjustable regulator's output voltage can be externally set by connecting the ADJ pin to an external resistor divider (See Figure 1). The output voltage can be calculated using:

$$V_{OUT} = V_{ADJ} \left(1 + \frac{R1}{R2} \right)$$

Enable

The Enable pin allows the LX8211 to be turned on and off. The Enable pin is compatible with standard TTL-CMOS levels. A logic zero (0.4V) on the Enable pin shuts the LX8211 off and reduces the supply current to less than 1uA. Pulling the Enable input high (2.0V) causes normal operation to resume. If the Enable feature is not used, this pin can be connected to V_{IN} .

Minimum Load Requirement

The LX8211 is stable even at zero load; no minimum load is required for operation, which is especially important in keep-alive applications. However line regulation is improved with a minimum load of 100uA.

Temperature Protection

The thermal protection shuts the LX8211 down when the junction temperature exceeds approximately 150°C, there is no appreciable thermal hysteresis.

Short Circuit Current Protection

The LX8211 includes over current protection, when the output load current exceeds typically 400mA the circuit forces the regulator decrease in output.

Thermal Consideration

Thermal shutdown protects the integrated circuit from thermal overload caused from a rise in junction temperature during power dissipation. This means of protection is intended for fault protection only and not as a means of current or power limiting during normal application usage. Proper thermal evaluation should be done to ensure that the junction temperature does not exceed its maximum rating. Operating at the maximum T_J of 150°C can impact reliability. Due to variation in individual device electrical characteristics and thermal resistance, the built in thermal overload protection may be activated at power levels slightly above or below the rated dissipation.

Power dissipation for regulator can be calculated using the following equation:

$$P_D = (V_{IN(MAX)} - V_{OUT(MIN)}) * I_{OUT(MAX)}$$

(Note: power dissipation resulting from quiescent current is negligible)

For the SOT23 package, thermal resistance, θ_{JA} is 220°C/W when mounted on a FR4 copper clad PCB. Junction temperature of the integrated circuit can be calculated using:

$$T_J = T_A + T_{RISE}, \text{ substituting: } T_A + (P_D * \theta_{JA}).$$

An example: Given conditions: $T_A = 60^\circ\text{C}$, $V_{IN} = 4.2\text{V}$, $V_{OUT} = 2.7\text{V}$, $I_{OUT} = 100\text{mA}$.

Calculated values:

$$\text{Total Power dissipation } P_{D(\text{total})} = (4.2 - 2.7) \text{ V} * 0.1\text{A} = 0.15\text{W}$$

$$\text{Junction Temperature } T_J = 60^\circ\text{C} + (0.15\text{W} * 220^\circ\text{C/W}) = 93^\circ\text{C}$$

Layout Consideration:

The layout must be done with low impedance paths for V_{IN} , V_{OUT} and Ground by applying sufficient wide traces to avoid voltage drops and pick up noise. Adding an area of PCB copper to the GND pin (pin2) will reduce the overall θ_{JA} since it is thermally connected to the device substrate. This will lower the device junction temperature improving the overall output accuracy. The input/output capacitors must be placed as close as possible to the voltage regulator output pin. To allow the same voltage reference for all circuits, use a star configuration from the output capacitor to the different loads.

TYPICAL CHARACTERISTICS

Typical performance characteristics, unless otherwise specified are: $C_{IN} = C_{OUT} = 1\mu F$, $C_{BY} = 470pF$, $V_{IN} = V_{OUT} + 0.5V$, $I_{OUT} = 10mA$, $T_A = 25^\circ C$, ENABLE is tied to V_{IN} .

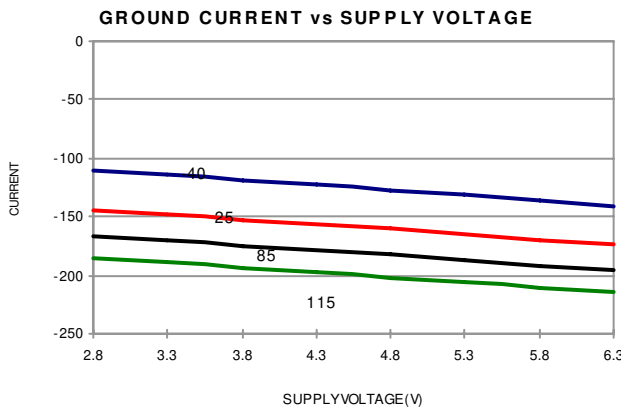
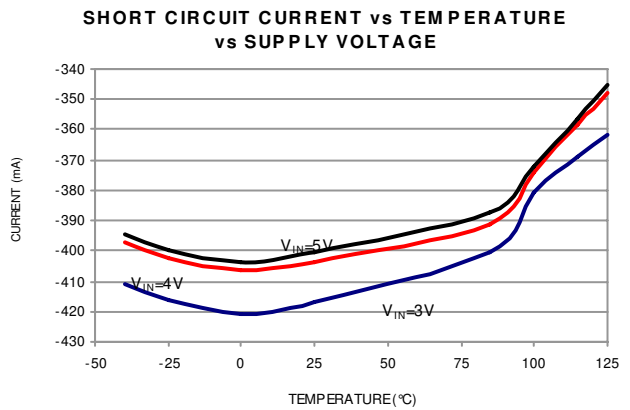
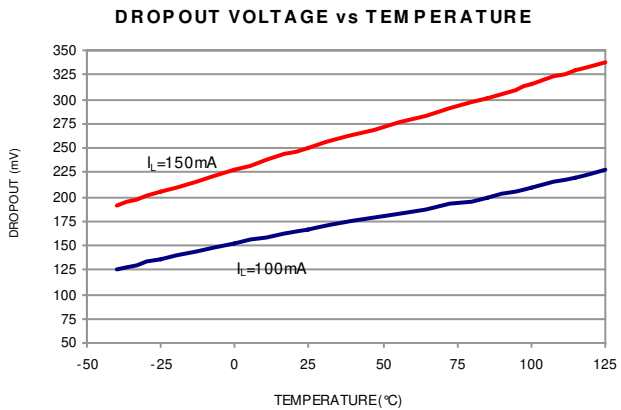
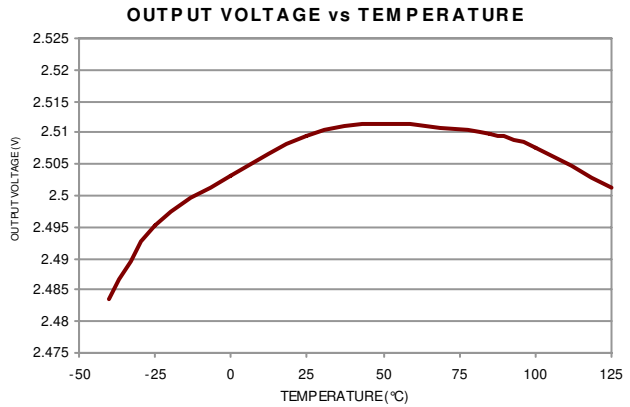
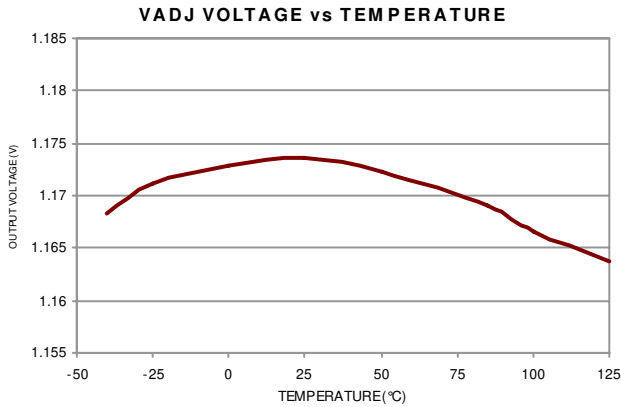
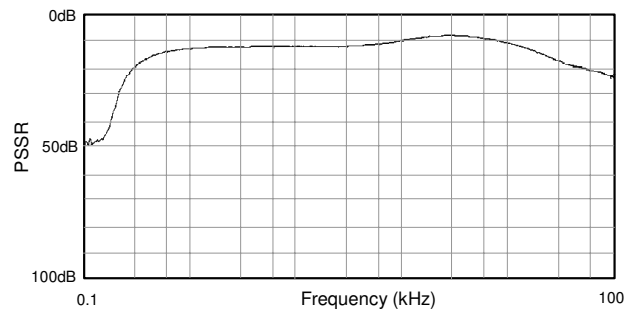
POWER SUPPLY / RIPPLE REJECTION vs FREQUENCY DROPUT REGION

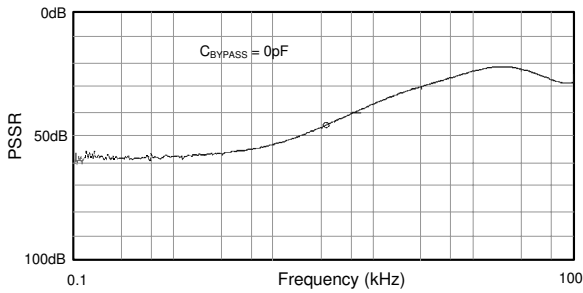
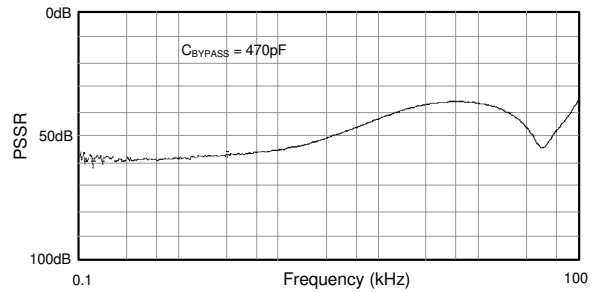
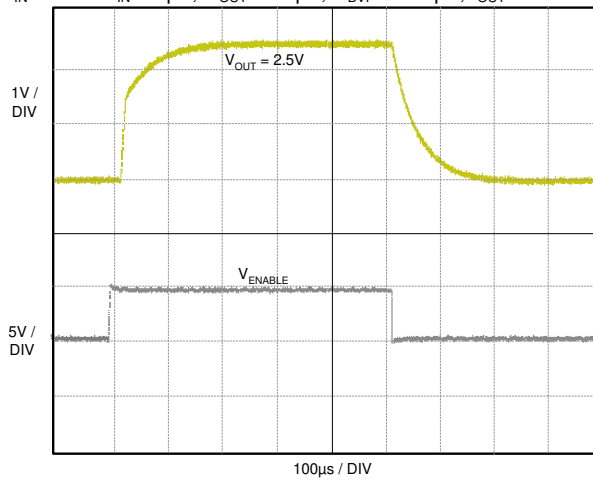
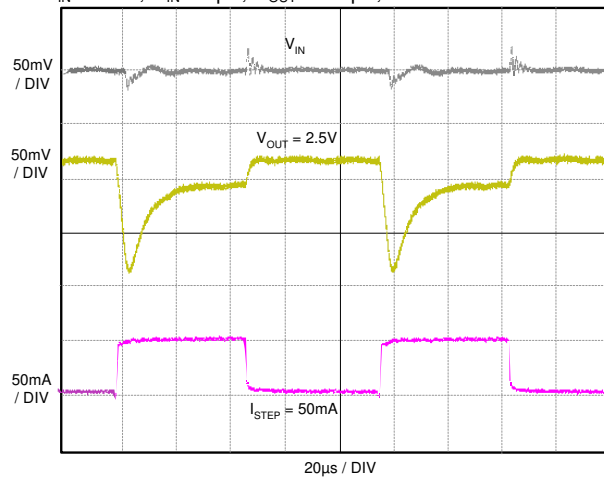
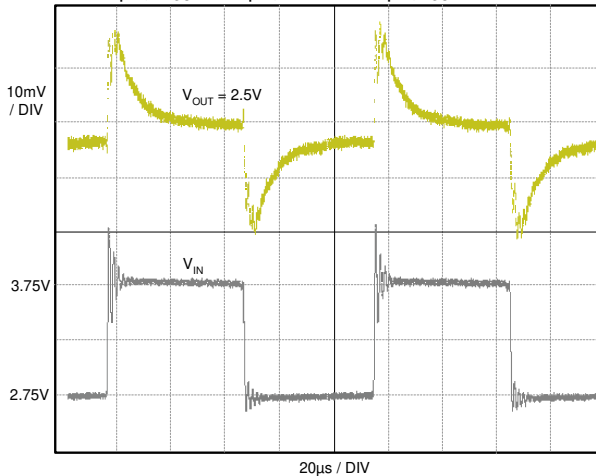
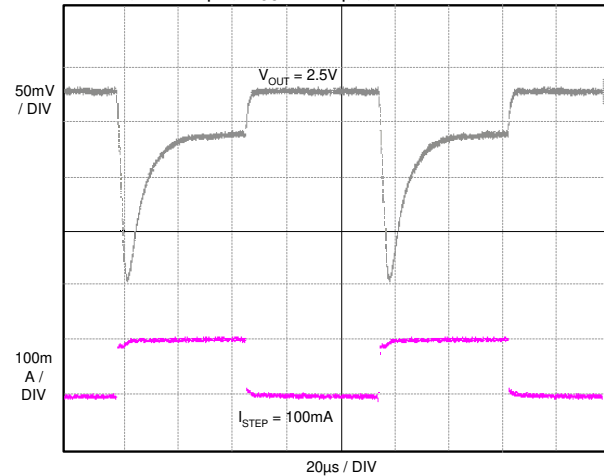
TYPICAL CHARACTERISTICS (CONTINUED)
POWER SUPPLY RIPPLE REJECTION VS. FREQUENCY

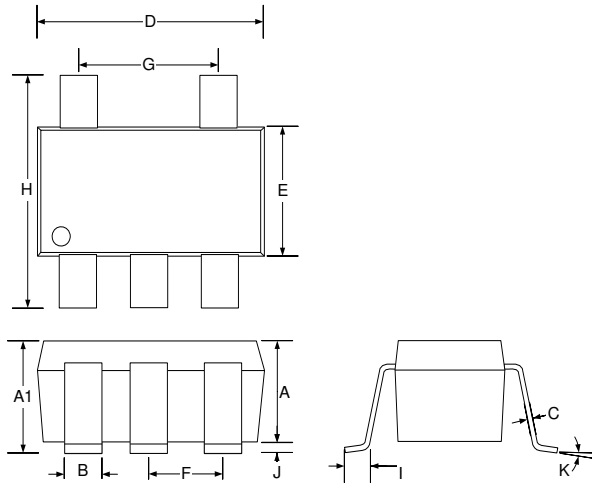
POWER SUPPLY / RIPPLE REJECTION VS. FREQUENCY

ENABLE RESPONSE
 $V_{IN} = 3.3V, C_{IN} = 1\mu F, C_{OUT} = 22\mu F, C_{BVP} = 470pF, I_{OUT} = 100mA$

LOAD TRANSIENT RESPONSE
 $V_{IN} = 3.3V, C_{IN} = 1\mu F, C_{OUT} = 2.2\mu F, STEP Load = 50mA$

LINE REGULATION STEP RESPONSE
 $C_{IN} = 1\mu F, C_{OUT} = 22\mu F, C_{BVP} = 470pF, I_{OUT} = 100mA$

LOAD TRANSIENT RESPONSE
 $V_{IN} = 3.3V, C_{IN} = 1\mu F, C_{OUT} = 2.2\mu F, STEP Load = 100mA$

PACKAGE DIMENSION
SE 5 Pin Plastic SOT-23

Dim	MILLIMETERS		INCHES	
	MIN	MAX	MIN	MAX
A	0.90	1.30	0.035	0.051
A1	0.90	1.45	0.035	0.057
B	0.25	0.50	0.010	0.020
C	0.09	0.20	0.004	0.008
D	2.80	3.10	0.110	0.122
E	1.50	1.75	0.059	0.069
F	0.95 BSC		0.038 BSC	
G	1.90 BSC		0.075 BSC	
H	2.60	3.00	0.102	0.118
I	0.35	0.55	0.014	0.022
J	0.00	0.15	0.000	0.006
K	10° MAX		10° MAX	

Note:

- Dimensions do not include mold flash or protrusions; these shall not exceed 0.155mm(.006") on any side. Lead dimension shall not include solder coverage.



LX8211

150mA CMOS Low Dropout Regulator

PRODUCTION DATA SHEET

NOTES

PRODUCTION DATA – Information contained in this document is proprietary to Microsemi and is current as of publication date. This document may not be modified in any way without the express written consent of Microsemi. Product processing does not necessarily include testing of all parameters. Microsemi reserves the right to change the configuration and performance of the product and to discontinue product at any time.