



Chipsmall Limited consists of a professional team with an average of over 10 year of expertise in the distribution of electronic components. Based in Hongkong, we have already established firm and mutual-benefit business relationships with customers from,Europe,America and south Asia,supplying obsolete and hard-to-find components to meet their specific needs.

With the principle of “Quality Parts,Customers Priority,Honest Operation,and Considerate Service”,our business mainly focus on the distribution of electronic components. Line cards we deal with include Microchip,ALPS,ROHM,Xilinx,Pulse,ON,Everlight and Freescale. Main products comprise IC,Modules,Potentiometer,IC Socket,Relay,Connector.Our parts cover such applications as commercial,industrial, and automotives areas.

We are looking forward to setting up business relationship with you and hope to provide you with the best service and solution. Let us make a better world for our industry!



## Contact us

Tel: +86-755-8981 8866 Fax: +86-755-8427 6832

Email & Skype: info@chipsmall.com Web: www.chipsmall.com

Address: A1208, Overseas Decoration Building, #122 Zhenhua RD., Futian, Shenzhen, China



### 1. Features

- Buck-Boost DC-DC converter
- Low EMI noise and small footprint using inductor-embedded ferrite substrate
- High efficiency using synchronous rectifier technology at 2.5MHz operation
- Wide Input voltage range : 2.8~5.0V
- Output voltage:3.3V
- Maximum load current: 1,200mA
- Automatic transition between buck mode and boost mode
- Fully protected for short-circuit, over-temperature, and under voltage

### 2. Description

The LXDC2SCAAB-352 is a buck-boost DC-DC converter, which is suitable for a space-limited or a noise-sensitive portable application. The device utilizes an inductor-embedded ferrite substrate, and the substrate eliminates radiated EMI noise and conduction noise efficiently.

The LXDC2SCAAB-352 has automatic buck-boost operations to prolong Li-ion battery life and efficiency. By switching automatically between the buck-mode operation (stepping down the voltage) when the battery is fully charged and the boost-mode operation (stepping up the voltage) as the battery is discharged, the LXDC2SCAAB-352 maximizes the overall operating voltage from the lithium battery.

### 3. Typical Application Circuit

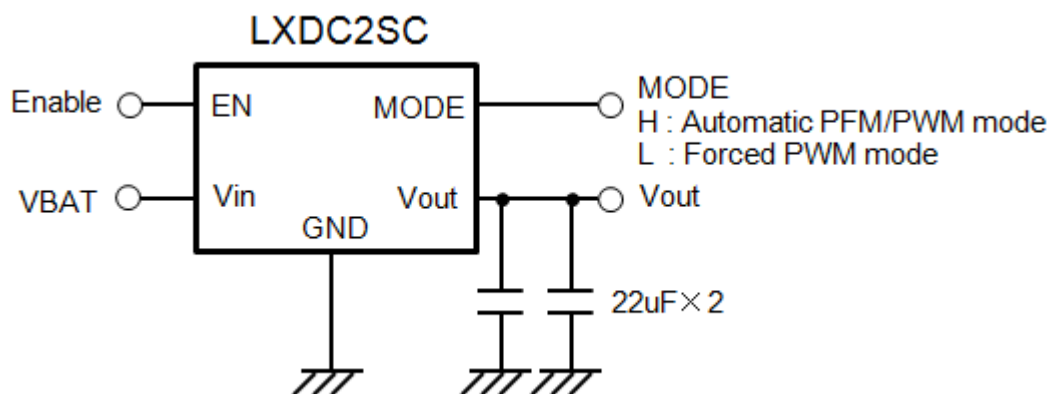

### 4. Mechanical details

#### 4-1 Outline

Top View

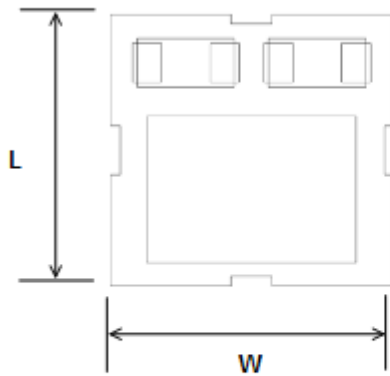

Bottom View

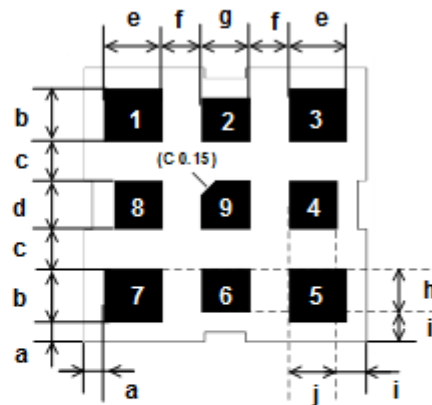

Side View

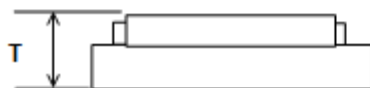

Unit : mm

Symbol	Dimension	Symbol	Dimension
L	2.8±0.2	d	0.5±0.1
W	2.9±0.2	e	0.54±0.1
T	1.15MAX	f	0.4±0.1
		g	0.5±0.1
a	0.26±0.2	h	0.39±0.1
b	0.49±0.1	i	0.36±0.2
c	0.4±0.1	j	0.44±0.1

#### 4-2 Pin Function

Pin No.	Symbol	I/O	Description
1	MODE	Input	Mode=H: auto PFM mode Mode=L: Forced PWM mode
2,5,6,9	GND	—	Ground pin
3,4	Vout	Output	Regulated voltage output pin.
7	EN	Input	ON/OFF control pin EN=H: Device ON, EN=L: Device OFF
8	Vin	Input	Vin pin supplies current to the LXDC2SC internal regulator.

**4-3 Functional Block Diagram**

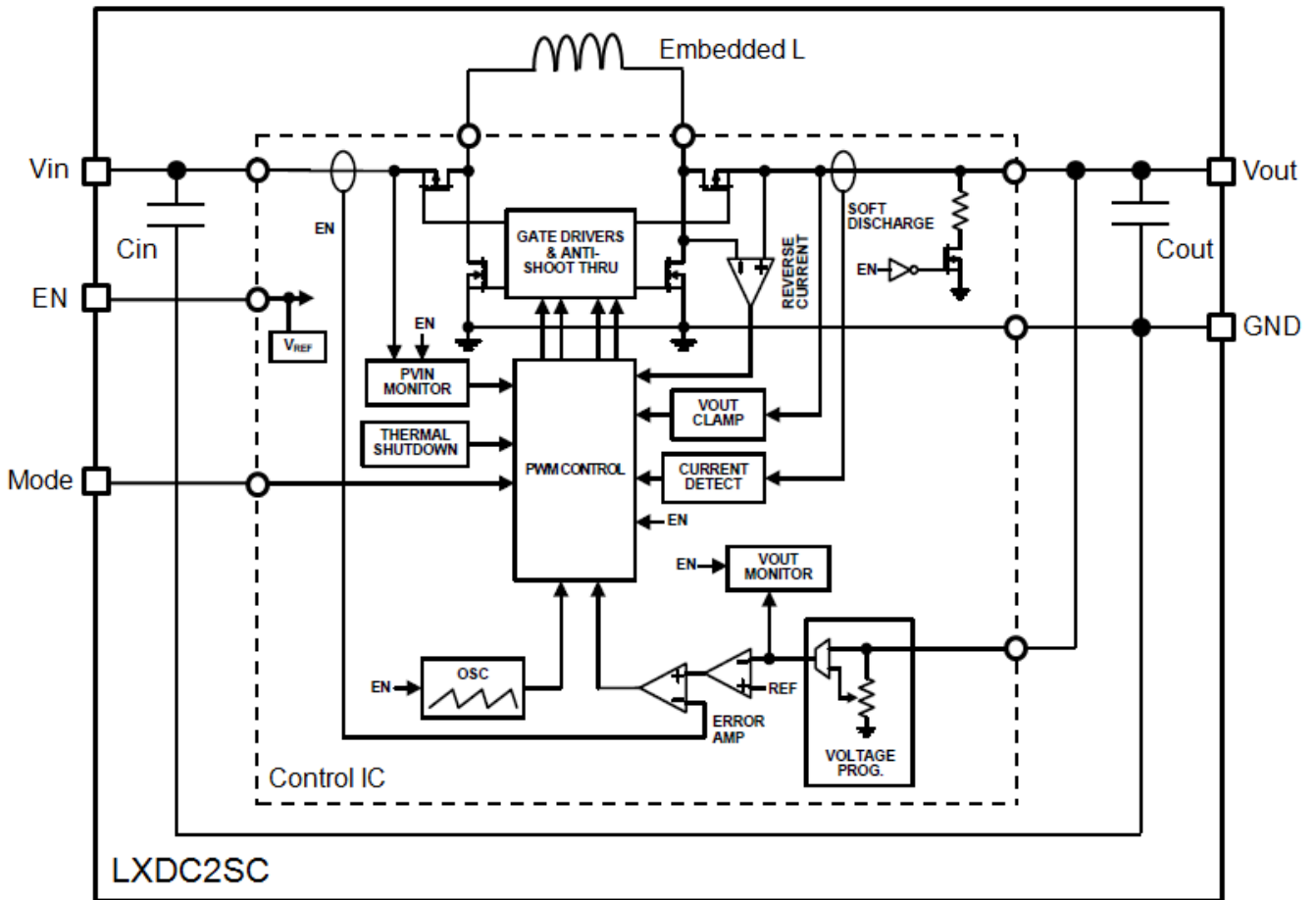

**5. Ordering Information**

Part number	Device Specific Feature	MOQ
LXDC2SCAAB-352	Standard Type	T/R, 2,500pcs/R



## 6. Electrical Specification

### 6-1 Absolute maximum ratings

Parameter	symbol	rating	Unit
Input voltage	V <sub>in</sub>	6.3	V
Pin voltage	EN, MODE	6.3	V
Operating Ambient temperature	T <sub>OP</sub>	-40 to +85	°C
Operating IC temperature	T <sub>IC</sub>	-40 to +125	°C
Storage temperature	T <sub>STO</sub>	-40 to +85	°C

### 6-2 Electrical characteristics (T<sub>a</sub>=25°C)

Parameter	Symbol	Condition	Min.	Typ.	Max.	Unit
Input voltage	V <sub>in</sub>		2.8		5.0	V
UVLO voltage	UVLO	Rising		1.75	1.795	V
		Falling	1.60	1.71		
Input leak current	I <sub>inoff</sub>	V <sub>in</sub> =3.8V, EN=0V			2	uA
Output voltage accuracy	V <sub>out</sub>	PWM mode	3.217	3.3	3.383	V
Load current range	I <sub>out</sub>	V <sub>in</sub> =3.8V			1.2	A
Ripple voltage	V <sub>rpl</sub>	V <sub>in</sub> =3.8V, I <sub>out</sub> =100mA, BW=100MHz		20		mV <sub>pp</sub>
Efficiency	EFF	V <sub>in</sub> =3.8V, I <sub>out</sub> =100mA EN=H, MODE=H		95		%
EN control voltage	VENH	ON: Enable	1.4		V <sub>in</sub>	V
	VENL	OFF: Disable	0		0.4	
MODE control Voltage	VMODEH	Automatic PFM/PWM mode	1.4	-	V <sub>in</sub>	V
	VMODEL	Forced PWM mode	0	-	0.4	
SW Frequency	F <sub>osc</sub>			2.5		MHz

(\*1) External capacitors (C<sub>out</sub>: 22uF × 2) should be placed near the module for proper operation.

(\*2) The above characteristics are tested using the test circuit in section 8.

### 6-3 Thermal and Current De-rating Information

The following figure shows the power dissipation and temperature rise characteristics example. These data are measured on Murata's evaluation board of this device at no air-flow condition.

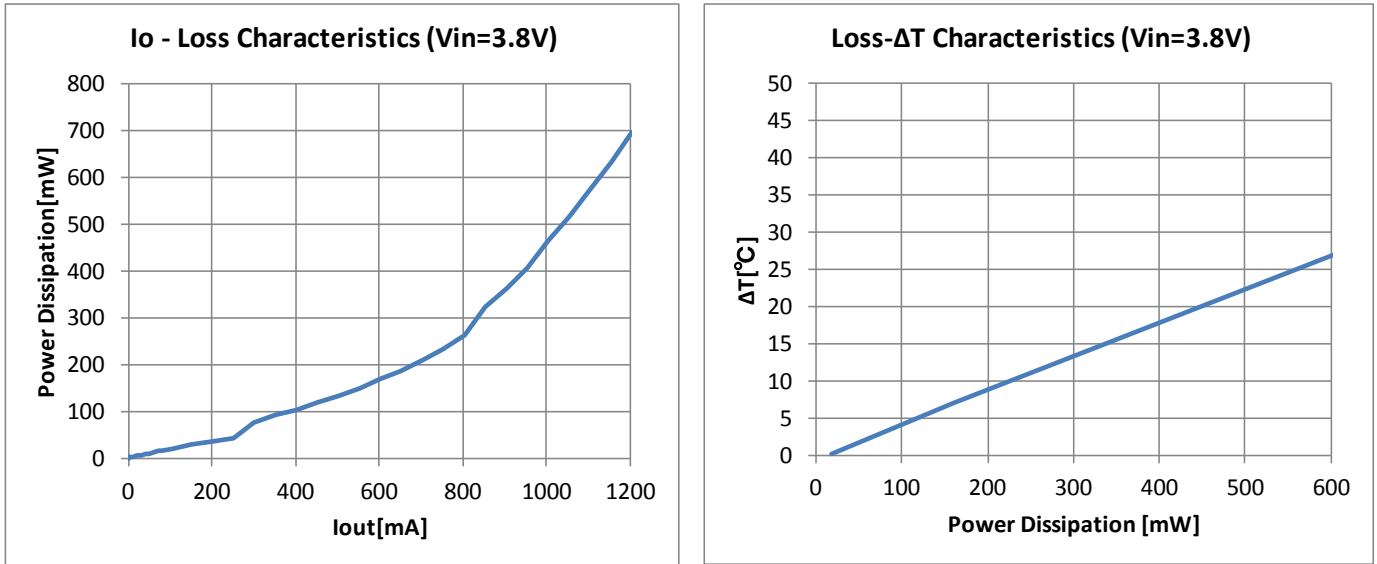

The output current of the device may need to be de-rated if it is operated in a high ambient temperature or in a continuous power delivering application. The amount of current de-rating is highly dependent on the environmental thermal conditions, i.e. PCB design, nearby components or effective air flows. Care should especially be taken in applications where the device temperature exceeds 85°C.

The IC temperature of the device must be kept lower than the maximum rating of 125 °C. It is generally recommended to take an appropriate de-rating to IC temperature for a reliable operation. A general de-rating for the temperature of semiconductor is 80%.

MLCC capacitor's reliability and lifetime are also depending on temperature and applied voltage stress. Higher temperature and/or higher voltage cause shorter lifetime of MLCC, and the degradation can be described by the Arrhenius model. The most critical parameter of the degradation is IR (Insulation Resistance). The below figure shows MLCC's B1 life based on a failure rate reaching 1%. It should be noted that wear-out mechanisms in MLCC capacitor is not reversible but cumulative over time.

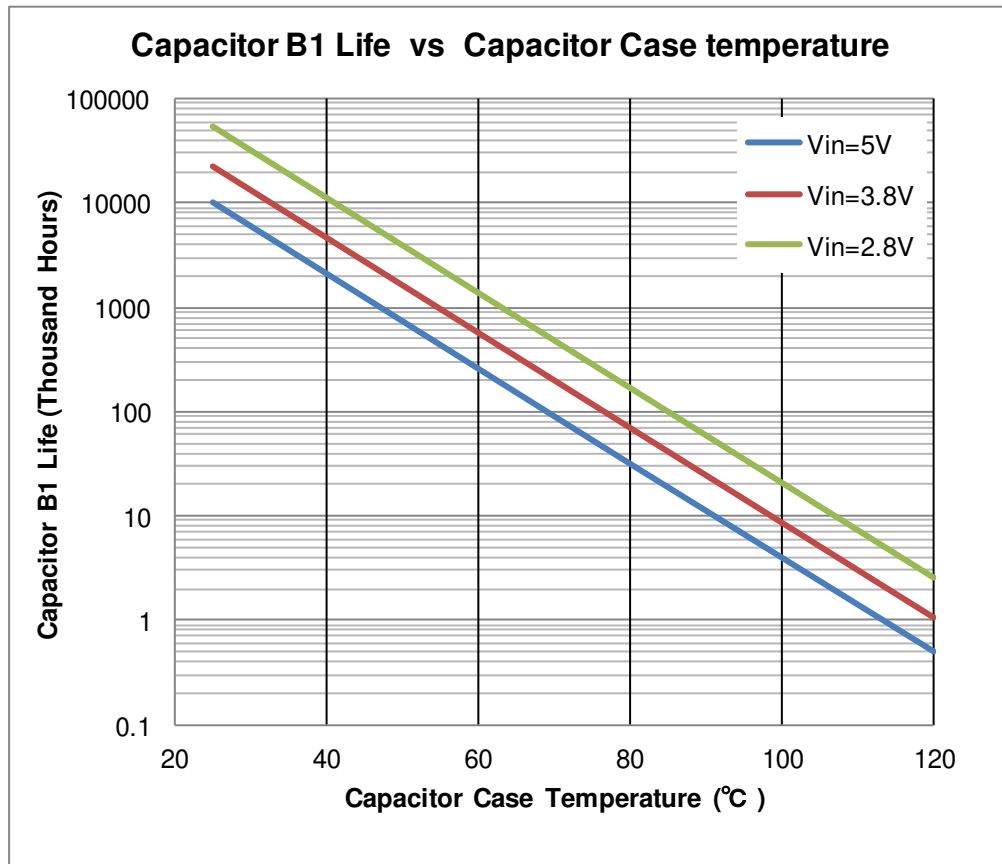

The following steps should be taken before the design fix of user's set for a reliable operation.

1. The ambient temperature of the device should be kept below 85 °C
2. The IC temperature should be measured on the worst condition of each application. The temperature must be kept below 125 °C. An appropriate de-rating of temperature and/or output current should be taken.
3. The MLCC temperature should be measured on the worst condition of each application. Considering the above figure, it should be checked if the expected B1 life of MLCC is acceptable or not.

## 7. Detailed Description

### Automatic buck-boost operations

The LXDC2SCAAB uses 4-switch buck-boost circuit topology. The device compares the input and output voltage, and chooses the buck converter mode or boost converter mode automatically. Its transition is very smooth and seamless.

### Enable

The device starts operation when EN is set high and starts up with soft start. For proper operation, the EN pin must be terminated to logic high and must not be left floating. Pulling the EN pin to logic low forces the device into shutdown mode.

### Mode selection

The MODE pin allows selecting the operating mode. If the MODE pin is pulled to logic high voltage (V<sub>MODH</sub>), the converter operates automatic PFM and PWM mode. In this mode, the converter operates in PFM mode at light load current, and when the load current increase, the operating mode will change to PWM mode automatically. In this mode, the converter can work in high efficiency over wide load current range.

If the MODE pin is pulled to logic low voltage (V<sub>MODL</sub>), the device operates in PWM forced mode. In this mode, the converter operates in PWM mode with the full load current range. The advantage of this mode is that the converter operates with the fixed frequency that allows simple filtering of switching frequency. In this mode, the efficiency is lower compared to the PFM mode at light load current.

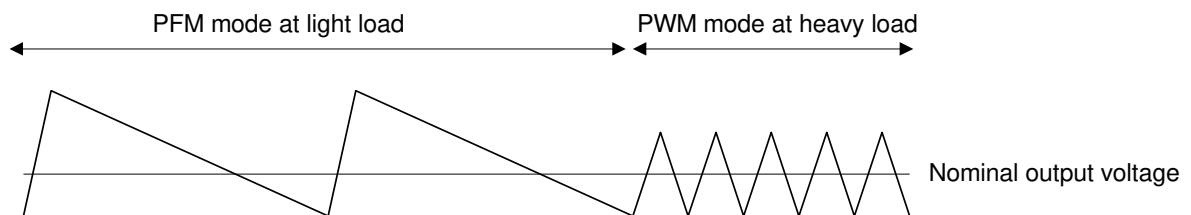

### UVLO (Under Voltage Lock Out)

The under voltage lockout circuit prevents the device from malfunctioning at low input voltages and the battery from excessive discharge. It disables the output stage of the converter once the falling  $V_{IN}$  trips the under-voltage lockout threshold  $V_{UVLO}$  which is typically 1.65V. The device starts operation once the rising  $V_{IN}$  trips  $V_{UVLO}$  threshold plus its hysteresis of 75 mV at typ. 1.725V.

### Soft Start

The device has an internal soft-start function that limits the inrush current during start-up. The soft-start system progressively increases the switching on-time from a minimum pulse-width to that of normal operation. Because of this function, the output voltage increases gradually from zero to nominal voltage at start-up event. The nominal soft-start time is 3msec.



**Discharge Function**

To make sure the device starts up under defined conditions, the output gets discharged with a typical discharge resistor of 120  $\Omega$  whenever the device shuts down. This happens when the device is disabled or any of the protection function (thermal shutdown, under voltage lockout, over current) is triggered.

**Over Current Protection**

The converter has a hiccup-mode over current protection function.

When the current in the P-Channel MOSFET is sensed to reach the current limit for 16 consecutive switching cycles, the internal protection circuit is triggered, and switching is stopped for approximately 40ms. The device then performs a soft-start cycle.

**Thermal Shutdown**

As soon as the internal IC's junction temperature exceeds 150°C (typ), the device goes into thermal shutdown. The device returns to its normal operation when the Internal IC's junction temperature again falls below 120 °C(typ).

**8. Test Circuit**

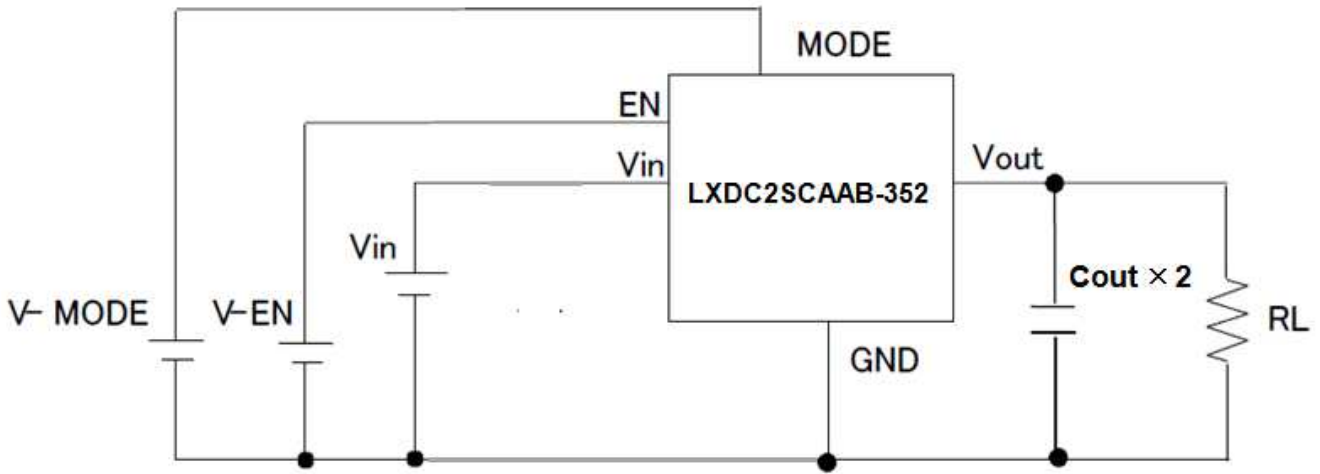

Cout: 22uF/6.3V GRM155R60J226M / GRM188R60J226M

## 9. Measurement Data

### Micro DC-DC Converter evaluation board

#### Measurement setup

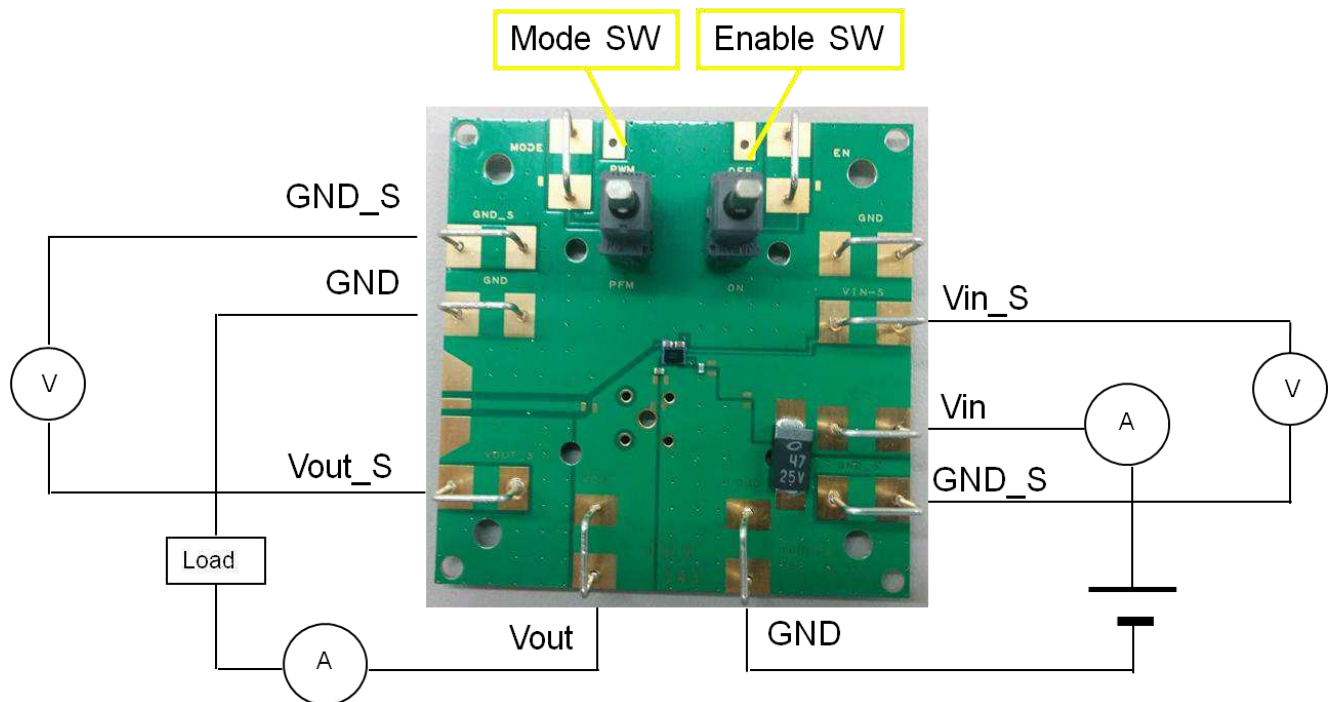

The enable switch has three positions.

1. When it is toggled "ON", the device starts operation.
2. When it is toggled "OFF", the device stops operation and stays in shut down mode.
3. When it is set to the middle of "ON" and "OFF", the EN pin becomes floating and can be can have an external voltage applied through the EN terminal pin on the EVB. If you don't apply an external voltage to the EN pin, the enable switch should not to be set to the middle position.

The mode switch has three states (PWM, PFM, and Open).

1. When it is shorted to "PWM" side, the device operates in PWM forced mode.
2. When it is shorted to "PFM" side, the device operates in PFM/PWM automatic mode.
3. When it is set to open, the mode pin becomes floating and can have an external voltage applied to it through the Mode terminal pin on the EVB. If you don't apply external voltage to the Mode pin, the mode switch should not to be set to the middle position.

※The 47uF capacitor is for the evaluation kit only, and has been added to compensate for the long test cables.

**Typical Measurement Data (reference purpose only) (Ta=25°C)**

**Efficiency**

Vin=3.8V,

PFM/PWM Operation

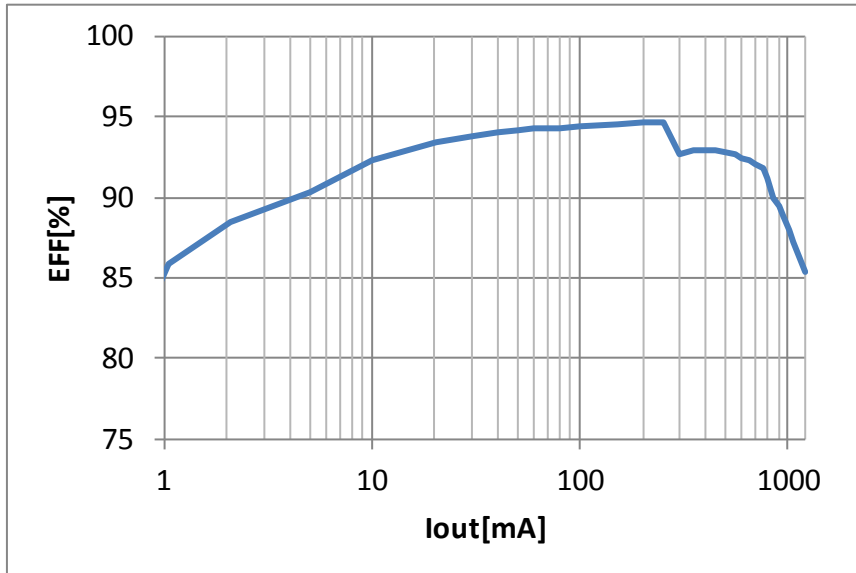

**Output Ripple-Noise**

Vin=3.8V, BW : 100MHz

PFM/PWM Operation

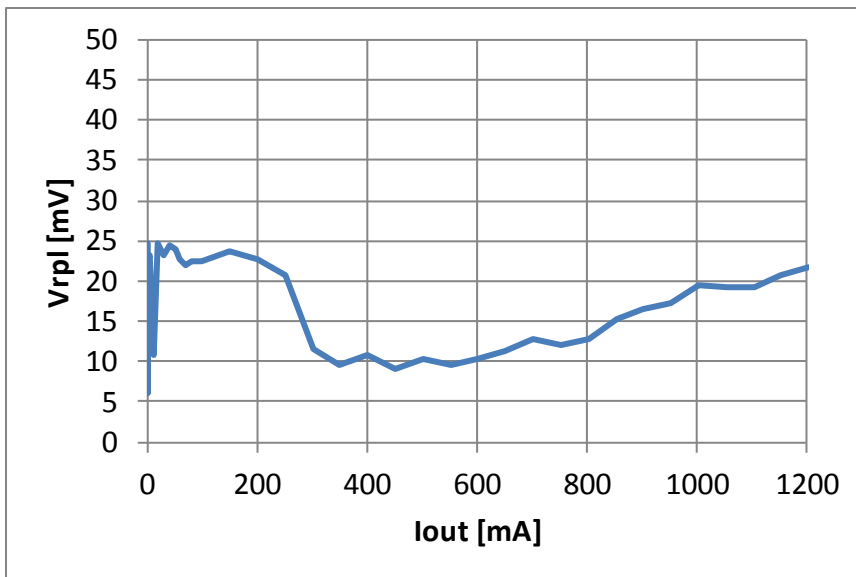

### Load Regulation

Vin=3.8V

PFM/PWM Operation

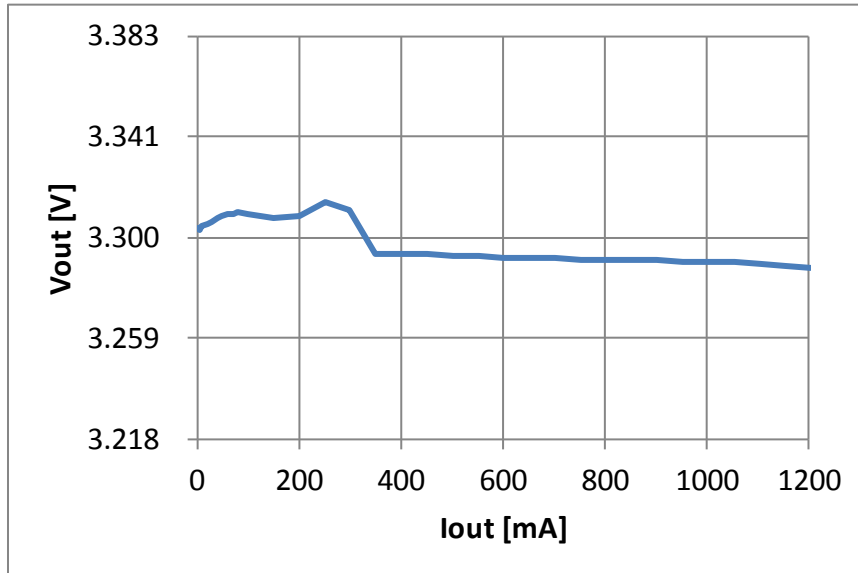

### Load Transient Response

Vin=3.8V,

PFM/PWM Operation

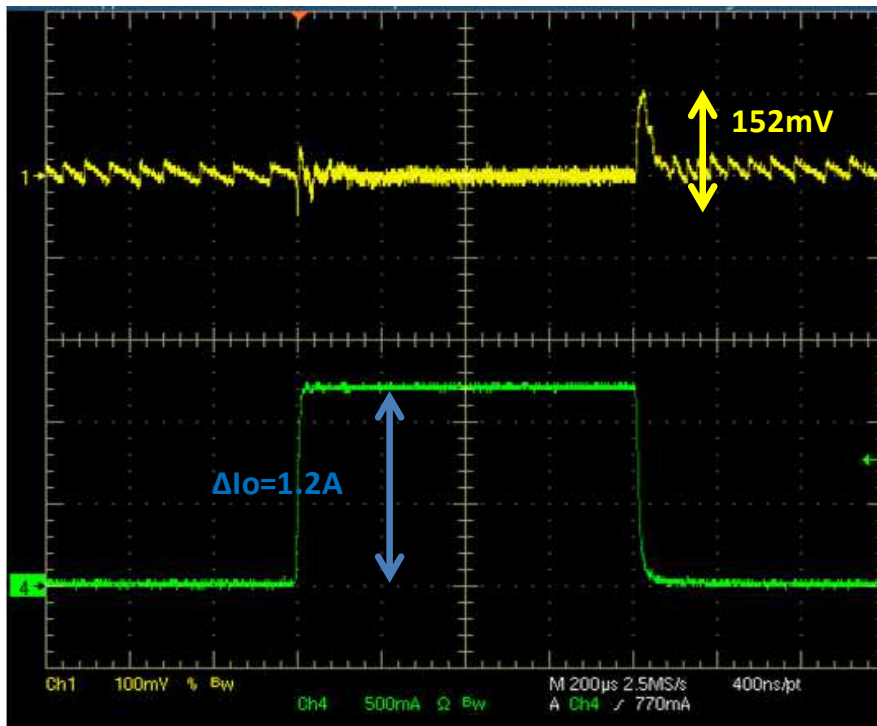

## 10. Reliability Tests

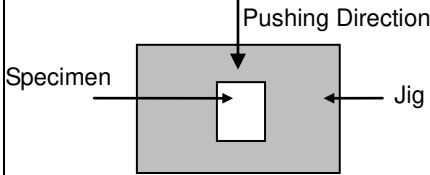
No.	Items	Specifications	Test Methods	QTY	Result (NG)
1	Vibration Resistance	Appearance : No severe damages	Solder specimens on the testing jig (glass fluorine boards) shown in appended Fig.1 by a Pb free solder. The soldering shall be done either by iron or reflow and be conducted with care so that the soldering is uniform and free of defect such as by heat shock.  Frequency : 10~2000 Hz Acceleration : 196 m/s <sup>2</sup> Direction : X,Y,Z 3 axis Period : 2 h on each direction Total 6 h.	18	G (0)
2	Deflection		Solder specimens on the testing jig (glass epoxy boards) shown in appended Fig.2 by a Pb free solder. The soldering shall be done either by iron or reflow and be conducted with care so that the soldering is uniform and free of defect such as by heat shock. Deflection : 1.6mm	18	G (0)
3	Soldering strength (Push Strength)	9.8 N Minimum	Solder specimens onto test jig shown below. Apply pushing force at 0.5mm/s until electrode pads are peeled off or ceramics are broken. Pushing force is applied to longitudinal direction.  	18	G (0)
4	Solderability of Termination	75% of the terminations is to be soldered evenly and continuously.	Immerse specimens first an ethanol solution of rosin, then in a Pb free solder solution for 3±0.5 sec. at 245±5 °C. Preheat : 150 °C, 60 sec. Solder Paste : Sn-3.0Ag-0.5Cu Flux : Solution of ethanol and rosin (25 % rosin in weight proportion)	18	G (0)
5	Resistance to Soldering Heat (Reflow)	Appearance  Electrical specifications	No severe damages  Satisfy specifications listed in paragraph 6-2.	18	G (0)
			Preheat Temperature : 150-180 °C Preheat Period : 90+/-30 sec. High Temperature : 220 °C High Temp. Period : 20sec. Peak Temperature : 260+5/-0 °C Specimens are soldered twice with the above condition, and then kept in room condition for 24 h before measurements.		



No.	Items	Specifications	Test Methods	QTY	Result (NG)									
6	High Temp. Exposure	Appearance Electrical specifications No severe damages Satisfy specifications listed in paragraph 6-2.	Temperature: 85±2 °C Period: 1000+48/-0 h Room Condition: 2~24h	18	G (0)									
7	Temperature Cycle		Condition: 100 cycles in the following table <table border="1" data-bbox="826 555 1206 815"> <thead> <tr> <th>Step</th> <th>Temp(°C)</th> <th>Time(min)</th> </tr> </thead> <tbody> <tr> <td>1</td> <td>Min. Operating Temp.+0/-3</td> <td>30±3</td> </tr> <tr> <td>2</td> <td>Max. Operating Temp.+3/-0</td> <td>30±3</td> </tr> </tbody> </table>	Step	Temp(°C)	Time(min)	1	Min. Operating Temp.+0/-3	30±3	2	Max. Operating Temp.+3/-0	30±3	18	G (0)
Step	Temp(°C)		Time(min)											
1	Min. Operating Temp.+0/-3		30±3											
2	Max. Operating Temp.+3/-0		30±3											
8	Humidity (Steady State)		Temperature: 85±2 °C Humidity: 80~90%RH Period: 1000+48/-0 h Room Condition: 2~24h	18	G (0)									
9	Low Temp. Exposure	Temperature: -40±2 °C Period: 1000+48/-0 h Room Condition: 2~24h	18	G (0)										
10	ESD(Machine Model)	C: 200pF, R: 0Ω TEST Voltage : +/-100V Number of electric discharges: 1	5	G (0)										
11	ESD(Human Body Model)	C: 100pF, R: 1500Ω TEST Voltage : +/-1000V Number of electric discharges: 1	5	G (0)										

Fig.1

Land Pattern

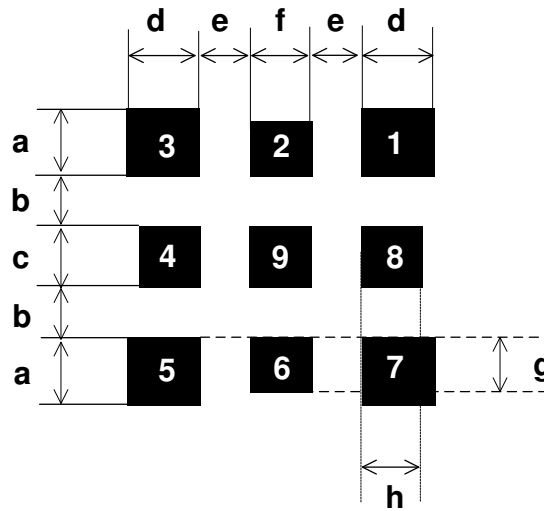

Unit: mm

Symbol	Dimension	Symbol	Dimension
a	0.55	e	0.4
b	0.4	f	0.5
c	0.5	g	0.45
d	0.6	h	0.5

- Reference purpose only.

Fig.2  
Testing board

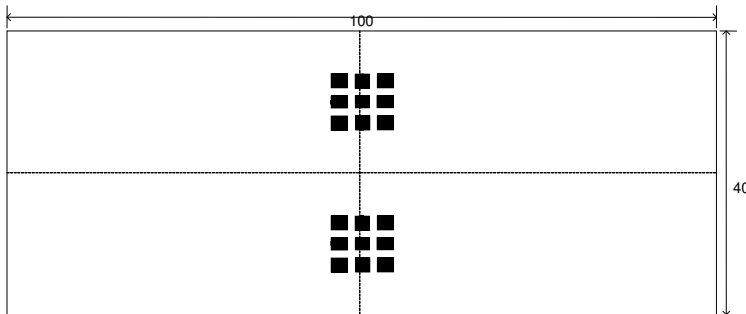

Unit : mm

■ : Land pattern is same as figure 1  
Glass-fluorine board  $t=1.6\text{mm}$   
Copper thickness over  $35\ \mu\text{m}$

Mounted situation

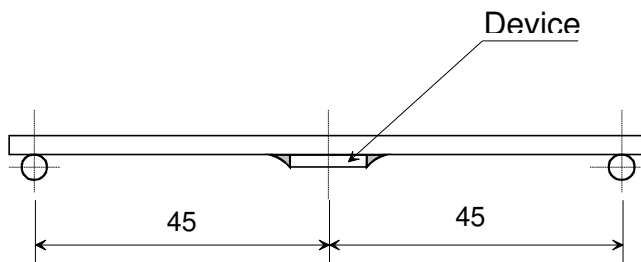

Unit : mm

Test method

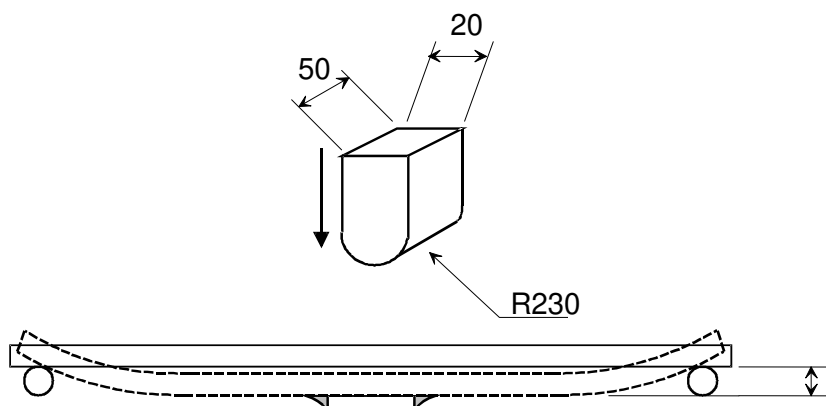

Unit : mm

deflection

## 11. Tape and Reel Packing

### 1) Dimensions of Tape (Plastic tape)

Unit: mm

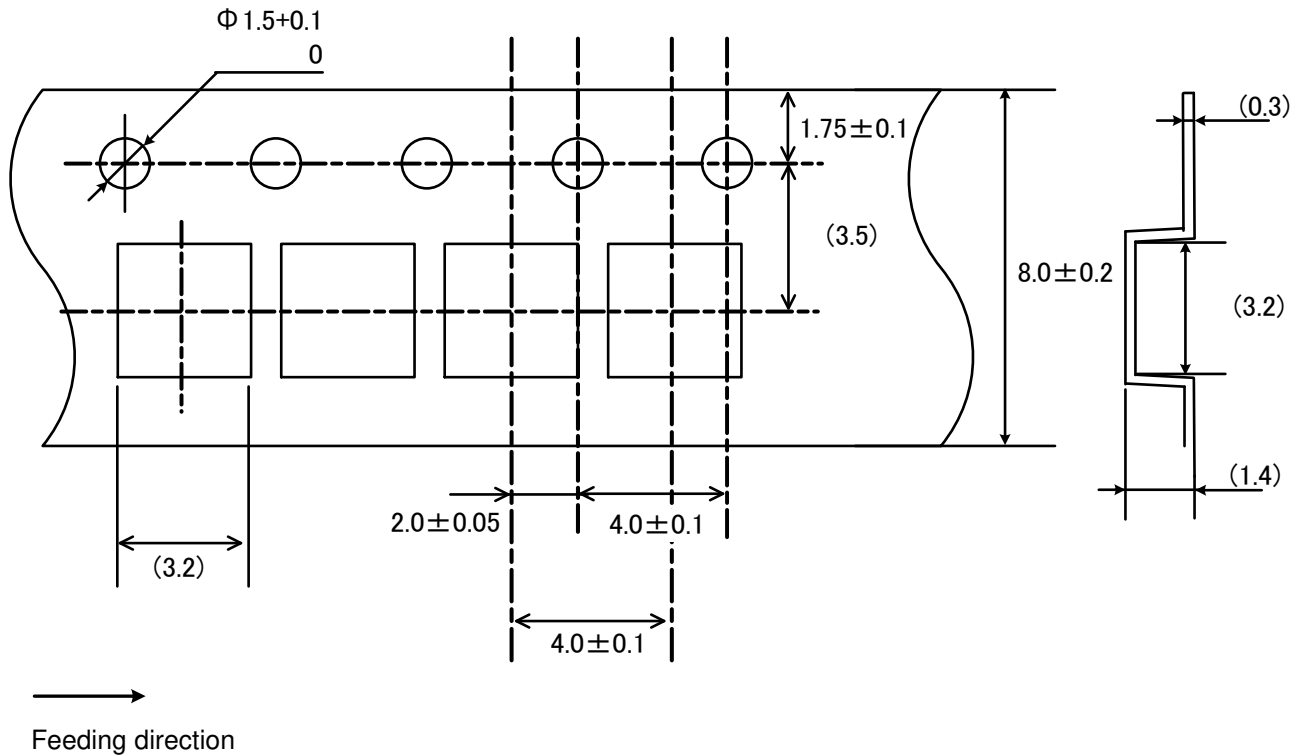

### 2) Dimensions of Reel

Unit: mm

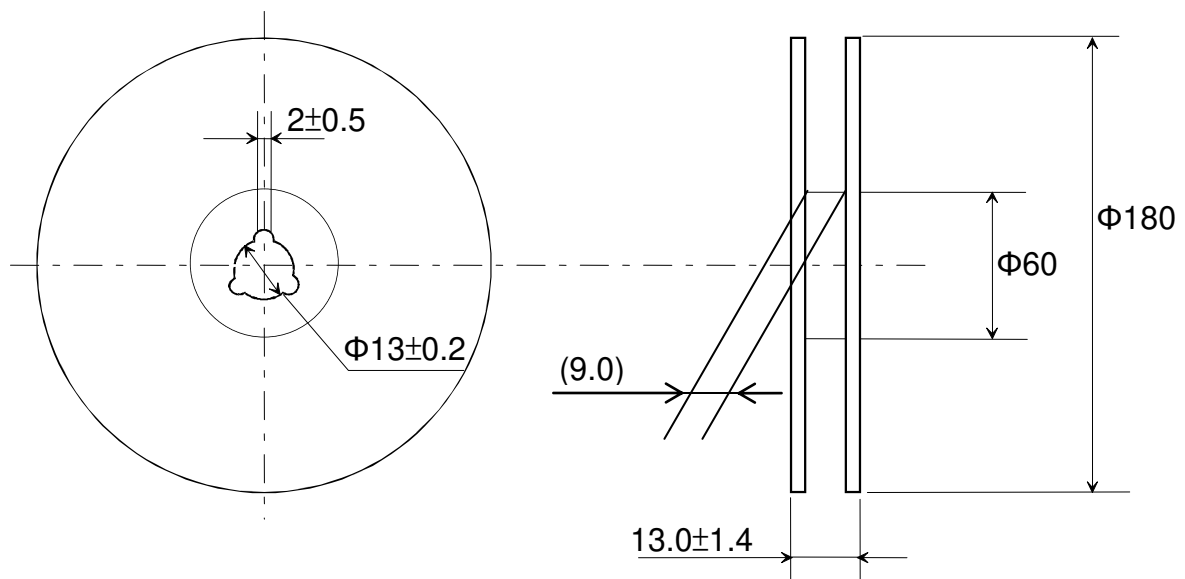

### 3) Taping Diagrams

- [1] Feeding Hole : As specified in (1)
- [2] Hole for chip : As specified in (1)
- [3] Cover tape : 50um in thickness
- [4] Base tape : As specified in (1)

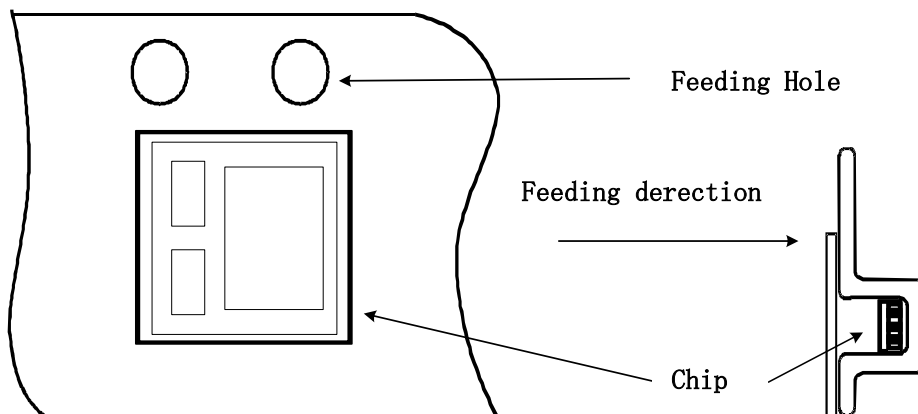
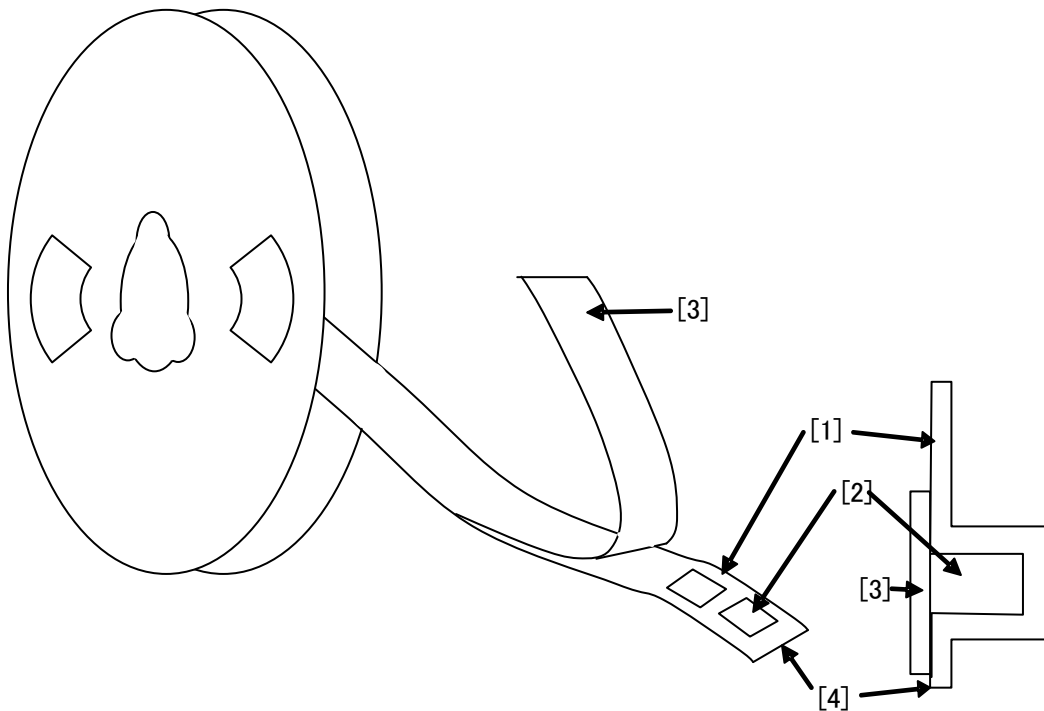

4) Leader and Tail tape

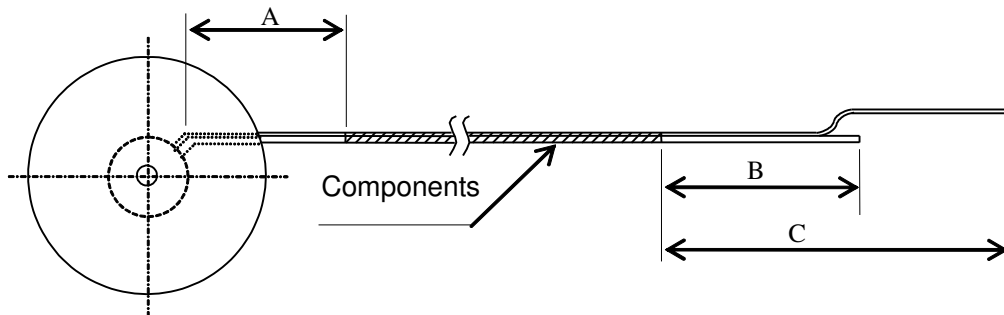

Symbol	Items	Ratings(mm)
A	No components at trailer	min 160
B	No components at leader	min 100
C	Whole leader	min 400

5) The tape for modules is wound clockwise with the feeding holes to the right side as the tape is pulled towards the user.

6) Packaging unit: :2,500 pcs./ reel

7) Material :     Base Tape     ... Plastic  
                   Reel             ... Plastic  
                   Antistatic coating for both base tape and reel

8) Peeling of force

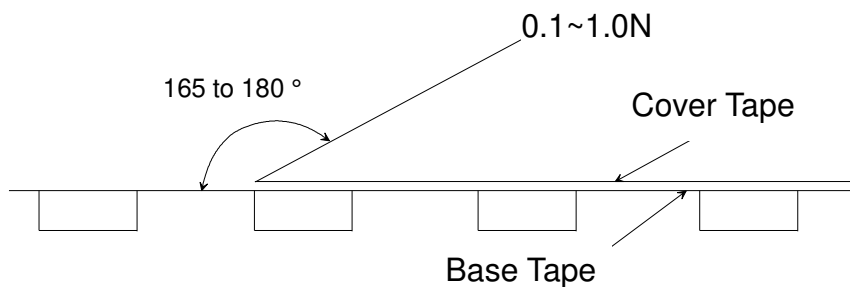



## NOTICE

### 1. Storage Conditions:

To avoid damaging the solderability of the external electrodes, be sure to observe the following points.

- Store products where the ambient temperature is 15 to 35 °C and humidity 45 to 75% RH.  
(Packing materials, In particular, may be deformed at the temperature over 40 °C.).
- Store products in non corrosive gas (Cl<sub>2</sub>, NH<sub>3</sub>, SO<sub>2</sub>, NO<sub>x</sub>, etc.).
- Stored products should be used within 6 months of receipt. Solderability should be verified if this period is exceeded

This product is applicable to MSL1 (Based on IPC/JEDEC J-STD-020)

### 2. Handling Conditions:

Be careful in handling or transporting the product. Excessive stress or mechanical shock may damage the product because of the nature of ceramics structure.

Do not touch the product, especially the terminals, with bare hands. Doing so may result in poor solderability.

### 3. Standard PCB Design (Land Pattern and Dimensions):

All the ground terminals should be connected to ground patterns. Furthermore, the ground pattern should be provided between IN and OUT terminals. Please refer to the specifications for the standard land dimensions.

The recommended land pattern and dimensions are shown for a reference purpose only. Electrical, mechanical and thermal characteristics of the product shall depend on the pattern design and material / thickness of the PCB. Therefore, be sure to check the product performance in the actual set. When using underfill materials, be sure to check the mechanical characteristics in the actual set.

**4. Soldering Conditions:**

Soldering is allowed up through 2 times.

Carefully perform preheating :  $\Delta T$  less than 130 °C.

When products are immersed in solvent after mounting, pay special attention to maintain the temperature difference within 100 °C. Soldering must be carried out by the above mentioned conditions to prevent products from damage. Contact Murata before use if concerning other soldering conditions.

**Reflow soldering standard conditions (example)**

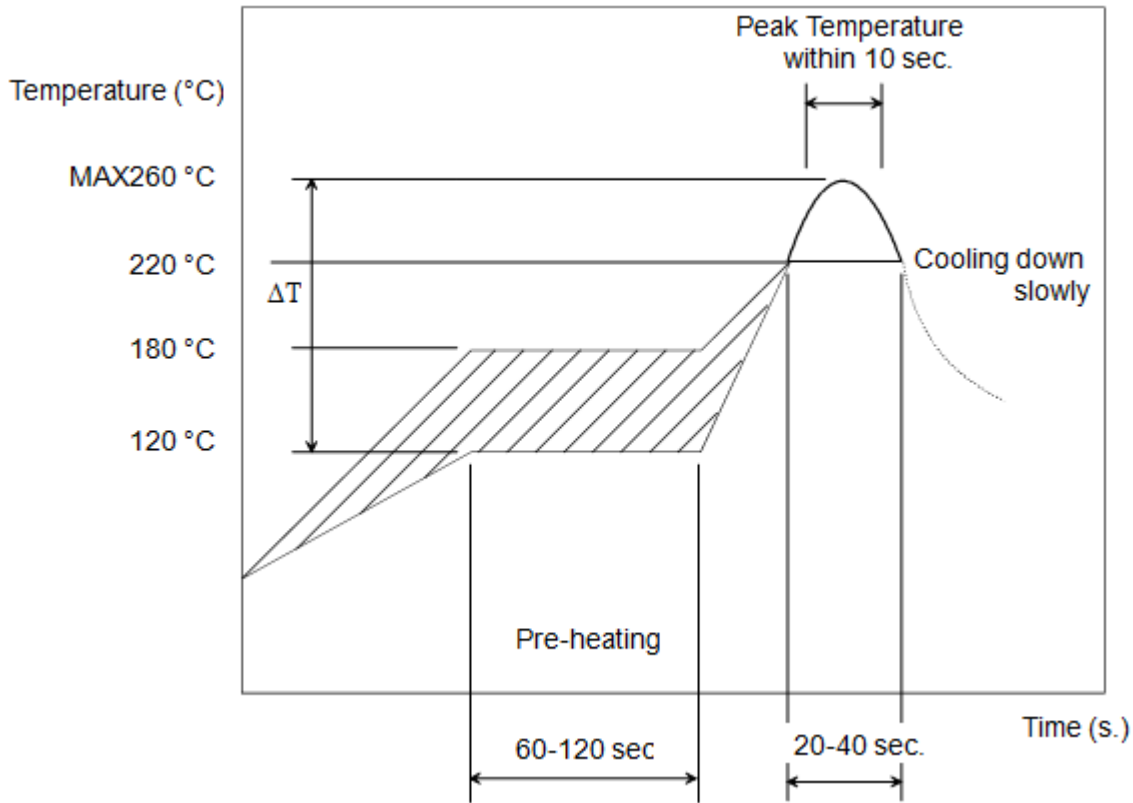

Use rosin type flux or weakly active flux with a chlorine content of 0.2 wt % or less.

## 5. Cleaning Conditions:

The product is not designed to be cleaned after soldering.

## 6. Operational Environment Conditions:

Products are designed to work for electronic products under normal environmental conditions (ambient temperature, humidity and pressure). Therefore, products have no problems to be used under the similar conditions to the above-mentioned. However, if products are used under the following circumstances, it may damage products and leakage of electricity and abnormal temperature may occur.

- In an atmosphere containing corrosive gas ( Cl<sub>2</sub>, NH<sub>3</sub>, SO<sub>x</sub>, NO<sub>x</sub> etc.).
- In an atmosphere containing combustible and volatile gases.
- In a dusty environment.
- Direct sunlight
- Water splashing place.
- Humid place where water condenses.
- In a freezing environment.

If there are possibilities for products to be used under the preceding clause, consult with Murata before actual use.

If static electricity is added to this product, degradation and destruction may be produced.

Please use it after consideration enough so that neither static electricity nor excess voltage is added at the time of an assembly and measurement.

If product malfunctions may result in serious damage, including that to human life, sufficient fail-safe measures must be taken, including the following:

- (1) Installation of protection circuits or other protective device to improve system safety
- (2) Installation of redundant circuits in the case of single-circuit failure

## 7. Input Power Capacity:

Products shall be used in the input power capacity as specified in this specifications.

Inform Murata beforehand, in case that the components are used beyond such input power capacity range .

## 8. Limitation of Applications:

The products are designed and produced for application in ordinary electronic equipment (AV equipment, OA equipment, telecommunication, etc). If the products are to be used in devices requiring extremely high reliability following the application listed below, you should consult with the Murata staff in advance.

- Aircraft equipment.
- Aerospace equipment
- Undersea equipment.
- Power plant control equipment.
- Medical equipment.
- Transportation equipment (vehicles, trains, ships, etc.).
- Automobile equipment which includes the genuine brand of car manufacture, car factory-installed option and dealer-installed option.
- Traffic signal equipment.
- Disaster prevention / crime prevention equipment.
- Data-processing equipment.
- Application which malfunction or operational error may endanger human life and property of assets.
- Application which related to occurrence the serious damage
- Application of similar complexity and/ or reliability requirements to the applications listed in the above.



### Note:

Please make sure that your product has been evaluated and confirmed against your specifications when our product is mounted to your product.

Product specifications are subject to change or our products in it may be discontinued without advance notice.

This catalog is for reference only and not an official product specification document, therefore, please review and approve our official product specification before ordering this product.