



Chipsmall Limited consists of a professional team with an average of over 10 year of expertise in the distribution of electronic components. Based in Hongkong, we have already established firm and mutual-benefit business relationships with customers from,Europe,America and south Asia,supplying obsolete and hard-to-find components to meet their specific needs.

With the principle of “Quality Parts,Customers Priority,Honest Operation,and Considerate Service”,our business mainly focus on the distribution of electronic components. Line cards we deal with include Microchip,ALPS,ROHM,Xilinx,Pulse,ON,Everlight and Freescale. Main products comprise IC,Modules,Potentiometer,IC Socket,Relay,Connector.Our parts cover such applications as commercial,industrial, and automotives areas.

We are looking forward to setting up business relationship with you and hope to provide you with the best service and solution. Let us make a better world for our industry!



Contact us

Tel: +86-755-8981 8866 Fax: +86-755-8427 6832

Email & Skype: info@chipsmall.com Web: www.chipsmall.com

Address: A1208, Overseas Decoration Building, #122 Zhenhua RD., Futian, Shenzhen, China



DESCRIPTION

The LXM1618-12-4x is a Single Output 4W Direct Drive™ CCFL (Cold Cathode Fluorescent Lamp) Inverter Module specifically designed for driving LCD backlight lamps. It is ideal for driving typical 8.4" to 12.1" panels.

The maximum output current is externally programmable over a range of 5 to 6.5mA in 0.5mA steps to allow the inverter to properly match to a wide array of LCD panel lamp current specifications. The modules include a dimming input that permits brightness control from either a DC voltage source, a PWM signal or an external potentiometer.

LXM1618 modules unlike the LXM1617 series does not provide wide range 'burst' mode dimming, rather dimming is provided by amplitude control of the output current waveform, this limits the potential dim range to typically less than 5:1.

For applications not requiring wide range dimming, amplitude control results in lower ripple on the input supply and reduced potential transient noise generation. Many STN type panels are particularly well suited for current amplitude dimming.

The modules convert DC voltage from the system battery or AC adapter directly to high frequency, high-voltage waves required to ignite and operate CCFL lamps. A 5V input inverter is also available (LXM1618-05-4x).

The modules design is based on Microsemi's new LX1689 backlight controller, which provides a number of cost and performance advantages due to the controller's high level of integration.

Other benefits of this new topology are stable fixed-frequency operation, secondary-side strike-voltage regulation and both open and shorted lamp protection with fault timeout.

IMPORTANT: For the most current data, consult MICROSEMI's website: <http://www.microsemi.com>
 Protected By U.S. Patents: 5,923,129; 5,930,121; 6,198,234; Patents Pending

KEY FEATURES

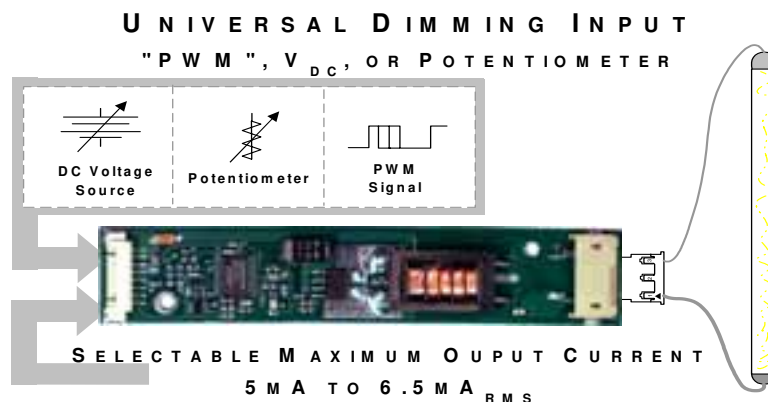
- Externally Programmable Maximum Output Current
- Easy to Use Brightness Control
- Output Short-Circuit Protection and Automatic Strike-Voltage Regulation and Timeout
- Analog Current Amplitude Dimming Method
- Fixed Frequency Operation
- Rated From -20 to 70°C
- UL60950 E175910

APPLICATIONS

- Notebook And Sub-Notebook
- Portable Instrumentation
- Desktop Displays
- Industrial Display Controls

BENEFITS

- Compact, Low Profile Design
- Mates to Wide Variety of LCD Panels
- Output Open Circuit Voltage Regulation Minimizes Corona Discharge For High Reliability

PRODUCT HIGHLIGHT

PACKAGE ORDER INFO

PART NUMBER	OUTPUT CONNECTOR	INVERTER MATES DIRECTLY TO PANEL CONNECTORS
LXM1618-12-41	JST SM02(8.0)B-BHS-1-TB or Yeon Ho 20015WR-05A00	JST BHR-03VS-1
LXM1618-12-42	JST SM02B-BHSS-1-TB or Yeon Ho 35001WR-02A00	JST BHSR-02VS-1
LXM1618-12-43	Honda QZ-19-A3MYL #02	Honda QZ-19-3F01

ABSOLUTE MAXIMUM RATINGS (NOTE 1)

Input Signal Voltage (V_{IN1}).....	-0.3V to 15V
Input Power	5.5W
Output Voltage, no load	Internally Limited to 1600V _{RMS}
Output Current	7.5mA _{RMS} (Internally Limited)
Output Power	4.0W
Input Signal Voltage (SLEEP Input).....	-0.3V to V_{IN1}
Input Signal Voltage (BRITE)	-0.3V to 5.5V
Ambient Operating Temperature, zero airflow.....	-20°C to 70°C
Storage Temperature Range.....	-40°C to 85°C

Note 1: Exceeding these ratings could cause damage to the device. All voltages are with respect to Ground. Currents are positive into, negative out of specified terminal.

RECOMMENDED OPERATING CONDITIONS (R.C.)

This module has been designed to operate over a wide range of input and output conditions. However, best efficiency and performance will be obtained if the module is operated under the condition listed in the 'R.C.' column. Min. and Max. columns indicate values beyond which the inverter, although operational, will not function optimally.

Parameter	Symbol	Recommended Operating Conditions			Units
		Min	R.C.	Max	
Input Supply Voltage Range (Fully Regulated Lamp Current)	V_{IN1}	10.8	12	13.2	V
Input Supply Voltage Range (Functional)		10.2	12	13.8	
Output Power	P_O		3.5	4.0	W
Linear BRITE Control Input Voltage Range ¹	V_{BRT_ADJ}	0.65 to 0.9		2.0	V
Lamp Operating Voltage	V_{LAMP}	465	550	635 ²	V _{RMS}
Lamp Current (Full Brightness)	I_{OLAMP}	5		6.5	mA _{RMS}
Operating Ambient Temperature Range	T_A	-20		70	°C

¹ The minimum V_{BRT_ADJ} voltage depends on the panel characteristics, depending on the panel it can vary from 0.65V to 0.9V

² Total output power must not exceed 4W. Higher voltage lamps may require maximum output current to be set lower than 6.5mA_{RMS}

ELECTRICAL CHARACTERISTICS

Unless otherwise specified, the following specifications apply over the recommended operating condition and ambient temperature of 25°C except where otherwise noted.

Parameter	Symbol	Test Conditions	LXM1618-12-4x			Units
			Min	Typ	Max	
OUTPUT PIN CHARACTERISTICS						
Full Bright Lamp Current	$I_{L(MAX)}$	$V_{BRT_ADJ} \geq 2.0V_{DC}$, $SLEEP \geq 2.0V$, $V_{IN1} = 12V_{DC}$ $I_{SET1} = Ground$, $I_{SET2} = Ground$	4.5	5	5.5	mA _{RMS}
Full Bright Lamp Current	$I_{L(MAX)}$	$V_{BRT_ADJ} \geq 2.0V_{DC}$, $SLEEP \geq 2.0V$, $V_{IN1} = 12V_{DC}$ $I_{SET1} = Ground$, $I_{SET2} = Open$	5.0	5.5	6.0	mA _{RMS}
Full Bright Lamp Current	$I_{L(MAX)}$	$V_{BRT_ADJ} \geq 2.0V_{DC}$, $SLEEP \geq 2.0V$, $V_{IN1} = 12V_{DC}$ $I_{SET1} = Open$, $I_{SET2} = Ground$	5.5	6	6.5	mA _{RMS}
Full Bright Lamp Current	$I_{L(MAX)}$	$V_{BRT_ADJ} \geq 2.0V_{DC}$, $SLEEP \geq 2.0V$, $V_{IN1} = 12V_{DC}$ $I_{SET1} = Open$, $I_{SET2} = Open$	6.0	6.5	7.0	mA _{RMS}
Min. Average Lamp Current	$I_{L(MIN)}$	$V_{BRT_ADJ} = 0.65V_{DC}$, $SLEEP \geq 2.0V$, $V_{IN1} = 12V_{DC}$ $I_{SET1} = I_{SET2} = Ground$		1.5 ³		mA _{RMS}
Lamp Start Voltage	V_{LS}	-20°C < T_A < 70°C, $V_{IN1} > 10.8V_{DC}$	1300	1400		V _{RMS}
Operating Frequency	f_o	$V_{BRT_ADJ} = 2.5V_{DC}$, $SLEEP \geq 2.0V$, $V_{IN1} = 12V$	76	80	83	kHz

³ The inverter is capable of a lower output current than may be recommended by the panel manufacturer. It is the user's responsibility to set the minimum brightness (BRITE) input at or above the panel specification for minimum current.

ELECTRICAL CHARACTERISTICS (CONTINUED)

Unless otherwise specified, the following specifications apply over the recommended operating condition and ambient temperature of 25°C except where otherwise noted.

Parameter	Symbol	Test Conditions	LXM1618-12-4x			Units
			Min	Typ	Max	
BRITE INPUT						
Input Current	I_{BRT}	$V_{BRT_ADJ} = 0V_{DC}$ $V_{BRT_ADJ} = 3V_{DC}$		-300 50		μA_{DC} μA_{DC}
Minimum Input for Max. Lamp Current	V_{BRT_ADJ}	$I_{O(LAMP)} = \text{Maximum Lamp Current}$		2.0	2.05	V_{DC}
Minimum Input for Min. Lamp Current	V_{BRT_ADJ}	$I_{O(LAMP)} = \text{Minimum Lamp Current}$	0.65*			V_{DC}
SLEEP INPUT						
RUN Mode	V_{SLEEP}		2.0		5	V_{DC}
SLEEP Mode	V_{SLEEP}		-0.3		0.8	V_{DC}
SET_{1,2} INPUT						
SET _{1,2} Low Threshold	V_L				0.4	V
Input Current	I_{SET}	$V_{SET} \leq 0.4V$		-300		μA
POWER CHARACTERISTICS						
Sleep Current	$I_{IN(MIN)}$	$V_{IN1} = 12V_{DC}$, $SLEEP \leq 0.8V$	0.0	8	20	μA_{DC}
Run Current	I_{RUN}	$V_{IN1} = 12V_{DC}$, $SLEEP \geq 2.0V$, $I_{SET1} = \text{Open}$ $I_{SET2} = \text{Ground}$, $V_{LAMP} = 550V_{RMS}$		330		mA_{DC}
Efficiency	η	$V_{IN1} = 12V_{DC}$, $SLEEP \geq 2.0V$, $I_{SET1} = \text{Open}$ $I_{SET2} = \text{Ground}$, $V_{LAMP} = 550V_{RMS}$		85		%

* The Inverter is capable of a lower output current than may be recommended by the panel manufacturer. It is the user's responsibility to set the minimum brightness (BRITE) input at or above the panel specification for minimum current. This is likely greater than the 0.65V minimum input.

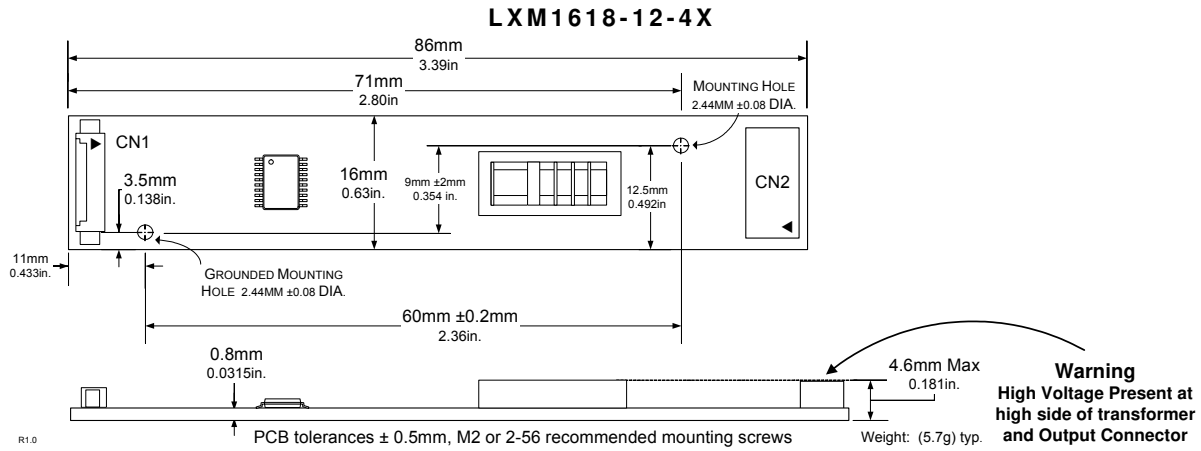
FUNCTIONAL PIN DESCRIPTION

CONN	PIN	DESCRIPTION
CN1 (Molex 53261-0890) Mates with 51021-0800 housing, 50079-8100 pins. Mates with LX9501 input cable assembly		
CN1-1	V_{IN1}	Main Input Power Supply ($10.8V \leq V_{IN1} \leq 13.2V$)
CN1-2		
CN1-3	GND	Power Supply Return
CN1-4		
CN1-5	\overline{SLEEP}	ON/OFF Control. ($0V < \overline{SLEEP} < 0.8 = \text{OFF}$, $\overline{SLEEP} \geq 2.0V = \text{ON}$)
CN1-6	BRITE	Brightness Control ($0.65V$ to $2.0V_{DC}$). $2.0V_{DC}$ gives maximum lamp current.
CN1-7	SET ₁	SET ₁ MSB Connecting this pin to ground decreases the output current (see Table 1)
CN1-8	SET ₂	SET ₂ LSB Connecting this pin to ground decreases the output current (see Table 1)
CN2 for LXM1618-12-41 and -42 (JST SM02(8.0)B-BHS-1-TB Yeon Ho 20015WR-05A00 or SM02B-BHSS-1-TB Yeon Ho 35001WR-02A00)		
CN2-1	V_{HI}	High voltage connection to high Side of lamp. Connect to lamp terminal with shortest lead length. DO NOT connect to Ground.
CN2-2	V_{LO}	Connection to low side of lamp. Connect to lamp terminal with longer lead length. DO NOT connect to Ground
CN2 for LXM1618-12-43 (Honda QZ-19-A3MYL #02)		
CN2-3	V_{HI}	High voltage connection to high side of lamp. Connect to lamp terminal with shortest lead length. DO NOT connect to Ground.
CN2-1	V_{LO}	Connection to low side of lamp. Connect to lamp terminal with longer lead length. DO NOT connect to Ground

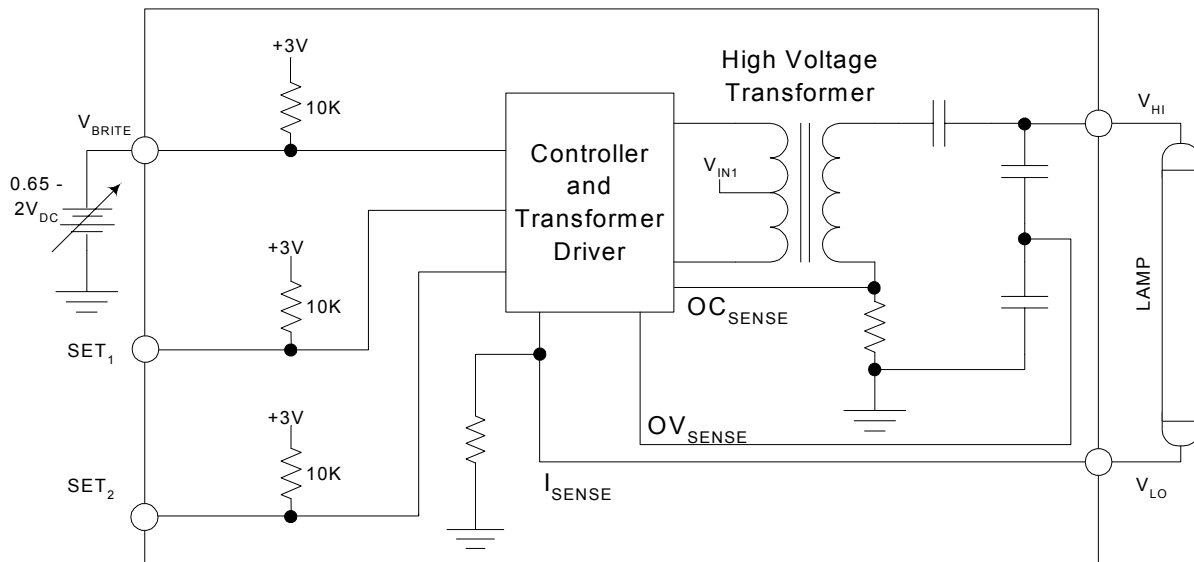
TABLE 1
OUTPUT CURRENT SETTINGS

SET ₁ (Pin 7)	SET ₂ (Pin 8)	Nominal Output Current
Open*	Open*	6.5mA
Open*	Ground	6.0mA
Ground	Open*	5.5mA
Ground	Ground	5.0mA

* If driven by a logic signal it should be open collector or open drain only, not a voltage source.

PHYSICAL DIMENSIONS


All dimensions are in millimeters, inches are for reference.

SIMPLIFIED BLOCK DIAGRAM


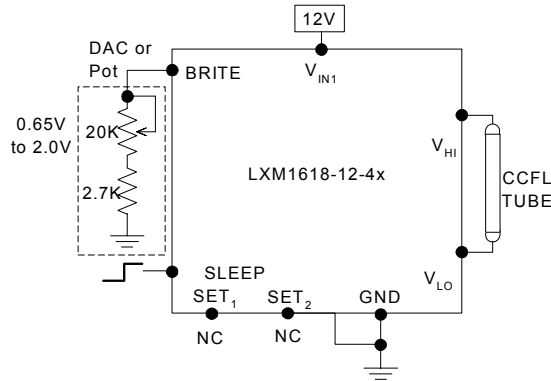
TYPICAL APPLICATION


Figure 1 – Brightness Control
(Output current set to maximum)

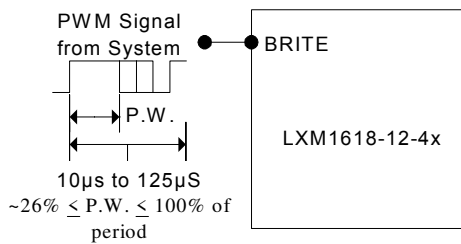
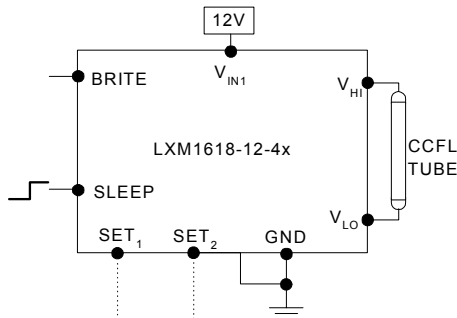


Figure 1A – PWM Brightness Control



L	L	5.0mA _{RMS}
L	H	5.5mA _{RMS}
H	L	6.0mA _{RMS}
H	H	6.5mA _{RMS}

L=GND; H=Open

Figure 2 – Max Output Current
(SET₁ and SET₂ Inputs)

- The brightness control may be a voltage output DAC or other voltage source, a digital pot or 20K manual pot. The inverter contains an internal 10K pull-up to 3V to bias the pot add a 2.7K resistor to set the lower threshold voltage. A 3.3V Logic Level PWM signal from a micro-controller may also be used as shown in Figure 1A.

- If you need to turn the inverter ON/OFF remotely, connect to TTL logic signal to the SLEEP input.

- Connect V_{HI} to high voltage wire from the lamp. Connect V_{LO} to the low voltage wire (wire with thinner insulation). Never connect V_{LO} to circuit ground as this will defeat lamp current regulation. If both lamp wires have heavy high voltage insulation, connect the longest wire to V_{LO}. This wire is typically white.

- Use the SET₁ and SET₂ (see Figure 2) inputs to select the desired maximum output current. Using these two pins in combination allows the inverter to match a wide variety of panels from different manufacturers. Generally the best lamp lifetime and efficiency correlates with driving the CCFL at the manufactures nominal current setting. However the SET₁ and SET₂ inputs allow the user the flexibility to adjust the current to the maximum allowable output current to increase panel brightness at the expense of some reduced lamp life.

- Although the SET pins are designed such that just leaving them open or grounding them is all that is needed to set the output current, they can also be actively set. Using an open collector or open drain logic signal will allow you to reduce the lamp current for situations where greater dim range is required, as an example in nighttime situations. In conjunction with a light sensor or other timer the panel could be set to higher brightness (maximum output current) for daytime illumination and lower brightness (minimum or typical output current) at nighttime. Since the dim ratio is a factor the peak output current, using this technique the effective dim ratio can be increased. Conversely the SET inputs could be used to overdrive the lamp temporarily to facilitate faster lamp warm up at initial lamp turn on. Of course any possible degradation on lamp life from such practices is the users responsibility as not all lamps are designed to be overdriven.

- The inverter has a built in fault timeout function. If the output is open (lamp disconnected or broken) or shorted the inverter will attempt to strike the lamp for several seconds. After about 2 seconds without success the inverter will shutdown. In order to restart the inverter it is necessary to toggle the sleep input or cycle the V_{IN1} input supply

NOTES

PRODUCTION DATA – Information contained in this document is proprietary to Microsemi and is current as of publication date. This document may not be modified in any way without the express written consent of Microsemi. Product processing does not necessarily include testing of all parameters. Microsemi reserves the right to change the configuration and performance of the product and to discontinue product at any time.