



Chipsmall Limited consists of a professional team with an average of over 10 year of expertise in the distribution of electronic components. Based in Hongkong, we have already established firm and mutual-benefit business relationships with customers from,Europe,America and south Asia,supplying obsolete and hard-to-find components to meet their specific needs.

With the principle of “Quality Parts,Customers Priority,Honest Operation,and Considerate Service”,our business mainly focus on the distribution of electronic components. Line cards we deal with include Microchip,ALPS,ROHM,Xilinx,Pulse,ON,Everlight and Freescale. Main products comprise IC,Modules,Potentiometer,IC Socket,Relay,Connector.Our parts cover such applications as commercial,industrial, and automotives areas.

We are looking forward to setting up business relationship with you and hope to provide you with the best service and solution. Let us make a better world for our industry!



Contact us

Tel: +86-755-8981 8866 Fax: +86-755-8427 6832

Email & Skype: info@chipsmall.com Web: www.chipsmall.com

Address: A1208, Overseas Decoration Building, #122 Zhenhua RD., Futian, Shenzhen, China



DESCRIPTION

RangeMAX™ Wide Range Dimming, Dual Output Inverter. The LMX1622 series of Direct Drive CCFL (Cold Cathode Fluorescent Lamp) Inverter Modules are specifically designed for driving two lamp LCD displays. They are available in two power and input voltage ranges.

LMX1622 modules provide the designer with a vastly superior display brightness range. This brightness range is achievable with virtually any LCD display.

RangeMAX Digital Dimming Technique. Digital dimming provides flicker-free brightness control in any wide range (100:1+) dimming application.

The modules are available with a dimming input that permits brightness control from either a DC voltage source or a PWM signal.

The resultant “burst drive” that energizes the lamp was designed specifically to ensure that no premature lamp degradation occurs (See the “How RangeMAX Works” section).

Input Voltage Range. The modules convert the DC voltage from a fixed 12V supply directly to high frequency, high-voltage waves required to ignite and operate CCFL lamps. A 5V input inverter is also available; LXM1612-05 series.

Direct Drive Technology. The modules design is based on a new Direct Drive topology, which provides a number of cost and performance advantages.

Additional Features. Other benefits of this new topology are fixed-frequency operation, secondary-side strike-voltage regulation, and both open and shorted lamp protection. If lamp fails to strike the inverter will timeout and shutdown.

KEY FEATURES

- RangeMAX Wide Range Dimming
- Fixed 5V input
- Easy to Use Brightness Control
- Output Short-Circuit Protection and Automatic Strike-Voltage Regulation and Timeout
- Fixed Frequency Operation
- Microamp SLEEP mode

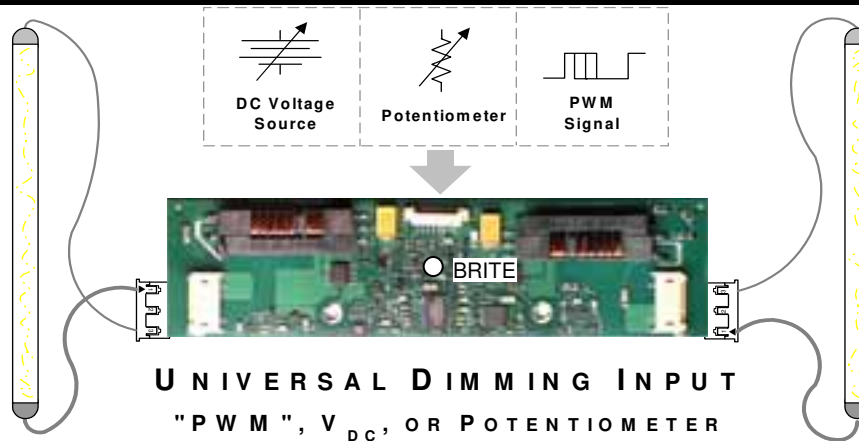
APPLICATIONS

- Notebook Sub-Notebook Computers
- Portable Instrumentation
- Low Ambient Light

BENEFITS

- Smooth, Flicker Free 1-100% Full-Range Brightness Control
- Output Open Circuit Voltage Regulation Minimizes Corona Discharge For High Reliability
- Power Efficient, “Low Brightness” Capability Allows For Advanced Power Management

IMPORTANT: For the most current data, consult MICROSEMI's website: <http://www.microsemi.com>
 Protected By U.S. Patents: 5,923,129; 5,930,121; Patents Pending

PRODUCT HIGHLIGHT

MODULE ORDER INFO

PART NUMBER	LAMP CURRENT	LAMP RUN VOLTAGE	OUTPUT CONNECTOR	INVERTER MATES DIRECTLY TO PANEL CONNECTORS
LXM1622-12-01	6.5mA	500-750	JST SM02(8.0)B-BHS-1-TB or Yeon Ho 20015WR-05A00	BHR-03VS-1
LXM1622-12-02	5.5mA	350-550		
LXM1622-12-03	5.5mA	350-550	Honda QZ-19-A3MYL #02	QZ-19-3F01

ABSOLUTE MAXIMUM RATINGS(NOTE 1)

Input Supply Voltage (V _{IN}).....	-0.3V to 16V
Output Voltage, no load.....	Internally Limited to 1800V _{RMS}
Output Current	7.5mA _{RMS} (Internally Limited)
Output Power (for 2 lamps)	12W
Input Signal Voltage (BRITE , V _{SYNC} Input)	-0.3V to +6.5V
Input Signal Voltage (SLEEP)	-0.3V to V _{IN} +0.5V
Ambient Operating Temperature, zero airflow.....	0°C to 70°C
Storage Temperature Range.....	-40°C to 85°C

Note 1: Exceeding these ratings could cause damage to the device. All voltages are with respect to Ground. Currents are positive into, negative out of specified terminal.

RECOMMENDED OPERATING CONDITIONS

This module has been designed to operate over a wide range of input and output conditions. However, best efficiency and performance will be obtained if the module is operated under the condition listed in the 'R.C.' Column. Min. and Max. columns indicate values beyond which the inverter, although operational, will not function optimally.

Parameter	Symbol	Recommended Operating Conditions			Units
		Min	R.C.	Max	
V _{IN} Voltage Range	V _{IN}	10.8	12.0	13.2	V
Output Power (-01)	P _O	5.8	8	10.8	W
Output Power (-02,-03)	P _O	3	5	6	W
Brightness Control Input Voltage Range	V _{BRT ADJ}	0.0		2.5	V
Lamp Operating Voltage (-01)	V _{LAMP}	500	625	750	V _{RMS}
Lamp Operating Voltage (-02,-03)	V _{LAMP}	300	425	500	V _{RMS}
Lamp Current Full Brightness (-01)	I _{OLAMP}		6.5		mA _{RMS}
Lamp Current Full Brightness (-02,-03)	I _{OLAMP}		5.5		mA _{RMS}
Operating Ambient Temperature Range	T _A	0		70	°C

ELECTRICAL CHARACTERISTICS

Unless otherwise specified, these specifications apply over the recommended operating conditions and 25°C ambient temperature for the LXM1622-12-xx.

Parameter	Symbol	Test Conditions	LXM1622-12-xx			Units
			Min	Typ	Max	
▶ OUTPUT PIN CHARACTERISTICS						
Full Bright Lamp Current (-01)	I _{L(MAX)}	V _{BRT ADJ} = 2.25V	5.85	6.5	7.15	mA _{RMS}
Full Bright Lamp Current (-02,-03)	I _{L(MAX)}	V _{BRT ADJ} = 2.25V	4.95	5.5	6.05	mA _{RMS}
Min. Average Lamp Current (Note 2)	I _{L(MIN)}	V _{BRT ADJ} = 0V _{DC}		.25		mA _{RMS}
Lamp Start Voltage	V _{LS}		1350	1500	1800	V _{RMS}
Operating Frequency	F _O	V _{BRT ADJ} = 2.25VDC	66	76	86	KHz
Fault Timeout	T _{FAULT}			1.6		SEC
▶ BRITE INPUT						
Linear Dim Control Range	V _{BRT}		.25		2.2	V _{DC}
Input Current	I _{BRT}	V _{BRT ADJ} = 0V _{DC}	-680	-710	-730	μA _{DC}
		V _{BRT ADJ} = 2.5V _{DC}	196	203	220	μA _{DC}
Input Voltage for Max. Lamp Current	V _{BRT ADJ}	I _{O(LAMP)} = 100% Duty Cycle	2.25		2.5	V _{DC}
Input Voltage for Min. Lamp Current	V _{BRT ADJ}	I _{O(LAMP)} = Minimum Duty Cycle	0		0.25	V _{DC}
▶ SLEEP INPUT						
RUN Mode	V _{SLEEP}	V _{IN} =12V	1.5			V _{DC}
OFF Mode	V _{SLEEP}	V _{IN} =12V	-0.3		0.8	V _{DC}
Input Current	I _{SLEEP}	SLEEP = 5.0V	400	425	450	μA
		SLEEP = 0.0V		0		
▶ VSYNC CHARACTERISTICS						
Logic High Level	V _{SYNC (HI)}	V _{IN} =12V	1.5			V _{DC}
Logic Low Level	V _{SYNC (LO)}	V _{IN} =12V	0		0.8	V _{DC}
Input Impedance	Z _{IN}			27		KΩ
Input Frequency	FV _{SYNC}		50		150	Hz
Free Run Frequency	F _{BURST}	Output Burst Rate; V _{SYNC} =0V	190	250	310	Hz

ELECTRICAL CHARACTERISTICS (CONTINUED)

Unless otherwise specified, these specifications apply over the recommended operating conditions and 25°C ambient temperature for the LXM1622-12-xx.

Parameter	Symbol	Test Conditions	LXM1622-12-xx			Units
			Min	Typ	Max	
POWER CHARACTERISTICS						
Run Current (LXM1622-12-01)	I _{RUN}	V _{IN} =12V, V _{BRT ADJ} = 2.25V, V _{LAMP} = 625V _{RMS}		800		mA
Run Current (LXM1622-12-02,03)	I _{RUN}	V _{IN} =12V, V _{BRT ADJ} = 2.25V, V _{LAMP} = 425V _{RMS}		450		mA
Sleep Current	I _{SLEEP}	V _{IN} = 12V, SLEEP = 0.0V	0.0	0.5	10	µA

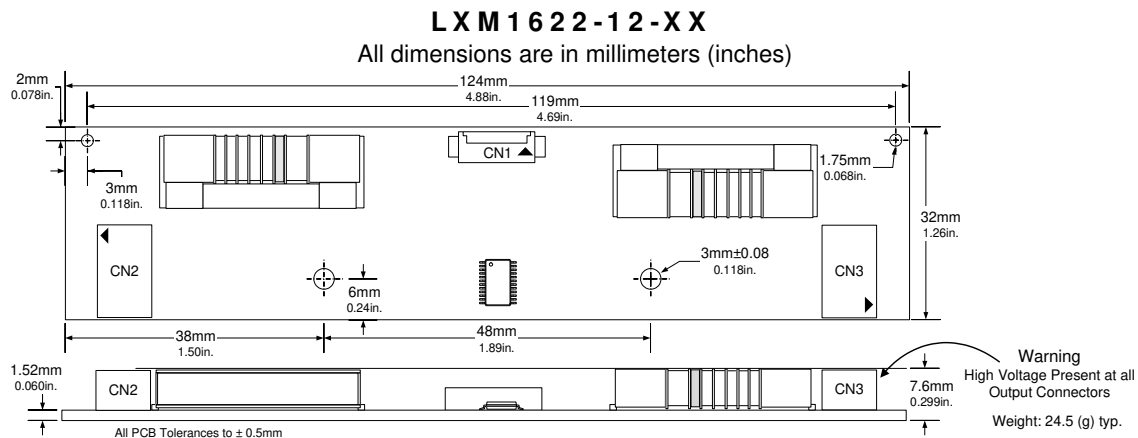
Note 2: Minimum lamp current required to maintain even light output may vary with display panel.
Average RMS current = (burst duty cycle) X (burst amplitude of full lamp current)

FUNCTIONAL PIN DESCRIPTION

Conn.	Pin	Description
CN1 (Molex 53261-0890) *		
CN1-1,2	V _{IN}	Main Input Power Supply (10.8V to 13.2V)
CN1-3,4	GND	Power Supply Return
CN1-5	SLEEP	>1.5V(Backlight on), <0.8V (backlight off), I _{SLEEP} =425uA @ 5.0V, disabled if left open
CN1-6	BRITE	Brightness Control (0.25- 2.2VDC) 2.25VDC gives maximum lamp current
CN1-7	BRITE RTN	Signal Ground (0Vdc)
CN1-8	V _{SYNC}	Vertical Synchronization Input (50 < f _{SYNC} > 150Hz), minimum pulse width 10uS
CN2,3 for LXM1622-12-01, 02 (JST SM02(8.0)B-BHS-1-TB or Yeon Ho 20015WR-05A00)		
CN2-1	V _{HI}	High Voltage Connection to High Side of Lamp. Connect to lamp terminal with shortest lead length. DO NOT connect to Ground.
CN2-2	V _{LO}	Connection to Low Side of Lamp. Connect to lamp terminal with longer lead length. DO NOT connect to Ground.
CN2,3 for LXM1622-12-03 (Honda QZ-19-A3MYL#02)		
CN2-3	V _{HI}	High Voltage Connection to High Side of Lamp. Connect to lamp terminal with shortest lead length. DO NOT connect to Ground.
CN2-1	V _{LO}	Connection to Lower Side of Lamp. Connect to lamp terminal with longer lead length. DO NOT connect to Ground.

* LX9501 Mating Connector Assembly Available

PHYSICAL DIMENSIONS



HOW THE RANGEMAX WORKS

LAMP VOLTAGE & LAMP CURRENT – BURST MODE OPERATION

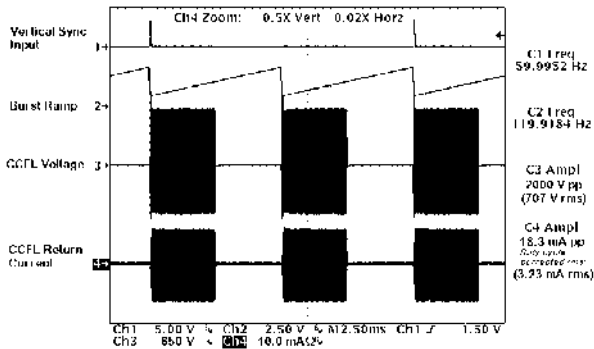


Figure 1 – 50% Burst Duty Cycle

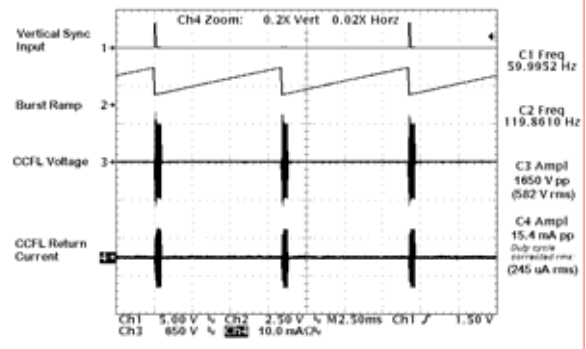


Figure 2 – 5% Burst Duty Cycle

Rather than using the traditional dimming technique of varying lamp current magnitude to adjust light output, RangeMAX inverters use a fixed lamp current value with a duty cycle control method.

The lamp current burst width can be modulated from 100% (continuous lamp current) down to a 5% duty cycle, allowing the lamp to be dimmed to less than 3% of its full brightness.

As can be seen in Trace 4 of Figure 3 photo at right, careful design consideration was given to controlling lamp start voltage to softly start current flow. This eliminates current overshoot that can result in premature cathode wear and reduce lamp life.

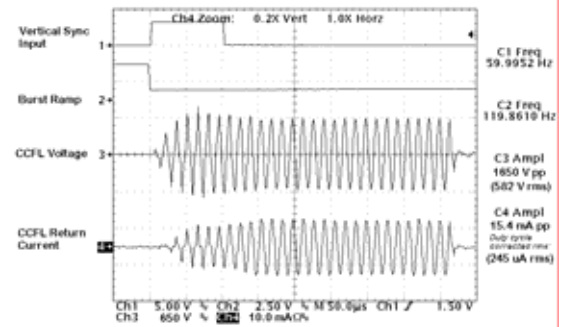


Figure 3 – 5% Burst Duty Cycle (Expanded Time Base)

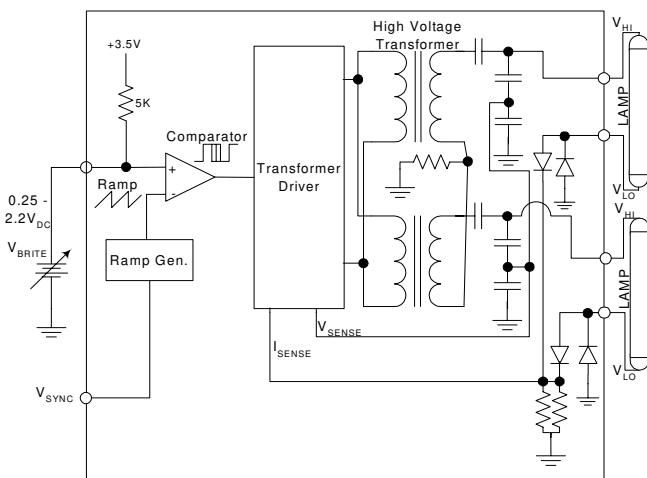


Figure 4 – RangeMAX Simplified Block Diagram

HIGHLIGHTS

- Integrated brightness control circuit includes a DC voltage to pulse width converter that minimizes system design work and system noise susceptibility. This provides a familiar and convenient interface while reducing the potential for externally induced noise, which can cause lamp flicker.
- RangeMAX inverter modules are designed to operate with the burst frequency synchronized to the video frame rate. This provides operation with no visible display disturbances caused by beat frequencies between the lamps and video frame rates. In this synchronous mode, the inverter burst rate operates at twice the video refresh rate, well beyond standard 50/60Hz video refresh rates where the eye can perceive pulsing light.

HOW THE RANGEMAX WORKS (CONTINUED)
HIGHLIGHTS (CONTINUED)

- In applications with no access to a vertical sync, an onboard oscillator operates the inverter burst rate at about 270Hz. In this non-synchronous mode, minor display disturbances can be found under certain video conditions. This performance may be acceptable for many applications, but synchronization must be used when no disturbance can be tolerated.
- Separate feedback loops for lamp current and open circuit voltage regulation insure reliable strike under all operating conditions, automatic over-voltage prevention with broken or failed lamps, and accurate lamp current regulation.
- A single input will accommodate negative and positive vertical sync pulses at any pulse width.

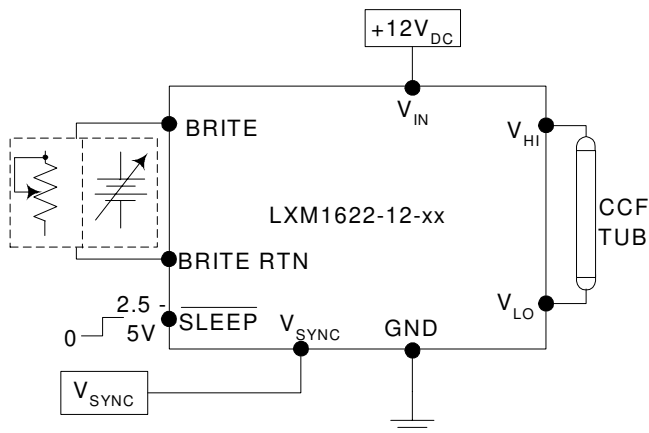
TYPICAL APPLICATION


Figure 5 - Brightness Control

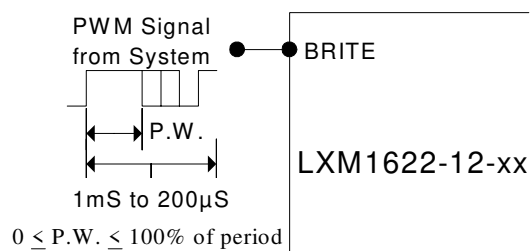


Figure 5A - PWM Brightness Control

- The Brightness control may be a voltage output DAC, digital resistor or a simple 10K potentiometer, or other voltage source, as shown in Figure 5. A 2.5V to 5V Logic Level PWM signal from a micro-controller may also be used as shown in Figure 5A.
- If synchronization to the video frame rate is desired, connect the vertical sync pulse from the system video controller to the V_{SYNC} input. If no video synchronization is desired, connect V_{SYNC} to ground.
- If you need to turn the inverter ON/OFF remotely, connect a 2.5V to 5V logic signal to the \overline{SLEEP} input. If remote ON/OFF is not needed, connect the \overline{SLEEP} input to V_{IN} or other voltage source between 2.5V and 5V.
- Connect V_{HI} to high voltage wire from the lamp. Connect V_{LO} to the low voltage wire (wire with thinner insulation). Never connect V_{LO} to circuit ground as this will defeat lamp current regulation. If both lamp wires have heavy high voltage insulation, connect the longest wire to V_{LO} . This wire is typically white.

RangeMAX INVERTERS

Also available in single lamp inverters LXM1612-xx-xx, 5V dual LXM1622-05-xx and Quad Output LXM1641-01 versions for multiple lamp applications.

LMX1622-12-XX OUTPUT CURRENT ADJUST

The LMX1622-12-01 output current can be adjusted lower by changing the value of one resistor (R18) on the PCB. The following table shows the new output current values:

Add R18

Output Current	Resistor Value
6.5mArms	Not used
6.0mArms	1.0M 5%
5.5mArms	422K 1%
5.0mArms	267K 1%
4.5mArms	178K 1%
4.0mArms	121K 1%
3.5mArms	88.7K 1%
3.0mArms	68.1K 1%

The LMX1622-12-02,03 output current can be adjusted lower by changing the value of one resistor (R18) on the PCB. Changing the value of R35 can also increase the output current. The following table shows the new output current values:

Add R18

Output Current	Resistor Value
5.5mArms	Not used
5.0mArms	845K 1%,
4.5mArms	374K 1%,
4.0mArms	232K 1%
3.5mArms	127K 1%,
3.0mArms	71.5K 1%

Change R35

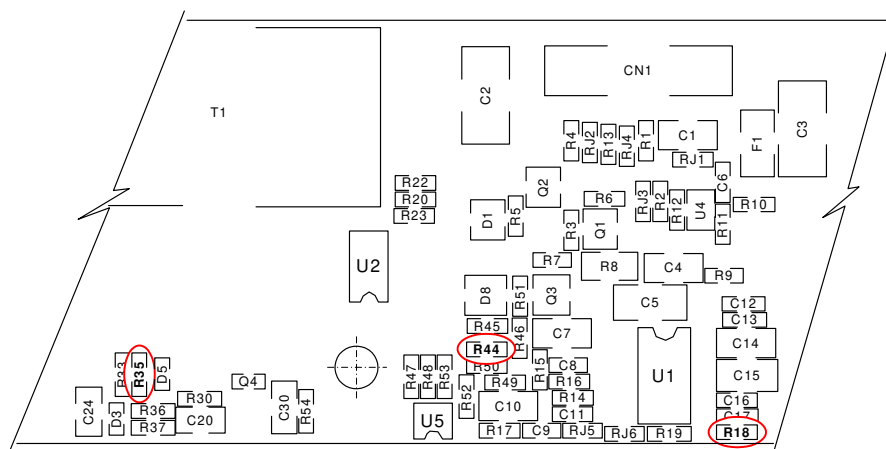
Output Current	Resistor Value
5.5mArms	576 1% (stock value)
6.0mArms	499 1%
6.5mArms	442 1%

DRIVING THE BRITE INPUT FROM A HIGH IMPEADANCE

The LMX1622-12-xx comes with a built in 5K pull-up resistor to allow the use of an external potentiometer for brightness adjust. In some cases this pull-up resistor may interfere with those driving the BRITE

input from a high impedance. In this case the internal pull-up resistor R44 may be removed from the board. Please use the drawing below to help locate the specified resistor.

COMPONENT DRAWING





Not recommended for new design

RangeMAX™

LXM1622-12-xx

DUAL 5W, DIGITAL DIMMING CCFL INVERTER MODULE

PRODUCTION DATA SHEET

NOTES

Preliminary Data – Information contained in this document is pre-production data and is proprietary to LinFinity. It may not be modified in any way without the express written consent of LinFinity. Product referred to herein is offered in sample form only and LinFinity reserves the right to change or discontinue this proposed product at any time.