



Chipsmall Limited consists of a professional team with an average of over 10 year of expertise in the distribution of electronic components. Based in Hongkong, we have already established firm and mutual-benefit business relationships with customers from,Europe,America and south Asia,supplying obsolete and hard-to-find components to meet their specific needs.

With the principle of “Quality Parts,Customers Priority,Honest Operation,and Considerate Service”,our business mainly focus on the distribution of electronic components. Line cards we deal with include Microchip,ALPS,ROHM,Xilinx,Pulse,ON,Everlight and Freescale. Main products comprise IC,Modules,Potentiometer,IC Socket,Relay,Connector.Our parts cover such applications as commercial,industrial, and automotives areas.

We are looking forward to setting up business relationship with you and hope to provide you with the best service and solution. Let us make a better world for our industry!



## Contact us

Tel: +86-755-8981 8866 Fax: +86-755-8427 6832

Email & Skype: info@chipsmall.com Web: www.chipsmall.com

Address: A1208, Overseas Decoration Building, #122 Zhenhua RD., Futian, Shenzhen, China



**DESCRIPTION**

The LXMG1627-05-6x is a Dual 6W Output Direct Drive<sup>TM</sup> CCFL (Cold Cathode Fluorescent Lamp) Inverter Module specifically designed for driving LCD backlight lamps. It is ideal for driving typical 10.4" to 15" TFT panels.

LXMG1627 modules provide the designer with a vastly superior display brightness range. This brightness range is achievable with virtually any LCD display.

The modules are available with a dimming input that permits brightness control from either a DC voltage source or a PWM signal or external potentiometer. The maximum output current is externally programmable over a range of 5mA to 8mA in 1mA steps to allow the inverter to properly match to a wide array of LCD panel lamp current specifications.

RangeMAX<sup>TM</sup> Digital Dimming Technique provides flicker-free brightness control in any wide range typically (50:1+) dimming application.

The resultant "burst drive" that energizes the lamp was designed specifically to ensure that no premature lamp degradation occurs, while allowing significant power savings at lower dim levels.

The modules convert DC voltage from the system battery or AC adapter directly to high frequency, high-voltage waves required to ignite and operate CCFL lamps. A 12V input inverter is also available (LXMG1627-12-6x), as well as 4W versions (LXMG1627-xx-4x) for driving smaller lower voltage/power panels.

The module's design is based on Microsemi's LX6512 backlight controller, which provides a number of cost and performance advantages due to the controller's high level of integration.

Other benefits of this new topology are stable fixed-frequency operation, secondary-side strike-voltage regulation and both open and short protection with fault timeout.

**KEY FEATURES**

- Externally Programmable Maximum Output Current
- Easy to Use Brightness Control
- RangeMAX<sup>TM</sup> Wide Range Dimming
- Output Open/Short-Circuit Protection and Automatic Strike-Voltage Regulation and Timeout
- Fixed Frequency Operation
- Rated From -30°C to 80°C
- UL60950 E175910 Pending
- RoHS Compliant

**APPLICATIONS**

- High Brightness Displays
- Portable Instrumentation
- Desktop Displays
- Industrial Display Controls

**BENEFITS**

- Smooth, Flicker Free 2%-100% Full-Range Brightness Control
- Programmable Output Current Allows Inverter To Mate With A Wide Variety Of LCD Panel's Specifications
- Output Open Circuit Voltage Regulation Minimizes Corona Discharge For High Reliability

**IMPORTANT:** For the most current data, consult MICROSEMI's website: <http://www.microsemi.com>  
Protected By U.S. Patents: 5,923,129; 5,930,121; 6,198,234; Patents Pending

**PRODUCT HIGHLIGHT**

**UNIVERSAL DIMMING INPUT**  
"PWM", V<sub>DC</sub>, or POTENTIOMETER

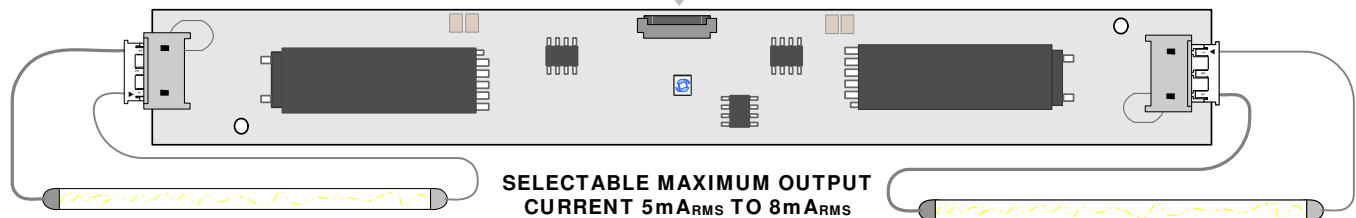
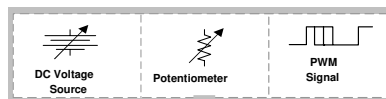
**PACKAGE ORDER INFO**

PART NUMBER	OUTPUT CONNECTOR	INVERTER MATES DIRECTLY TO PANEL CONNECTORS
LXMG1627-05-61	JST SM02(8.0)B-BHS-1-TB(LF)(SN) or Yeon Ho 20015WR-05A00	JST BHR-03VS-1
LXMG1627-05-62	JST SM02B-BHSS-1-TB(LF)(SN) or Yeon Ho 35001WR-02A00	JST BHSR-02VS-1



**ABSOLUTE MAXIMUM RATINGS**

Input Signal Voltage ( $V_{IN}$ ).....	-0.3V to 6V
Input Power.....	15W
Output Voltage, no load.....	Internally Limited to 1800V <sub>RMS</sub>
Output Current.....	9.5mA <sub>RMS</sub> (Internally Limited)
Output Power (each output).....	6.0W
Input Signal Voltage (SLEEP Input).....	-0.3V to $V_{IN}$
Input Signal Voltage (BRITE).....	-0.3V to 5.5V
Ambient Operating Temperature, zero airflow.....	-30°C to 80°C
Operating Relative Humidity, non-condensing.....	≤90%
Storage Temperature Range.....	-40°C to 85°C

Exceeding these ratings could cause damage to the device. All voltages are with respect to Ground. Currents are positive into, negative out of specified terminal.

**RECOMMENDED OPERATING CONDITIONS (R.C.)**

This module has been designed to operate over a wide range of input and output conditions. However, best efficiency and performance will be obtained if the module is operated under the condition listed in the 'R.C.' column. Min. and Max. columns indicate values beyond which the inverter, although operational, may not function optimally.

Parameter	Symbol	Recommended Operating Conditions			Units
		Min	R.C.	Max	
Input Supply Voltage Range	$V_{IN}$	4.75	5	5.25	V
Output Power (each output)	$P_O$		5.5	6.0	W
Linear BRITE Control Input Voltage Range	$V_{BRT\_ADJ}$	0		2.5	V
Lamp Operating Voltage	$V_{LAMP}$	480	600	720	V <sub>RMS</sub>
Lamp Current (Full Brightness)	$I_{OLAMP}$	5		8	mA <sub>RMS</sub>
Operating Ambient Temperature Range	$T_A$	-30		80	°C

**ELECTRICAL CHARACTERISTICS**

Unless otherwise specified, the following specifications apply over the recommended operating condition and ambient temperature of 0°C to 60°C except where otherwise noted; BRITE ≥ 2.5V, SLEEP ≥ 2.1V,  $V_{IN}$  = 5V.

Parameter	Symbol	Test Conditions	LXMG1627-05-6x			Units
			Min	Typ	Max	
<b>OUTPUT PIN CHARACTERISTICS</b>						
Full Bright Lamp Current (each output)	$I_{L(MAX)}$	SET <sub>1</sub> = Ground, SET <sub>2</sub> = Ground	4.4	5.0	5.6	mA <sub>RMS</sub>
Full Bright Lamp Current (each output)	$I_{L(MAX)}$	SET <sub>1</sub> = Ground, SET <sub>2</sub> = Open	5.4	6.0	6.6	mA <sub>RMS</sub>
Full Bright Lamp Current (each output)	$I_{L(MAX)}$	SET <sub>1</sub> = Open, SET <sub>2</sub> = Ground	6.4	7.0	7.6	mA <sub>RMS</sub>
Full Bright Lamp Current (each output)	$I_{L(MAX)}$	SET <sub>1</sub> = Open, SET <sub>2</sub> = Open	7.4	8.0	8.6	mA <sub>RMS</sub>
Output Current Lamp to Lamp Deviation	$I_{LL\%DEV}$	SET <sub>1</sub> = Open, SET <sub>2</sub> = Open		2	10	%
Min. Average Lamp Current (each output)	$I_{L(MIN)}$	BRITE = 0V SET <sub>1</sub> = SET <sub>2</sub> = Ground $I_{L(MIN)} = I_{LMAX} * \sqrt{\text{Burst Duty Cycle}}$		1.0		mA <sub>RMS</sub>
Lamp Start Voltage	$V_{LS}$	-30°C < $T_A$ < 80°C, $V_{IN}$ > 4.75V	1500	1650		V <sub>RMS</sub>
Operating Frequency	$f_O$		45	53	60	kHz
Burst Frequency	$f_{BURST}$	Output Burst Frequency	180	200	240	Hz

**ELECTRICAL CHARACTERISTICS (CONTINUED)**

Unless otherwise specified, the following specifications apply over the recommended operating condition and ambient temperature of 0°C to 60°C except where otherwise noted; BRITE ≥ 2.5V, SLEEP ≥ 2.1V, V<sub>IN</sub> = 5V

Parameter	Symbol	Test Conditions	LXMG1627-05-6x			Units
			Min	Typ	Max	
<b>▶ BRITE INPUT</b>						
Input Current	I <sub>BRT</sub>	BRITE = 0V		-13.4		μA
		BRITE = 3V		-5		μA
Minimum Input for Max. Lamp Current	V <sub>BRT_ADJ</sub>	I <sub>O(LAMP)</sub> = Maximum Lamp Current	2.1	2.3	2.5	V
Maximum Input for Min. Lamp Current	V <sub>BRT_ADJ</sub>	I <sub>O(LAMP)</sub> = Minimum Lamp Current	0			V
<b>▶ SLEEP INPUT</b>						
RUN Mode	V <sub>SLEEP</sub>		2.1		V <sub>IN</sub>	V
SLEEP Mode	V <sub>SLEEP</sub>		0		0.8	V
<b>▶ SET<sub>1,2</sub> INPUT</b>						
SET <sub>1,2</sub> Low Threshold	V <sub>L</sub>		0		0.4	V
Input Current	I <sub>SET</sub>	SET <sub>x</sub> = 0V		-90		μA
<b>▶ POWER CHARACTERISTICS</b>						
Sleep Current	I <sub>IN(MIN)</sub>	SLEEP ≤ 0.8V		5	20	μA
Run Current	I <sub>IN(RUN)</sub>	SET <sub>1</sub> = Open, SET <sub>2</sub> = Ground, V <sub>LAMP</sub> = 600V <sub>RMS</sub>		2240		mA
Strike (Open Lamps)	T <sub>S_DWELL</sub>		1.0	1.5		Sec
Supply Current After Fault Timeout	I <sub>FAULT</sub>	Fault Timeout		7		mA
Efficiency	η	SET <sub>1</sub> = Open, SET <sub>2</sub> = Ground, V <sub>LAMP</sub> = 600V <sub>RMS</sub>		75		%

**FUNCTIONAL PIN DESCRIPTION**

CONN	PIN	DESCRIPTION
<b>CN1 (Molex 53261-0871) Mates with 51021-0800 housing, 50079-8100 pins. Mates with LX9501G input cable assembly</b>		
CN1-1	V <sub>IN</sub>	Main Input Power Supply (4.75V ≤ V <sub>IN</sub> ≤ 5.25V)
CN1-2		
CN1-3	GND	Power Supply Return
CN1-4		
CN1-5	SLEEP	ON/OFF Control. (0V ≤ SLEEP ≤ 0.8 = OFF, SLEEP ≥ 2.1V = ON)
CN1-6	BRITE	Brightness Control (0V to 2.5V). 2.5V gives maximum lamp current; 500k manual pot; PWM signal.
CN1-7	SET <sub>1</sub>	SET <sub>1</sub> MSB Connecting this pin to ground decreases the output current (see Table 1)
CN1-8	SET <sub>2</sub>	SET <sub>2</sub> LSB Connecting this pin to ground decreases the output current (see Table 1)
<b>CN2, CN3 for LXMG1627-05-61 and -62</b> (JST SM02(8.0)B-BHS-1-TB(LF)(SN)   Yeon Ho 20015WR-05A00 or SM02B-BHSS-1-TB(LF)(SN)   Yeon Ho 35001WR-02A00)		
CN2-1 CN3-1	V <sub>HI</sub>	High voltage connection to high side of lamp. Connect to lamp terminal with shortest lead length. <b>DO NOT</b> connect to Ground.
CN2-2 CN3-2	V <sub>LO</sub>	Connection to low side of lamp. Connect to lamp terminal with longer lead length. <b>DO NOT</b> connect to Ground

**TABLE 1**
**OUTPUT CURRENT SETTINGS**

SET <sub>1</sub> (Pin 7)	SET <sub>2</sub> (Pin 8)	Nominal Output Current
Open*	Open*	8.0mA
Open*	Ground	7.0mA
Ground	Open*	6.0mA
Ground	Ground	5.0mA

\* If driven by a logic signal it should be open collector or open drain only, not a voltage source.

**PHYSICAL DIMENSIONS**
**LXMG1627-05-6x**

GROUNDING MOUNTING HOLE 3.18MM ±0.08 DIA. (0.121 IN)  
6MM HEAD CLEARANCE BOTH HOLES

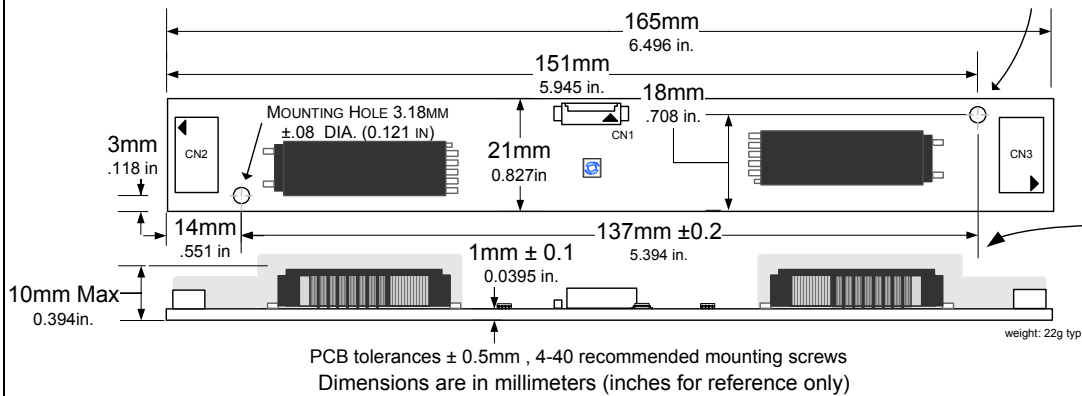

**Warning**  
High Voltage is present at high side of each transformer, its core and the high side of the output connector pins, please provide at least 3 mm clearance (in all directions) on the board to any conductor when mounting

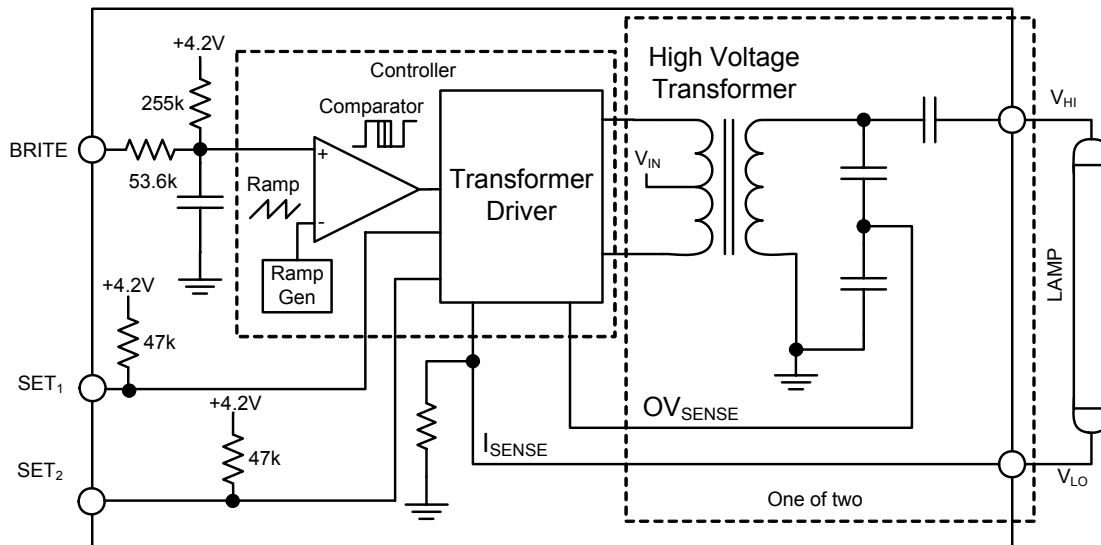
**SIMPLIFIED BLOCK DIAGRAM**

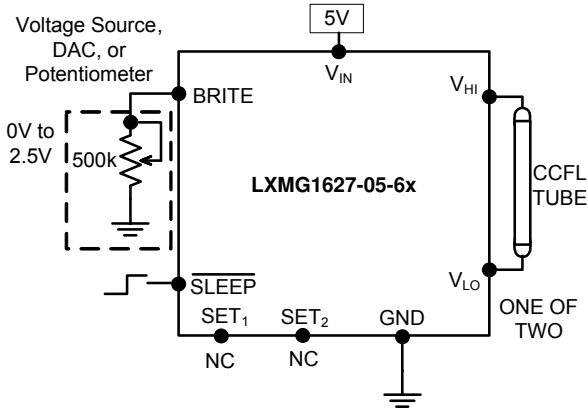
**TYPICAL APPLICATION**

**Figure 1 – Brightness Control**  
(Output current set to maximum)

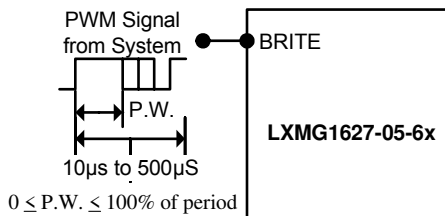

**Figure 1A – PWM Brightness Control**

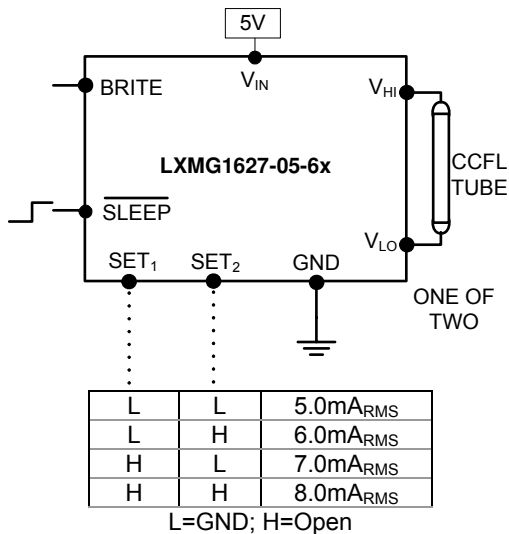

**Figure 2 – Maximum Output Current**  
(SET<sub>1</sub> and SET<sub>2</sub> Inputs)

- The brightness control may be a voltage output DAC or other voltage source, a digital pot or 500k manual pot. The inverter contains an internal 309k pull-up to typically 4.2V to bias the pot. A PWM logic level signal (figure 1A) may be used up to 5V; however the inverter will reach maximum current at less than 100% duty cycle. This can be calculated as approximately 2.3V divided by the logic high voltage level; with 3.3V logic level this corresponds to about 70% duty cycle for maximum lamp current.
- If you need to turn the inverter ON/OFF remotely, connect to TTL logic signal to the SLEEP input.
- Connect V<sub>HI</sub> to high voltage wire from the lamp. Connect V<sub>LO</sub> to the low voltage wire (wire with thinner insulation). Never connect V<sub>LO</sub> to circuit ground as this will defeat lamp current regulation. If both lamp wires have heavy high voltage insulation, connect the longest wire to V<sub>LO</sub>. This wire is typically white.
- Use the SET<sub>1</sub> and SET<sub>2</sub> (see Figure 2) inputs to select the desired maximum output current. Using these two pins in combination allows the inverter to match a wide variety of panels from different manufacturers. Generally the best lamp lifetime correlates with driving the CCFL at the manufacturer's nominal current setting. However the SET<sub>1</sub> and SET<sub>2</sub> inputs allow the user the flexibility to adjust the current to the maximum allowable output current to increase panel brightness at the expense of some reduced lamp life.
- Although the SET pins are designed such that just leaving them open or grounding them is all that is needed to set the output current, they can also be actively set. Using an open collector or open drain logic signal will allow you to reduce the lamp current for situations where greater dim range is required, as an example in nighttime situations. Since the dim ratio is a factor of both the burst duty cycle and the peak output current, using this technique the effective dim ratio can be increased greater than the burst duty cycle alone. Conversely the SET inputs could be used to overdrive the lamp temporarily to facilitate faster lamp warm up at initial lamp turn on. Of course any possible degradation on lamp life from such practices is the users responsibility since not all lamps are designed to be overdriven.
- The inverter has a built in fault timeout function. If either or both outputs are open (lamp disconnected or broken) the inverter will attempt to strike for about a 1.5 seconds and then shutdown for safety purposes. In order to restart the inverter it is necessary to toggle the sleep input or cycle the V<sub>IN</sub> input supply.



PanelMatch™

LXMG1627-05-6x

5V Dual 6W Programmable CCFL Inverter Module

PRODUCTION DATASHEET

NOTES

PRODUCTION DATA – Information contained in this document is proprietary to Microsemi and is current as of publication date. This document may not be modified in any way without the express written consent of Microsemi. Product processing does not necessarily include testing of all parameters. Microsemi reserves the right to change the configuration and performance of the product and to discontinue product at any time.