



Chipsmall Limited consists of a professional team with an average of over 10 year of expertise in the distribution of electronic components. Based in Hongkong, we have already established firm and mutual-benefit business relationships with customers from,Europe,America and south Asia,supplying obsolete and hard-to-find components to meet their specific needs.

With the principle of “Quality Parts,Customers Priority,Honest Operation,and Considerate Service”,our business mainly focus on the distribution of electronic components. Line cards we deal with include Microchip,ALPS,ROHM,Xilinx,Pulse,ON,Everlight and Freescale. Main products comprise IC,Modules,Potentiometer,IC Socket,Relay,Connector.Our parts cover such applications as commercial,industrial, and automotives areas.

We are looking forward to setting up business relationship with you and hope to provide you with the best service and solution. Let us make a better world for our industry!



Contact us

Tel: +86-755-8981 8866 Fax: +86-755-8427 6832

Email & Skype: info@chipsmall.com Web: www.chipsmall.com

Address: A1208, Overseas Decoration Building, #122 Zhenhua RD., Futian, Shenzhen, China



Studio White LED Emitter

LZ4-00SW08



Key Features

- 4-die Studio White (5300K) LED
- CCT and color rendering matched to HID arc lamp
- CRI85 minimum / R9 50 typical
- Up to 10 Watt power dissipation on compact 7.0mm x 7.0mm footprint
- Low Thermal Resistance (2.8°C/W)
- Engineered ceramic package with integrated glass lens
- JEDEC Level 1 for Moisture Sensitivity Level
- Autoclave compliant (JEDEC JESD22-A102-C)
- Lead (Pb) free and RoHS compliant
- Reflow solderable (up to 6 cycles)
- Emitter available on Standard or Serially connected MCPCB (optional)
- Full suite of TIR secondary optics family available

Typical Applications

- Studio Lighting
- Photography Lighting
- High-end retail Lighting
- Showrooms Lighting

Description

The LZ4-00SW08 Studio White LED emitter features CCT and color rendering matched to HID arc lamps used in studio lighting. It delivers a daylight color temperature of 5300K, CRI greater than 85 and R9 red content of 50, resulting in a natural color rendering of skin tones and other colors, which cannot be obtained by standard daylight white LED emitters. The emitter, based on LED Engin's LuxiGen technology platform, may be driven up to 10W of power in a compact 7.0mmx7.0mm footprint. The emitter's low thermal resistance allows users to drive the emitter with high current, while keeping the junction temperature low to ensure long operating life.

Part number options

Base part number

| Part number | Description |
|-----------------|---|
| LZ4-00SW08-xxxx | LZ4 Studio White emitter |
| LZ4-40SW08-xxxx | LZ4 Studio White emitter on Standard Star 1 channel MCPCB |

Bin kit option codes

| SW, Studio-White (5300K) | | | |
|--------------------------|--------------|-------------------|---|
| Kit number suffix | Min flux Bin | Chromaticity bins | Description |
| 0000 | T | 2D, 2C, 3A, 3B | full distribution flux; full distribution CCT |

Studio White Chromaticity Groups

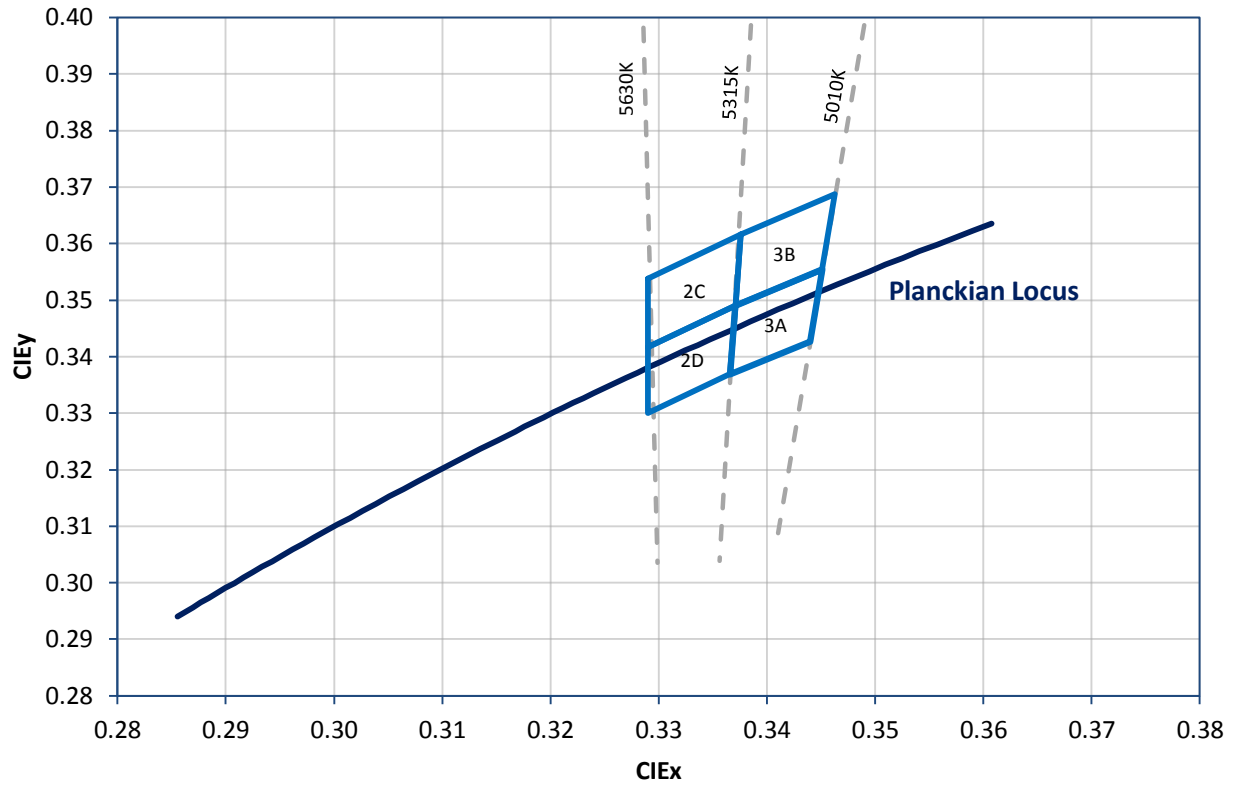

Standard Chromaticity Groups plotted on excerpt from the CIE 1931 (2°) x-y Chromaticity Diagram. Coordinates are listed below in the table.

Studio White Bin Coordinates

| Bin code | CIE _x | CIE _y | Bin code | CIE _x | CIE _y |
|----------|------------------|------------------|----------|------------------|------------------|
| 2D | 0.329 | 0.3417 | 2C | 0.329 | 0.3538 |
| | 0.3371 | 0.349 | | 0.3376 | 0.3616 |
| | 0.3366 | 0.3369 | | 0.3371 | 0.349 |
| | 0.329 | 0.33 | | 0.329 | 0.3417 |
| 3A | 0.329 | 0.3417 | 3B | 0.329 | 0.3538 |
| | 0.3371 | 0.349 | | 0.3376 | 0.3616 |
| | 0.3451 | 0.3554 | | 0.3463 | 0.3687 |
| | 0.344 | 0.3427 | | 0.3451 | 0.3554 |
| | 0.3366 | 0.3369 | | 0.3371 | 0.349 |
| | 0.3371 | 0.349 | | 0.3376 | 0.3616 |

Luminous Flux Bins

Table 1:

| Bin Code | Minimum Luminous Flux (Φ_v) @ $I_F = 700\text{mA}$^[1,2] (lm) | Maximum Luminous Flux (Φ_v) @ $I_F = 700\text{mA}$^[1,2] (lm) | Typical Luminous Flux (Φ_v) @ $I_F = 1000\text{mA}$^[2] (lm) |
|-----------------|---|---|--|
| T | 445 | 556 | 650 |
| U | 556 | 695 | 810 |

Notes for Table 1:

1. Luminous flux performance guaranteed within published operating conditions. LED Engin maintains a tolerance of $\pm 10\%$ on flux measurements.

Forward Voltage Bins

Table 2:

| Bin Code | Minimum Forward Voltage (V_F) @ $I_F = 700\text{mA}$^[1,2] (V) | Maximum Forward Voltage (V_F) @ $I_F = 700\text{mA}$^[1,2] (V) |
|-----------------|---|---|
| 0 | 12.0 | 14.4 |

Notes for Table 2:

1. Forward Voltage is binned with all four LED dice connected in series.
2. LED Engin maintains a tolerance of $\pm 0.4\text{V}$ for forward voltage measurements for the four LEDs.

Absolute Maximum Ratings

Table 3:

| Parameter | Symbol | Value | Unit |
|--|-----------|--|------|
| DC Forward Current ^[1] | I_F | 1000 | mA |
| Peak Pulsed Forward Current ^[2] | I_{FP} | 2000 | mA |
| Reverse Voltage | V_R | See Note 3 | V |
| Storage Temperature | T_{stg} | -40 ~ +150 | °C |
| Junction Temperature | T_J | 150 | °C |
| Soldering Temperature ^[4] | T_{sol} | 260 | °C |
| Allowable Reflow Cycles | | 6 | |
| Autoclave Conditions ^[5] | | 121°C at 2 ATM, 100% RH for 168 hours | |
| ESD Sensitivity ^[6] | | > 8,000 V HBM Class 3B JESD22-A114-D | |

Notes for Table 3:

- Maximum DC forward current (per die) is determined by the overall thermal resistance and ambient temperature. Follow the curves in Figure 10 for current derating.
- Pulse forward current conditions: Pulse Width \leq 10msec and Duty cycle \leq 10%.
- LEDs are not designed to be reverse biased.
- Solder conditions per JEDEC 020D. See Reflow Soldering Profile Figure 5.
- Autoclave Conditions per JEDEC JESD22-A102-C.
- LED Engin recommends taking reasonable precautions towards possible ESD damages and handling the LZ4-00SW08 in an electrostatic protected area (EPA). An EPA may be adequately protected by ESD controls as outlined in ANSI/ESD S6.1.

Optical Characteristics @ $T_C = 25^\circ\text{C}$

Table 4:

| Parameter | Symbol | Typical | Unit |
|---|-----------------|---------|---------|
| Luminous Flux (@ $I_F = 700\text{mA}$) ^[1] | Φ_V | 650 | lm |
| Luminous Flux (@ $I_F = 1000\text{mA}$) ^[1] | Φ_V | 845 | lm |
| Luminous Efficacy (@ $I_F = 350\text{mA}$) | | 91 | lm/W |
| Correlated Color Temperature | CCT | 5300 | K |
| Color Rendering Index (CRI) | R_a | 88 | |
| Viewing Angle ^[2] | $2\Theta_{1/2}$ | 105 | Degrees |
| Total Included Angle ^[3] | $\Theta_{0.9V}$ | 135 | Degrees |

Notes for Table 4:

- Luminous flux typical value is for all four LED dice operating concurrently at rated current.
- Viewing Angle is the off axis angle from emitter centerline where the luminous intensity is $\frac{1}{2}$ of the peak value.
- Total Included Angle is the total angle that includes 90% of the total luminous flux.

Electrical Characteristics @ $T_C = 25^\circ\text{C}$

Table 5:

| Parameter | Symbol | Typical | Unit |
|---|---------------------------|---------|-------|
| Forward Voltage (@ $I_F = 700\text{mA}$) ^[1] | V_F | 12.9 | V |
| Forward Voltage (@ $I_F = 1000\text{mA}$) ^[1] | V_F | 13.3 | V |
| Temperature Coefficient of Forward Voltage ^[1] | $\Delta V_F / \Delta T_J$ | -8.0 | mV/°C |
| Thermal Resistance (Junction to Case) | $R\Theta_{J-C}$ | 2.8 | °C/W |

Notes for Table 5:

- Forward Voltage typical value is for all four LED dice connected in series.

IPC/JEDEC Moisture Sensitivity Level

Table 6 - IPC/JEDEC J-STD-20D.1 MSL Classification:

| Level | Floor Life | | Soak Requirements | | | |
|-------|------------|-------------------|-------------------|-----------------|------------|-------------|
| | Time | Conditions | Standard | Accelerated | Standard | Accelerated |
| | Time | Conditions | Time (hrs) | Conditions | Time (hrs) | Conditions |
| 1 | Unlimited | ≤ 30°C/ 85% RH | 168 +5/-0 | 85°C/ 85% RH | n/a | n/a |

Notes for Table 6:

1. The standard soak time includes a default value of 24 hours for semiconductor manufacturer's exposure time (MET) between bake and bag and includes the maximum time allowed out of the bag at the distributor's facility.

Average Lumen Maintenance Projections

Lumen maintenance generally describes the ability of a lamp to retain its output over time. The useful lifetime for solid state lighting devices (Power LEDs) is also defined as Lumen Maintenance, with the percentage of the original light output remaining at a defined time period.

Based on long-term WHTOL testing, LED Engin projects that the LZ4 Series will deliver, on average, 90% Lumen Maintenance at 65,000 hours of operation at a forward current of 700 mA per die. This projection is based on constant current operation with junction temperature maintained at or below 110°C.

Mechanical Dimensions (mm)

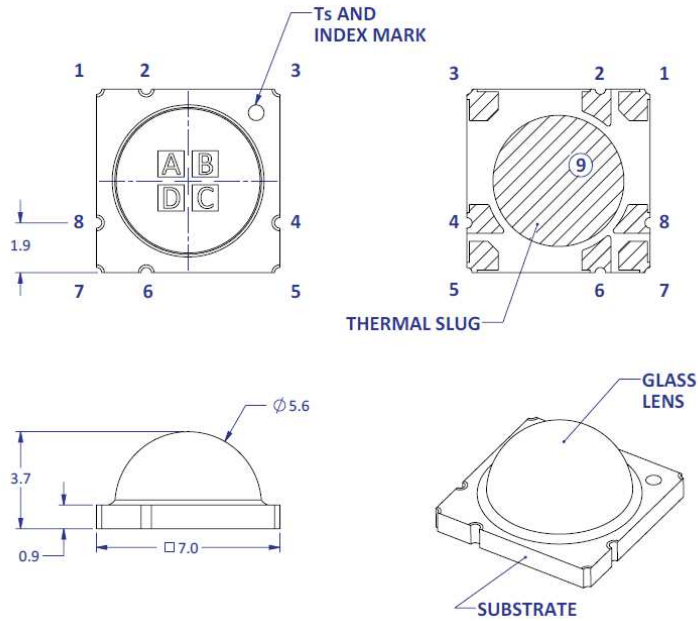

| Pin Out | | |
|------------------|-----|----------|
| Pad | Die | Function |
| 1 | A | Anode |
| 2 | A | Cathode |
| 3 | B | Anode |
| 4 | B | Cathode |
| 5 | C | Anode |
| 6 | C | Cathode |
| 7 | D | Anode |
| 8 | D | Cathode |
| 9 ^[2] | n/a | Thermal |

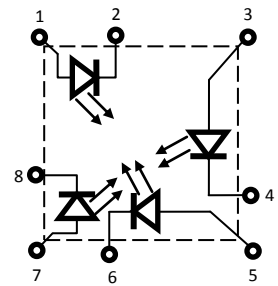

Figure 1: Package outline drawing.

Notes for Figure 1:

1. Index mark, Ts indicates case temperature measurement point.
2. Unless otherwise noted, the tolerance = ± 0.20 mm.
3. Thermal contact, Pad 9, is electrically neutral.

Recommended Solder Pad Layout (mm)

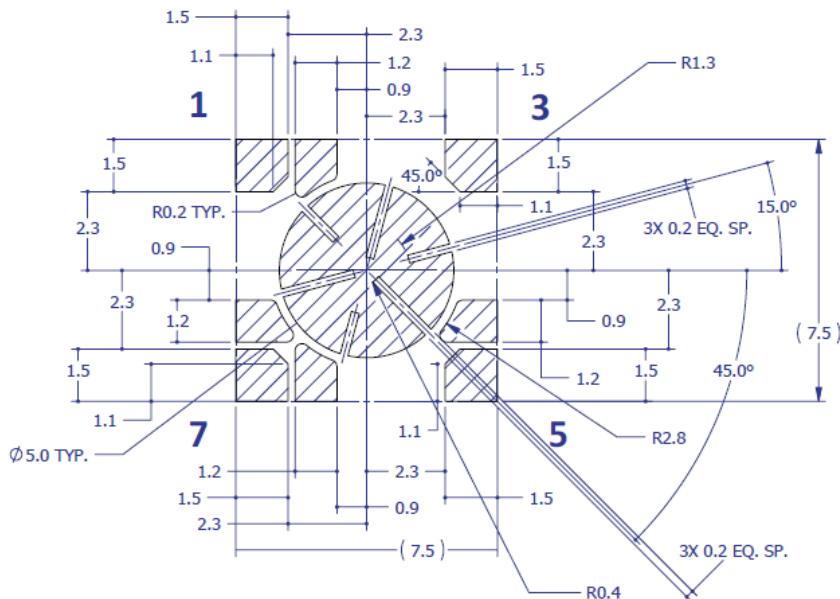

Figure 2a: Recommended solder pad layout for anode, cathode, and thermal pad.

Note for Figure 2a:

1. Unless otherwise noted, the tolerance = ± 0.20 mm.
2. This pad layout is "patent pending".

Recommended 8mil Stencil Apertures Layout (mm)

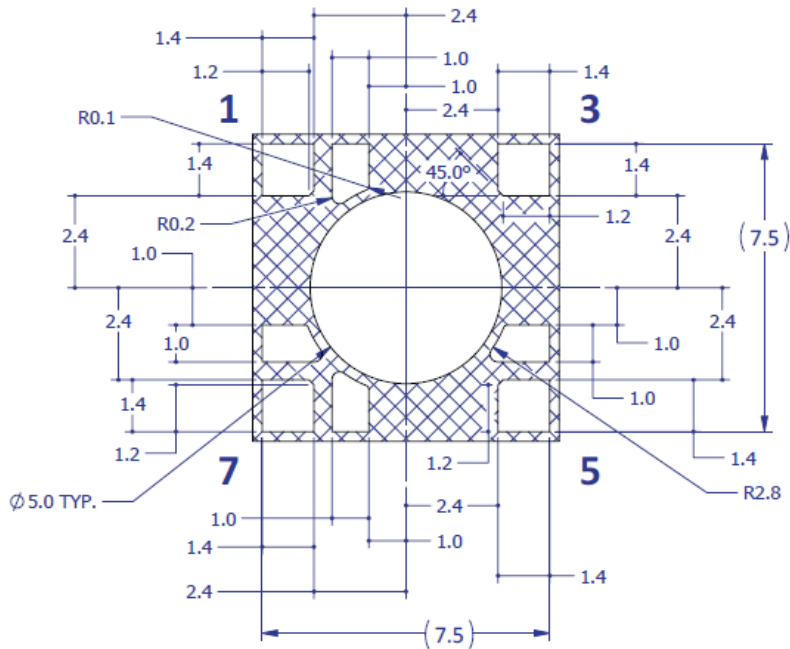

Figure 2b: Recommended solder mask opening (hatched area) for anode, cathode, and thermal pad.

Note for Figure 2b:

1. Unless otherwise noted, the tolerance = ± 0.20 mm.

Reflow Soldering Profile

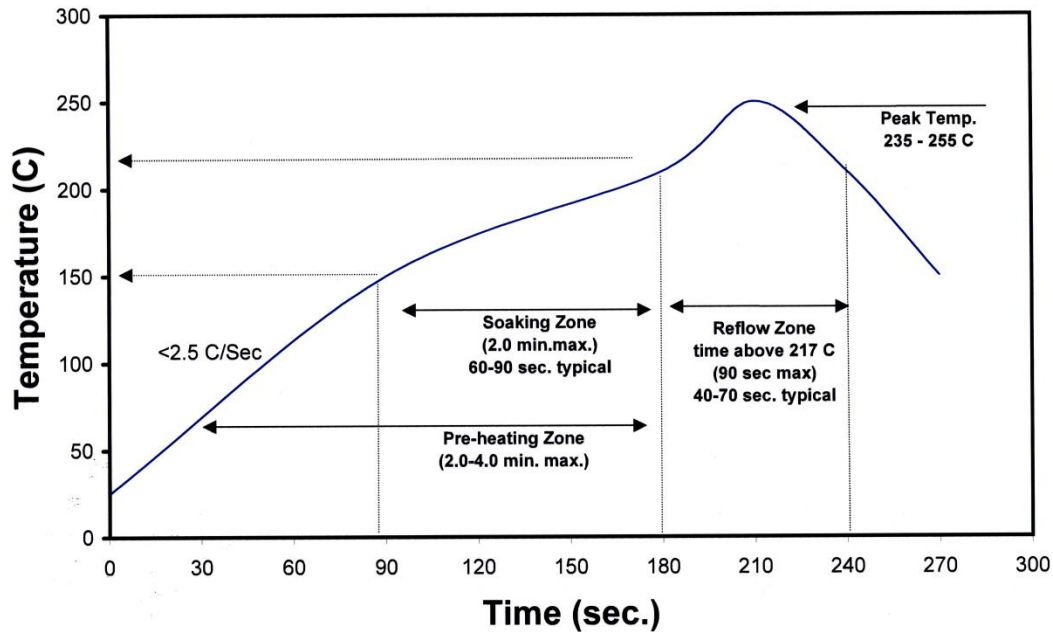

Figure 3: Reflow soldering profile for lead free soldering.

Typical Radiation Pattern

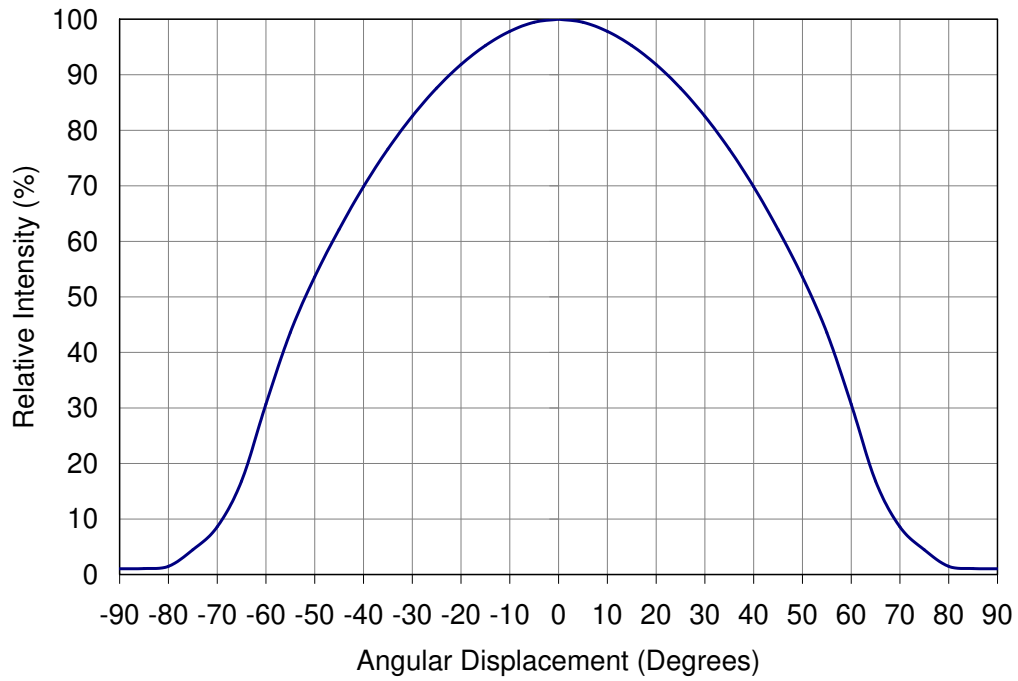

Figure 4: Typical representative spatial radiation pattern.

Typical Relative Spectral Power Distribution

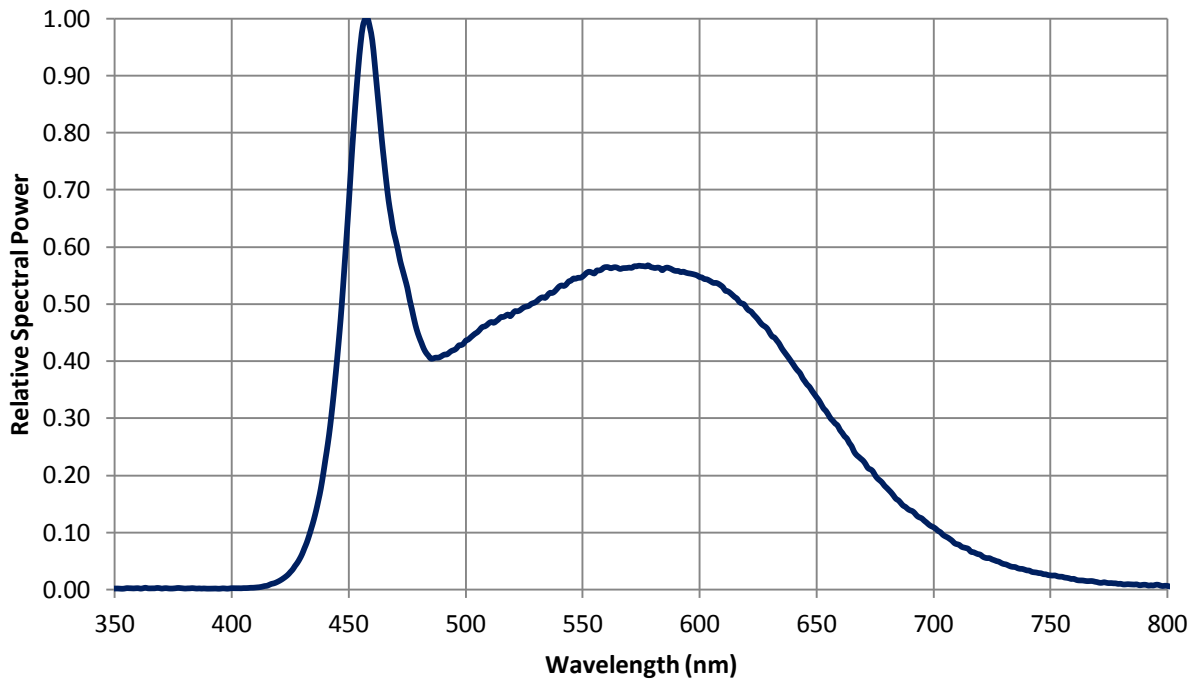

Figure 5: Typical relative spectral power vs. wavelength @ T_c = 25°C.

Typical Chromaticity Coordinate Shift over Temperature

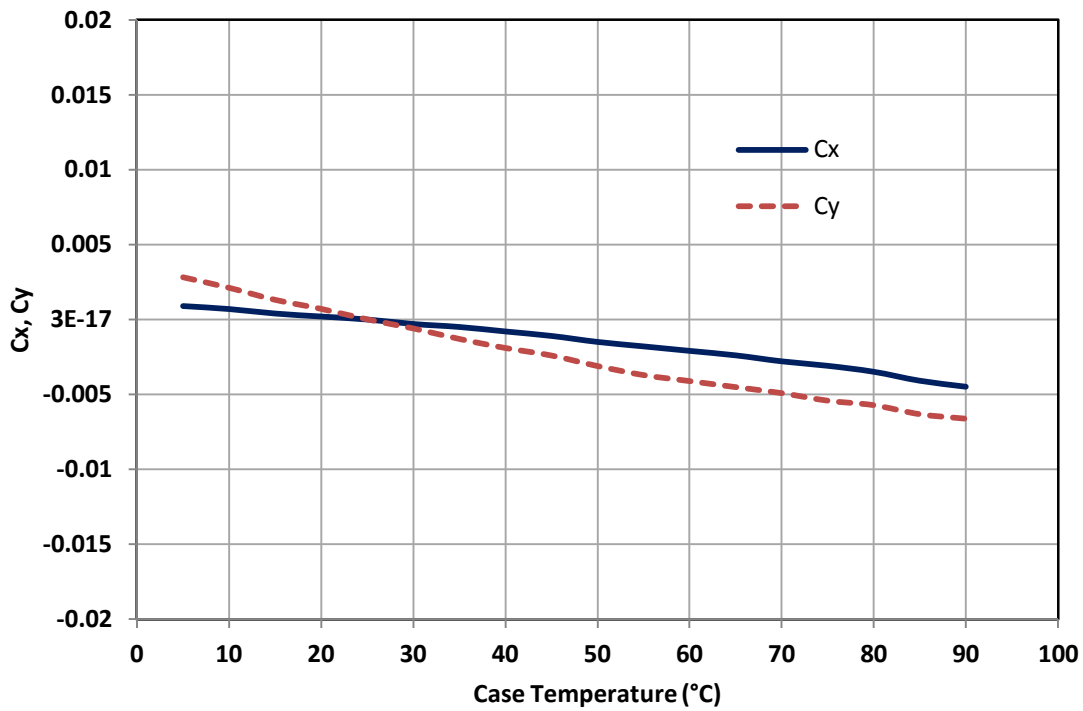

Figure 6: Typical chromaticity coordinate shift vs. Case temperature

Typical Relative Light Output

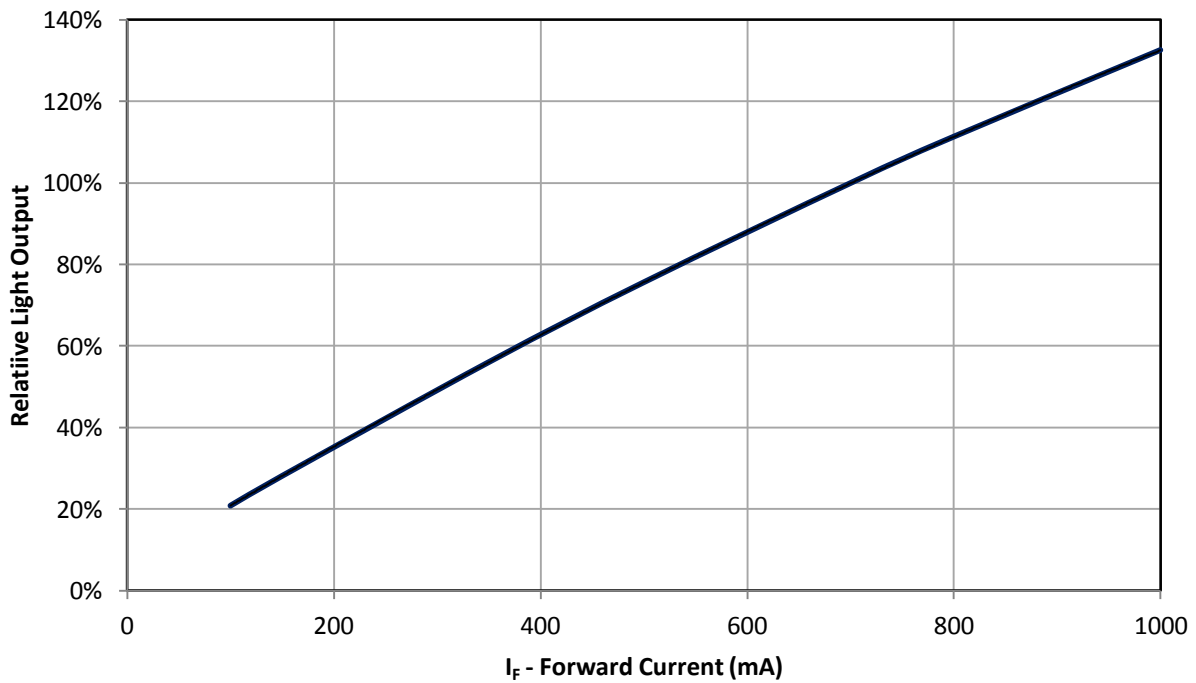

Figure 7: Typical relative light output vs. forward current @ T_c = 25°C.

Typical Relative Light Output over Temperature

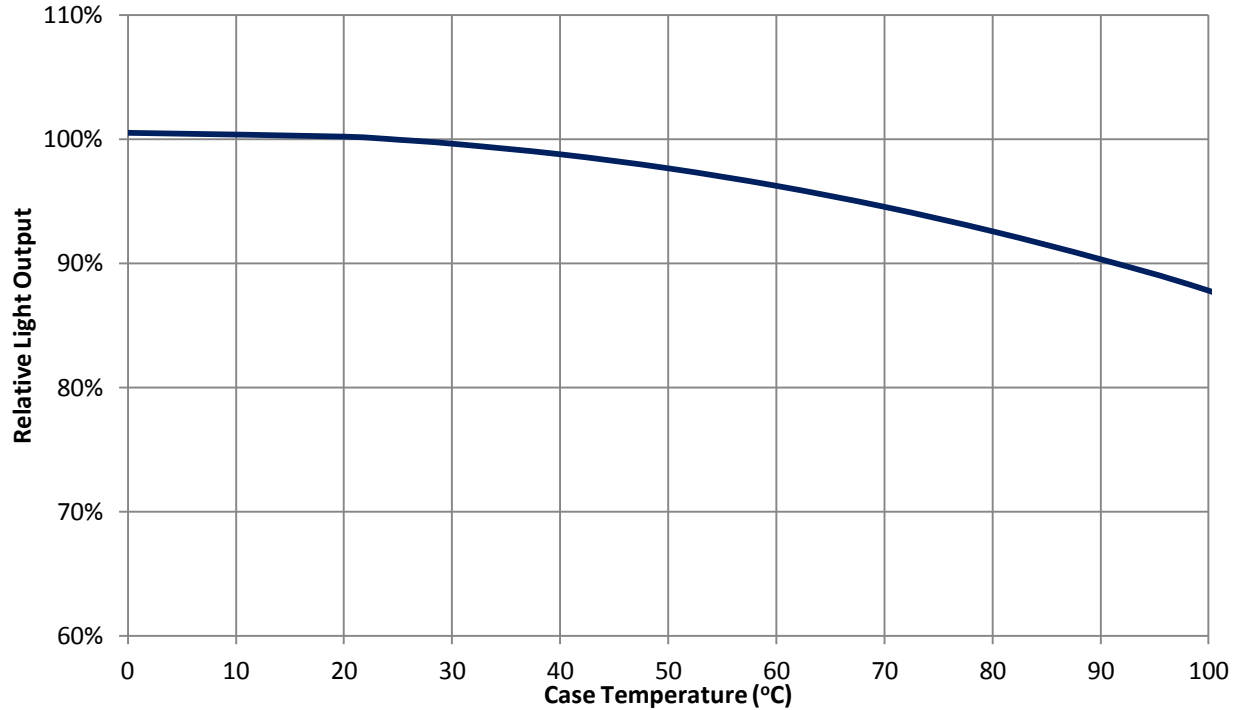

Figure 8: Typical relative light output vs. case temperature.

Typical Forward Current Characteristics

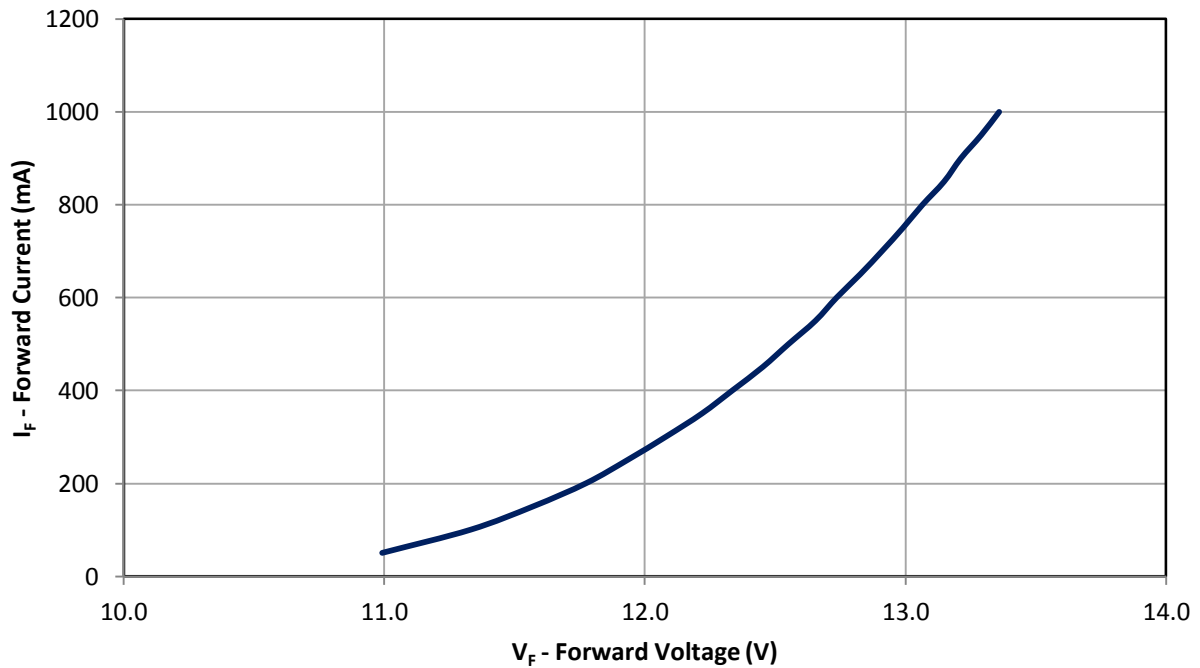

Figure 9: Typical forward current vs. forward voltage @ T_C = at 25°C.

Note for Figure 9:

1. Forward Voltage curve assumes that all four LED dice are connected in series.

Current De-rating

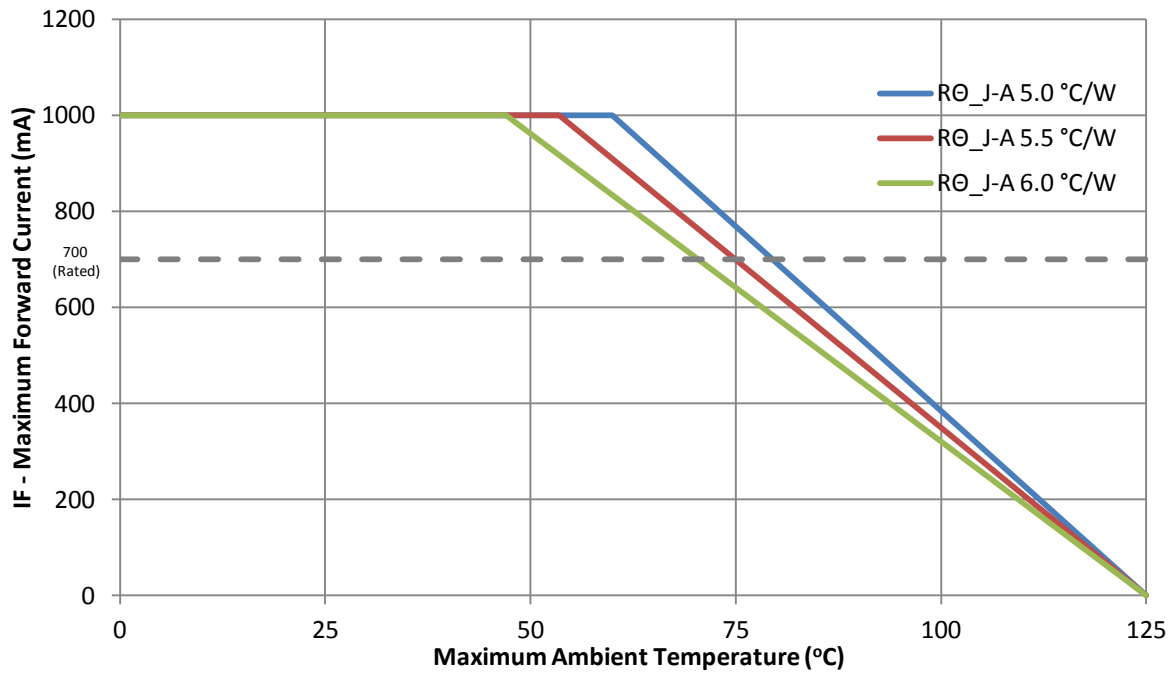

Figure 10: Maximum forward current vs. ambient temperature based on $T_{J(MAX)} = 150^{\circ}C$.

Notes for Figure 10:

1. Maximum current assumes that all four LED dice are operating concurrently at the same current.
2. $R_{\theta_{J-C}}$ [Junction to Case Thermal Resistance] for the LZ4-00SW08 is typically $2.8^{\circ}C/W$.
3. $R_{\theta_{J-A}}$ [Junction to Ambient Thermal Resistance] = $R_{\theta_{J-C}} + R_{\theta_{C-A}}$ [Case to Ambient Thermal Resistance].

Emitter Tape and Reel Specifications (mm)

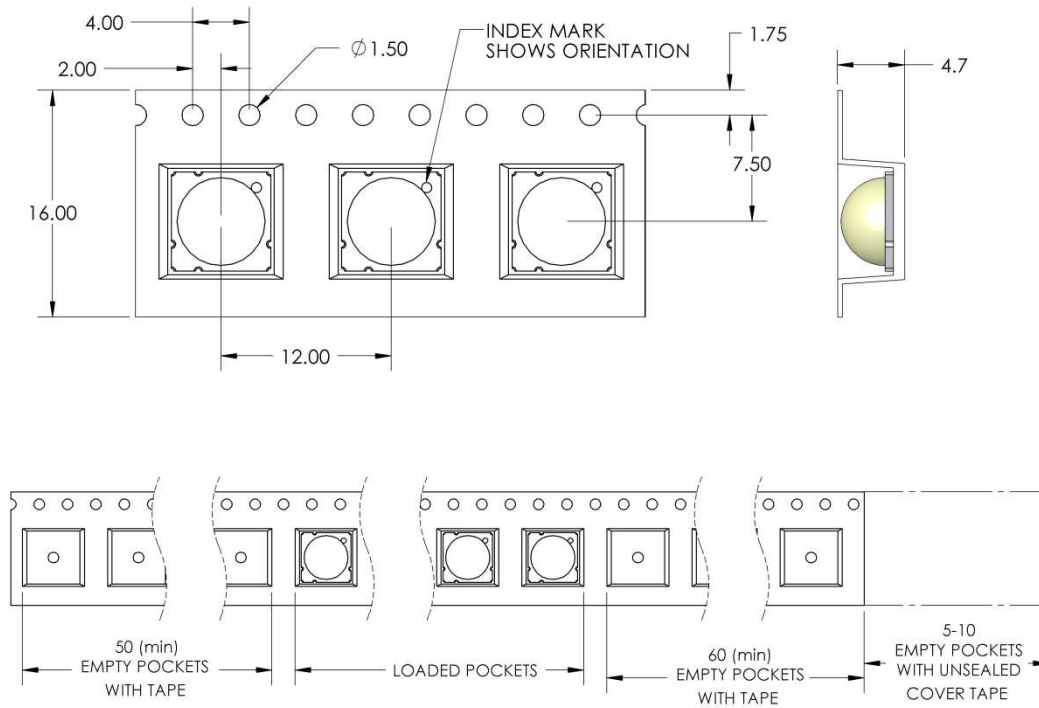

Figure 11: Emitter carrier tape specifications (mm).

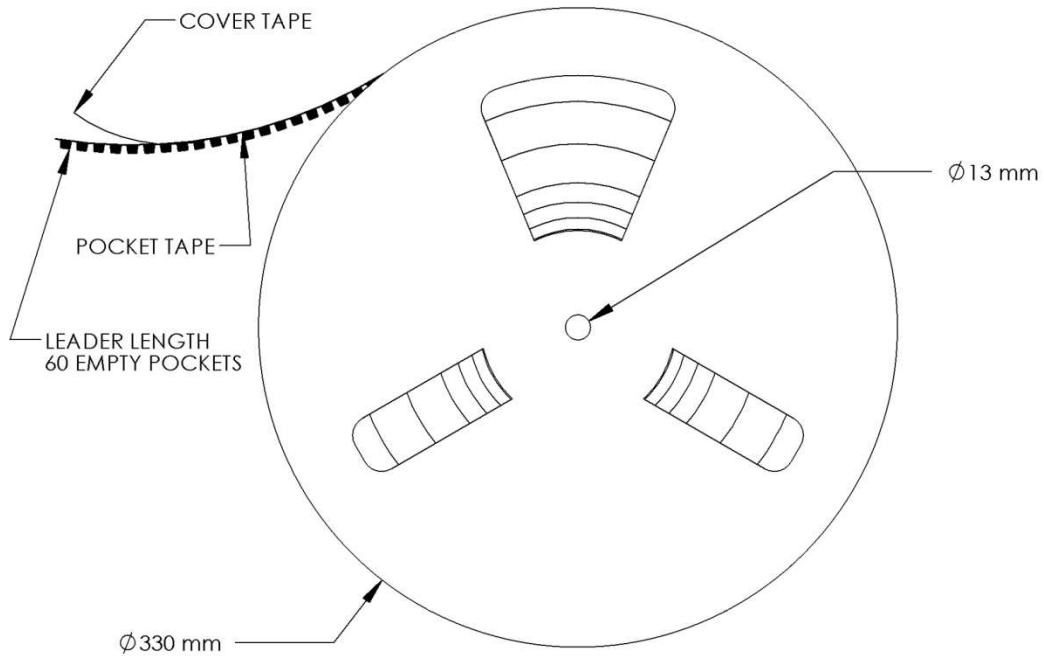

Figure 12: Emitter Reel specifications (mm).

LZ4 MCPCB Family

| Part number | Type of MCPCB | Diameter (mm) | Emitter + MCPCB Thermal Resistance (°C/W) | Typical V_f (V) | Typical I_f (mA) |
|-------------|---------------|---------------|---|-------------------|--------------------|
| LZ4-4xxxxxx | 1-channel | 19.9 | 2.8 + 1.1 = 3.9 | 12.9 | 700 |

Mechanical Mounting of MCPCB

- MCPCB bending should be avoided as it will cause mechanical stress on the emitter, which could lead to substrate cracking and subsequently LED dies cracking.
- To avoid MCPCB bending:
 - Special attention needs to be paid to the flatness of the heat sink surface and the torque on the screws.
 - Care must be taken when securing the board to the heat sink. This can be done by tightening three M3 screws (or #4-40) in steps and not all the way through at once. Using fewer than three screws will increase the likelihood of board bending.
 - It is recommended to always use plastics washers in combinations with the three screws.
 - If non-taped holes are used with self-tapping screws, it is advised to back out the screws slightly after tightening (with controlled torque) and then re-tighten the screws again.

Thermal interface material

- To properly transfer heat from LED emitter to heat sink, a thermally conductive material is required when mounting the MCPCB on to the heat sink.
- There are several varieties of such material: thermal paste, thermal pads, phase change materials and thermal epoxies. An example of such material is Electrolube EHTC.
- It is critical to verify the material's thermal resistance to be sufficient for the selected emitter and its operating conditions.

Wire soldering

- To ease soldering wire to MCPCB process, it is advised to preheat the MCPCB on a hot plate of 125-150°C. Subsequently, apply the solder and additional heat from the solder iron will initiate a good solder reflow. It is recommended to use a solder iron of more than 60W.
- It is advised to use lead-free, no-clean solder. For example: SN-96.5 AG-3.0 CU 0.5 #58/275 from Kester (pn: 24-7068-7601)

LZ4-4xxxxx

1 channel, Standard Star MCPCB (1x4) Dimensions (mm)

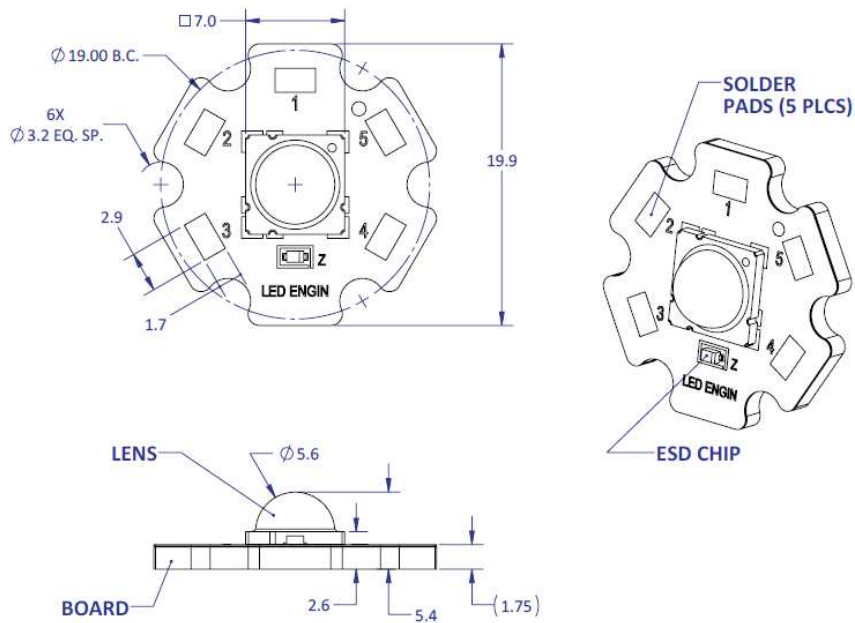

Notes:

- Unless otherwise noted, the tolerance = ± 0.2 mm.
- Slots in MCPCB are for M3 or #4-40 mounting screws.
- LED Engin recommends plastic washers to electrically insulate screws from solder pads and electrical traces.
- LED Engin recommends thermal interface material when attaching the MCPCB to a heatsink
- The thermal resistance of the MCPCB is: $R_{\theta C-B}$ 1.1°C/W

Components used

MCPCB: HT04503 (Bergquist)
 ESD chips: BZX585-C30 (NPX, for 4 LED dies in series)

| Pad layout | | | |
|------------|-----------|------------|-----------|
| Ch. | MCPCB Pad | String/die | Function |
| 1 | 1,2,3 | 1/ABCD | Cathode - |
| | 4,5 | | Anode + |

Company Information

LED Engin, based in California's Silicon Valley, develops, manufactures, and sells advanced LED emitters, optics and light engines to create uncompromised lighting experiences for a wide range of entertainment, architectural, general lighting and specialty applications. LuxiGen™ multi-die emitter and secondary lens combinations reliably deliver industry-leading flux density, upwards of 5000 quality lumens to a target, in a wide spectrum of colors including whites, tunable whites, multi-color and UV LEDs in a unique patented compact ceramic package. Our LuxiTune™ series of tunable white lighting modules leverage our LuxiGen emitters and lenses to deliver quality, control, freedom and high density tunable white light solutions for a broad range of new recessed and downlighting applications. The small size, yet remarkably powerful beam output and superior in-source color mixing, allows for a previously unobtainable freedom of design wherever high-flux density, directional light is required.

LED Engin is committed to providing products that conserve natural resources and reduce greenhouse emissions.

LED Engin reserves the right to make changes to improve performance without notice.

Please contact sales@ledengin.com or (408) 922-7200 for more information.