



Chipsmall Limited consists of a professional team with an average of over 10 year of expertise in the distribution of electronic components. Based in Hongkong, we have already established firm and mutual-benefit business relationships with customers from,Europe,America and south Asia,supplying obsolete and hard-to-find components to meet their specific needs.

With the principle of "Quality Parts,Customers Priority,Honest Operation,and Considerate Service",our business mainly focus on the distribution of electronic components. Line cards we deal with include Microchip,ALPS,ROHM,Xilinx,Pulse,ON,Everlight and Freescale. Main products comprise IC,Modules,Potentiometer,IC Socket,Relay,Connector.Our parts cover such applications as commercial,industrial, and automotives areas.

We are looking forward to setting up business relationship with you and hope to provide you with the best service and solution. Let us make a better world for our industry!



## Contact us

Tel: +86-755-8981 8866 Fax: +86-755-8427 6832

Email & Skype: info@chipsmall.com Web: www.chipsmall.com

Address: A1208, Overseas Decoration Building, #122 Zhenhua RD., Futian, Shenzhen, China



# Studio White LED Emitter

## LZ9-00SW00



### Key Features

- 9-die Studio White (5300K) LED
- CCT and color rendering matched to HID arc lamp
- CRI85 minimum / R9 50 typical
- Up to 20 Watt power dissipation on compact 7.0mm x 7.0mm footprint
- Low Thermal Resistance (1.3°C/W)
- Engineered ceramic package with integrated glass lens
- Very high Luminous Flux density
- JEDEC Level 1 for Moisture Sensitivity Level
- Autoclave compliant (JEDEC JESD22-A102-C)
- Lead (Pb) free and RoHS compliant
- Reflow solderable (up to 6 cycles)
- Emitter available on MCPCB (optional)
- Full suite of TIR secondary optics family available

### Typical Applications

- Studio Lighting
- Photography Lighting
- High-end retail Lighting
- Showrooms Lighting

### Part Number Options

#### Base part number

Part number	Description
LZ9-00SW00-xxxx	9-die emitter Studio White
LZ9-J0SW00-xxxx	9-die emitter Studio White on Star MCPCB in 1x9 electrical configuration
LZ9-M0SW00-xxxx	9-die emitter Studio White on Star MCPCB in 3x3 electrical configuration

**Bin Kit Option Codes**

<b>SW, Studio-White (5300K)</b>			
<b>Kit number suffix</b>	<b>Min flux Bin</b>	<b>Color Bin Ranges</b>	<b>Description</b>
0000	X	2D, 2C, 3A, 3B	full distribution flux; full distribution CCT

## Studio White Chromaticity Groups

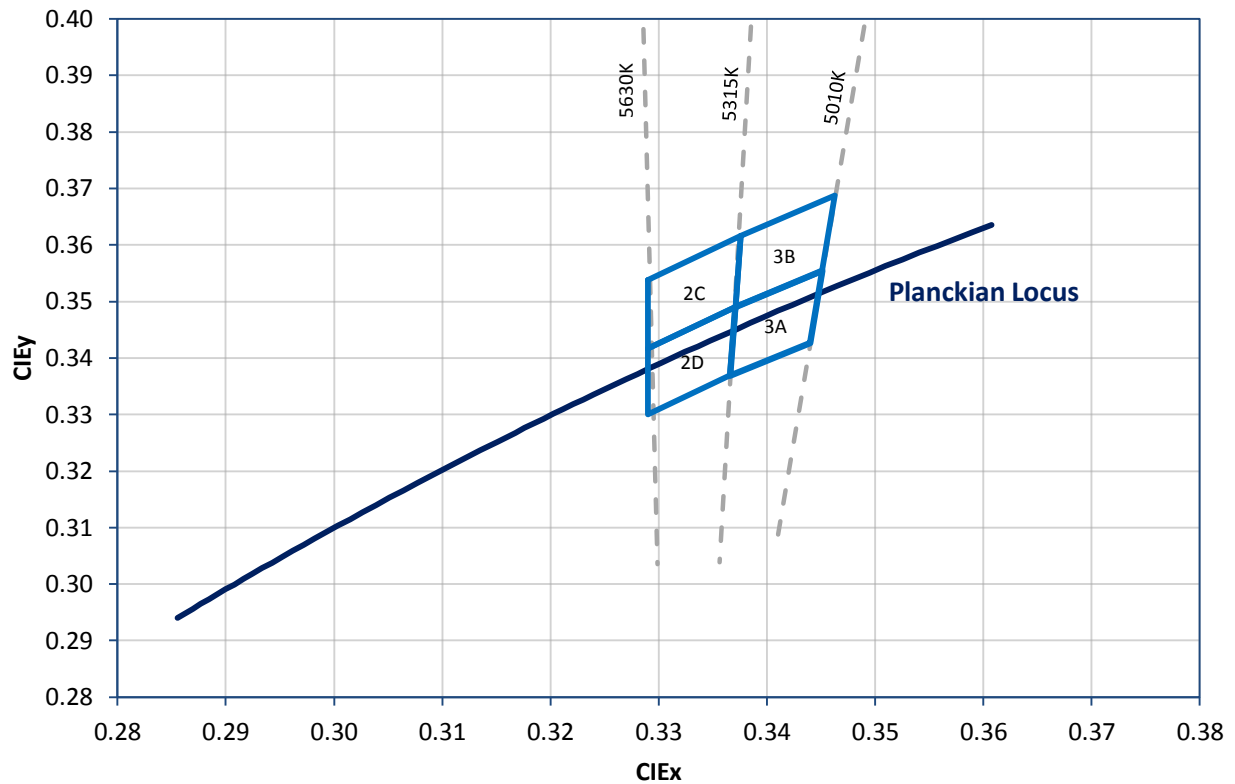

Standard Chromaticity Groups plotted on excerpt from the CIE 1931 (2°) x-y Chromaticity Diagram. Coordinates are listed below in the table.

## Studio White Bin Coordinates

Bin code	CIE <sub>x</sub>	CIE <sub>y</sub>	Bin code	CIE <sub>x</sub>	CIE <sub>y</sub>
2D	0.329	0.3417	2C	0.329	0.3538
	0.3371	0.349		0.3376	0.3616
	0.3366	0.3369		0.3371	0.349
	0.329	0.33		0.329	0.3417
	0.329	0.3417		0.329	0.3538
3A	0.3371	0.349	3B	0.3376	0.3616
	0.3451	0.3554		0.3463	0.3687
	0.344	0.3427		0.3451	0.3554
	0.3366	0.3369		0.3371	0.349
	0.3371	0.349		0.3376	0.3616

## Luminous Flux Bins

Table 1:

<b>Bin Code</b>	<b>Minimum Luminous Flux (<math>\Phi_v</math>) @ <math>I_F = 700\text{mA}</math> <sup>[1,2]</sup> (lm)</b>	<b>Maximum Luminous Flux (<math>\Phi_v</math>) @ <math>I_F = 700\text{mA}</math> <sup>[1,2]</sup> (lm)</b>
X	1085	1357
Y	1357	1696

Notes for Table 1:

1. Luminous flux performance guaranteed within published operating conditions. LED Engin maintains a tolerance of  $\pm 10\%$  on flux measurements.

## Forward Voltage Range per String

Table 2:

<b>Bin Code</b>	<b>Minimum Forward Voltage (<math>V_F</math>) @ <math>I_F = 700\text{mA}</math> <sup>[1,2]</sup> (V)</b>	<b>Maximum Forward Voltage (<math>V_F</math>) @ <math>I_F = 700\text{mA}</math> <sup>[1,2]</sup> (V)</b>
0	9.0	10.8

Notes for Table 2:

1. LED Engin maintains a tolerance of  $\pm 0.04\text{V}$  for forward voltage measurements.
2. Forward Voltage per string of 3 LED dies in series.



## Absolute Maximum Ratings

Table 3:

Parameter	Symbol	Value	Unit
DC Forward Current at $T_{jmax}=135^{\circ}\text{C}^{[1]}$	$I_F$	800	mA
DC Forward Current at $T_{jmax}=150^{\circ}\text{C}^{[1]}$	$I_F$	700	mA
Peak Pulsed Forward Current <sup>[2]</sup>	$I_{FP}$	1000	mA
Reverse Voltage	$V_R$	See Note 3	V
Storage Temperature	$T_{stg}$	-40 ~ +150	$^{\circ}\text{C}$
Junction Temperature	$T_J$	150	$^{\circ}\text{C}$
Soldering Temperature <sup>[4]</sup>	$T_{sol}$	260	$^{\circ}\text{C}$
Allowable Reflow Cycles		6	
Autoclave Conditions <sup>[5]</sup>		121 $^{\circ}\text{C}$ at 2 ATM, 100% RH for 168 hours	
ESD Sensitivity <sup>[6]</sup>		> 8,000 V HBM Class 3B JESD22-A114-D	

Notes for Table 3:

- Maximum DC forward current (per die) is determined by the overall thermal resistance and ambient temperature. Follow the curves in Figure 10 for current de-rating.
- Pulse forward current conditions: Pulse Width  $\leq 10\text{msec}$  and Duty Cycle  $\leq 10\%$ .
- LEDs are not designed to be reverse biased.
- Solder conditions per JEDEC 020c. See Reflow Soldering Profile Figure 3.
- Autoclave Conditions per JEDEC JESD22-A102-C.
- LED Engin recommends taking reasonable precautions towards possible ESD damages and handling the LZ9-00SW00 in an electrostatic protected area (EPA). An EPA may be adequately protected by ESD controls as outlined in ANSI/ESD S6.1.

## Optical Characteristics @ $T_C = 25^{\circ}\text{C}$

Table 4:

Parameter	Symbol	Typical	Unit
Luminous Flux (@ $I_F = 700\text{mA}$ ) <sup>[1]</sup>	$\Phi_v$	1430	lm
Luminous Efficacy (@ $I_F = 350\text{mA}$ )		89	lm/W
Correlated Color Temperature	CCT	5300	K
Color Rendering Index (CRI)	$R_a$	88	
Viewing Angle <sup>[2]</sup>	$2\theta_{\frac{1}{2}}$	110	Degrees
Total Included Angle <sup>[3]</sup>	$\theta_{0.9}$	135	Degrees

Notes for Table 4:

- Luminous flux typical value is for all 9 LED dies operating concurrently at rated current.
- Viewing Angle is the off axis angle from emitter centerline where the luminous intensity is  $\frac{1}{2}$  of the peak value.
- Total Included Angle is the total angle that includes 90% of the total luminous flux.

## Electrical Characteristics @ $T_C = 25^{\circ}\text{C}$

Table 5:

Parameter	Symbol	Typical	Unit
Forward Voltage per String (@ $I_F = 700\text{mA}$ )	$V_F$	9.7	V
Temperature Coefficient of Forward Voltage (per String)	$\Delta V_F / \Delta T_J$	-6.0	mV/ $^{\circ}\text{C}$
Thermal Resistance (Junction to Case)	$R\theta_{J-C}$	1.3	$^{\circ}\text{C}/\text{W}$

## IPC/JEDEC Moisture Sensitivity Level

Table 6 - IPC/JEDEC J-STD-20 MSL Classification:

Level	Floor Life		Soak Requirements			
	Time	Conditions	Standard	Accelerated	Time (hrs)	Conditions
1	Unlimited	≤ 30°C/ 85% RH	168 +5/-0	85°C/ 85% RH	n/a	n/a

Notes for Table 1:

- The standard soak time is the sum of the default value of 24 hours for the semiconductor manufacturer's exposure time (MET) between bake and bag and the floor life of maximum time allowed out of the bag at the end user of distributor's facility.

## Average Lumen Maintenance Projections

Lumen maintenance generally describes the ability of a lamp to retain its output over time. The useful lifetime for solid state lighting devices (Power LEDs) is also defined as Lumen Maintenance, with the percentage of the original light output remaining at a defined time period.

Based on accelerated lifetime testing, LED Engin projects that the LZ Series will deliver, on average, 70% Lumen Maintenance at 65,000 hours of operation at a forward current of 700mA per die. This projection is based on constant current operation with junction temperature maintained at or below 120°C.

## Mechanical Dimensions (mm)

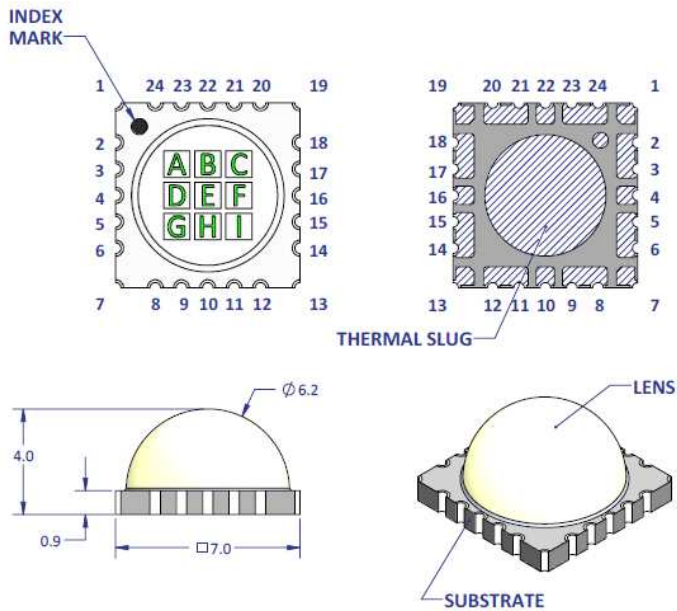

Figure 1: Package outline drawing.

Notes for Figure 1:

1. Index mark indicates case temperature measurement point.
2. Unless otherwise noted, the tolerance =  $\pm 0.20$  mm.

Emitter pin layout			
Emitter channel	Emitter pin	Die	Color
Ch1 -	23, 24	E	White
Ch1		B	White
Ch1 +	17, 18	A	White
Ch2 -	2, 3	G	White
Ch2		I	White
Ch2 +	14, 15	C	White
Ch3 -	5, 6	D	White
Ch3		H	White
Ch3 +	11, 12	F	White
NC pins: 1, 4, 7, 8, 9, 10, 13, 16, 19, 20, 21, 22			
DNC pins: none			

Notes:

- NC = Not internally Connected (Electrically isolated)  
DNC = Do Not Connect (Electrically Non isolated)

## Recommended Solder Pad Layout (mm)

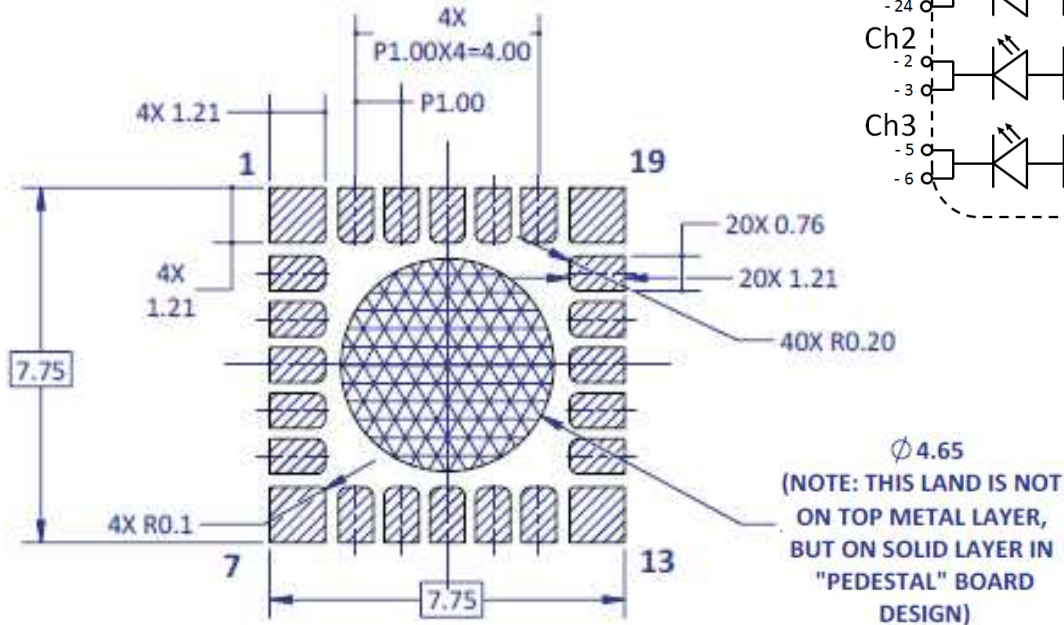
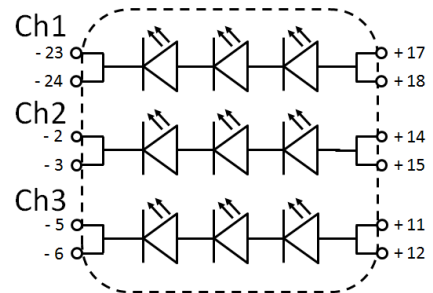

Figure 2a: Recommended solder pad layout for anode, cathode, and thermal pad.

Note for Figure 2a:

1. Unless otherwise noted, the tolerance =  $\pm 0.20$  mm.
2. LED Engin recommends the use of pedestal MCPCB's which allow the emitter thermal slug to be soldered directly to the metal core of the MCPCB. Such MCPCB technology eliminates the high thermal resistance dielectric layer that standard MCPCB technologies use in between the emitter thermal slug and the metal core of the MCPCB, thus lowering the overall system thermal resistance.
3. LED Engin recommends x-ray sample monitoring to screen for solder voids underneath the emitter thermal slug. The total area covered by solder voids should be less than 20% of the total emitter thermal slug area. Excessive solder voids will increase the emitter to MCPCB thermal resistance and may lead to higher failure rates due to thermal over stress.





### Recommended Solder Mask Layout (mm)

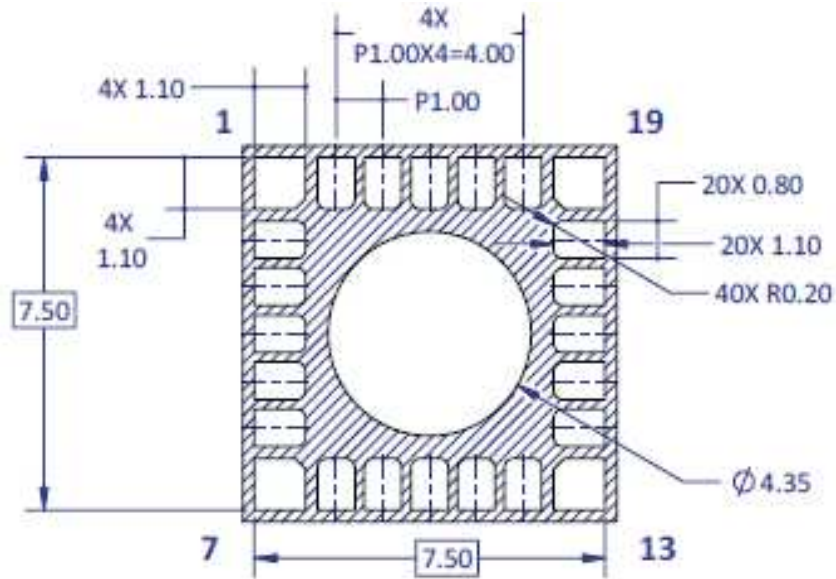

Figure 2b: Recommended solder mask opening (hatched area) for anode, cathode, and thermal pad.

Note for Figure 2b:

1. Unless otherwise noted, the tolerance =  $\pm 0.20$  mm.

### Recommended 8mil Stencil Apertures Layout (mm)

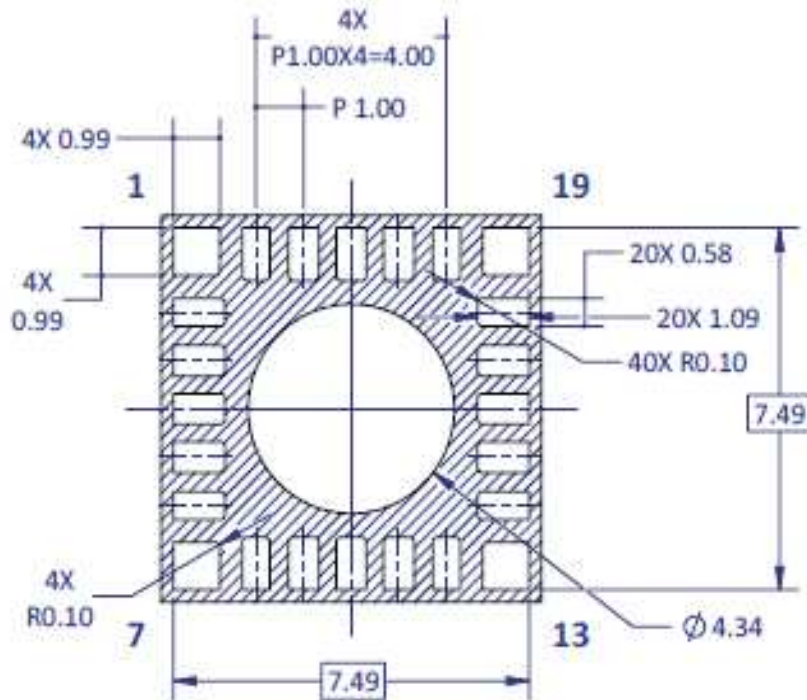

Figure 2c: Recommended 8mil stencil apertures layout for anode, cathode, and thermal pad.

Note for Figure 2c:

1. Unless otherwise noted, the tolerance =  $\pm 0.20$  mm.

### Reflow Soldering Profile

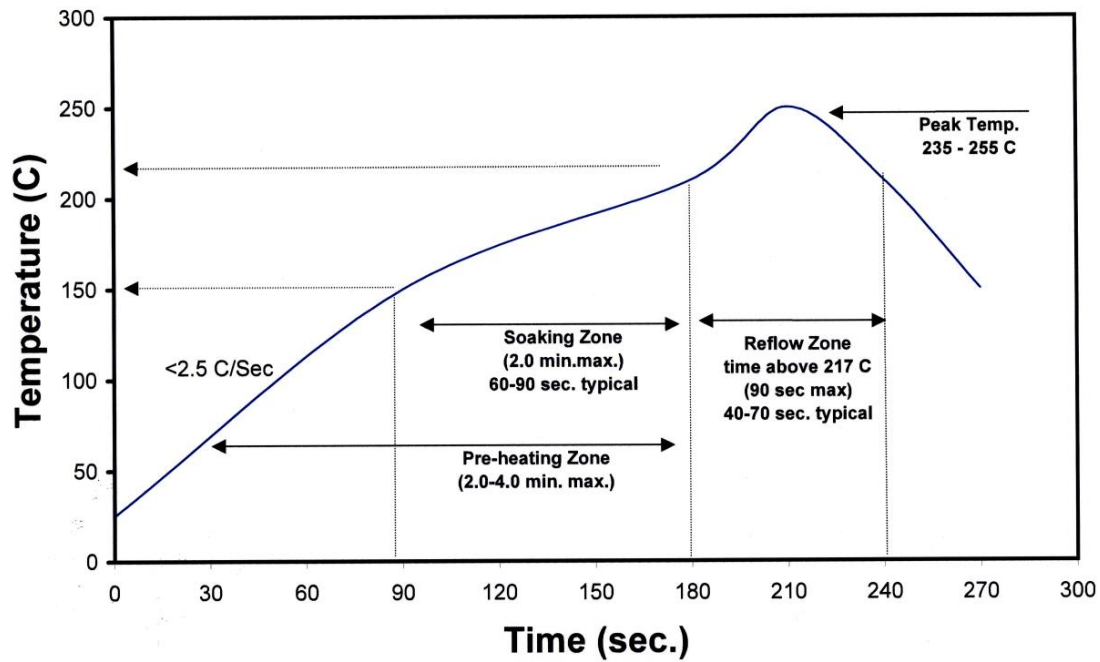

Figure 3: Reflow soldering profile for lead free soldering.

### Typical Radiation Pattern

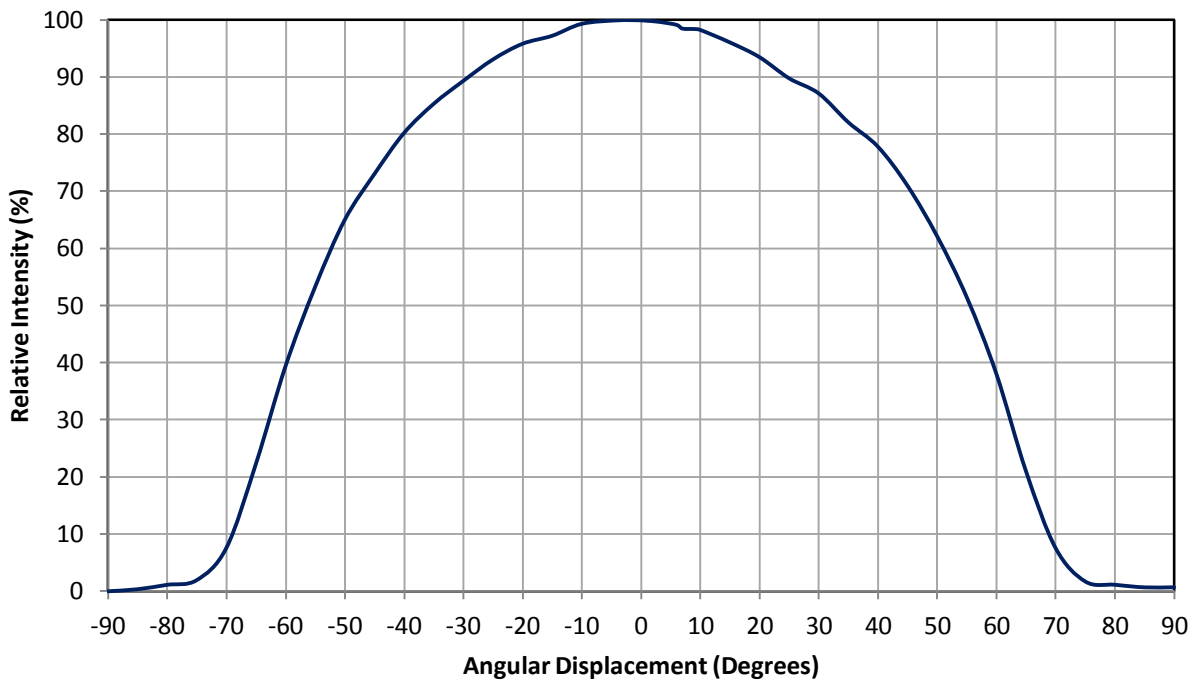

Figure 4: Typical representative spatial radiation pattern.

### Typical Relative Spectral Power Distribution

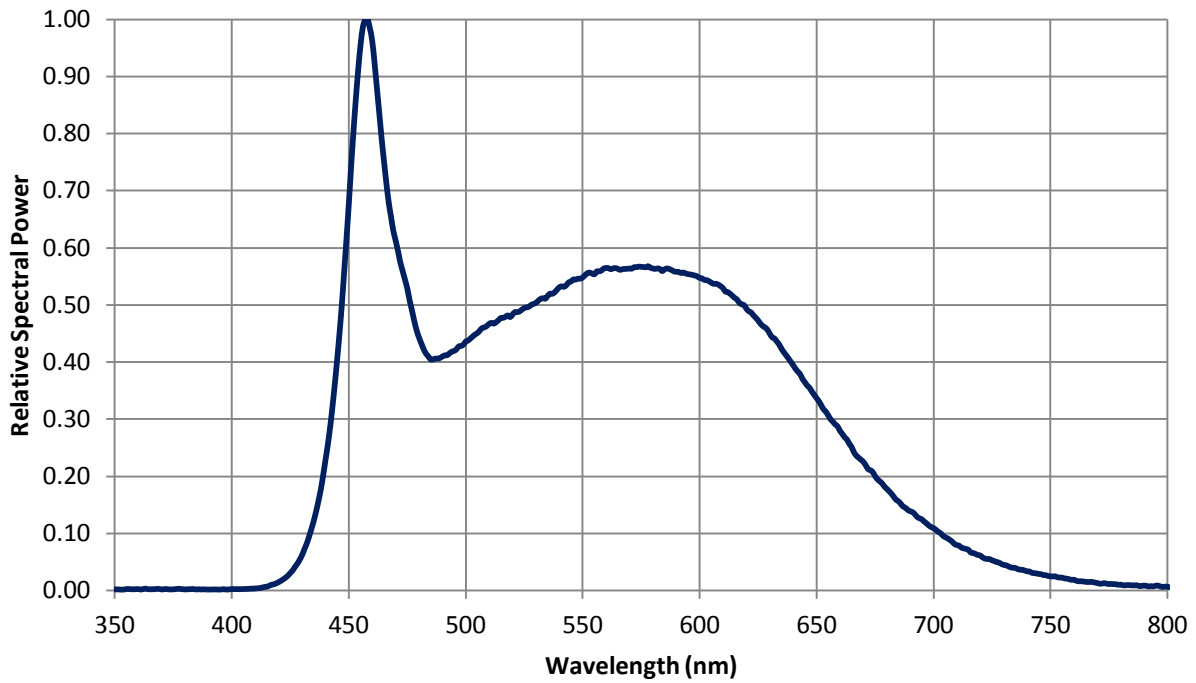

Figure 5: Typical relative spectral power vs. wavelength @  $T_c = 25^\circ\text{C}$

### Typical Chromaticity Coordinate Shift over Temperature

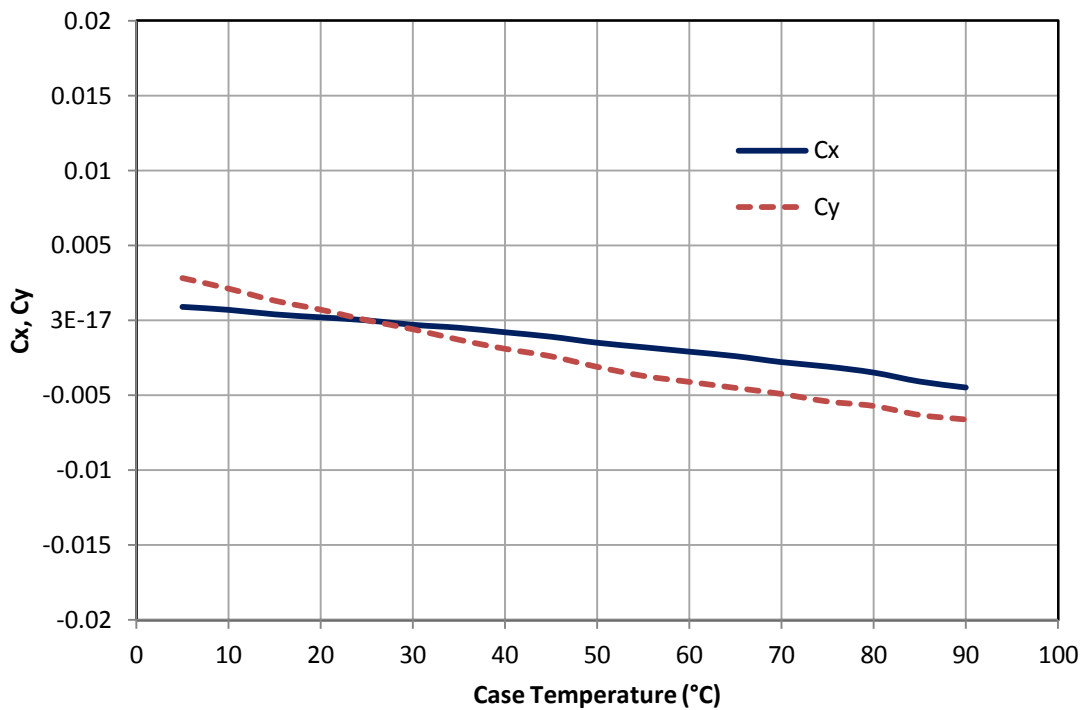

Figure 6: Typical chromaticity coordinate shift vs. Case temperature.

### Typical Relative Light Output

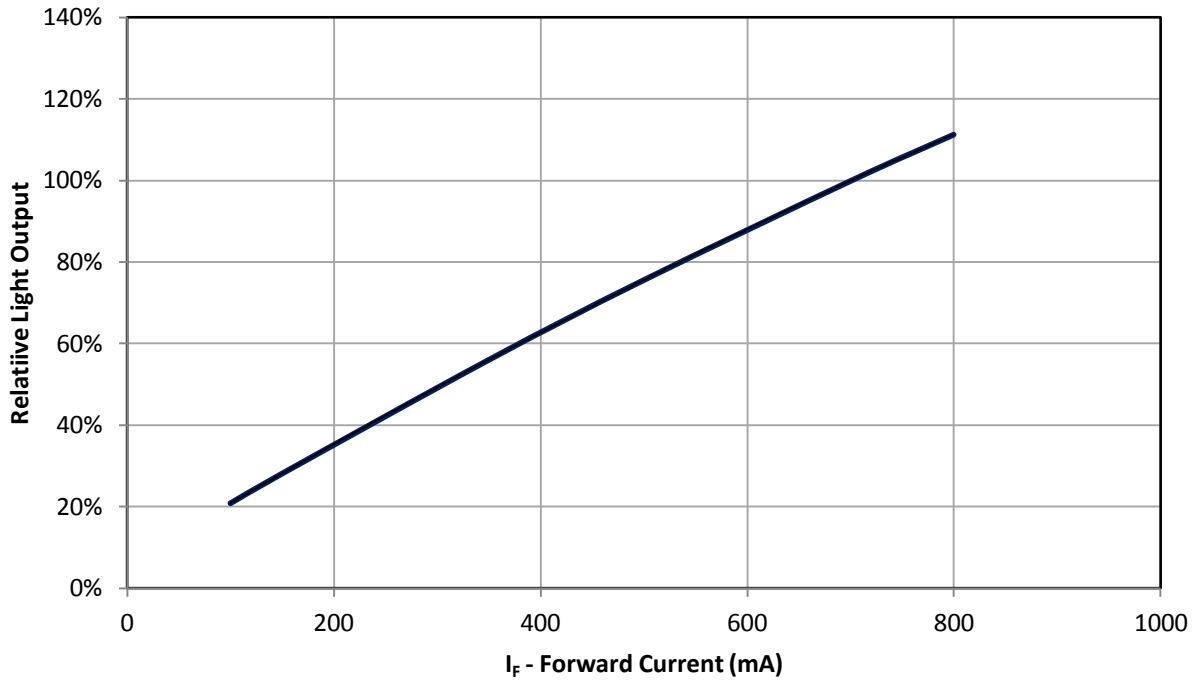

Figure 7: Typical relative light output vs. forward current @  $T_c = 25^\circ\text{C}$ .

### Typical Normalized Radiant Flux over Temperature

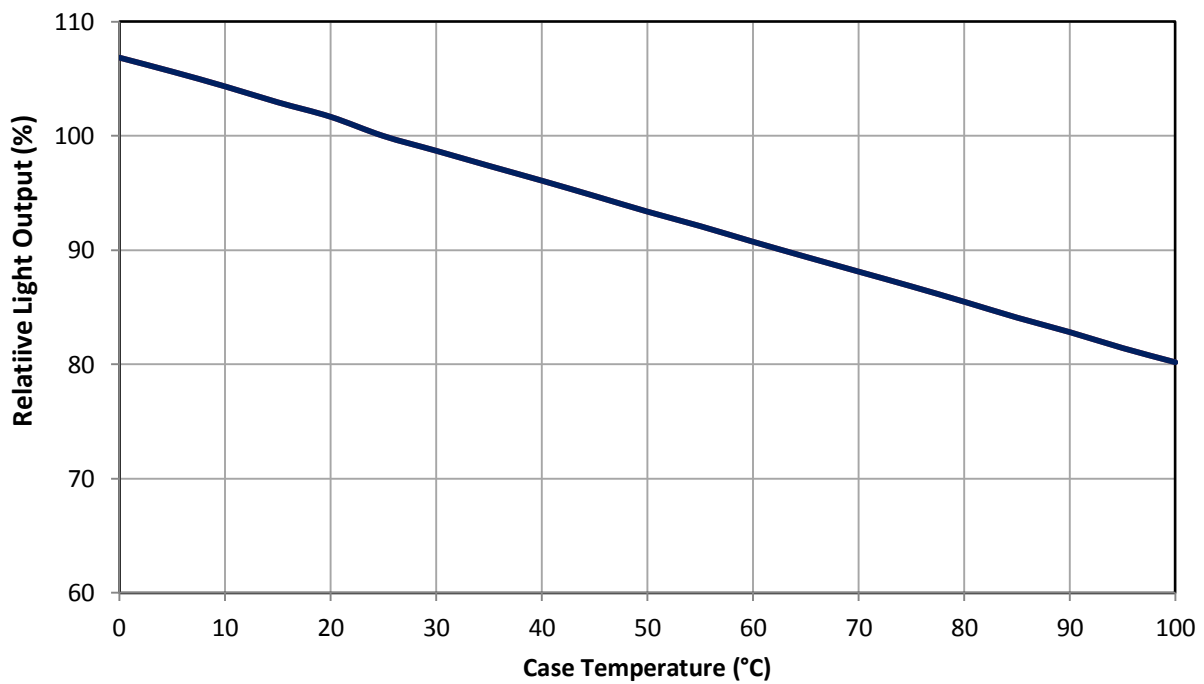

Figure 8: Typical relative light output vs. case temperature.

## Typical Forward Voltage Characteristics per String

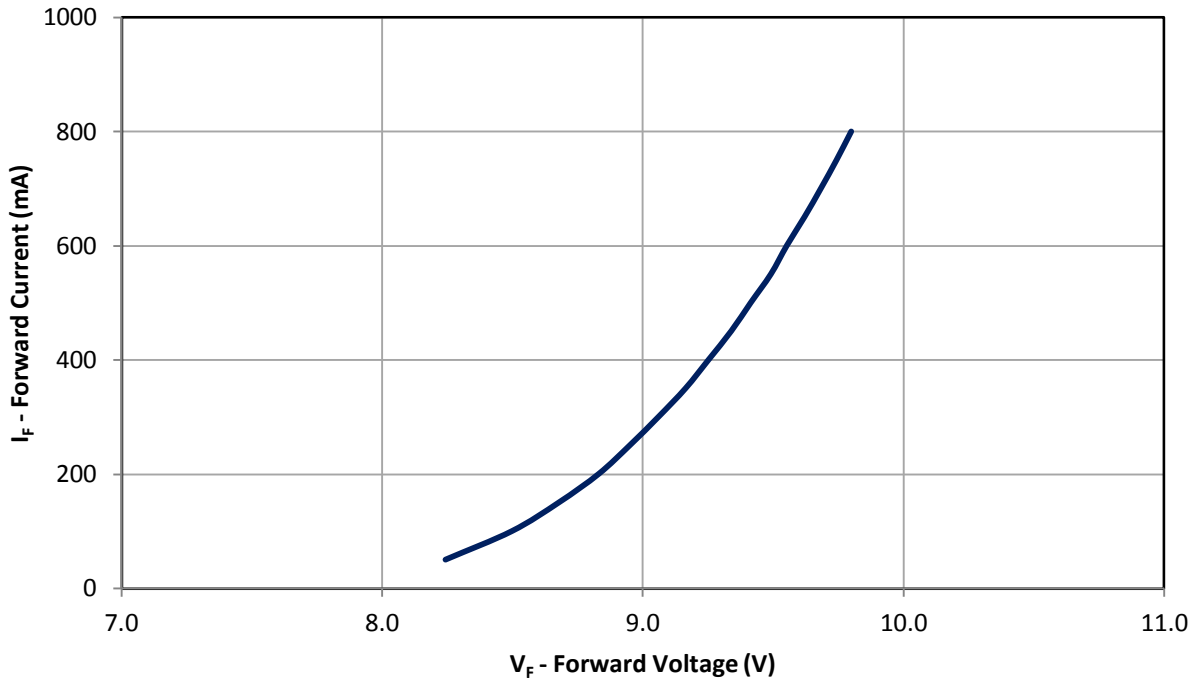

Figure 9: Typical forward current vs. forward voltage<sup>1</sup> @  $T_c = 25^\circ\text{C}$ .

Note for Figure 9:

1. Forward Voltage per string of 3 LED dies connected in series.

## Current De-rating

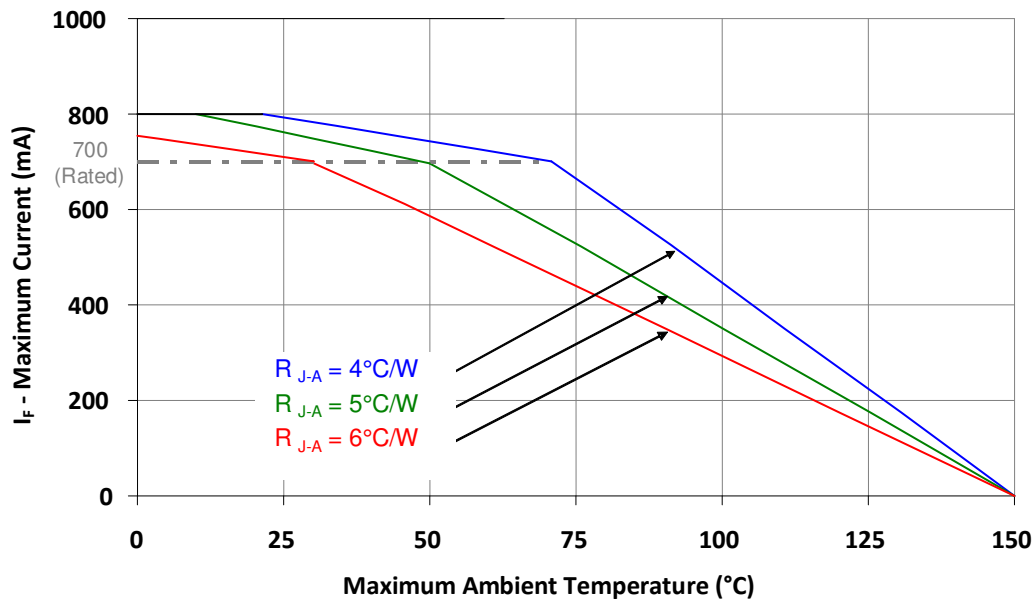

Figure 10: Maximum forward current vs. ambient temperature based on  $T_{j(\text{MAX})} = 150^\circ\text{C}$ .

Notes for Figure 10:

1. Maximum current assumes that all 9 LED dice are operating concurrently at the same current.
2.  $RO_{j-c}$  [Junction to Case Thermal Resistance] for the LZ9-00SW00 is typically  $1.3^\circ\text{C/W}$ .
3.  $RO_{j-a}$  [Junction to Ambient Thermal Resistance] =  $RO_{j-c} + RO_{c-a}$  [Case to Ambient Thermal Resistance].



## Emitter Tape and Reel Specifications (mm)

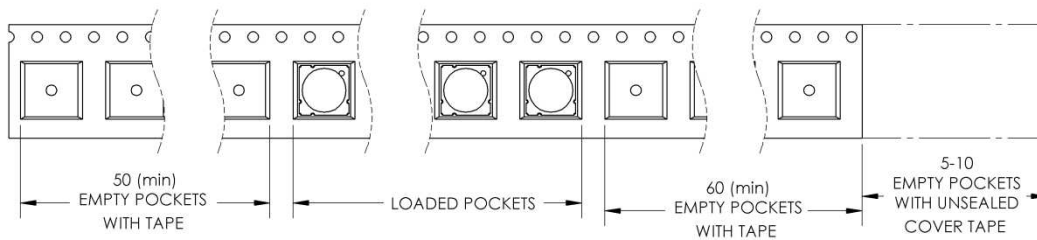
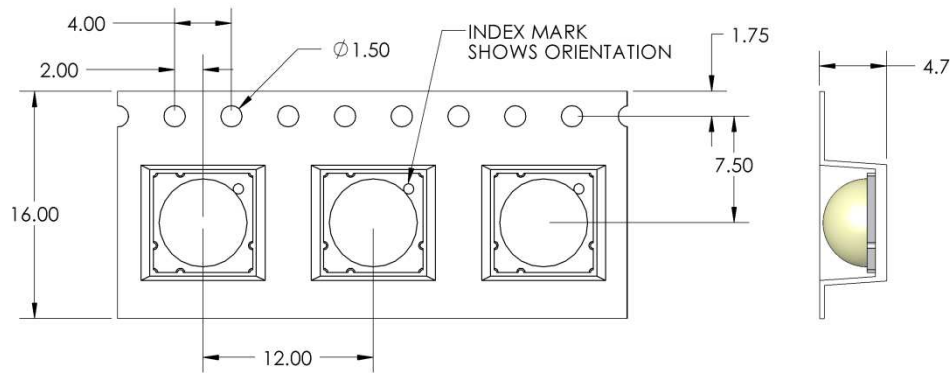

Figure 11: Emitter carrier tape specifications (mm).

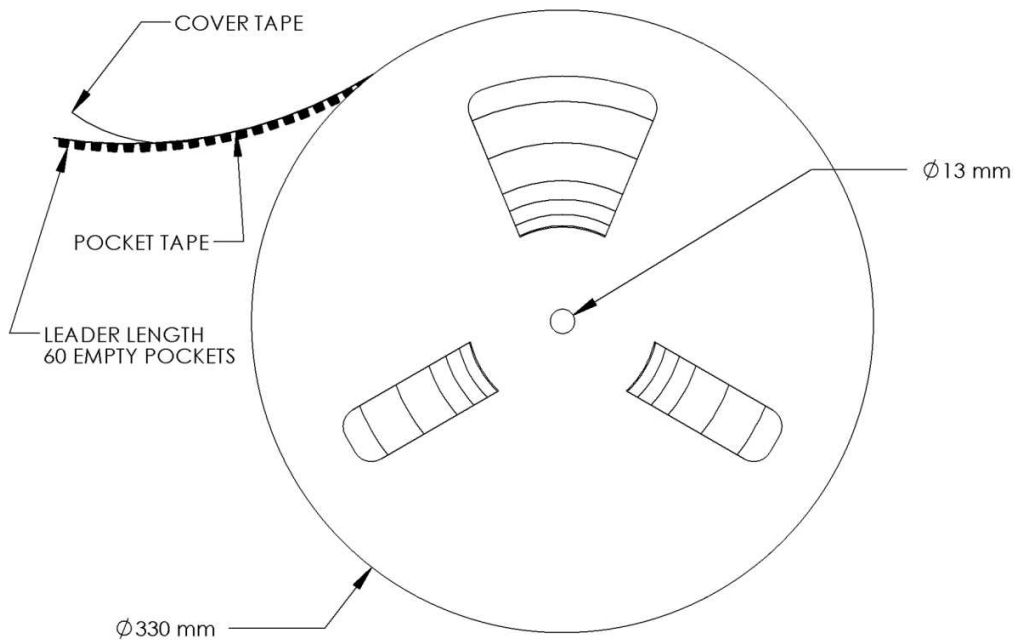

Figure 12: Emitter Reel specifications (mm).

# LZ9 MCPCB Family

Part number	Type of MCPCB	Diameter (mm)	Emitter + MCPCB Thermal Resistance (°C/W)	Typical $V_f$ (V)	Typical $I_f$ (mA)
LZ9-Jxxxxx	1-channel	19.9	$1.3 + 0.2 = 1.5$	29.1	700
LZ9-Mxxxxx	3-channel	19.9	$1.3 + 0.2 = 1.5$	9.7/ ch	700/ ch

## Mechanical Mounting of MCPCB

- MCPCB bending should be avoided as it will cause mechanical stress on the emitter, which could lead to substrate cracking and subsequently LED dies cracking.
- To avoid MCPCB bending:
  - Special attention needs to be paid to the flatness of the heat sink surface and the torque on the screws.
  - Care must be taken when securing the board to the heat sink. This can be done by tightening three M3 screws (or #4-40) in steps and not all the way through at once. Using fewer than three screws will increase the likelihood of board bending.
  - It is recommended to always use plastics washers in combinations with the three screws.
  - If non-taped holes are used with self-tapping screws, it is advised to back out the screws slightly after tightening (with controlled torque) and then re-tighten the screws again.

## Thermal interface material

- To properly transfer heat from LED emitter to heat sink, a thermally conductive material is required when mounting the MCPCB on to the heat sink.
- There are several varieties of such material: thermal paste, thermal pads, phase change materials and thermal epoxies. An example of such material is Electrolube EHTC.
- It is critical to verify the material's thermal resistance to be sufficient for the selected emitter and its operating conditions.

## Wire soldering

- To ease soldering wire to MCPCB process, it is advised to preheat the MCPCB on a hot plate of 125-150°C. Subsequently, apply the solder and additional heat from the solder iron will initiate a good solder reflow. It is recommended to use a solder iron of more than 60W.
- It is advised to use lead-free, no-clean solder. For example: SN-96.5 AG-3.0 CU 0.5 #58/275 from Kester (pn: 24-7068-7601)

# LZ9-Jxxxxx

## 1 channel, Standard Star MCPCB (1x9) Dimensions (mm)

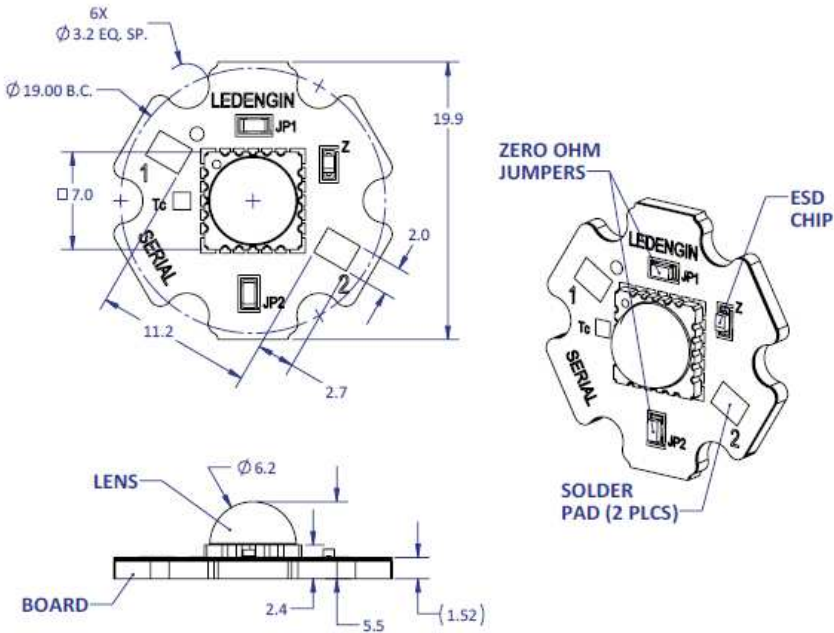

### Notes:

- Unless otherwise noted, the tolerance =  $\pm 0.2$  mm.
- Slots in MCPCB are for M3 or #4-40 mounting screws.
- LED Engin recommends plastic washers to electrically insulate screws from solder pads and electrical traces.
- LED Engin recommends using thermal interface material when attaching the MCPCB to a heatsink.
- The thermal resistance of the MCPCB is:  $\theta_{JC-B} 0.2^{\circ}\text{C}/\text{W}$ . This low thermal resistance is possible by utilizing a copper based MCPCB with pedestal design. The emitter thermal slug is in direct contact with the copper core. There are several vendors that offer similar solutions, some of them are: Rayben, Bergquist, SinkPad, Bridge-Semiconductor.

## Components used

MCPCB: MHE-301 copper (Rayben)  
 ESD chips: BZX585-C47 (NXP, for 9 LED die)  
 Jumpers: CRCW06030000Z0 (Vishay)

Pad layout			
Ch.	MCPCB Pad	String/die	Function
1	1	1/ABCDEF	Cathode -
	2	GHI	Anode +

# LZ9-Mxxxxx

## 3 channel, Standard Star MCPCB (3x3) Dimensions (mm)

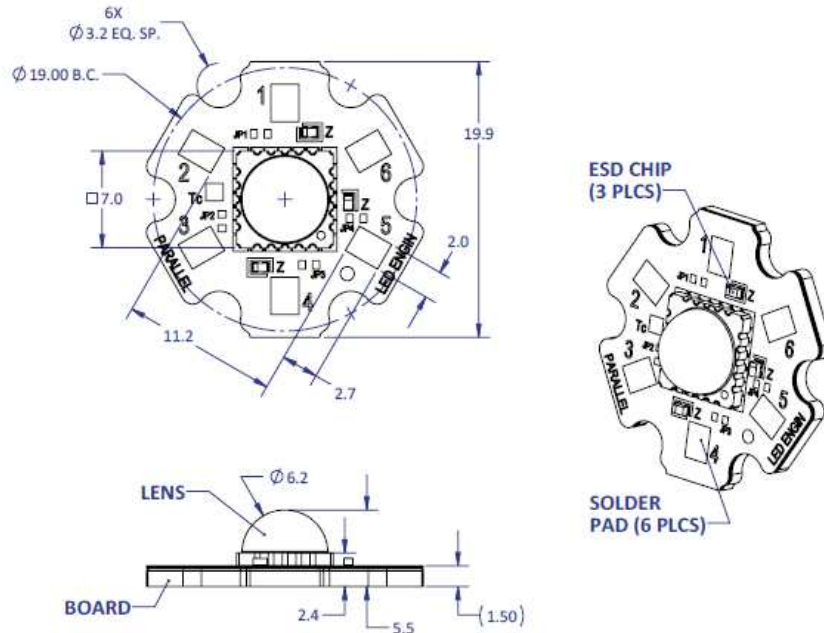

**Notes:**

- Unless otherwise noted, the tolerance =  $\pm 0.2$  mm.
- Slots in MCPCB are for M3 or #4-40 mounting screws.
- LED Engin recommends plastic washers to electrically insulate screws from solder pads and electrical traces.
- LED Engin recommends using thermal interface material when attaching the MCPCB to a heatsink.
- The thermal resistance of the MCPCB is:  $\theta_{JC-B} 0.2^{\circ}\text{C/W}$ . This low thermal resistance is possible by utilizing a copper based MCPCB with pedestal design. The emitter thermal slug is in direct contact with the copper core. There are several vendors that offer similar solutions, some of them are: Rayben, Bergquist, SinkPad, Bridge-Semiconductor.

## Components used

MCPCB: MHE-301 copper (Rayben)  
 ESD chips: BZX884-C18 (NXP, for 3 LED die)

Pad layout			
Ch.	MCPCB Pad	String/die	Function
1	4	1/ABE	Cathode -
	3		Anode +
2	5	2/CGI	Cathode -
	2		Anode +
3	6	3/DFH	Cathode -
	1		Anode +

**LZ9 secondary TIR optics family**

# LLxx-3T06-H

**Optical Specification**

Part number <sup>1</sup>	Beam angle <sup>2</sup>	Field angle <sup>3</sup>	Optical efficiency <sup>4</sup>	On-axis intensity <sup>5</sup>
	degrees	degrees	%	cd/lm
<b>LLSP-3T06-H</b>	17	36	90	5.4
<b>LLNF-3T06-H</b>	26	49	90	2.2
<b>LLFL-3T06-H</b>	39	83	90	1.2

**Notes:**

1. Lenses can also be ordered without the holder. Replace –H with –O for this option.
2. Beam angle is defined as the full width at 50% of the max intensity (FWHM).
3. Field angle is defined as the full width at 10% of the max intensity.
4. Optical efficiency is defined as the ratio between the incoming flux and the outgoing flux.
5. On-axis intensity is defined as the ratio between the total input lumen and the intensity in the optical center of the lens.



## Typical Relative Intensity over Angle

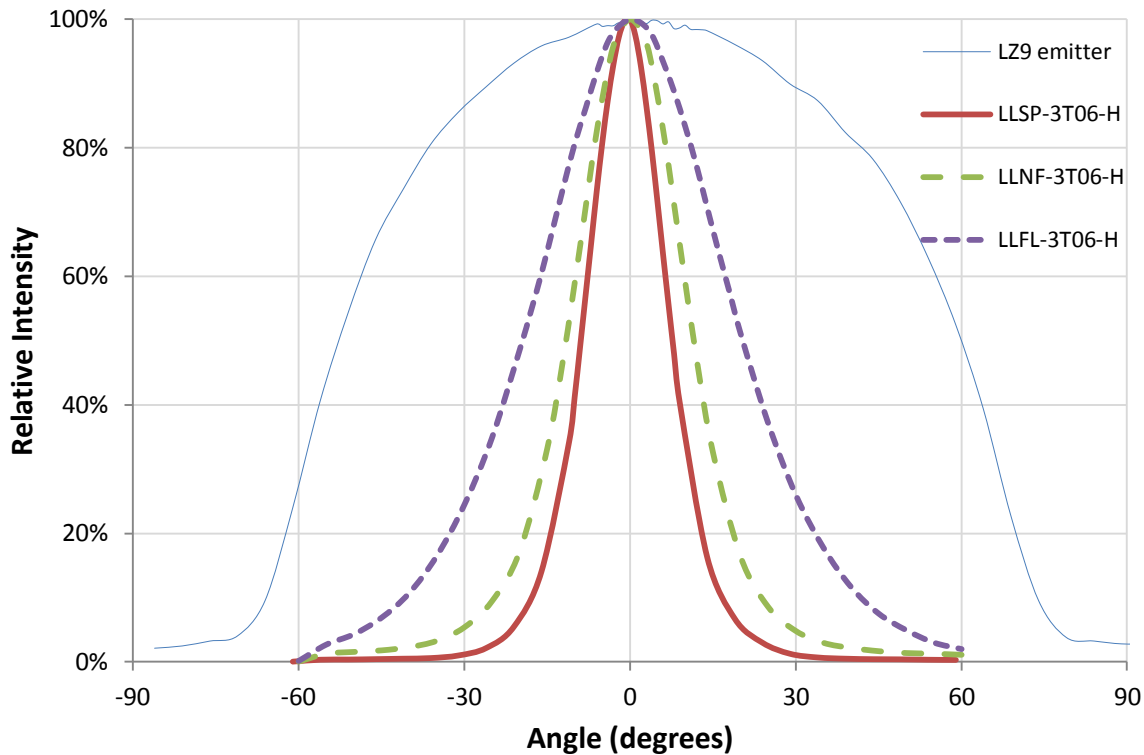

## General Characteristics

	Symbol	Value	Rating	Unit
<b>Mechanical</b>				
Height from Seating Plane		19.2	Typical	mm
Diameter		38.9	Typical	mm
<b>Material</b>				
Lens		PMMA		
Holder		Polycarbonate		
<b>Optical</b>				
Transmission <sup>1</sup> (>90%)	$\lambda$	410-1100	Min-Max.	nm
<b>Environmental</b>				
Storage Temperature	$T_{stg}$	-40 ~ +110	Min-Max.	°C
Operating Temperature	$T_{sol}$	-40 ~ +110	Min-Max.	°C

Notes:

1. It is not recommended to use a UV emitter with this lens due to lower transmission at wavelengths < 410nm.

## Mechanical dimensions

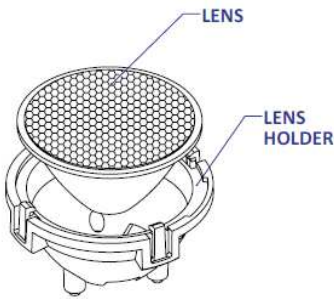

### Lens with Holder

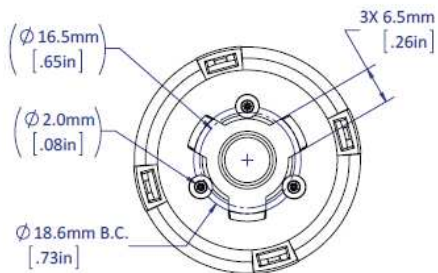
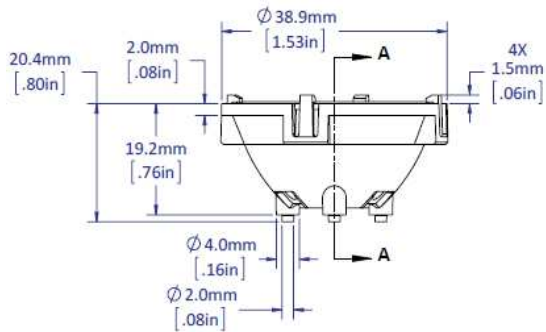

### Lens

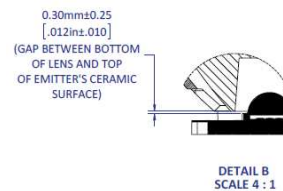
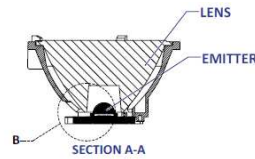
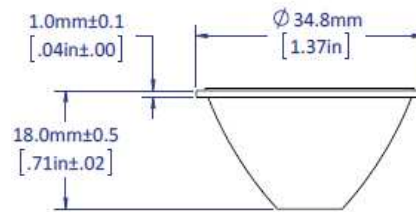

## Company Information

LED Engin, based in California's Silicon Valley, develops, manufactures, and sells advanced LED emitters, optics and light engines to create uncompromised lighting experiences for a wide range of entertainment, architectural, general lighting and specialty applications. LuxiGen™ multi-die emitter and secondary lens combinations reliably deliver industry-leading flux density, upwards of 5000 quality lumens to a target, in a wide spectrum of colors including whites, tunable whites, multi-color and UV LEDs in a unique patented compact ceramic package. Our LuxiTune™ series of tunable white lighting modules leverage our LuxiGen emitters and lenses to deliver quality, control, freedom and high density tunable white light solutions for a broad range of new recessed and downlighting applications. The small size, yet remarkably powerful beam output and superior in-source color mixing, allows for a previously unobtainable freedom of design wherever high-flux density, directional light is required.

LED Engin is committed to providing products that conserve natural resources and reduce greenhouse emissions.

LED Engin reserves the right to make changes to improve performance without notice.

Please contact [sales@ledengin.com](mailto:sales@ledengin.com) or (408) 922-7200 for more information.