



Chipsmall Limited consists of a professional team with an average of over 10 year of expertise in the distribution of electronic components. Based in Hongkong, we have already established firm and mutual-benefit business relationships with customers from,Europe,America and south Asia,supplying obsolete and hard-to-find components to meet their specific needs.

With the principle of “Quality Parts,Customers Priority,Honest Operation,and Considerate Service”,our business mainly focus on the distribution of electronic components. Line cards we deal with include Microchip,ALPS,ROHM,Xilinx,Pulse,ON,Everlight and Freescale. Main products comprise IC,Modules,Potentiometer,IC Socket,Relay,Connector.Our parts cover such applications as commercial,industrial, and automotives areas.

We are looking forward to setting up business relationship with you and hope to provide you with the best service and solution. Let us make a better world for our industry!



Contact us

Tel: +86-755-8981 8866 Fax: +86-755-8427 6832

Email & Skype: info@chipsmall.com Web: www.chipsmall.com

Address: A1208, Overseas Decoration Building, #122 Zhenhua RD., Futian, Shenzhen, China



High Luminous Efficacy
RGB LED Emitter

LZC-03MC00



Key Features

- Ultra-bright, Ultra-compact 40W RGB LED
- Full spectrum of brilliant colors with superior color mixing
- Small high density foot print – 9.0mm x 9.0mm
- Surface mount ceramic package with integrated glass lens
- Exceptionally low Thermal Resistance (0.7°C/W)
- Electrically neutral thermal path
- Extreme Luminous Flux density
- JEDEC Level 1 for Moisture Sensitivity Level
- Lead (Pb) free and RoHS compliant
- Reflow solderable (up to 6 cycles)
- Emitter available on 3-channel MCPCB (optional)
- Recommended use with LL-3T08 family of High Efficiency / High Uniformity color-mixing lenses for perfect color uniformity from 8 to 32 deg.

Typical Applications

- Architectural Lighting
- Entertainment
- Stage and Studio Lighting
- Accent Lighting

Description

The LZC-03MC00 RGB LED emitter enables a full spectrum of brilliant colors with the highest light output, highest flux density, and superior color mixing available. It outperforms other colored lighting solutions with multiple red, green and blue LED die in a single, compact emitter. With 40W power capability and a 9.0mm x 9.0mm ultra-small footprint, this package provides exceptional luminous flux density. LED Engin's RGB LED offers ultimate design flexibility with three individually addressable color channels. The patented design with thermally and electrically isolated pads has unparalleled thermal and optical performance. The high quality materials used in the package are chosen to optimize light output and minimize stresses which results in monumental reliability and lumen maintenance. The robust product design thrives in outdoor applications with high ambient temperatures and high humidity.

LZC-03MC00 (5.2-3/12/13)

Part Number Options

Base part number

Part number	Description
LZC-03MC00-xxxx	LZC emitter
LZC-83MC00-xxxx	LZC emitter on 3 channel 3x4 Star MCPCB

Notes:

1. See "Part Number Nomenclature" for full overview on LED Engin part number nomenclature.

Bin Kit Option Codes

MC, Red-Green-Blue (RGB)			
Kit number suffix	Min flux Bin	Color Bin Range	Description
0000	02R	R2 – R2	Red full distribution flux; full distribution wavelength
	07G	G2 – G3	Green full distribution flux; full distribution wavelength
	07B	B01 – B02	Blue full distribution flux; full distribution wavelength

Notes:

Default bin kit option is -0000

Luminous Flux Bins

Table 1:

Bin Code	Minimum Luminous Flux (Φ_V) @ $I_F = 700\text{mA}$ ^[1,2] (lm)			Maximum Luminous Flux (Φ_V) @ $I_F = 700\text{mA}$ ^[1,2] (lm)		
	4 Red	4 Green	4 Blue	4 Red	4 Green	4 Blue
	02R	240			400	
07G		330			520	
07B			64			103
08B			103			175

Notes for Table 1:

- Luminous flux performance guaranteed within published operating conditions. LED Engin maintains a tolerance of $\pm 10\%$ on flux measurements.
- Each color consists of 4 die in series for binning purposes.

Dominant Wavelength Bins

Table 2:

Bin Code	Minimum Dominant Wavelength (λ_D) @ $I_F = 700\text{mA}$ ^[1,2] (nm)			Maximum Dominant Wavelength (λ_D) @ $I_F = 700\text{mA}$ ^[1,2] (nm)		
	1 Red	2 Green ^[2]	1 Blue	1 Red	2 Green ^[2]	1 Blue
	R2	618			630	
G2		520			525	
G3		525			530	
B01			452			457
B02			457			462

Notes for Table 2:

- LED Engin maintains a tolerance of $\pm 1.0\text{nm}$ on dominant wavelength measurements.
- Green LEDs are binned for dominant wavelength @ $I_F = 350\text{mA}$. Refer to Figure 6 for typical dominant wavelength shift over forward current.

Forward Voltage Bin

Table 3:

Bin Code	Minimum Forward Voltage (V_F) @ $I_F = 700\text{mA}$ ^[1,2] (V)			Maximum Forward Voltage (V_F) @ $I_F = 700\text{mA}$ ^[1,2] (V)		
	4 Red	4 Green	4 Blue	4 Red	4 Green	4 Blue
	0	8.00	12.80	12.80	11.84	17.20

Notes for Table 3:

- Forward Voltage is binned with all four LED dice connected in series.
- LED Engin maintains a tolerance of $\pm 0.16\text{V}$ for forward voltage measurements for the four LEDs.

Absolute Maximum Ratings

Table 4:

Parameter	Symbol	Value	Unit
DC Forward Current ^[1]	I_F	1000	mA
Peak Pulsed Forward Current ^[2]	I_{FP}	1500	mA
Reverse Voltage	V_R	See Note 3	V
Storage Temperature	T_{stg}	-40 ~ +150	°C
Junction Temperature [Blue, Green]	T_J	150	°C
Junction Temperature [Red]	T_J	125	°C
Soldering Temperature ^[4]	T_{sol}	260	°C
Allowable Reflow Cycles		6	
ESD Sensitivity ^[5]		> 8,000 V HBM Class 3B JESD22-A114-D	

Notes for Table 4:

- Maximum DC forward current is determined by the overall thermal resistance and ambient temperature. Follow the curves in Figure 11 for current derating.
- Pulse forward current conditions: Pulse Width ≤ 10msec and Duty Cycle ≤ 10%.
- LEDs are not designed to be reverse biased.
- Solder conditions per JEDEC 020D. See Reflow Soldering Profile Figure 5.
- LED Engin recommends taking reasonable precautions towards possible ESD damages and handling the LZC-03MC00 in an electrostatic protected area (EPA). An EPA may be adequately protected by ESD controls as outlined in ANSI/ESD S6.1.

Optical Characteristics @ $T_C = 25^\circ\text{C}$

Table 5:

Parameter	Symbol	Typical			Unit
		Red	Green	Blue ^[1]	
Luminous Flux (@ $I_F = 700\text{mA}$)	Φ_V	280	455	100	lm
Luminous Flux (@ $I_F = 1000\text{mA}$)	Φ_V	360	590	130	lm
Dominant Wavelength	λ_D	623	523	460	nm
Viewing Angle ^[2]	$2\Theta_{\frac{1}{2}}$		95		Degrees
Total Included Angle ^[3]	$\Theta_{0.9}$		115		Degrees

Notes for Table 5:

- When operating the Blue LED, observe IEC 60825-1 class 2 rating. Do not stare into the beam.
- Viewing Angle is the off axis angle from emitter centerline where the luminous intensity is $\frac{1}{2}$ of the peak value.
- Total Included Angle is the total angle that includes 90% of the total luminous flux.

Electrical Characteristics @ $T_C = 25^\circ\text{C}$

Table 6:

Parameter	Symbol	Typical			Unit
		4 Red	4 Green	4 Blue	
Forward Voltage (@ $I_F = 700\text{mA}$)	V_F	9.4	16.8	14.0	V
Forward Voltage (@ $I_F = 1000\text{mA}$)	V_F	10.2	18.0	14.6	V
Temperature Coefficient of Forward Voltage	$\Delta V_F / \Delta T_J$	-7.6	-11.6	-12.0	mV/°C
Thermal Resistance (Junction to Case)	RO_{J-C}		0.7		°C/W

Note for Table 6:

- Forward Voltage typical value is for all four LED dice from the same color connected in series.

Average Lumen Maintenance Projections

Lumen maintenance generally describes the ability of a lamp to retain its output over time. The useful lifetime for solid state lighting devices (Power LEDs) is also defined as Lumen Maintenance, with the percentage of the original light output remaining at a defined time period.

Based on long-term WHTOL testing, LED Engin projects that the LZ Series will deliver, on average, 70% Lumen Maintenance at 65,000 hours of operation at a forward current of 700 mA. This projection is based on constant current operation with junction temperature maintained at or below 125°C.

IPC/JEDEC Moisture Sensitivity Level

Table 7 - IPC/JEDEC J-STD-20D.1 MSL Classification:

Level	Soak Requirements					
	Floor Life		Standard		Accelerated	
	Time	Conditions	Time (hrs)	Conditions	Time (hrs)	Conditions
1	Unlimited	≤ 30°C/ 85% RH	168 +5/-0	85°C/ 85% RH	n/a	n/a

Notes for Table 7:

1. The standard soak time includes a default value of 24 hours for semiconductor manufacturer's exposure time (MET) between bake and bag and includes the maximum time allowed out of the bag at the distributor's facility.

Mechanical Dimensions (mm)

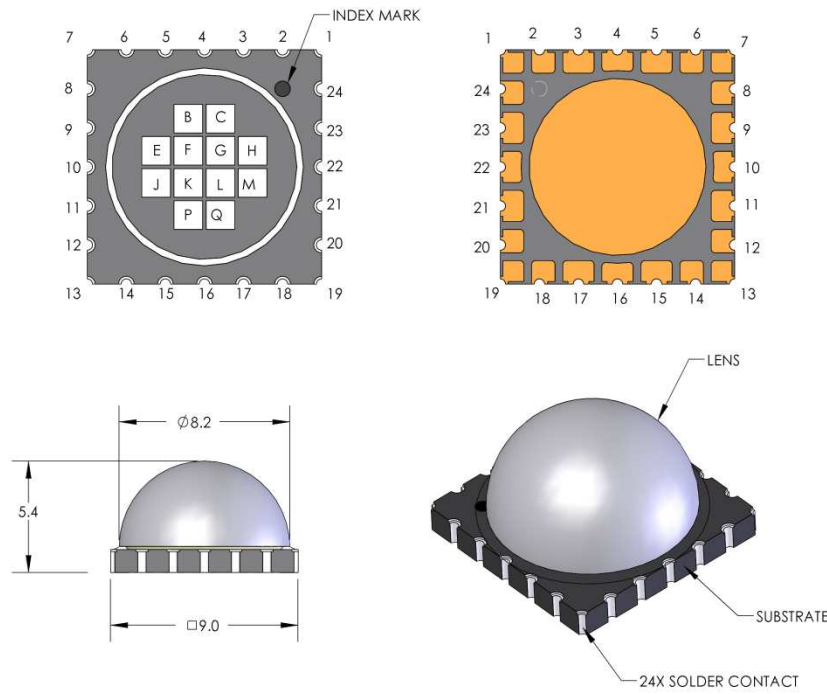

Pin Out			
Pin	Die	Color	Polarity
3	C	Red	Anode +
4	C	Red	Cathode -
9	E	Red	Anode +
10	E	Red	Cathode -
21	M	Red	Anode +
22	M	Red	Cathode -
15	P	Red	Anode +
16	P	Red	Cathode -
5	B	Green	Cathode -
6	B	Green	Anode +
23	H	Green	Cathode -
24	H	Green	Anode +
11	J	Green	Cathode -
12	J	Green	Anode +
17	Q	Green	Cathode -
18	Q	Green	Anode +
2	G	Blue	Anode +
7	G	Blue	na
7	F	Blue	na
13	F	Blue	na
13	K	Blue	na
19	K	Blue	na
19	L	Blue	na
20	L	Blue	Cathode -

Figure 1: Package Outline Drawing

Note for Figure 1:

- Unless otherwise noted, the tolerance = ± 0.20 mm.

Recommended Solder Pad Layout (mm)

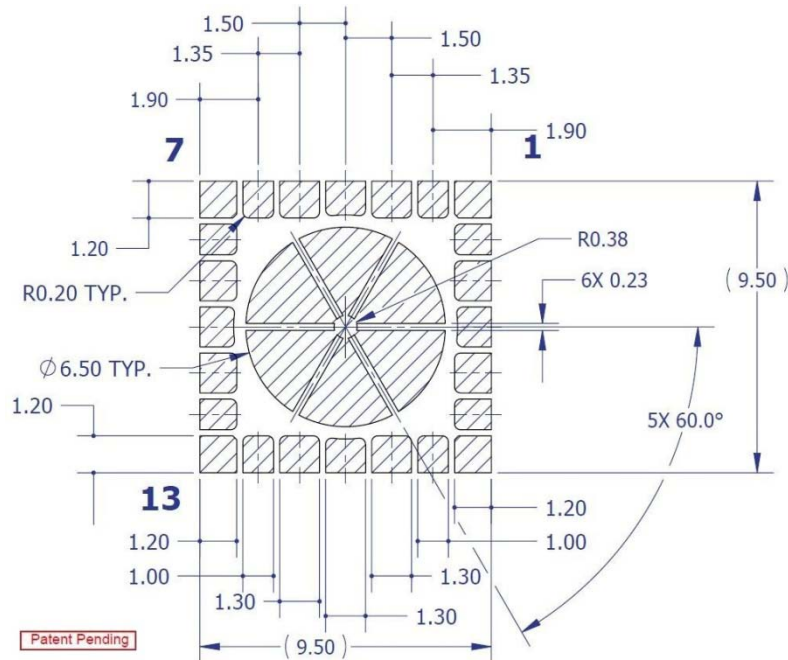

Figure 2a: Recommended solder pad layout for anode, cathode, and thermal pad.

Note for Figure 2a:

- Unless otherwise noted, the tolerance = ± 0.20 mm.

Recommended Solder Mask Layout (mm)

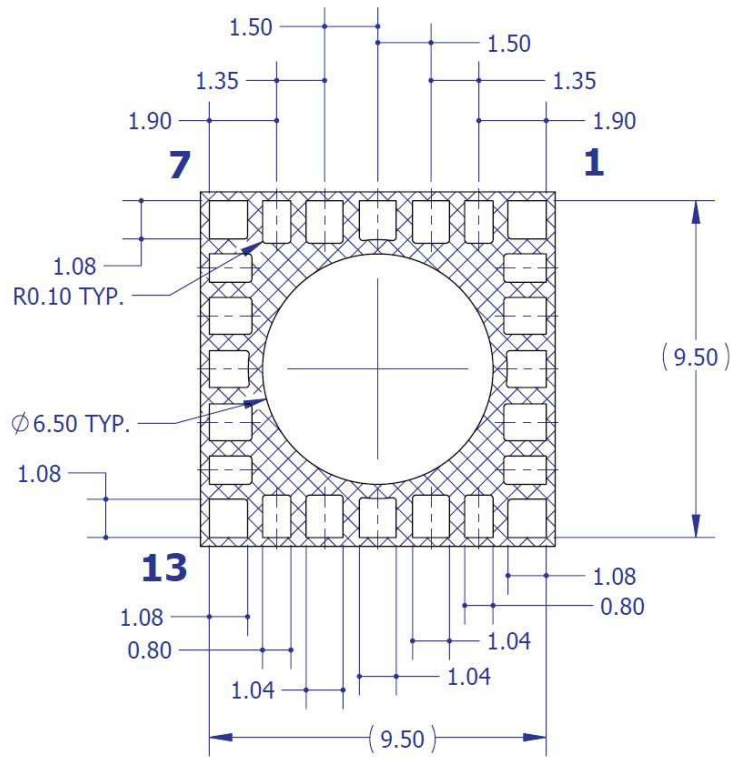

Figure 2b: Recommended solder mask opening (hatched area) for anode, cathode, and thermal pad.

Note for Figure 2b:

- 1. Unless otherwise noted, the tolerance = ± 0.20 mm.

Reflow Soldering Profile

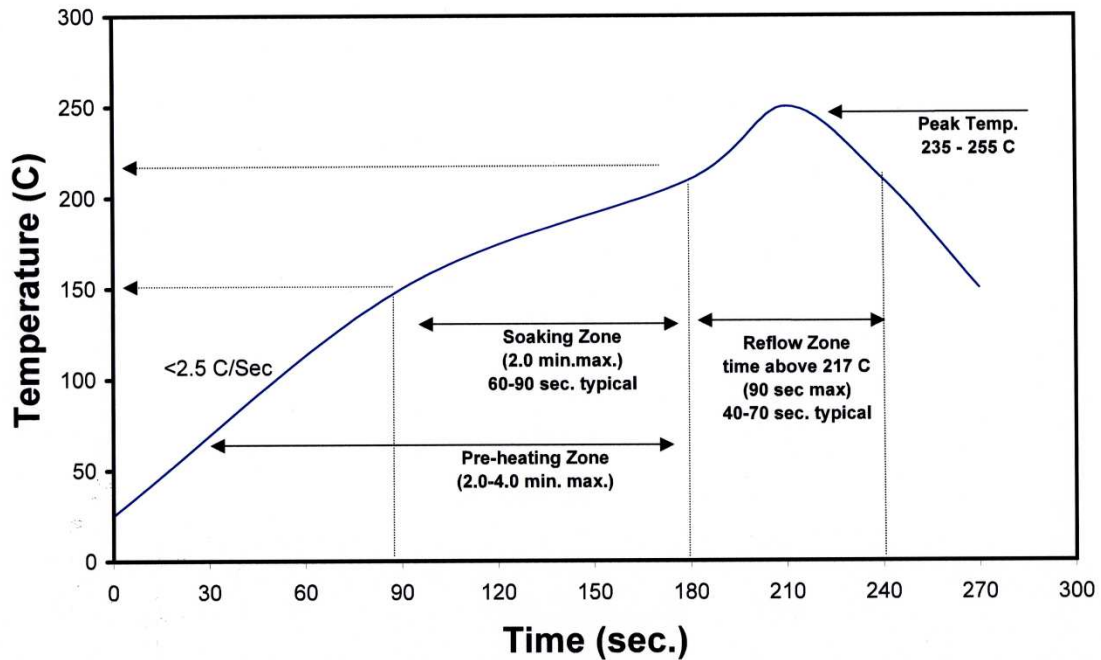

Figure 3: Reflow soldering profile for lead free soldering.

Typical Radiation Pattern

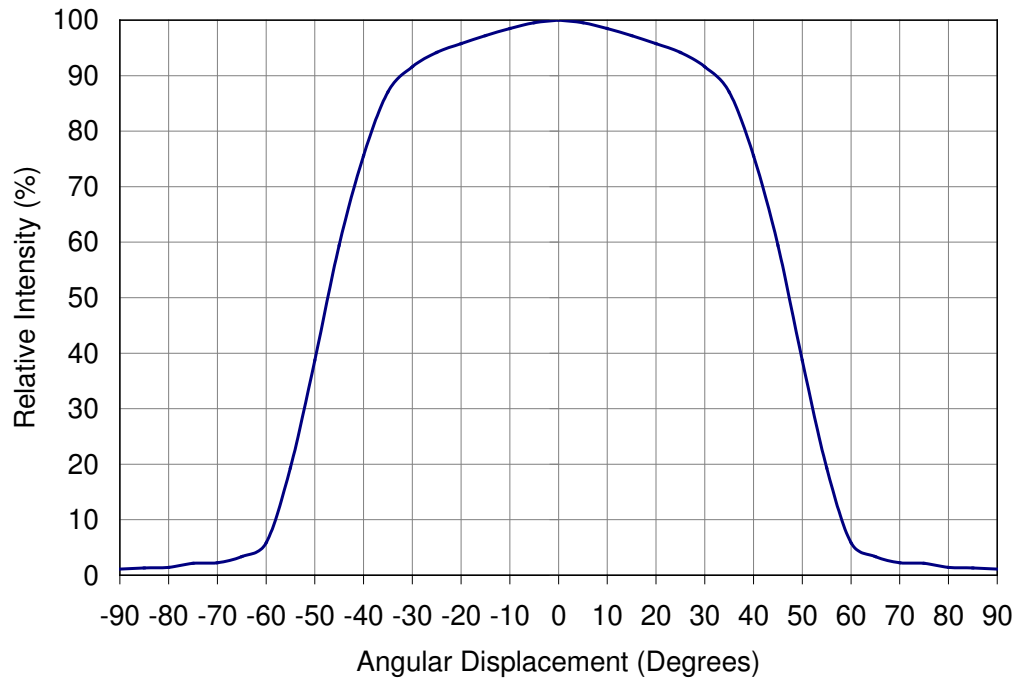

Figure 4: Typical representative spatial radiation pattern.

Typical Relative Spectral Power Distribution

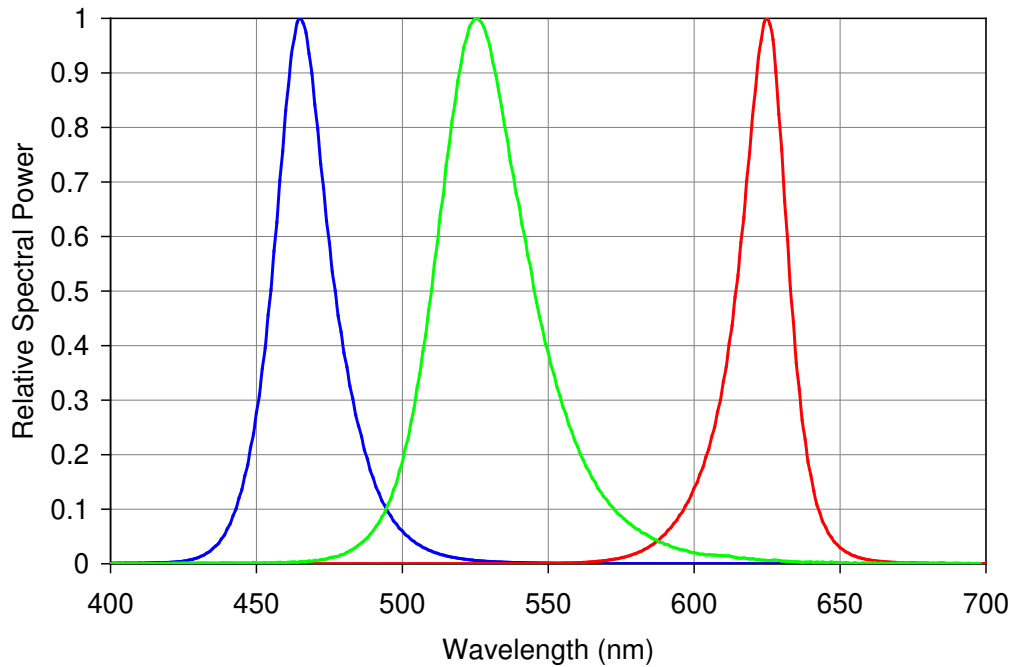

Figure 5: Typical relative spectral power vs. wavelength @ T_c = 25°C.

Typical Dominant Wavelength Shift over Forward Current

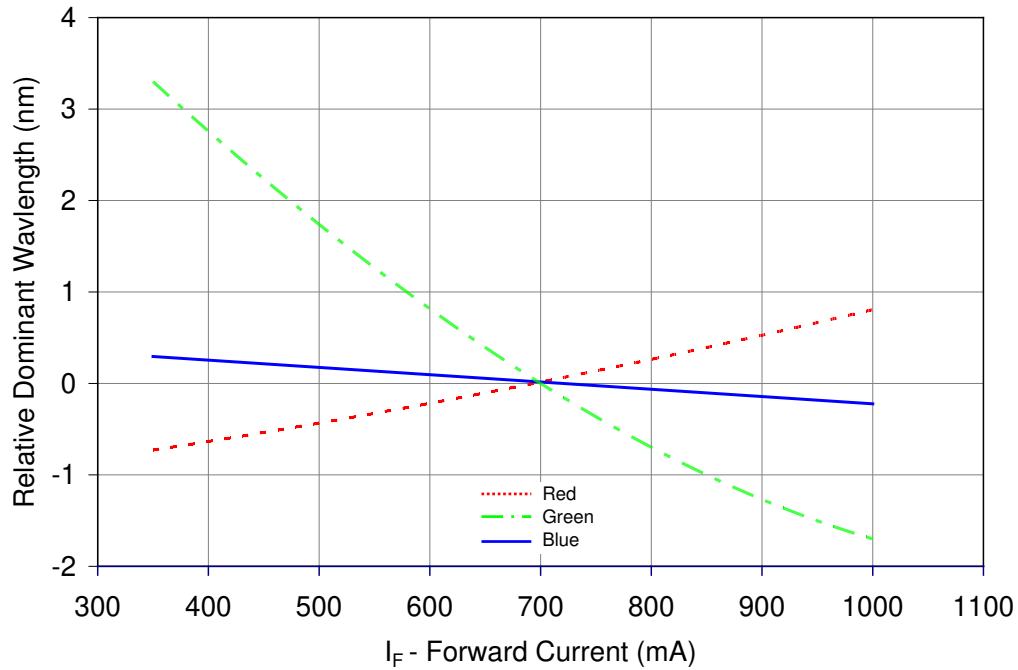

Figure 6: Typical dominant wavelength shift vs. forward current @ T_c = 25°C.

Dominant Wavelength Shift over Temperature

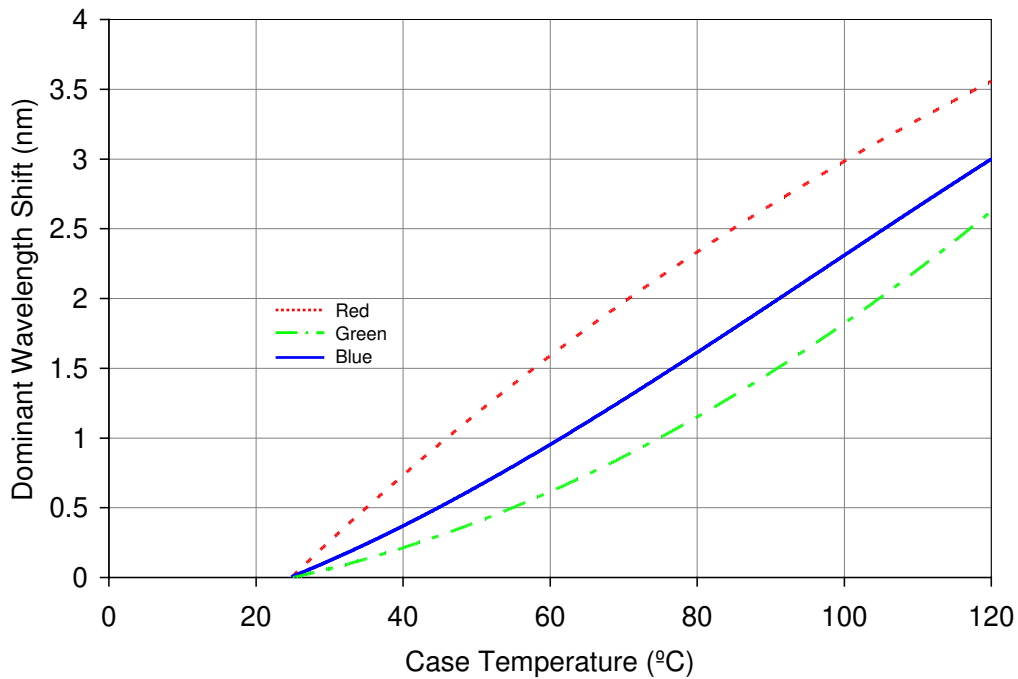

Figure 7: Typical dominant wavelength shift vs. case temperature.

Typical Relative Light Output

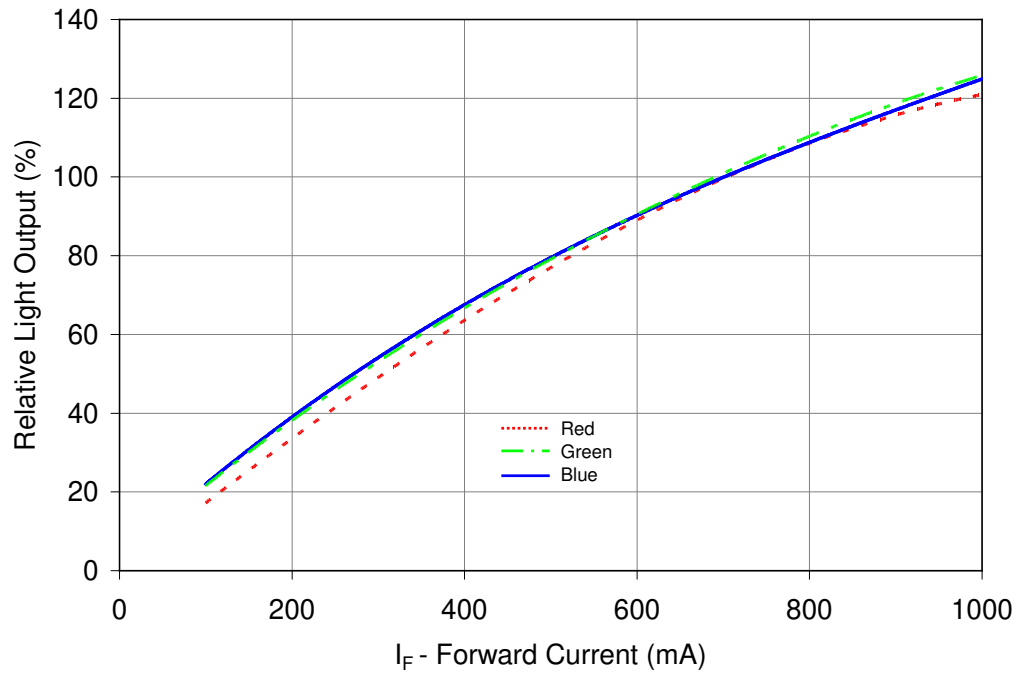

Figure 8: Typical relative light output vs. forward current @ $T_c = 25^\circ\text{C}$.

Typical Relative Light Output over Temperature

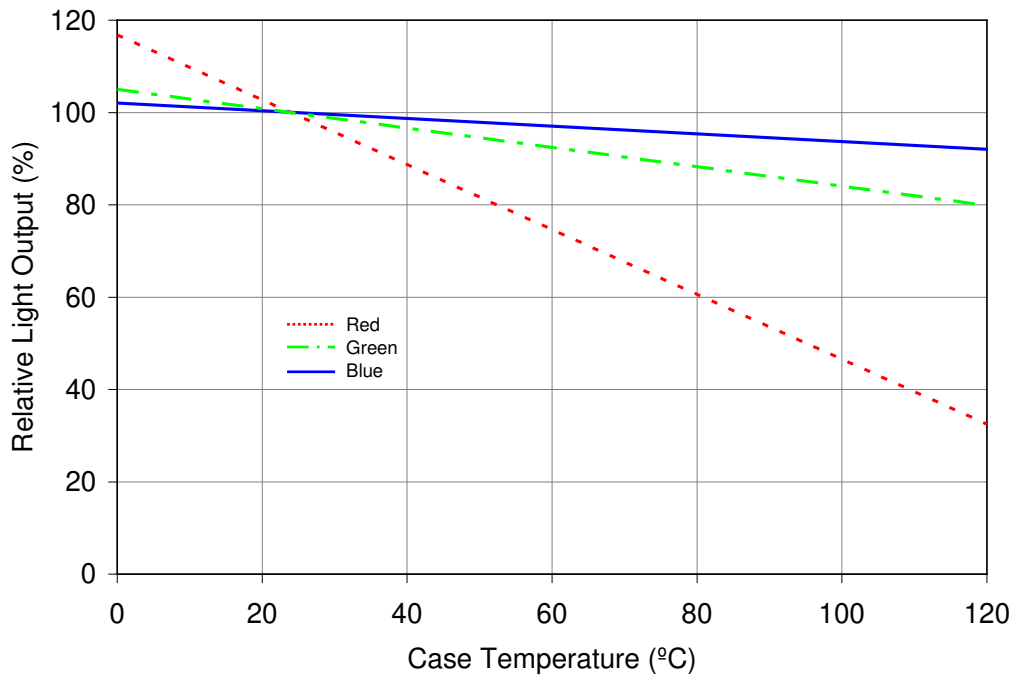

Figure 9: Typical relative light output vs. case temperature.

Typical Forward Current Characteristics

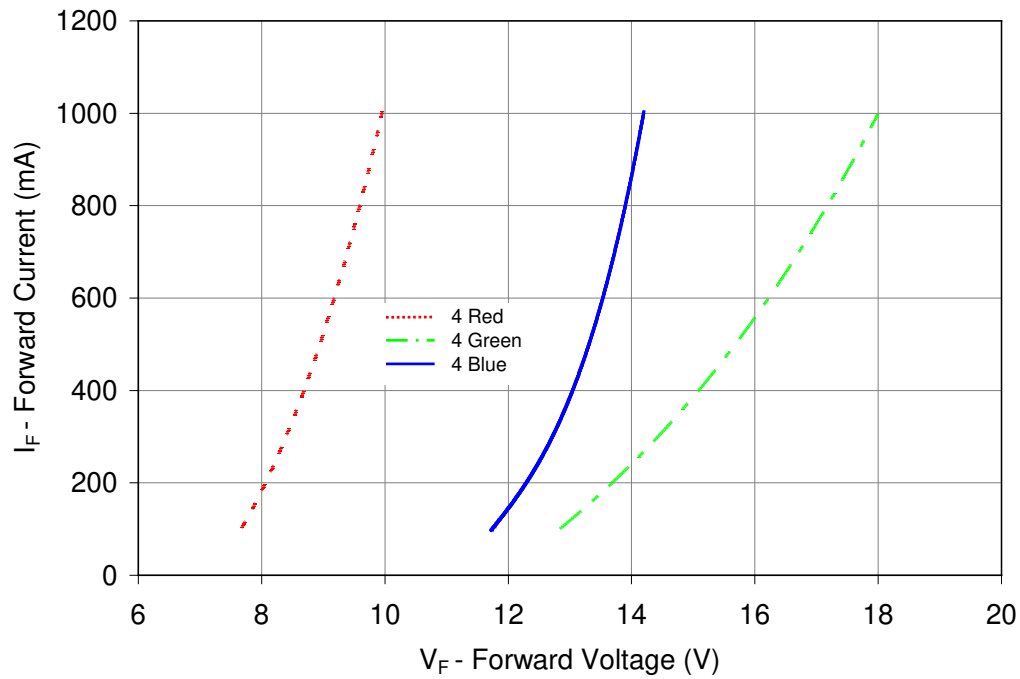

Figure 10: Typical forward current vs. forward voltage @ $T_c = 25^\circ\text{C}$.

Current De-rating

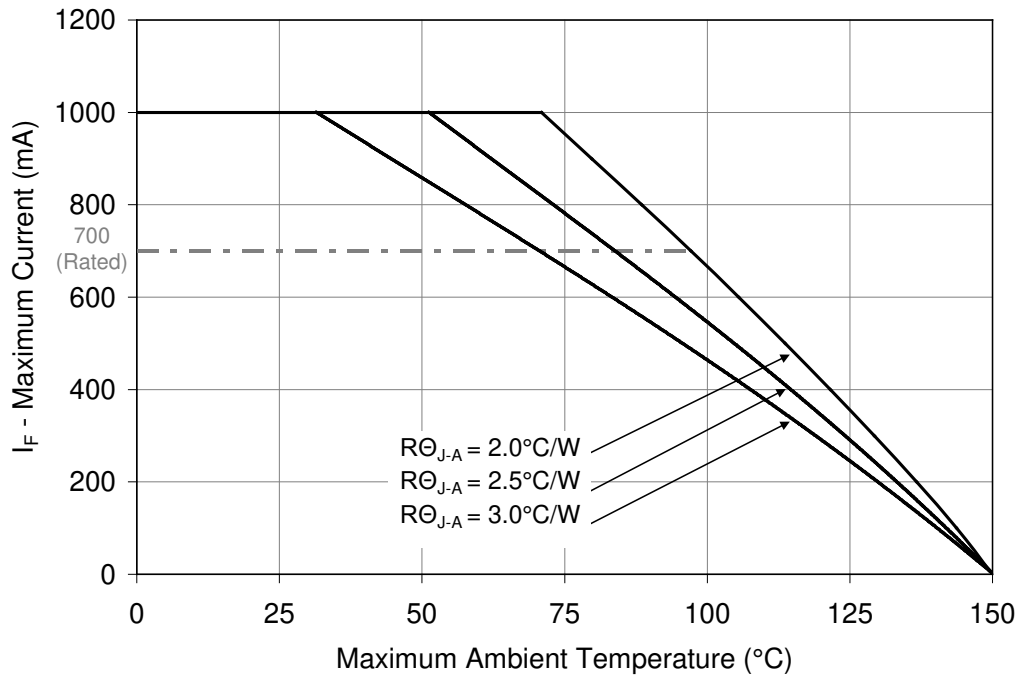

Figure 11: Maximum forward current vs. ambient temperature based on $T_{j(\text{MAX})} = 150^\circ\text{C}$.

Notes for Figure 11:

1. Maximum current assumes that all 12 LED dice are operating concurrently at the same current.
2. $R\theta_{J-C}$ [Junction to Case Thermal Resistance] for the LZC-03MC00 is typically 0.7°C/W .
3. $R\theta_{J-A}$ [Junction to Ambient Thermal Resistance] = $R\theta_{J-C} + R\theta_{C-A}$ [Case to Ambient Thermal Resistance].

Emitter Tape and Reel Specifications (mm)

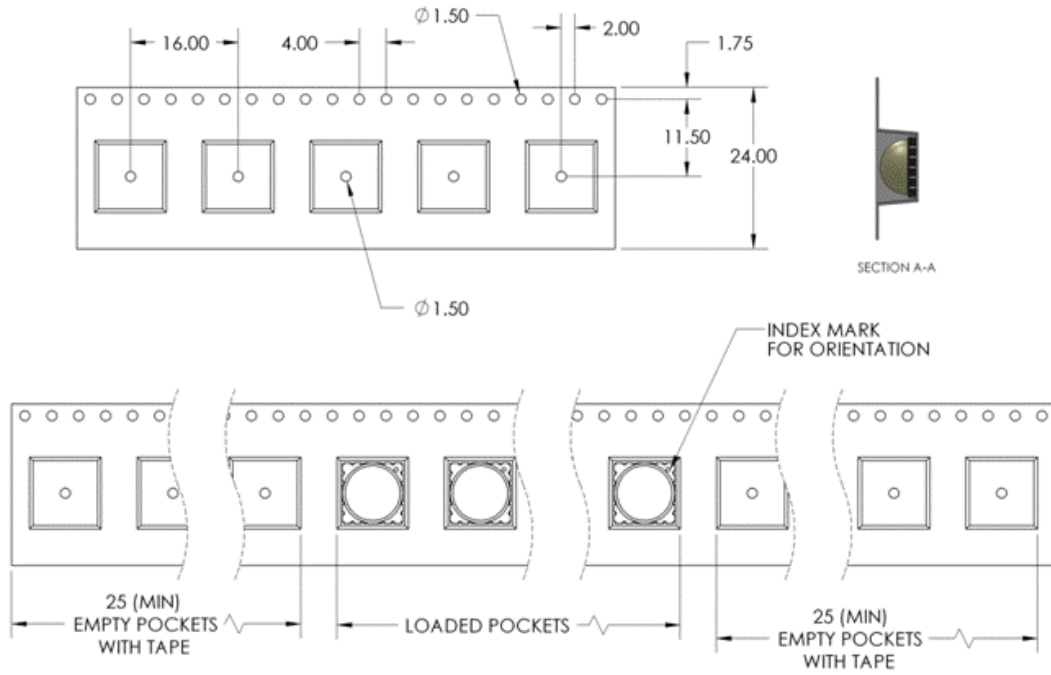

Figure 12: Emitter carrier tape specifications (mm).

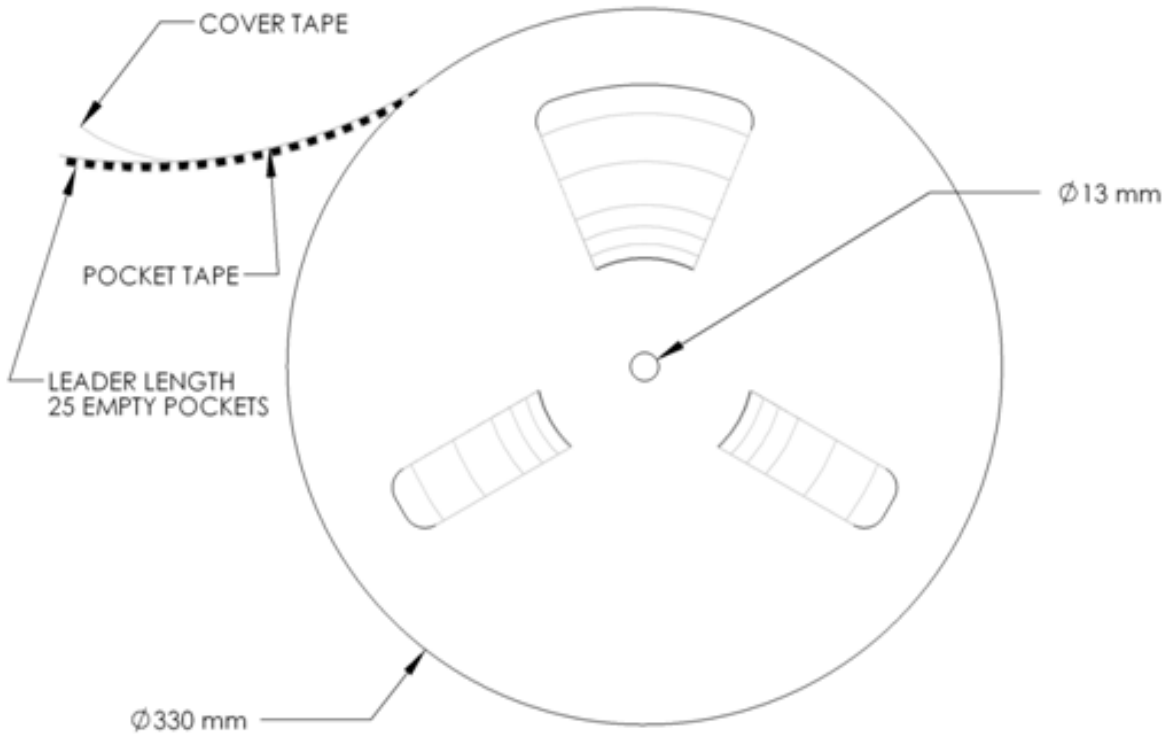

Figure 13: Emitter Reel specifications (mm).

Part-number Nomenclature

The LZ Series base part number designation is defined as follows:

LZ A – B C D E F G – H I J K

A – designates the number of LED die in the package

- 1 for single die emitter package
- 4 for 4-die emitter package
- 9 for 9-die emitter package
- C for 12-die emitter package
- P for 25-die emitter package

B – designates the package level

- 0 for Emitter only

Other letters indicate the addition of a MCPCB. See appendix “MCPCB options” for details

C – designates the radiation pattern

- 0 for Clear domed lens (Lambertian radiation pattern)
- 1 for Flat-top
- 3 for Frosted domed lens

D and E – designates the color

- U6 Ultra Violet (365nm)
- UA Violet (400nm)
- DB Dental Blue (460nm)
- B2 Blue (465nm)
- G1 Green (525nm)
- A1 Amber (590nm)
- R1 Red (623nm)
- R2 Deep Red (660nm)
- R3 Far Red (740nm)
- WW Warm White (2700K-3500K)
- W9 Warm White CRI 90 Minimum (2700K-3500K)
- NW Neutral White (4000K)
- CW Cool White (5500K-6500K)
- W2 Warm & Cool White mixed dies
- MC RGB
- MA RGBA
- MD RGBW (6500K)

F and G – designates the package options if applicable

See “Base part number” on page 2 for details. Default is “00”

H, I, J, K – designates kit options

See “Bin kit options” on page 2 for details. Default is “0000”

Ordering information:

For ordering LED Engin products, please reference the base part number above. The base part number represents our standard full distribution flux and wavelength range. Other standard bin combinations can be found on page 2. For ordering products with custom bin selections, please contact a LED Engin sales representative or authorized distributor.

LZC MCPCB Family

Part number	Type of MCPCB	Diameter (mm)	Emitter + MCPCB Thermal Resistance (°C /W)	Typical V _f (V)	Typical I _f (mA)
LZC-8xxxxx	3-channel	28.3	0.7 + 0.6 = 1.3	9.4 – 16.8	700

▪ Mechanical Mounting of MCPCB

- Mechanical stress on the emitter that could be caused by bending the MCPCB should be avoided. The stress can cause the substrate to crack and as a result might lead to cracks in the dies.
- Therefore special attention needs to be paid to the flatness of the heat sink surface and the torque on the screws. Maximum torque should not exceed 1 Nm (8.9 lbf/in).
- Care must be taken when securing the board to the heatsink to eliminate bending of the MCPCB. This can be done by tightening the three M3 screws (or #4-40) in steps and not all at once. This is analogous to tightening a wheel of an automobile
- It is recommended to always use plastic washers in combination with three screws. Two screws could more easily lead to bending of the board.
- If non taped holes are used with self-tapping screws it is advised to back out the screws slightly after tighten (with controlled torque) and retighten the screws again.

▪ Thermal interface material

- To properly transfer the heat from the LED to the heatsink a thermally conductive material is required when mounting the MCPCB to the heatsink
- There are several materials which can be used as thermal interface material, such as thermal paste, thermal pads, phase change materials and thermal epoxies. Each has pro's and con's depending on the application. For our emitter it is critical to verify that the thermal resistance is sufficient for the selected emitter and its environment.
- To properly transfer the heat from the MCPCB to the heatsink also special attention should be paid to the flatness of the heatsink.

▪ Wire soldering

- For easy soldering of wires to the MCPCB it is advised to preheat the MCPCB on a hot plate to a maximum of 150°. Subsequently apply the solder and additional heat from the solder iron to initiate a good solder reflow. It is recommended to use a solder iron of more than 60W. We advise to use lead free, no-clean solder. For example SN-96.5 AG-3.0 CU 0.5 #58/275 from Kester (pn: 24-7068-7601)

LZC-8xxxxx

3-Channel MCPCB Mechanical Dimensions (mm)

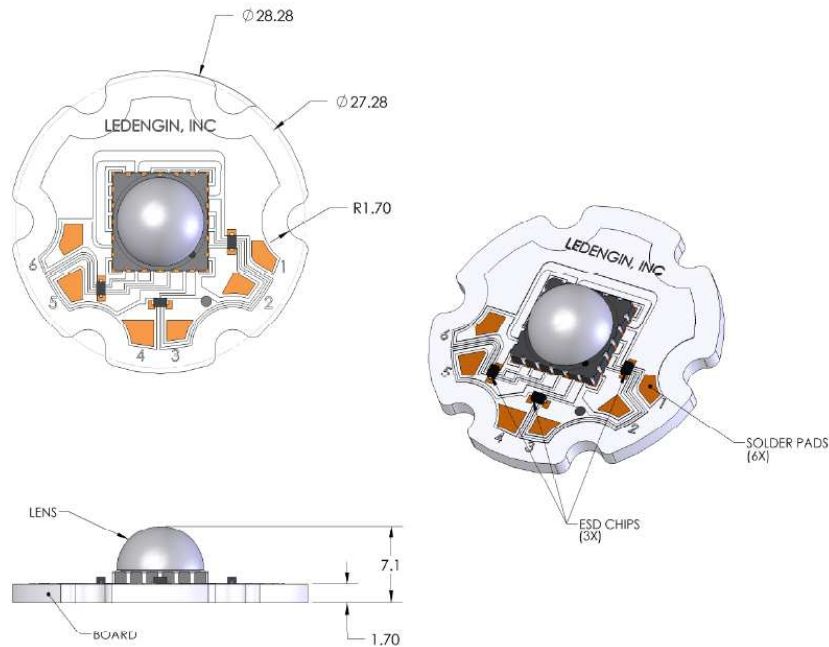

Pin Function with:			
LZC-00MC00			
Pad	Polarity	Function	Ch.
1	Cathode -	Blue	3
2	Anode +		
3	Anode +	Red	1
4	Cathode -		
5	Cathode -	Green	2
6	Anode +		

Note for Figure 1:

- Unless otherwise noted, the tolerance = ± 0.20 mm.
- Slots in MCPCB are for M3 or #4 mounting screws.
- LED Engin recommends using plastic washers to electrically insulate screws from solder pads and electrical traces.
- LED Engin recommends using thermally conductive tape or adhesives when attaching MCPCB to a heat sink.
- The thermal resistance of the MCPCB is: $R_{\theta C-B} 0.6^{\circ}\text{C}/\text{W}$

Components used

MCPCB: HT04503

ESD chips: BZX585-C30

(Bergquist)

(NPX, for 4 LED dies in series)

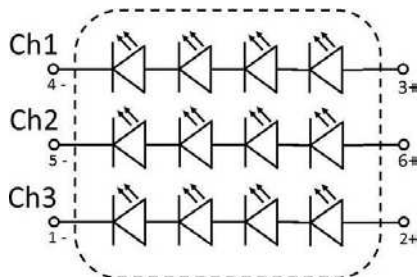

Company Information

LED Engin, Inc., based in California's Silicon Valley, specializes in ultra-bright, ultra compact solid state lighting solutions allowing lighting designers & engineers the freedom to create uncompromised yet energy efficient lighting experiences. The LuxiGen™ Platform — an emitter and lens combination or integrated module solution, delivers superior flexibility in light output, ranging from 3W to 90W, a wide spectrum of available colors, including whites, multi-color and UV, and the ability to deliver upwards of 5,000 high quality lumens to a target. The small size combined with powerful output allows for a previously unobtainable freedom of design wherever high-flux density, directional light is required. LED Engin's packaging technologies lead the industry with products that feature lowest thermal resistance, highest flux density and consummate reliability, enabling compact and efficient solid state lighting solutions.

LED Engin is committed to providing products that conserve natural resources and reduce greenhouse emissions.

LED Engin reserves the right to make changes to improve performance without notice.

Please contact sales@ledengin.com or (408) 922-7200 for more information.