



Chipsmall Limited consists of a professional team with an average of over 10 year of expertise in the distribution of electronic components. Based in Hongkong, we have already established firm and mutual-benefit business relationships with customers from,Europe,America and south Asia,supplying obsolete and hard-to-find components to meet their specific needs.

With the principle of "Quality Parts,Customers Priority,Honest Operation,and Considerate Service",our business mainly focus on the distribution of electronic components. Line cards we deal with include Microchip,ALPS,ROHM,Xilinx,Pulse,ON,Everlight and Freescale. Main products comprise IC,Modules,Potentiometer,IC Socket,Relay,Connector.Our parts cover such applications as commercial,industrial, and automotives areas.

We are looking forward to setting up business relationship with you and hope to provide you with the best service and solution. Let us make a better world for our industry!



Contact us

Tel: +86-755-8981 8866 Fax: +86-755-8427 6832

Email & Skype: info@chipsmall.com Web: www.chipsmall.com

Address: A1208, Overseas Decoration Building, #122 Zhenhua RD., Futian, Shenzhen, China



Features

- Detects single-frequency tones used for error indication and call progress in telephone systems
- Provides detection windows for:
 - 400/425 Hz (Call Progress)
 - 950 Hz (Special and error indication)
 - 1400 Hz (Special and error indication)
 - 1800 Hz (Special and error indication)
- Separate tri-state outputs for each tone window
- Inexpensive 3.58 MHz crystal time base
- Auxiliary 3.58 MHz clock output
- 14-pin DIP package and 16-pin SOIC package
- Single supply 3 to 5 volt (low power CMOS)
- Wide dynamic range (30 dBm)

Applications

- Automatic dialers
- Modems
- Telecom test equipment
- Telephone traffic measurement,
- Service evaluation
- Billing equipment

Pin Diagram

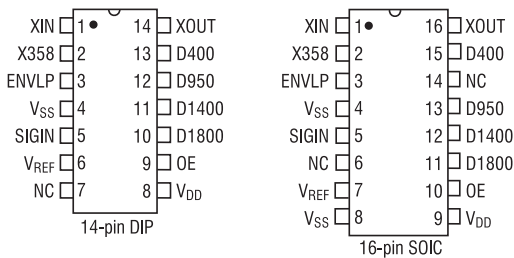

Description

The M-984-02 Special Information Tone Detector is a monolithic integrated circuit designed to provide reliable detection of many common telephone network status signals. In particular, it detects the signals known as Special Information Tones (SITs) or error tones as defined by the CCITT, and single tones often used as dial tone, audible ringing, and other general progress indications. The M-984-02 uses CMOS switched capacitor filters and a crystal time base to achieve the high stability and accuracy specified. Each tone detection window has an associated output pin, which can be placed in a high impedance state for use with time-share microcomputer bus applications.

In comparison with the earlier M-984, the M-984-02 has wider acceptance bands for SIT tones to facilitate reception of tape-loop tones, lower power consumption at 5V operation, 3V operation, superior temperature performance, lower cost, and is available in DIP, SOIC, and SOIC tape and reel versions.

Ordering Information

Part #	Description
M-984-02P	14-pin plastic DIP
M-984-02S	16-pin plastic, SOIC
M-984-02T	16-pin SOIC, Tape and Reel

Block Diagram

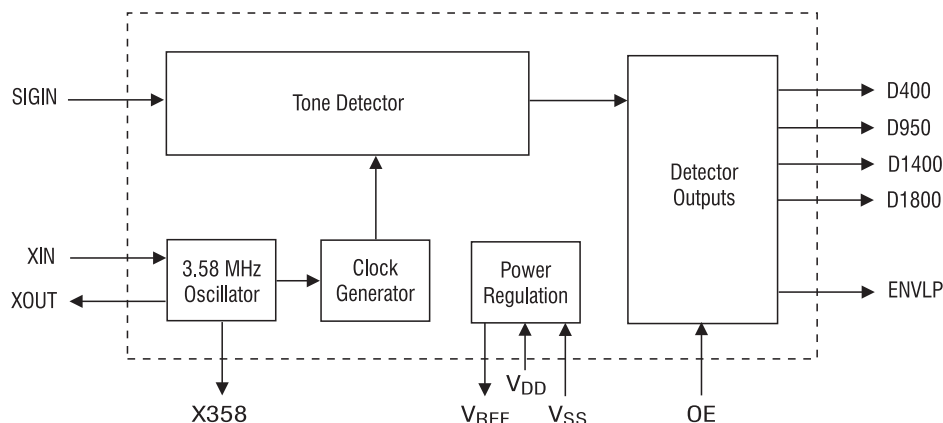

**M-984-02****Absolute Maximum Ratings**

DC Supply Voltage	7V
Input Voltage on SIGIN	$V_{SS} - 6.5V$ to $V_{DD} + 0.3V$
Input Voltage on Any Pin (except SIGIN)	$V_{SS} - 0.3$ to $V_{DD} + 0.3V$
Storage Temperature Range	-40°C to +150°C
Operating Temperature Range	-40°C to +85°C
Lead Soldering Temperature	260°C for 5 seconds

Note:

Exceeding these ratings may permanently damage the device.

Absolute Maximum Ratings are stress ratings. Stresses in excess of these ratings can cause permanent damage to the device. Functional operation of the device at these or any other conditions beyond those indicated in the operational sections of this data sheet is not implied. Exposure of the device to the absolute maximum ratings for an extended period may degrade the device and effect its reliability.

Specifications

Parameter		Conditions	Min	Max	Units	
Operating Conditions	V_{DD}	-	2.7	5.5	V	
	Power supply noise	0.1 - 5 kHz	-	20	mV p-p	
Power	Current drain (I_{DD})	V_{REF} open	-	15	mA	
V_{REF}	V_{REF}	-	48% of V_{DD}	52% of V_{DD}	V	
	Impedance	-	3.25	8.25	k Ω	
Signal Detection	Frequency Range	-	Note 1	Note 1	-	
	Level: $V_{DD} = 5.0V$	-	-30 (24.5 mV)	0 (775 mV)	dBm	
	Level: $V_{DD} = 3.0V$	-	-33 (17.4 mV)	-3 (173.5 mV)	dBm	
	Duration	$f_c = 400$ Hz	-	85	-	ms
		$f_c = 950, 1400, 1800$ Hz	-	50	-	ms
	Bridge Time	-	-	15	ms	
Signal to Noise Ratio	-	-	16	-	dB	
Signal Rejection	Frequency Range	-	Note 1	Note 1	-	
	Level: $V_{DD} = 5.0V$	-	-	-40 (7.8 mV)	dBm	
	Level: $V_{DD} = 3.0V$	-	-	-43 (5.5 mV)	dBm	
	Duration	-	-	50	ms	
Outputs	Except X358	V_{OL}	$I_{SINK} = -1.0$ mA	-	0.5	V
		V_{OH}	$I_{SOURCE} = 1.0$ mA	$V_{DD} - 0.5$	-	V
	Dn pins only	I_{OZ}	$V_O = V_{DD}, V_{SS}$	-	1	μ A
Inputs	EN pin	V_{IL}	-	-	0.5	V
		V_{IH}	$V_{DD} = 5V$	$V_{DD} - 2.0$	-	V
	Pull-up and Pull-down currents	MODE = V_{SS}	$V_{DD} = 5V$	12.5	50	μ A
			$V_{DD} = 2.7V$	4	20	μ A
		/XRANGE + V_{SS}	-	2	6	μ A
			MODE2 = V_{DD}	$V_{DD} = 5V$	12.5	100
			$V_{DD} = 2.7V$	12.5	25	μ A
		PD = V_{DD}	-	4	10	μ A
	SIGIN pin	Voltage range	-	-6.5	V_{DD}	V
		Input impedance	$f = 500$ Hz	80	-	k Ω
Input Spectrum		-	-	28	kHz	
Clock	External clock connected to XIN pin	V_{IL}	XOUT open	-	0.2	V
		V_{IH}	XOUT open	$V_{DD} - 0.2$	-	V
	XIN, XOUT with crystal ocs. active	Duty cycle	XOUT open	40	60	%
		Capacitance	-	-	10	pF
	X358 pin	Internal res.	-	20	-	M Ω
		V_{OL}	$C_L = 20$ pF, $I_{SINK} = -1.0$ mA	-	0.5	V
			V_{OH}	$C_L = 20$ pF, $I_{SOURCE} = 1.0$ mA	$V_{DD} - 0.5$	-
Duty cycle	$C_L = 20$ pF	40	60	%		
Tri-state Operation	t_{FN} (High Z to Low Z)	$C_L = 50$ pF	-	250	ns	
	t_{DE} (Low Z to High Z)	RL = 100 K Ω	-	250	ns	

Unless otherwise noted, specifications hold over $V_{DD} - V_{SS} = 2.8V$ to 5.5V power supply, and $T_{OL} -40^\circ C$ to +85°C.**Notes:**

1. See the Detector Frequency Windows table on page 4 for detection/ rejection frequencies.

Pin Functions

PIN	FUNCTION
XIN	Crystal Connection — 3.58 MHz crystal across these pins will produce the timebase needed for proper operation of the M-984-02. An external clock signal may be fed to XIN providing the clock signal has a duty cycle of $50 \pm 10\%$ and comes within 0.2 volts of the supply rails. XOUT remains unconnected when an external clock is used.
XOUT	
X358	A buffered output pin. A 3.58 MHz clock signal is available for use in other circuits as a timebase. Leave open when unused.
ENVLP	The ENVLP pin is a common detection indicator for the four detect pins. Simply put, the ENVLP is a logical "OR" of the active detect circuits for each of the four windows, though there is a delay provided to permit ENVLP to latch the first active detect pin. ENVLP is not tri-state controlled.
V _{SS}	The power supply pins, V _{DD} being the most positive. Commonly, V _{DD} is at 3-5 volts, while V _{SS} is at ground.
V _{DD}	
SIGIN	Analog signal input. (Internally capacitively coupled.)
V _{REF}	V _{REF} is a bias voltage generated in the chip for use in external analog circuits, such as active filters and AC-coupled buffers. Leave open when unused.
OE	The tri-state control pin. OE places the DET pins in the active mode when at logic "1". When at logic "0," OE causes the DET outputs to appear as high impedance. Should be tied to logic "1" when the M-984-02 is not used in a time-shared bus application.
D1800	The detect outputs associated with each window. Tri-state control is available through use of the OE pin. Timing is shown in the Timing Diagram on page 4.
D1400	
D950	
D400	



M-984-02

Typical Application

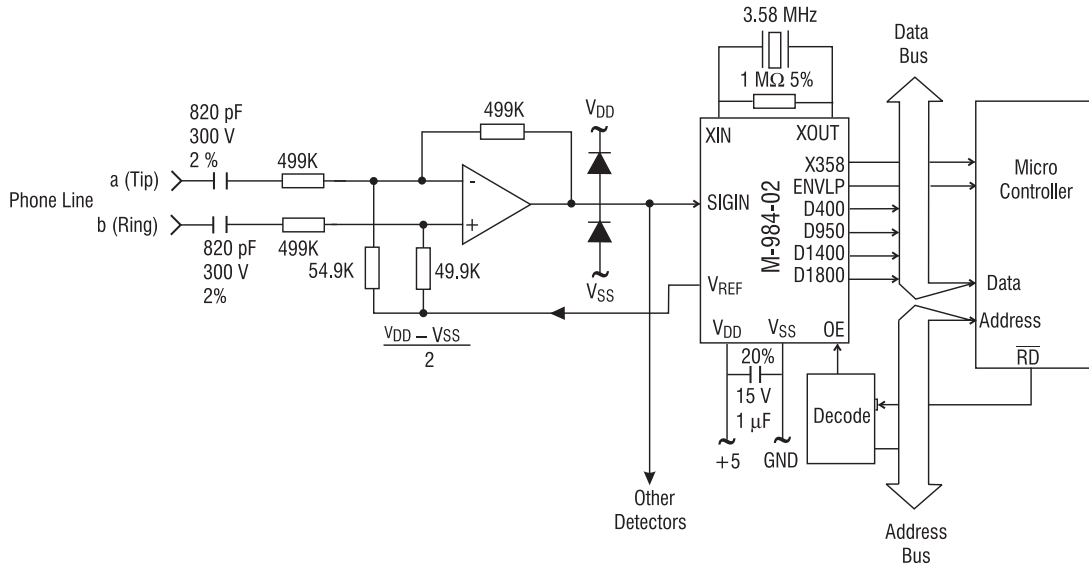

Detector Frequency Windows

Detector	Low Reject	Low Accept	High Accept	High Reject
D400	363	392	459	493
D950	835	885	1016	1070
D1400	1275	1328	1472	1527
D1800	1656	1722	1854	1924

Timing Diagram

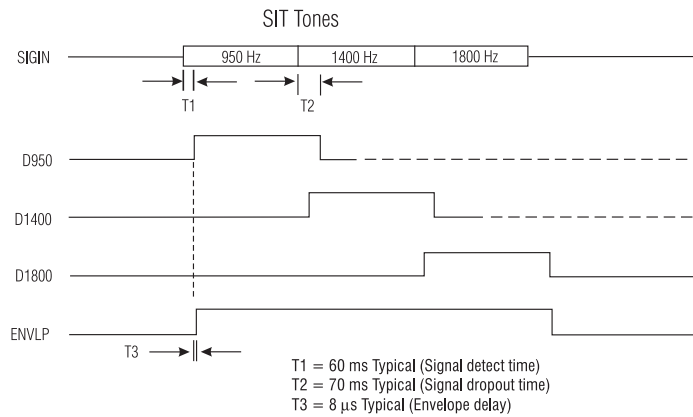

Tri-State Timing

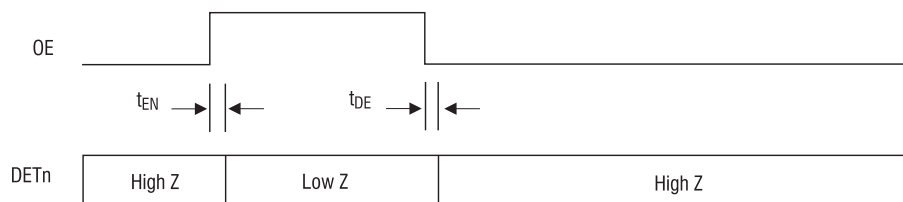

Mechanical Dimensions

14-Pin DIP

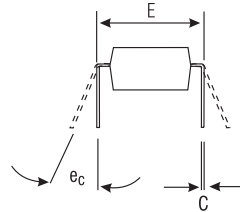
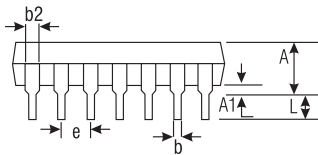
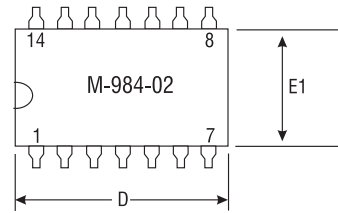

	Tolerances			
	Inches		Metric (mm)	
	Min	Max	Min	Max
A	-	.210	-	5.33
A1	.015	-	.38	-
b	.014	.022	.36	.56
b2	.045	.070	1.1	1.8
C	.008	.014	.20	.36
D	.735	.775	18.7	19.7
E	.300	.325	7.6	8.3
E1	.240	.280	6.1	7.1
e	.100 BSC		2.54 BSC	
ec	0°	15°	0°	15°
L	.115	.150	2.9	4.1

16-Pin SOIC

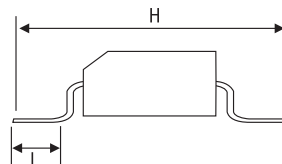
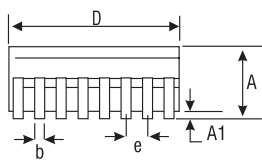
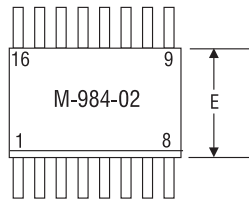

	Tolerances			
	Inches		Metric (mm)	
	Min	Max	Min	Max
A	.093	.104	2.35	2.65
A1	.004	.012	.10	.30
b	.013	.020	.33	.51
D	.398	.413	10.10	10.50
E	.291	.299	7.4	7.6
e	.050 BSC		1.27 BSC	
H	.394	.419	10.00	10.65
L	.016	.050	.40	1.27

Drawing not to scale.
Does not reflect actual part marking.

Dimensions
mm
(inches)



CLARE LOCATIONS

Clare Headquarters
78 Cherry Hill Drive
Beverly, MA 01915
Tel: 1-978-524-6700
Fax: 1-978-524-4900
Toll Free: 1-800-27-CLARE

Clare Switch Division
4315 N. Earth City Expressway
Earth City, MO 63045
Tel: 1-314-770-1832
Fax: 1-314-770-1812

Clare Micronix Division
145 Columbia
Aliso Viejo, CA 92656-1490
Tel: 1-949-831-4622
Fax: 1-949-831-4628

SALES OFFICES

AMERICAS

Americas Headquarters

Clare
78 Cherry Hill Drive
Beverly, MA 01915
Tel: 1-978-524-6700
Fax: 1-978-524-4900
Toll Free: 1-800-27-CLARE

Eastern Region

Clare
603 Apache Court
Mahwah, NJ 07430
Tel: 1-201-236-0101
Fax: 1-201-236-8685
Toll Free: 1-800-27-CLARE

Central Region

Clare Canada Ltd.
3425 Harvester Road, Suite 202
Burlington, Ontario L7N 3N1
Tel: 1-905-333-9066
Fax: 1-905-333-1824

Western Region

Clare
1852 West 11th Street, #348
Tracy, CA 95376
Tel: 1-209-832-4367
Fax: 1-209-832-4732
Toll Free: 1-800-27-CLARE

Canada

Clare Canada Ltd.
3425 Harvester Road, Suite 202
Burlington, Ontario L7N 3N1
Tel: 1-905-333-9066
Fax: 1-905-333-1824

EUROPE

European Headquarters

CP Clare nv
Bampsiaan 17
B-3500 Hasselt (Belgium)
Tel: 32-11-300868
Fax: 32-11-300890

France

Clare France Sales
Lead Rep
99 route de Versailles
91160 Champlan
France
Tel: 33 1 69 79 93 50
Fax: 33 1 69 79 93 59

Germany

Clare Germany Sales
ActiveComp Electronic GmbH
Mitterstrasse 12
85077 Manching
Germany
Tel: 49 8459 3214 10
Fax: 49 8459 3214 29

Italy

C.L.A.R.E.s.a.s.
Via C. Colombo 10/A
I-20066 Melzo (Milano)
Tel: 39-02-95737160
Fax: 39-02-95738829

Sweden

Clare Sales
Comptronic AB
Box 167
S-16329 Spånga
Tel: 46-862-10370
Fax: 46-862-10371

United Kingdom

Clare UK Sales
Marco Polo House
Cook Way
Bindon Road
Taunton
UK-Somerset TA2 6BG
Tel: 44-1-823 352541
Fax: 44-1-823 352797

ASIA/PACIFIC

Asian Headquarters

Clare
Room N1016, Chia-Hsin, Bldg II,
10F, No. 96, Sec. 2
Chung Shan North Road
Taipei, Taiwan R.O.C.
Tel: 886-2-2523-6368
Fax: 886-2-2523-6369

<http://www.clare.com>

Clare, Inc. makes no representations or warranties with respect to the accuracy or completeness of the contents of this publication and reserves the right to make changes to specifications and product descriptions at any time without notice. Neither circuit patent licenses nor indemnity are expressed or implied. Except as set forth in Clare's Standard Terms and Conditions of Sale, Clare, Inc. assumes no liability whatsoever, and disclaims any express or implied warranty, relating to its products including, but not limited to, the implied warranty of merchantability, fitness for a particular purpose, or infringement of any intellectual property right.

The products described in this document are not designed, intended, authorized or warranted for use as components in systems intended for surgical implant into the body, or in other applications intended to support or sustain life, or where malfunction of Clare's product may result in direct physical harm, injury, or death to a person or severe property or environmental damage. Clare, Inc. reserves the right to discontinue or make changes to its products at any time without notice.

Specification: DS-M-984-02-R3
©Copyright 2001, Clare, Inc.
All rights reserved. Printed in USA.
7/17/01