



Chipsmall Limited consists of a professional team with an average of over 10 year of expertise in the distribution of electronic components. Based in Hongkong, we have already established firm and mutual-benefit business relationships with customers from,Europe,America and south Asia,supplying obsolete and hard-to-find components to meet their specific needs.

With the principle of “Quality Parts,Customers Priority,Honest Operation,and Considerate Service”,our business mainly focus on the distribution of electronic components. Line cards we deal with include Microchip,ALPS,ROHM,Xilinx,Pulse,ON,Everlight and Freescale. Main products comprise IC,Modules,Potentiometer,IC Socket,Relay,Connector.Our parts cover such applications as commercial,industrial, and automotives areas.

We are looking forward to setting up business relationship with you and hope to provide you with the best service and solution. Let us make a better world for our industry!



Contact us

Tel: +86-755-8981 8866 Fax: +86-755-8427 6832

Email & Skype: info@chipsmall.com Web: www.chipsmall.com

Address: A1208, Overseas Decoration Building, #122 Zhenhua RD., Futian, Shenzhen, China



MC2045-2Y

Postamplifier/Quantizer for Applications to 200 Mbps

The MC2045-2Y is an integrated, high gain limiting amplifier intended for fibre optic communication to 200 Mbps. Normally placed following the photodetector & transimpedance amplifier, the post-amplifier provides the necessary gain to give PECL compatible logic outputs.

The MC2045-2Y also includes a programmable signal-level detector, allowing the user to set thresholds at which the logic outputs are enabled. The signal detect function has typically 2 dB (optical) of hysteresis which prevents chatter at low input levels.

A JAM function, which turns off the output when no signal is present, is provided by externally connecting the \overline{ST} output to the JAM input.

Applications

- SDH/SONET 155 Mbps Transceivers
- Fast Ethernet Receivers
- FDDI 125 Mbps Receivers
- ESCON Receivers
- FTTx and Media Converters

Features

- Operates with a 3.3 V or 5 V supply
- 1.6 mV typical input sensitivity
- Typical Supply Current 12.5 mA at $V_{CC} = 3.3$ V
- Wide range programmable input-signal level detect
- Complimentary PECL data & signal detect logic outputs
- Output disable function (JAM) when no input signal detected
- Available in TSSOP20, SOIC16, QSOP16 and BCC++16L package as well as die form
- Available in RoHS compliant packages

Functional Block Diagram

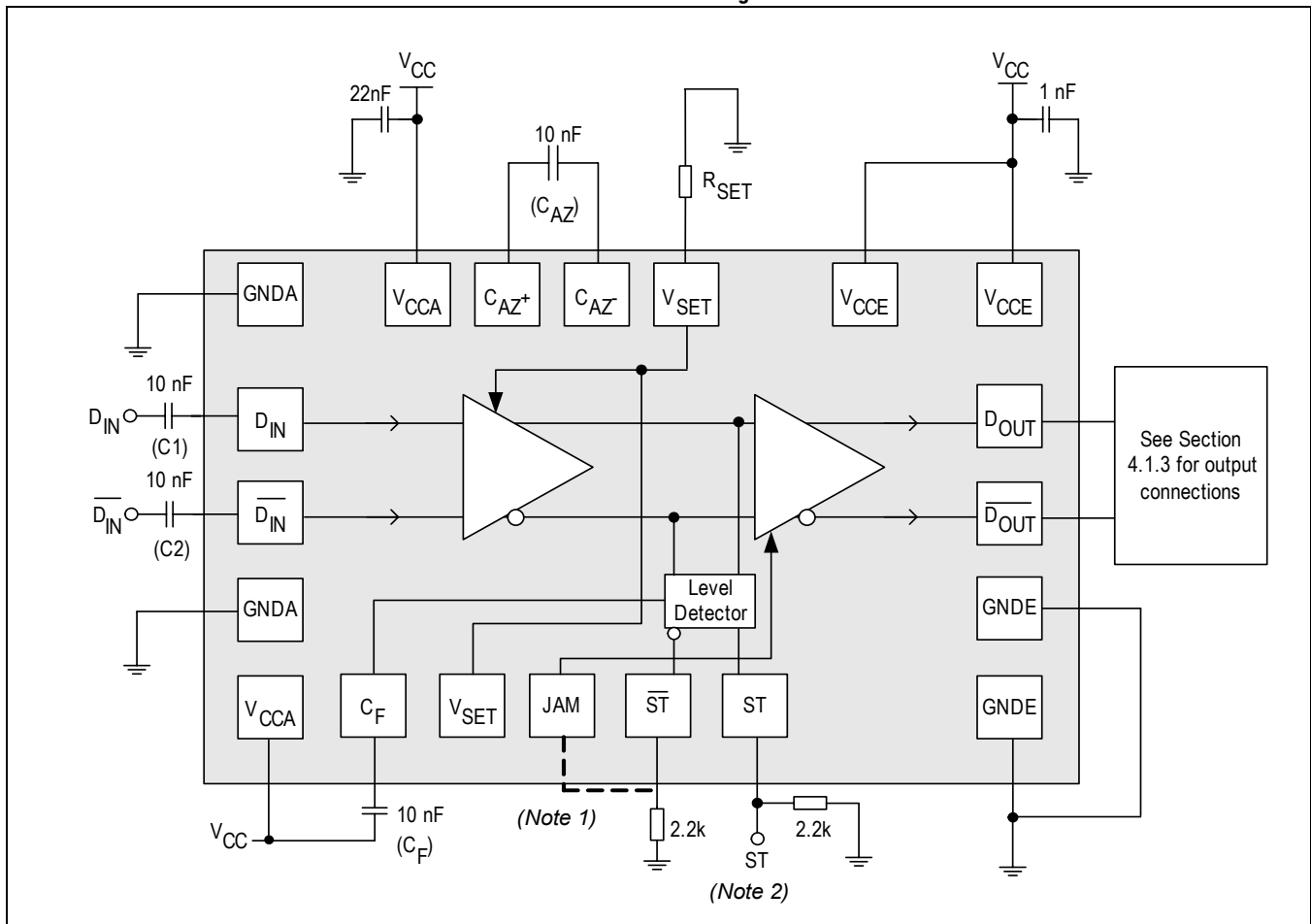

Ordering Information ⁽¹⁾

Part Number	Package	Operating Temperature
M02045-2Y04-T	SOIC16	-40 °C to 85 °C
M02045-2Y03-T	QSOP16	-40 °C to 85 °C
M02045-2Y01-T	TSSOP20	-40 °C to 85 °C
M02045-2Y06-	BCC++16L	-40 °C to 85 °C
M02045G-2Y04-T ⁽²⁾	SOIC16	-40 °C to 85 °C
M02045G-2Y03-T ⁽²⁾	QSOP16	-40 °C to 85 °C
M02045G-2Y01-T ⁽²⁾	TSSOP20	-40 °C to 85 °C
M02045G-2Y06- ⁽²⁾	BCC++16L	-40 °C to 85 °C
M02045-2YDIEWP	Waffle pack	-40 °C to 85 °C
M02045-2YWAFER	Expanded wafer on a grip ring	-40 °C to 85 °C
M02045-2QEVM	QSOP evaluation board	-
M02045-P6EVM	QSOP Eval board includes the MC2006 TIA	-
M02045-P7EVM	QSOP Eval board includes the MC2007 TIA	-

Note:

1. Because the current Mindspeed part number standard uses an M0 prefix, it is used for ordering the MC2045 but the part is still marked as an MC2045 device.
2. The letter "G" designator after the part number indicates that the device is RoHS-compliant. Refer to www.mindspeed.com for additional information.

Revision History

Revision	Level	Date	ASIC Revision	Description
H	Final	September 2005	-2Y	Include RoHS-compliant info, update ordering information and convert to new template.
G	Final	April 2004	-2Y	Public release.

Typical Eye Diagram

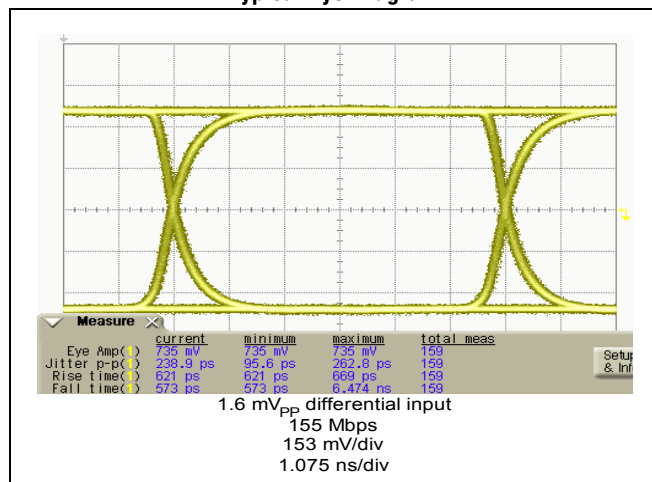

Pin Configuration (QSOP)

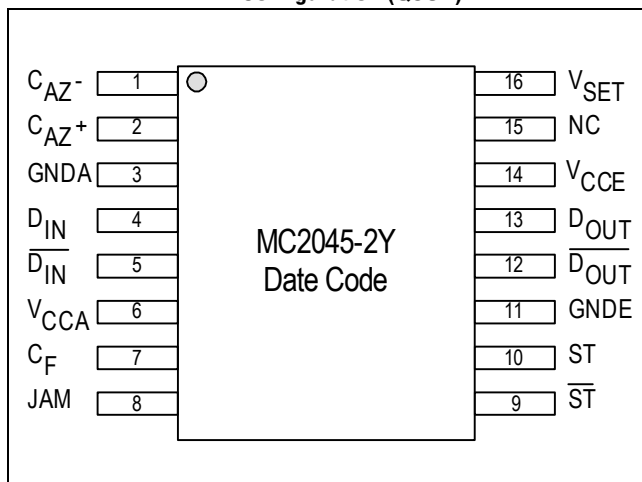



1.0 Product Specification

1.1 Absolute Maximum Ratings

Table 1-1. Absolute Maximum Ratings

Symbol	Parameter	Rating	Units
V_{CC}	Power supply (V_{CC-GND})	6	V
T_A	Operating ambient	-40 to +85	°C
T_{STG}	Storage temperature	-65 to +150	°C

1.2 Recommended Operating Conditions

Table 1-2. Recommended Operating Conditions

Symbol	Parameter	Rating	Units
V_{CC}	Power supply (V_{CC-GND})	3.0 to 5.5	V
T_A	Operating ambient	-40 to +85	°C

1.3 DC Characteristics

$V_{CC} = +3.3V \pm 10\%$ or $+5.0V \pm 10\%$, $T_A = -40^\circ\text{C}$ to $+85^\circ\text{C}$, unless otherwise noted.

Typical Specifications are for $V_{CC} = 3.3V$, $T_A = 25^\circ\text{C}$, unless otherwise noted.

Table 1-3. DC Characteristics

Symbol	Parameter	Min.	Typ.	Max.	Units
I_{CC}	Supply current (outputs un-loaded) ⁽¹⁾	–	12.5	20	mA
V_{OS}	Effective input offset voltage	–	1	–	mV
V_{TH}	Input level detect programmability	2	–	20	mVpp
HYS	Level detect hysteresis (optical)	1.8	2.0	3.0	dB
I_{INJ}	JAM input current HIGH	–	380	–	μA
I_{CC}	Supply current (outputs un-loaded) ⁽²⁾	–	–	20	mA
V_{OH}	PECL ⁽¹⁾ output HIGH	$V_{CC} - 1.025$	–	$V_{CC} - 0.880$	V
V_{OL}	PECL ⁽¹⁾ output LOW	$V_{CC} - 1.810$	–	$V_{CC} - 1.620$	V
V_{JAM}	Jam Activation Voltage	–	$V_{CC} - 1.2$	–	V

Notes:

Dice are designed to operate over an ambient temperature range of -40°C to $+85^\circ\text{C}$ (T_A), but are tested and guaranteed only at $T_A = 25^\circ\text{C}$.

1. Load is $50\ \Omega$ to $V_{CC} - 2\ \text{V}$. Typical is 14.5 mA at $V_{CC} = 5.0\ \text{V}$.

2. Typical is 0.5 mV at $V_{CC} = 5.0\ \text{V}$.

1.4 AC Characteristics

$V_{CC} = +3.3V \pm 10\%$ or $+5.0V \pm 10\%$, $T_A = -40^\circ C$ to $+85^\circ C$, unless otherwise noted.

Typical Specifications are for $V_{CC} = 3.3V$, $T_A = 25^\circ C$, unless otherwise noted.

Table 1-4. AC Characteristics

Symbol	Parameter	Min.	Typ.	Max.	Units
V_{IN_MIN}	Differential Input sensitivity	–	1.6	2	mVpp
V_{IN_MAX}	Differential Input Overload	800	–	–	mVpp
BW	Bandwidth (where gain = 60dB)	100	250	–	MHz
R_{IN}	Input resistance	–	10	–	k Ω
C_{IN}	Input capacitance	–	–	2	pF
t_{PWD}	Pulse width distortion	–	–	0.3	ns
t_R, t_F	Data output rise/fall times (20-80%)	–	1.0	2.0	ns
R_F	Signal level detect filter resistance	10	25	41	k Ω
T_{LD}	Signal level detect time constant ⁽¹⁾ Assert level Deassert level	0.5	5 50	100 100	μs
V_N	Input RMS noise in 100 MHz	–	–	85	μV

Notes:

Dice are designed to operate over an ambient temperature range of $-40^\circ C$ to $+85^\circ C$ (T_A), but are tested and guaranteed only at $T_A = 25^\circ C$.

1. Using SFF/SFP typical applications circuit, [Figure 4-2](#).

Figure 1-1. Data Input Requirements

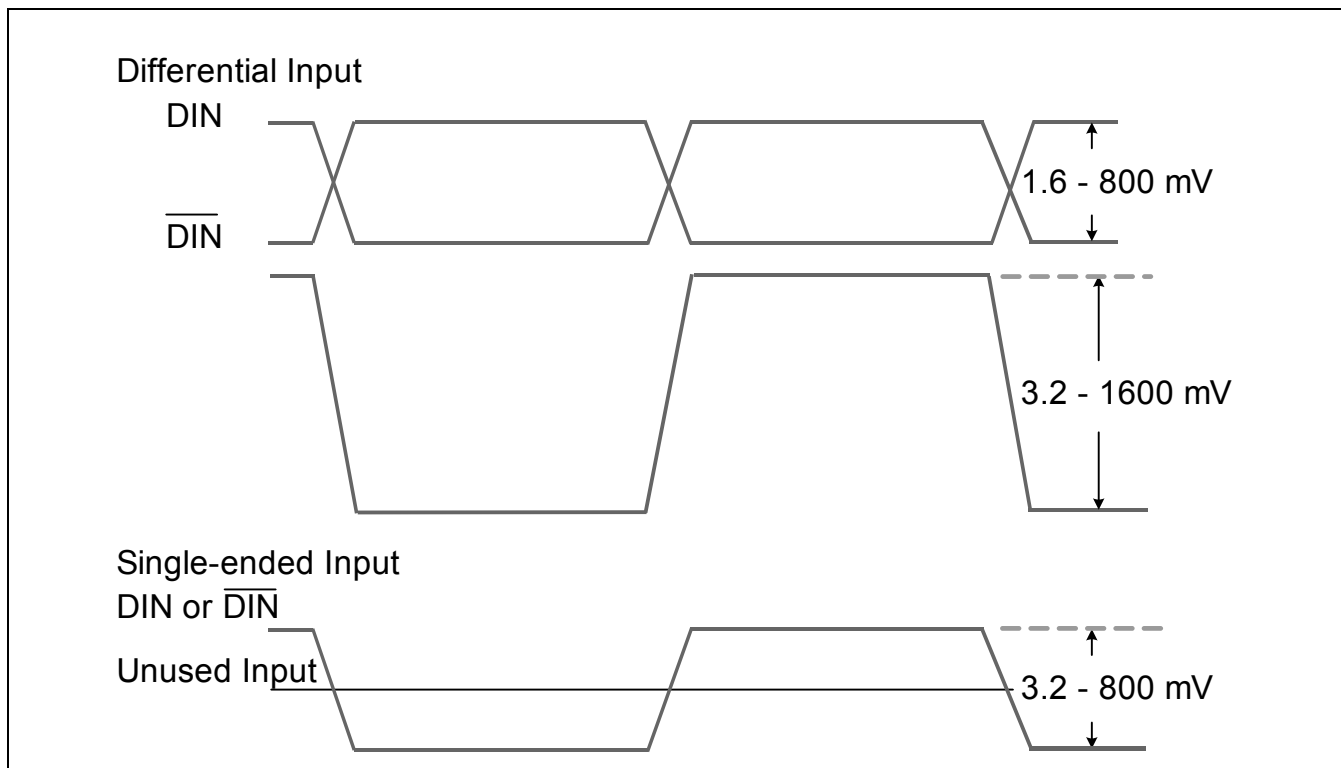

1.5 Typical Eye Diagram

Figure 1-2. MC2045 155 Mbps

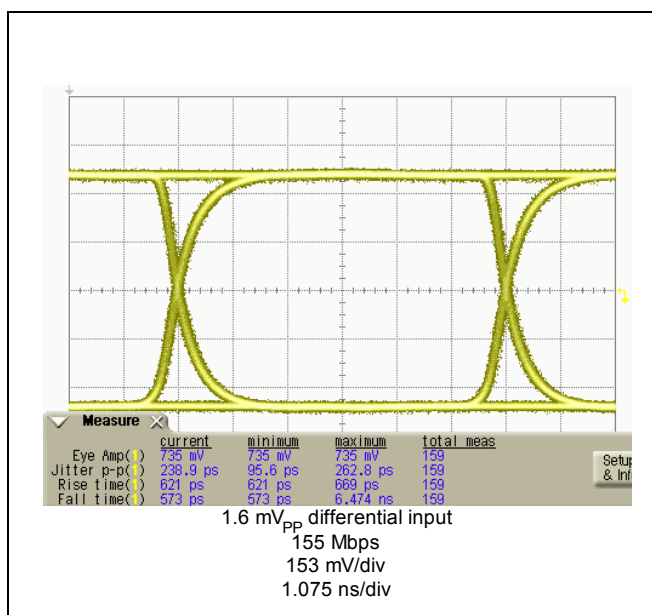



2.0 Pin Definitions

Table 2-1. Pin Description

Pin Name	QSOP16 SOIC16 Pin No.	TSSOP20 Pin No.	BCC++16L Pin No	Function
C _{AZ-}	1	1	15	Auto-zero capacitor pin. Connect C _{AZ} between this pin and C _{AZ+}
C _{AZ+}	2	2	16	Auto-zero capacitor pin. Connect C _{AZ} between this pin and C _{AZ-}
GNDA	3	4	-	Analog section ground pin. Connect to most negative supply. Must be at the same potential as GNDE pin
D _{IN}	4	5	2	Differential data input
D _{IN}	5	6	3	Inverse differential data input
V _{CCA}	6	7	1, 4	Analog section power pin. Connect to most positive supply. Must be at the same potential as V _{CCE} pin
C _F	7	8	5	Level-detect filter capacitor pin. Connect a capacitor between this pin and V _{CCA}
JAM	8	11	6	PECL compatible input controlling output buffers (D _{OUT} and D _{OUT} pins). On chip 10 kΩ pull down defaults to low. Can be driven from CMOS
\overline{ST}	9	12	7	Logical inverse of ST pin. Maybe connected to JAM pin to enable automatic squelch function to disable the data outputs
ST	10	13	8	Input signal level status. This PECL output is low when the input signal is below the threshold set by the users
GNDE	11	14, 15	10	Digital section ground pin, Connect to the most negative supply. Must be the same potential as GNDA pin
D _{OUT}	12	16	11	Differential data output. Logical inverse of D _{OUT} pin. JAM high forces D _{OUT} high
D _{OUT}	13	17	12	Differential data output. PECL compatible differential data output. JAM high forces D _{OUT} low
V _{CCE}	14	18, 19	13	Digital output section power pin. Connect the most positive supply. Must be at same potential as V _{CCA} pin
NC	15	3, 9, 10	9	Not connected
V _{SET}	16	20	14	Input threshold-level setting circuit. Connect to GND via a resistor

NOTE:
Pin 17 (center pin) on the BCC++16 package should be connected to GndA.

Figure 2-1. Package Pinouts

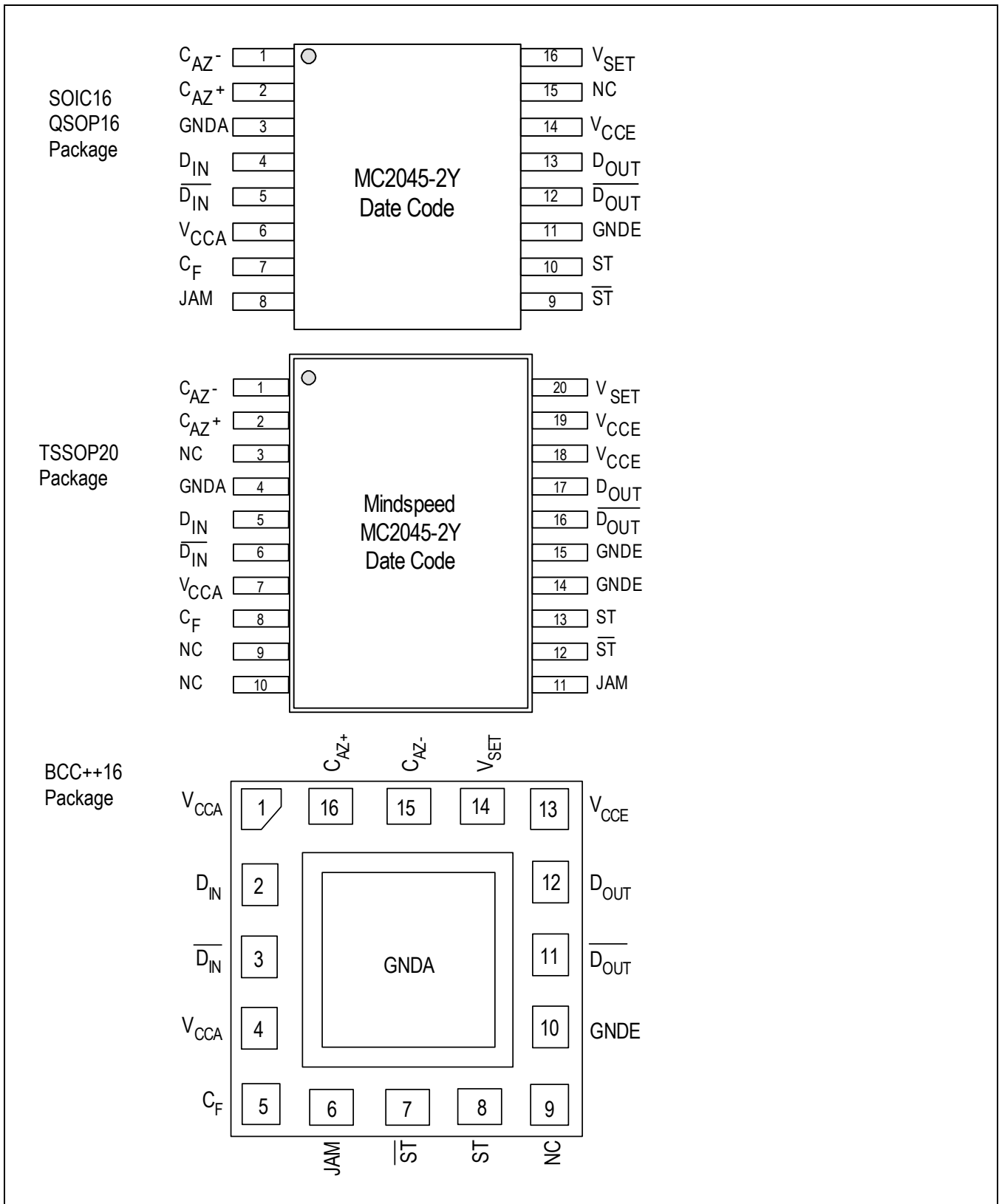



3.0 Functional Description

3.1 Overview

The MC2045-2Y is an integrated, high gain limiting amplifier intended for fibre optic communication to 200 Mbps. Normally placed following the photodetector & transimpedance amplifier, the post-amplifier provides the necessary gain to give PECL compatible logic outputs.

The MC2045-2Y also includes a programmable signal-level detector, allowing the user to set thresholds at which the logic outputs are enabled. The signal detect function has typically 2 dB (optical) of hysteresis which prevents chatter at low input levels.

A JAM function, which turns off the output when no signal is present, is provided by externally connecting the \overline{ST} output to the JAM input.

Figure 3-1. Block Diagram

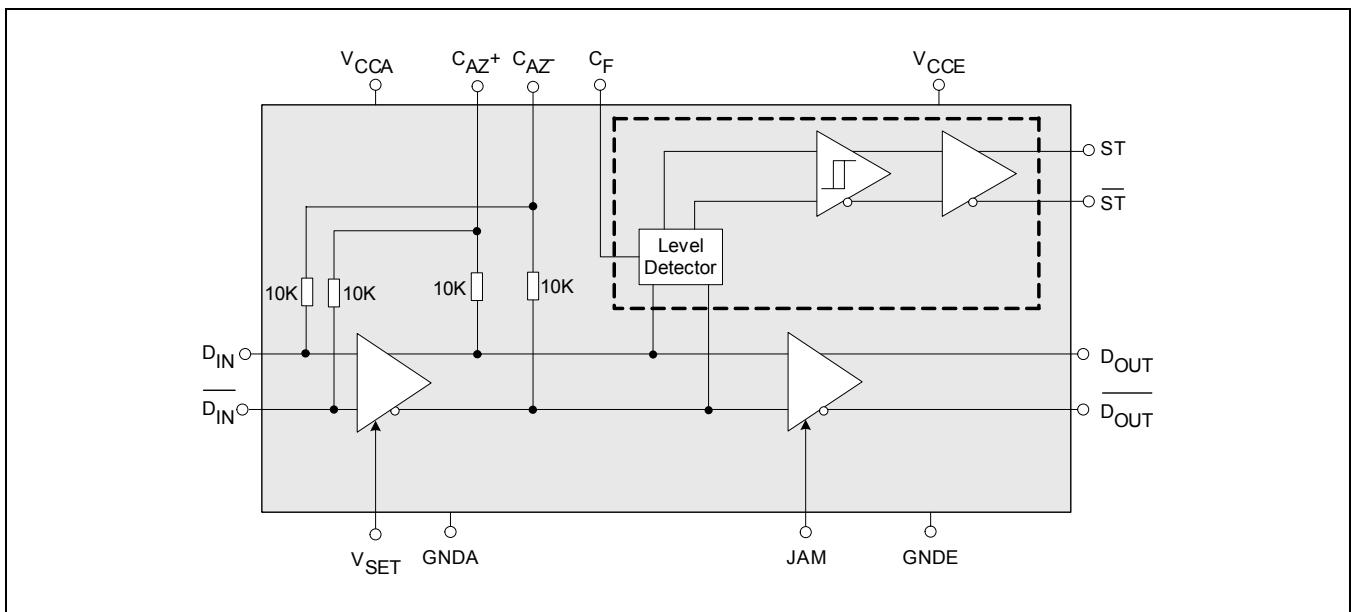

3.2 Features

- Operates with a 3.3 V or 5 V supply
- 1.6 mV typical input sensitivity
- Typical Supply Current 12.5 mA at $V_{CC} = 3.3$ V
- Wide range programmable input-signal level detect
- Complimentary PECL data & signal detect logic outputs
- Output disable function (JAM) when no input signal detected
- Available in TSSOP20, SOIC16, QSOP16 and BCC++16L package as well as die form

3.3 General Description

3.3.1 Data Inputs

The data input pins are internally DC-biased at approximately $V_{CC} - 1V$ so the MC2045-2Y input signals need to be AC-coupled using external capacitors. These capacitors must be large enough to pass the lowest frequencies of interest (consecutive '1's or '0's) considering the input resistance. For example, at 155 Mbps SONET, there can be up to a maximum of 72 consecutive '1' s, which is 465 ns (corresponding to a frequency of 1.08 MHz).

To minimize the data dependent jitter, the AC-coupled input low frequency cutoff needs to be lower than the above by a factor of 10 (<100 kHz). However, it is better to set it an additional factor of 5 - 10 lower (~ 10 to 20 kHz) due to the interaction of the time constants for the input stage and the DC restore circuitry. For example, setting C1 and C2 (Figure 4-1 and Figure 4-2) to 10 nF gives a typical -3 dB point of approximately 1.6 kHz and 4.7 nF gives 3.4 kHz.

3.3.2 DC Offset Compensation

Internal feedback is included to remove the effects of both TIA output DC offset and internal MC2045-2Y DC offset and acts as a DC auto zero circuit. An external capacitor (C_{AZ}) acting with the internal circuit feedback resistors (typically 20 k Ω) ensures that the feedback is effective only at frequencies below the lowest frequency of interest. C_{AZ} is normally set to 300 pF - 10 nF depending upon the application (see Figure 4-1 and Figure 4-2).

3.3.3 Signal Level Detector (\overline{ST} and \overline{ST})

The gain of the first stage is determined by R_{SET} . This amplification sets the level of input signal at which the status threshold operates. The data from the first stage is rectified and low-pass filtered before being compared with a reference voltage. The low-pass filter is formed by C_F (Figure 4-1 and Figure 4-2) and R_F (on chip resistor).

With C_F equal to 10 nF the time constant is nominally 2 μ s, avoiding false triggering due to variation in the edge density of the input data.

3.3.4 JAM Function

The JAM function sets the data output to a fixed state when a valid signal level is not present at the inputs (as determined by the user with R_{SET}). This is implemented by externally connecting the \overline{ST} output to the JAM input.

JAM is normally used to allow data to propagate only when the signal is above the users' Bit-Error-Rate (BER) requirement. It stops the data outputs toggling due to noise when a valid signal level is not present at the inputs.



4.0 Applications Information

4.1 Applications

- SDH/SONET 155 Mbps Transceivers
- Fast Ethernet Receivers
- FDDI 125 Mbps Receivers
- ESCON Receivers
- FTTx and Media Converters

Figure 4-1. Typical 9 Pin Applications Circuit

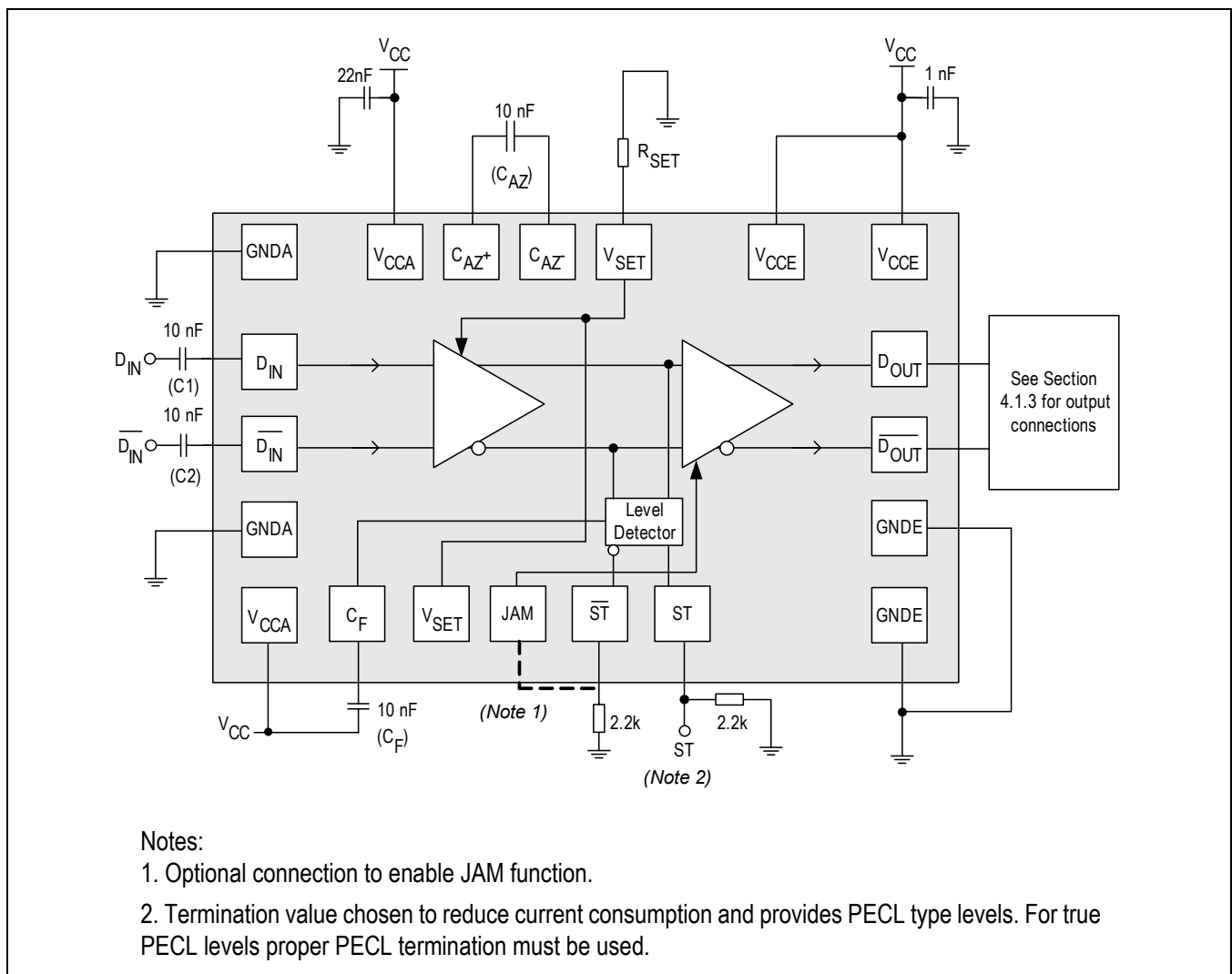
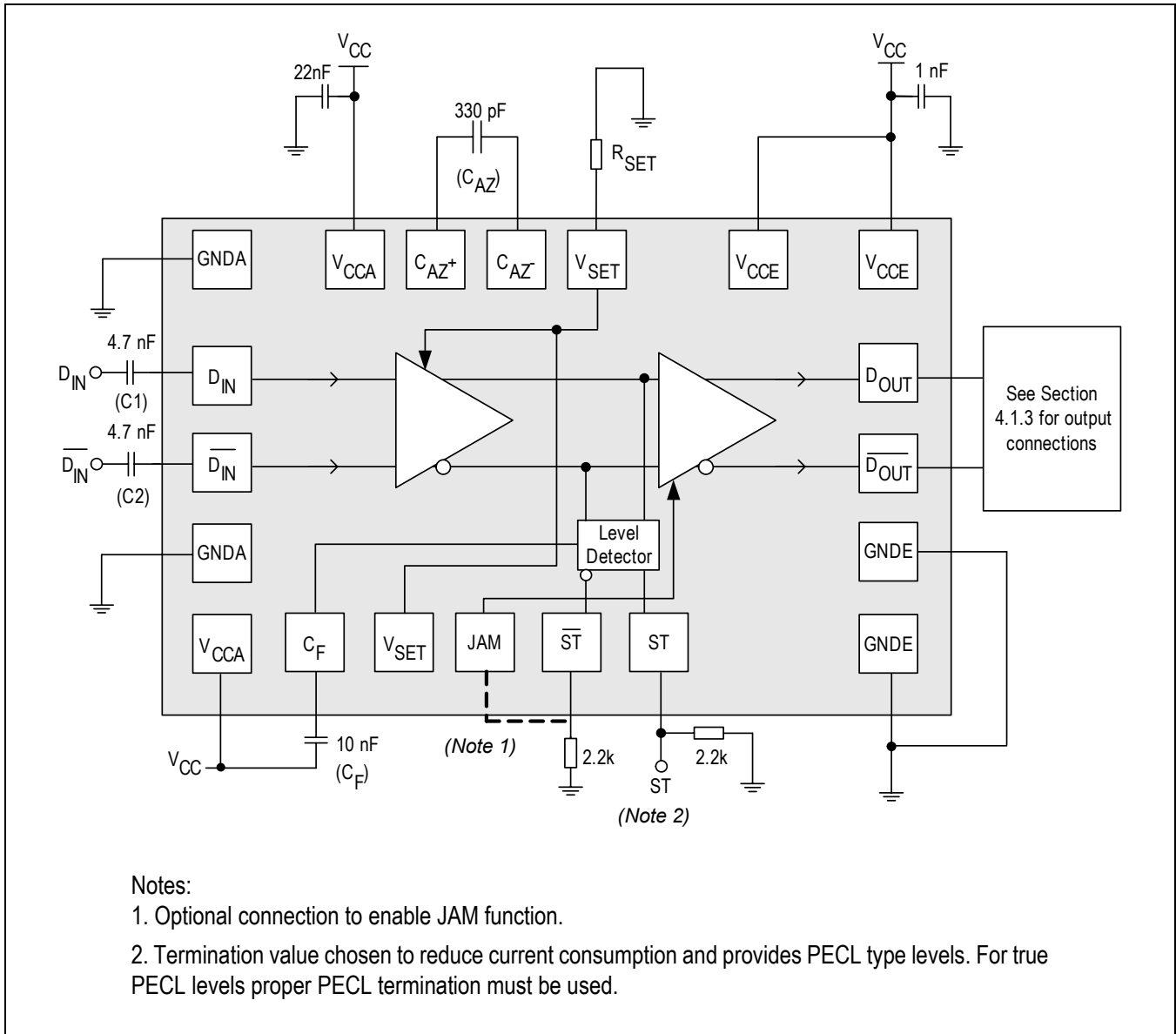

Figure 4-2. Typical SFF/SFP Applications Circuit



4.1.1 Setting the Signal Detect Level

R_{SET} is chosen using the graph in Figure 4-3 or Figure 4-4 to determine the input signal level at which ST goes high (Assert). The value is dependant on supply voltage and should be chosen for 3.3 V or 5 V operation. If 3.3 V and 5 V operation are to be supported interchangeably set RSET based on the 3.3 V graphs.

The comparator following the level detector has the equivalent of 2 dB (typ.) of optical hysteresis, and this determines the deassert level (ST goes LOW).

If the level detect function is not required connect V_{SET} to GndA (maximum gain and minimum signal detect level).

Figure 4-3. Typical Loss of Signal Characteristic at $V_{CC} = 3.3V$

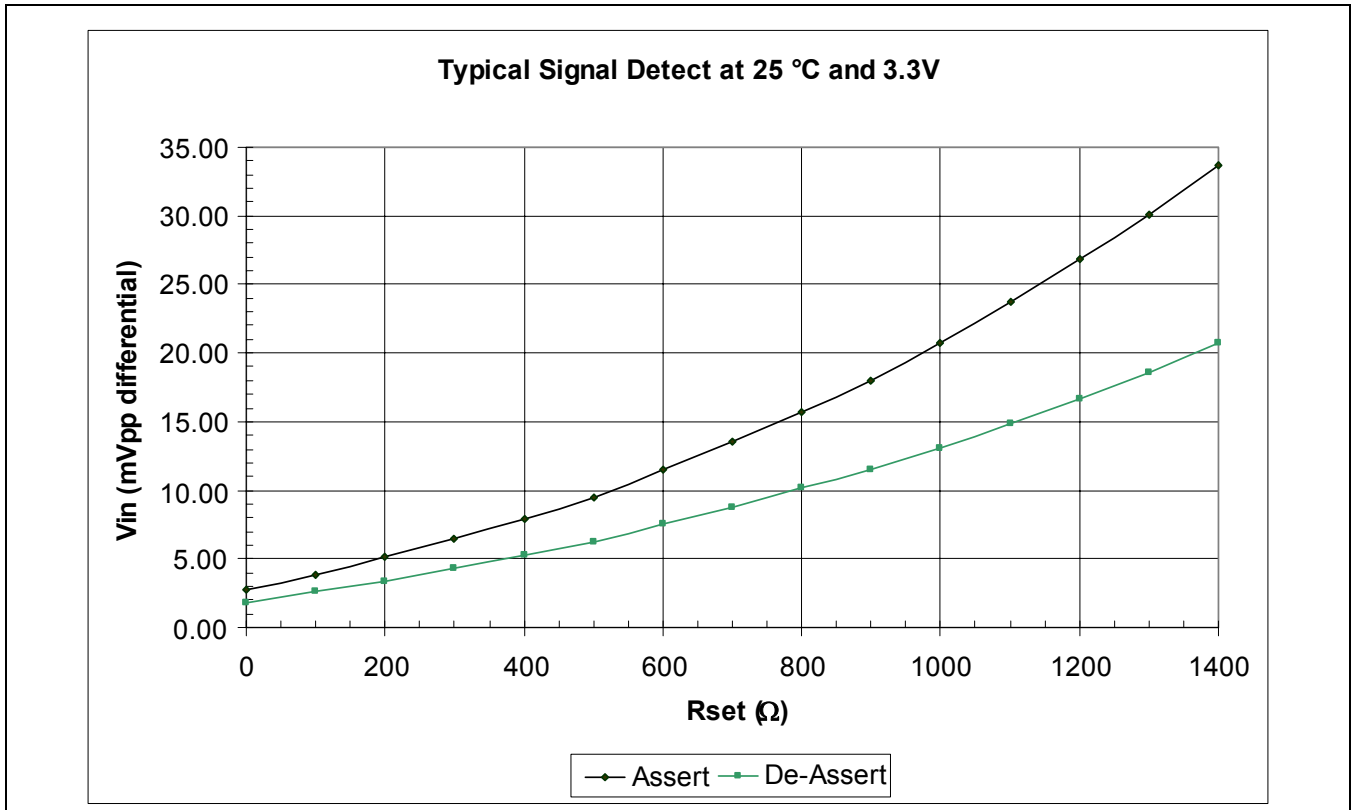
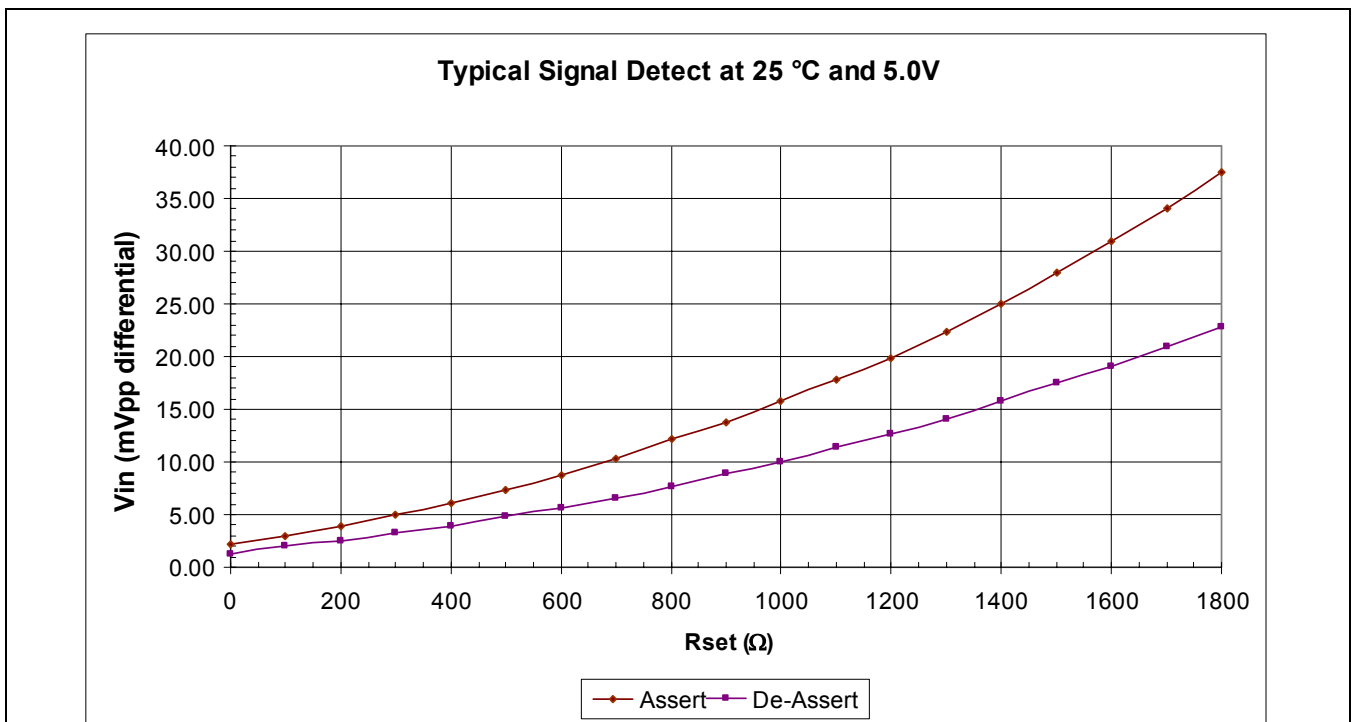

Figure 4-4. Typical Loss of Signal Characteristic at $V_{CC} = 5.0V$



4.1.2 Signal Detect Hysteresis

Figure 4-5 shows the operation of the signal detect function as the signal level varies. The top line indicates the assert level, the bottom the deassert level. The difference between the two levels is the hysteresis. When the signal level goes above the assert level the ST output switches high (\overline{ST} switches low). When the signal level falls below the deassert level, ST output switches low (\overline{ST} switches high).

Figure 4-5. Signal Detect Hysteresis

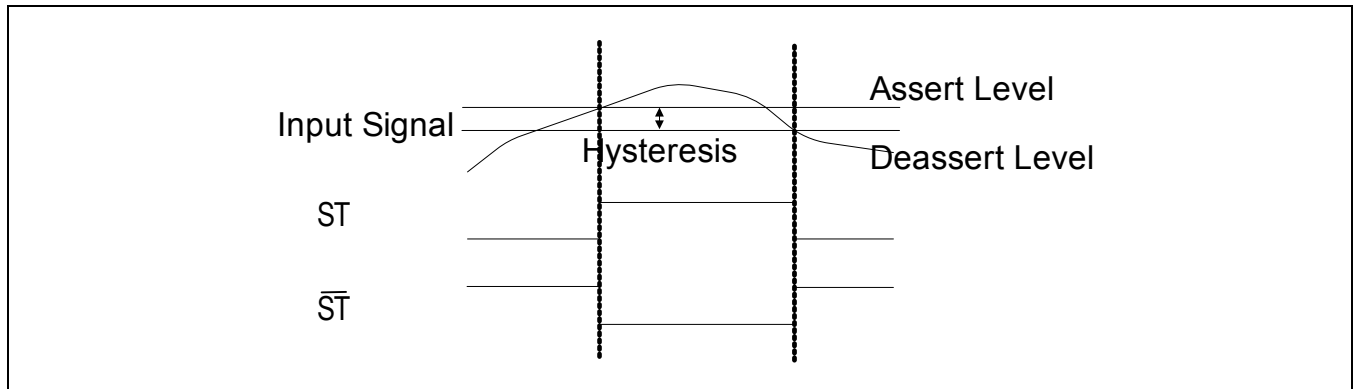

4.1.3 PECL Termination

The outputs of the MC2045-2Y are PECL compatible and any standard AC or DC-coupling termination technique can be used. Figure 4-6 and Figure 4-7 illustrate typical AC and DC terminations.

AC-coupling is used in applications where the average DC content of the data is zero e.g. SONET. The advantage of this approach is lower power consumption, no susceptibility to DC drift and compatibility with non-PECL interfaces. Pull-down resistors ($R_{pull-down}$) provide a DC path for the emitter follower outputs to ground, keeping the ECL output transistors in their active region. Figure 4-6 shows the circuit configuration and Table 4-1 lists the resistor values. If using non-50Ω transmission lines, the shunt termination resistance Z_T should equal twice the impedance of the transmission line (Z_O).

DC-coupling can be used when driving PECL interfaces and has the advantage of a reduced component count. A Thevenin termination is used at the receive end to give a 50 Ω load and the correct DC bias. Figure 4-7 shows the circuit configuration and Table 4-1 the resistor values.

Alternatively, if available, terminating to $V_{CC} - 2V$ as shown in Figure 4-8 has the advantage that the resistance value is the same for 3.3 V and 5 V operation and it also has performance advantages at high data rates.

Table 4-1. Termination Resistor Values

Supply	Output Impedance	$R_{Pull-down}$	Z_T	R_{TA}/R_{TB}	R_T/R_B
5 V	50 Ω	270 Ω	100 Ω	2k7 Ω/7k8 Ω	82 Ω/130 Ω
3.3 V	50 Ω	150 Ω	100 Ω	2k7 Ω/4k3 Ω	130 Ω/82 Ω

Figure 4-6. AC-coupled PECL Termination

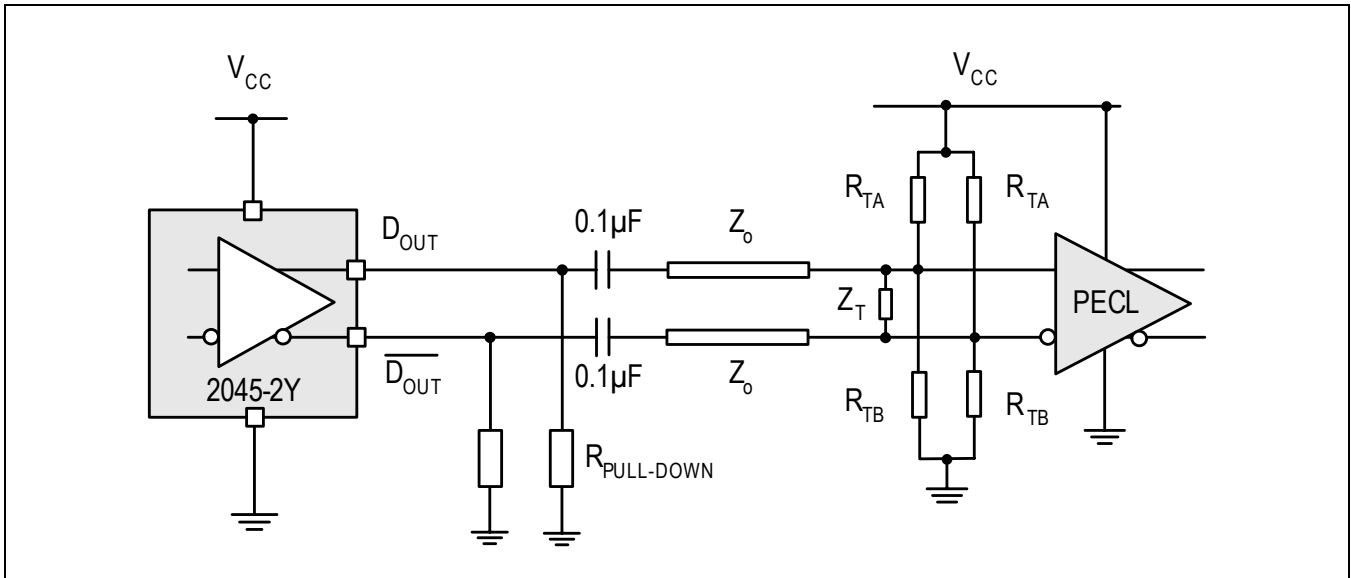

Figure 4-7. DC-coupled PECL Termination

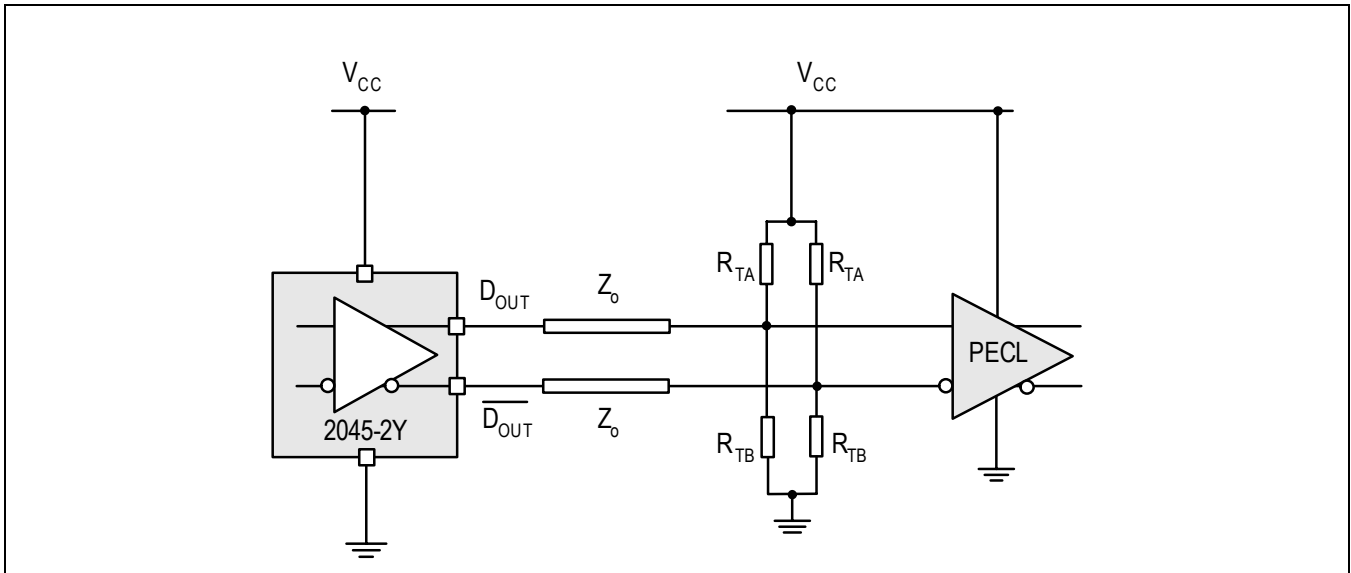
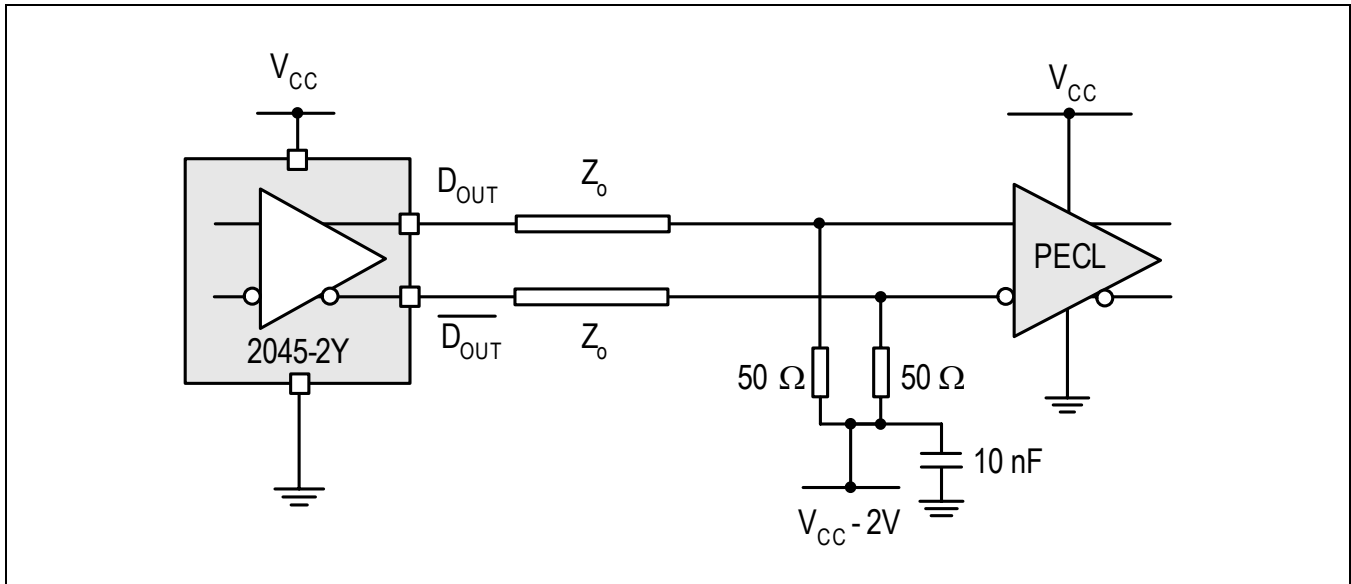

Figure 4-8. True PECL Termination



4.1.4 JAM Function

The JAM function, sets the data output to a fixed state when no valid signal is present at the input. This is implemented by externally connecting the \overline{ST} output to the JAM input.

This is normally used to allow data to propagate only when the signal is above the users' Bit-Error-Rate (BER) requirement. It therefore stops the data outputs toggling due to noise when no signal is present.

4.1.5 Power supply decoupling & optimizing sensitivity

In most applications the MC2045-2Y will give adequate performance without ferrite beads. In applications where maximum sensitivity is required V_{CCA} and $GNDA$ may be connected to their respective power rails via a ferrite suppressor, such as a Murata BLM31A601SPT.

Capacitors should be chosen with low effective series resistance, low dissipation factor and high Q. NPO or COG temperature characteristics are preferred because they provide more reliable performance over a wide range of environmental conditions.

Small surface mount packages are recommended since they exhibit less parasitic inductance which can lower the overall effectiveness of the bypass capacitor at high frequencies. Filter capacitors should be placed close to power and ground pins to minimize noise coupling.

4.1.6 Differences between the die and packaged parts

The die has two V_{SET} pads. Connect one or the other, but not both.

There are two sets of V_{CCA} and $GNDA$ on the left of the die. Although two pairs are provided only one pair need be connected. On the TSSOP package, pairs of $V_{CC}E$ and $GNDE$ pins are connected.



5.0 Package and Die Specification

5.1 Package Specification

5.1.1 BCC++16L 16 Lead Package

Figure 5-1. BCC++16L Package Outline

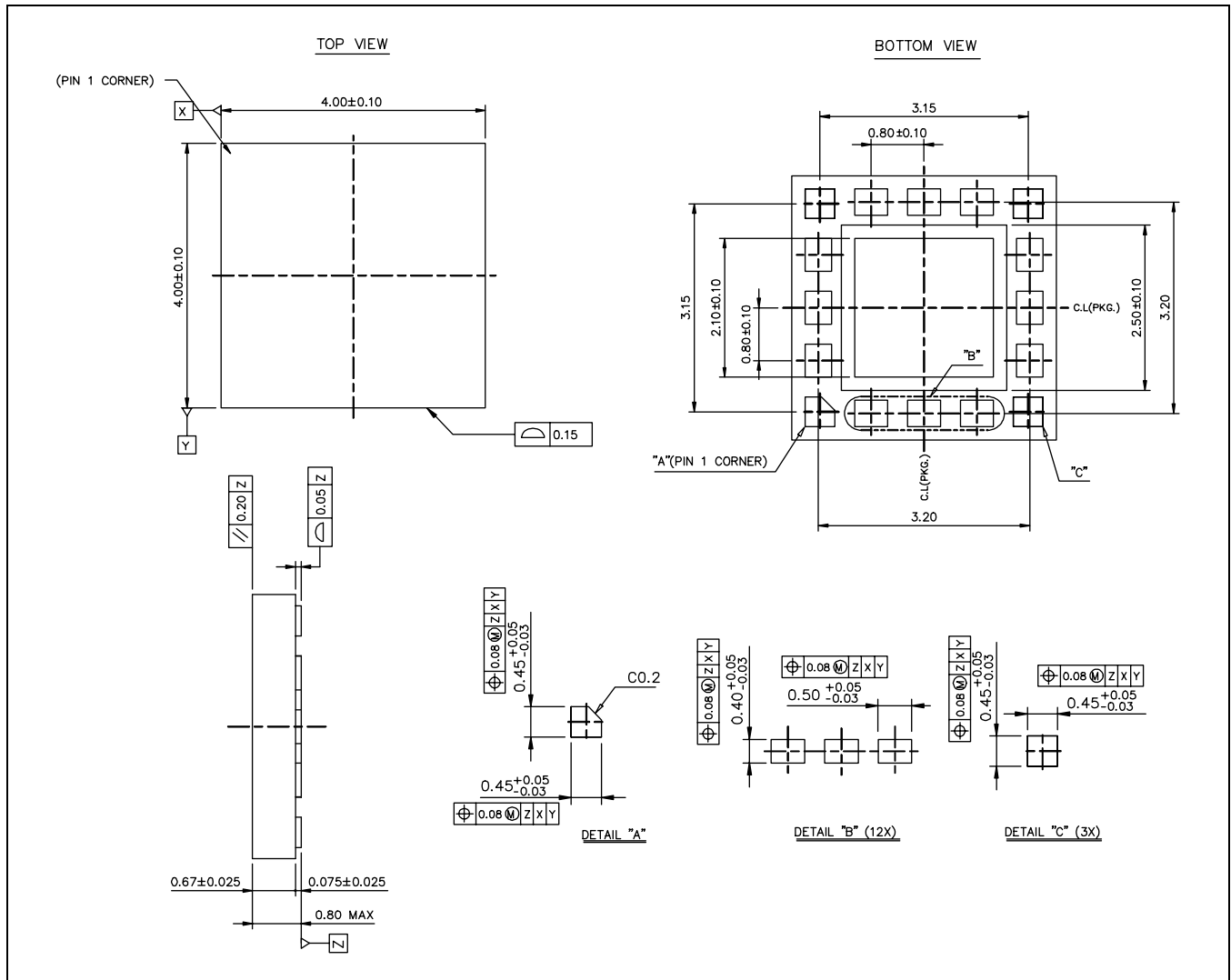

5.1.2 SOIC 16 Pin Package

Figure 5-2. SOIC16 Package Information

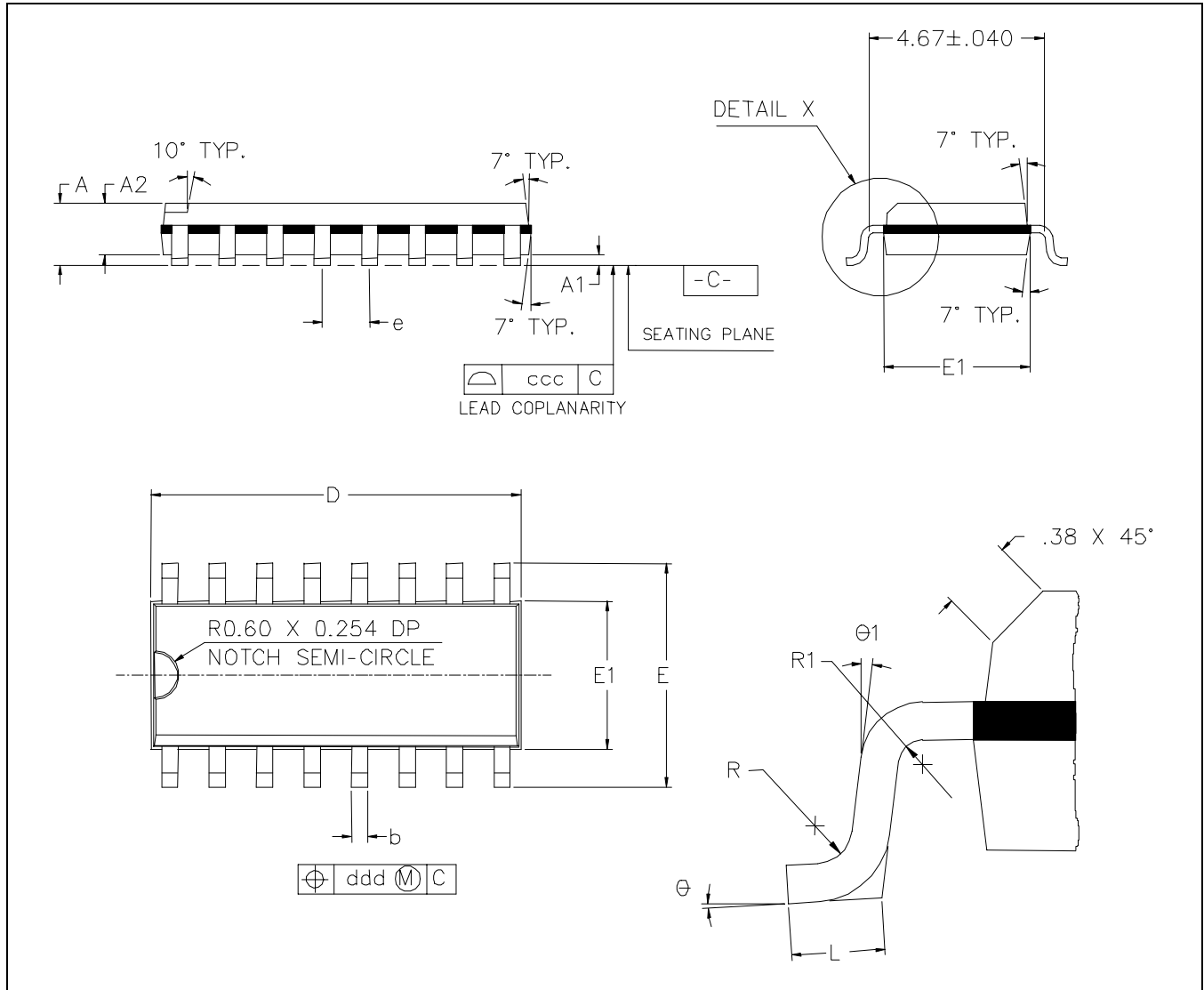

Table 5-1. SOIC16 Dimensions

Symbol	Min.	Nom.	Max.
A	1.55	1.63	1.73
A1	0.127	0.15	0.25
A2	1.40	1.47	1.55
B	0.35	0.41	0.49
C	0.19	0.20	0.25
D	9.80	9.93	9.98
E	3.81	3.94	3.99

Symbol	Min.	Nom.	Max.
e	1.27 BSC		
H	5.84	5.99	6.20
h	0.25	0.33	0.41
L	0.41	0.64	0.89
N	16		
a	0°	5°	8°
X	2.16	2.36	2.54

5.1.3 QSOP 16 Pin Package

Figure 5-3. QSOP16 Package Information

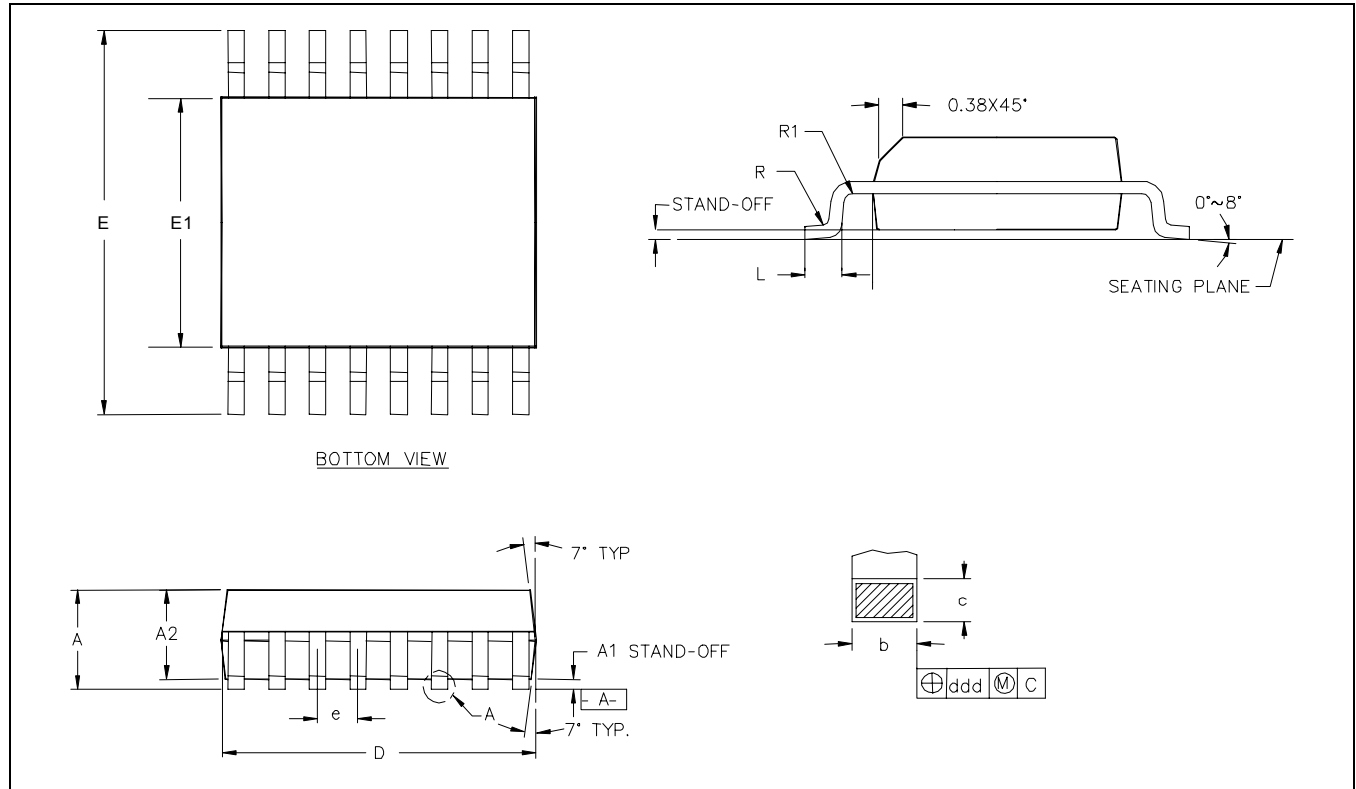

Table 5-2. QSOP16 Dimensions

Symbol	Tols/N	QSOP16
A	MAX.	1.60
A1	± 0.05	0.1
A2	± 0.05	1.40
D	± 0.05	4.95
E	± 0.10	6.00
E1	± 0.05	3.90
L	± 0.15	0.60
ccc	MAX.	0.080
ddd	MAX.	0.10
e	BASIC	0.635
b	± 0.025	0.224
c	± 0.02	0.22
R	± 0.05	0.25
R1	Min.	0.20

5.1.4 TSSOP 20 Pin Package

Figure 5-4. TSSOP20 Package Information

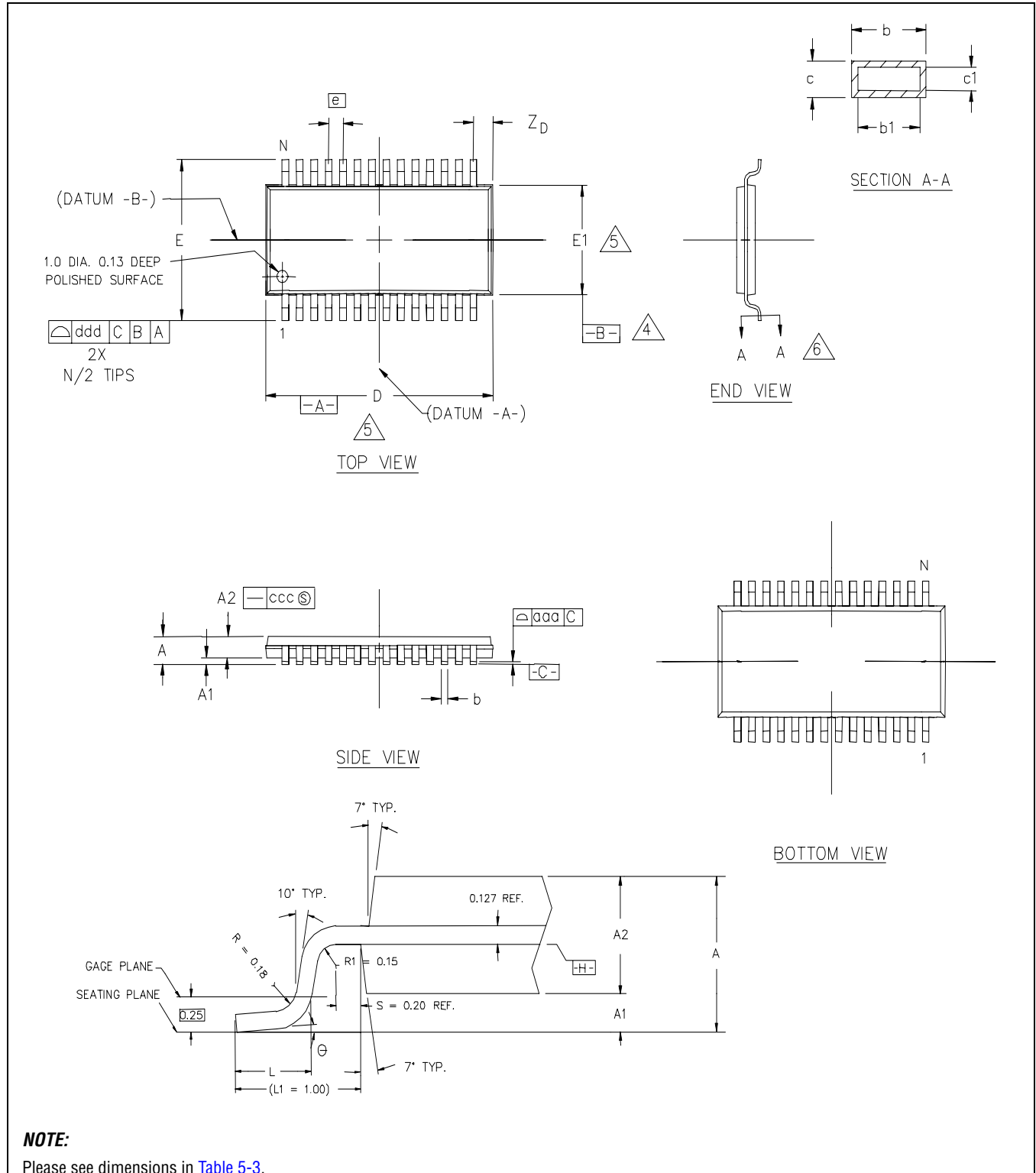

Table 5-3. TSSOP20 Dimensions

Symbol	Tols/leads	TSSOP20L
A	MAX	1.20
A1		0.5MIN/.10MAX.
A2	NOM	.90
D	±.05	6.50
E	±.10	6.40
E1	±.10	4.40
L	+.15/-.10	.60
L1	REF.	1.00
Zp	REF.	.325
e	BASIC	.65
b	±.05	.22
c		.13MIN/.20MAX
e	±4°	4°
aaa	MAX.	.10
bbb	MAX.	.10
ccc	MAX	.05
ddd	MAX.	.20

5.2 Die Specification

Figure 5-5. Bare Die Information

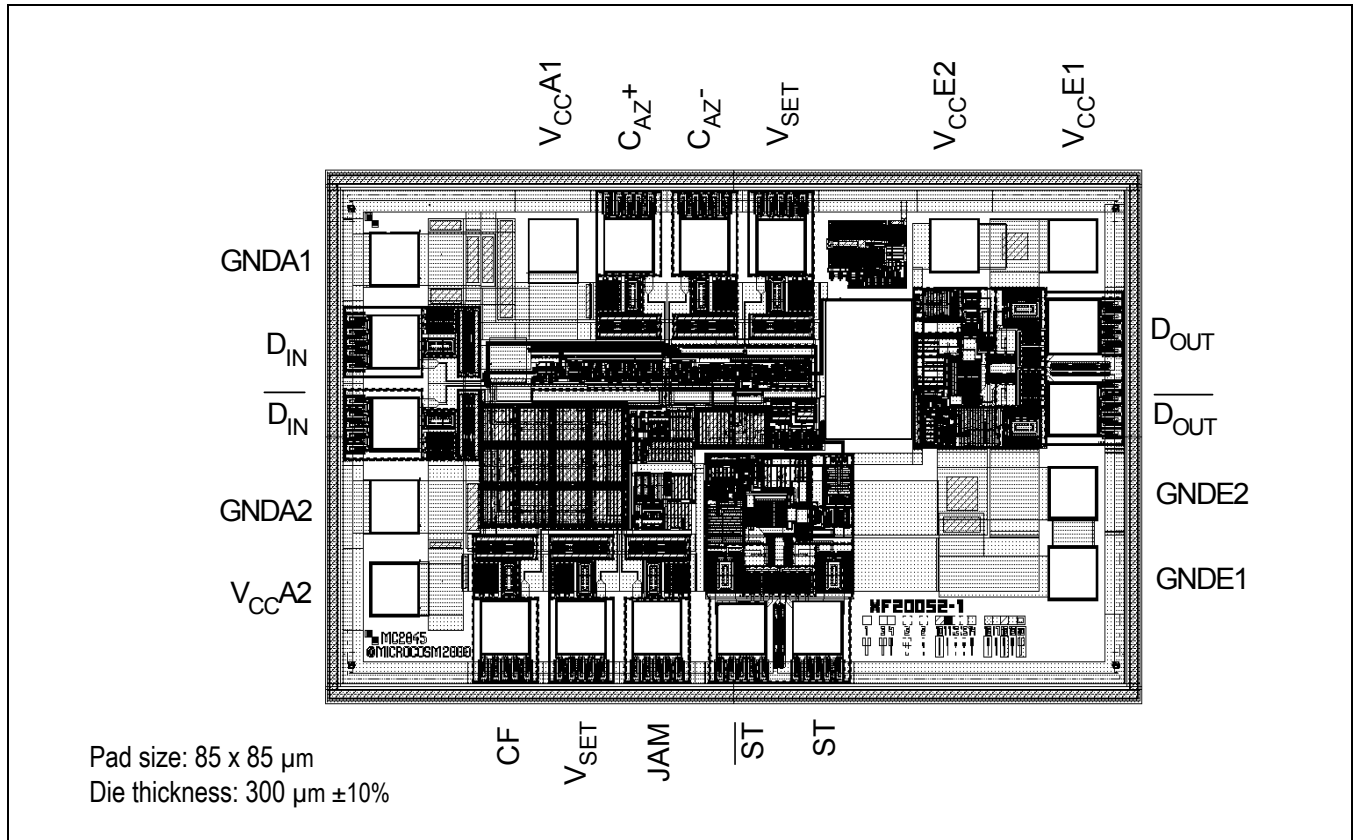

Table 5-4. Pad Centers

Description	X	Y	Description	X	Y
C_{AZ^-}	-56.8	347.5	JAM	-152.2	-347.5
C_{AZ^+}	-207	347.5	ST	15.8	-347.5
$V_{CC A1}$	-356.9	347.5	ST	166	-347.5
GNDA1	-670	322.6	GNDE1	670	-248
D_{IN}	-670	172.6	GNDE2	670	-103
D_{IN}	-670	22.4	D_{OUT}	670	50.1
GNDA2	-670	-127.6	D_{OUT}	670	200.3
$V_{CC A2}$	-670	-277.5	$V_{CC E1}$	670	347.5
C_F	-451.4	-347.5	$V_{CC E2}$	436.9	347.5
V_{SET2}	-301.3	-347.5	V_{SET}	93.2	347.5

NOTE:

Pad coordinates are in μm , and are measured from the center of the die to the center of the pad.

© 2005, Mindspeed Technologies™, Inc. All rights reserved.

Information in this document is provided in connection with Mindspeed Technologies™ ("Mindspeed™") products. These materials are provided by Mindspeed as a service to its customers and may be used for informational purposes only. Except as provided in Mindspeed's Terms and Conditions of Sale for such products or in any separate agreement related to this document, Mindspeed assumes no liability whatsoever. Mindspeed assumes no responsibility for errors or omissions in these materials. Mindspeed may make changes to specifications and product descriptions at any time, without notice. Mindspeed makes no commitment to update the information and shall have no responsibility whatsoever for conflicts or incompatibilities arising from future changes to its specifications and product descriptions. No license, express or implied, by estoppel or otherwise, to any intellectual property rights is granted by this document.

THESE MATERIALS ARE PROVIDED "AS IS" WITHOUT WARRANTY OF ANY KIND, EITHER EXPRESS OR IMPLIED, RELATING TO SALE AND/OR USE OF MINDSPEED PRODUCTS INCLUDING LIABILITY OR WARRANTIES RELATING TO FITNESS FOR A PARTICULAR PURPOSE, CONSEQUENTIAL OR INCIDENTAL DAMAGES, MERCHANTABILITY, OR INFRINGEMENT OF ANY PATENT, COPYRIGHT OR OTHER INTELLECTUAL PROPERTY RIGHT. MINDSPEED FURTHER DOES NOT WARRANT THE ACCURACY OR COMPLETENESS OF THE INFORMATION, TEXT, GRAPHICS OR OTHER ITEMS CONTAINED WITHIN THESE MATERIALS. MINDSPEED SHALL NOT BE LIABLE FOR ANY SPECIAL, INDIRECT, INCIDENTAL, OR CONSEQUENTIAL DAMAGES, INCLUDING WITHOUT LIMITATION, LOST REVENUES OR LOST PROFITS, WHICH MAY RESULT FROM THE USE OF THESE MATERIALS.

Mindspeed products are not intended for use in medical, lifesaving or life sustaining applications. Mindspeed customers using or selling Mindspeed products for use in such applications do so at their own risk and agree to fully indemnify Mindspeed for any damages resulting from such improper use or sale.

www.mindspeed.com

General Information:
U.S. and Canada: (800) 854-8099
International: (949) 483-6996
Headquarters - Newport Beach
4000 MacArthur Blvd., East Tower
Newport Beach, CA. 92660