



Chipsmall Limited consists of a professional team with an average of over 10 year of expertise in the distribution of electronic components. Based in Hongkong, we have already established firm and mutual-benefit business relationships with customers from,Europe,America and south Asia,supplying obsolete and hard-to-find components to meet their specific needs.

With the principle of “Quality Parts,Customers Priority,Honest Operation,and Considerate Service”,our business mainly focus on the distribution of electronic components. Line cards we deal with include Microchip,ALPS,ROHM,Xilinx,Pulse,ON,Everlight and Freescale. Main products comprise IC,Modules,Potentiometer,IC Socket,Relay,Connector.Our parts cover such applications as commercial,industrial, and automotives areas.

We are looking forward to setting up business relationship with you and hope to provide you with the best service and solution. Let us make a better world for our industry!



Contact us

Tel: +86-755-8981 8866 Fax: +86-755-8427 6832

Email & Skype: info@chipsmall.com Web: www.chipsmall.com

Address: A1208, Overseas Decoration Building, #122 Zhenhua RD., Futian, Shenzhen, China



M0220MD-202MDAR1-1

Dot-matrix Character Vacuum Fluorescent Display Module

M-	VFD Module
0220-	2 lines x 20 characters
M-	Model
D-	Dot-Matrix
202MDA-	Character size = 3.68mm x 8.78mm
R-	RoHS Compliant
1-1	Serial interface

Newhaven Display International, Inc.

2511 Technology Drive, Suite 101

Elgin IL, 60124

Ph: 847-844-8795

Fax: 847-844-8796

www.newhavendisplay.com

nhtech@newhavendisplay.com

nhsales@newhavendisplay.com

Document Revision History

Revision	Date	Description	Changed by
0	3/21/2005	Initial Release	
1	9/21/2009	Updated Driver version, modified vf glass pins	CL
2	12/4/2009	Reduce pixel size to increase brightness and lifetime	CL

Functions and Features

- 2 lines x 20 characters
- Built-in controller
- Built-in VF AC power supply
- 5.0V power supply
- 5x8 dots with cursor
- Serial interface (parallel interface selectable by jumpers)

Mechanical Drawing

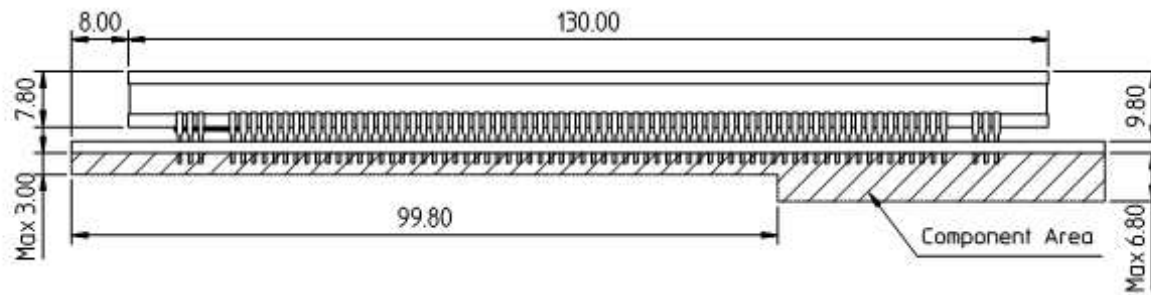
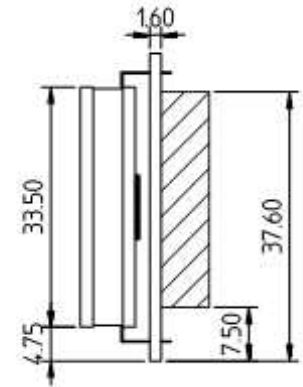
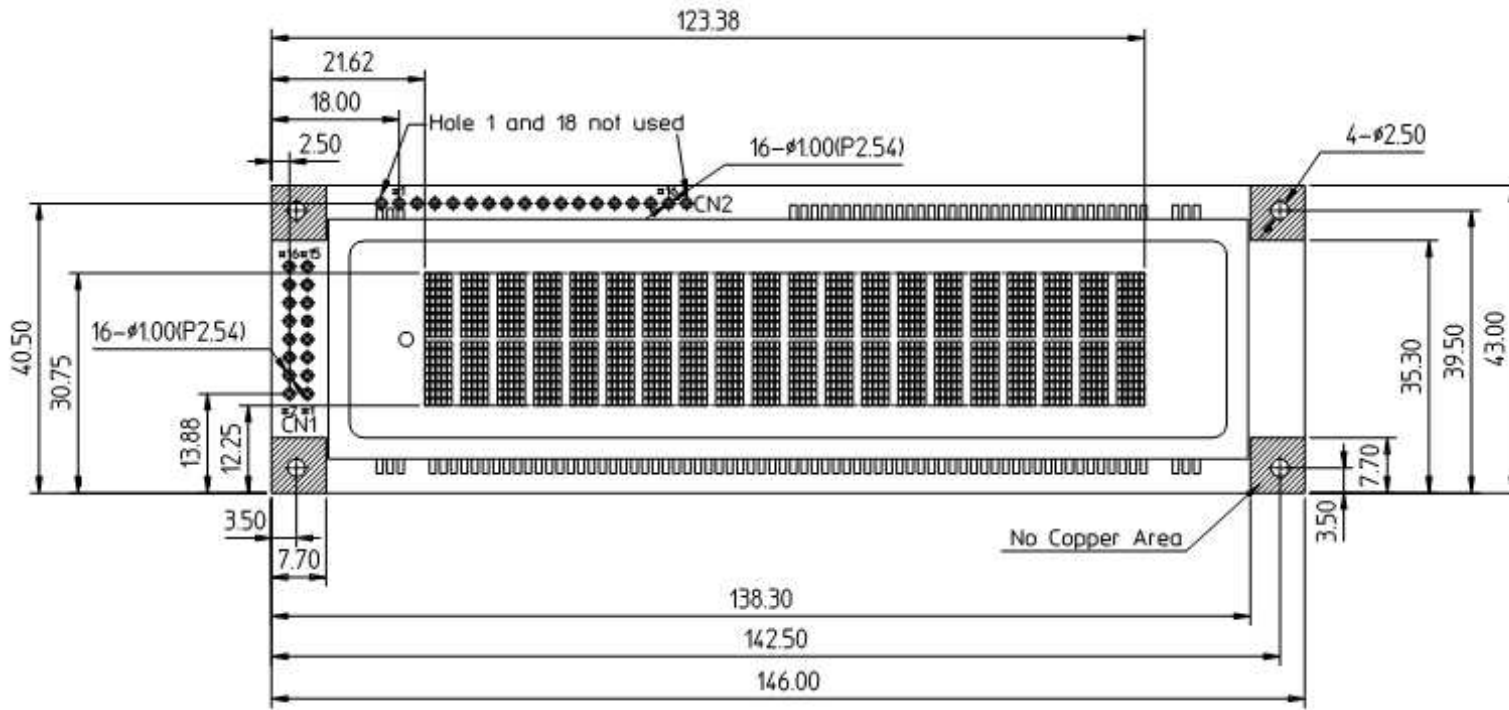

- Unit: mm
- Tolerances unless otherwise specified:
 - Mount Hole Size: +/-0.3
 - Others:
 - Length < 10.0: +/-0.5
 - Length ≥ 10.0: +/-1.0

Pattern Detail

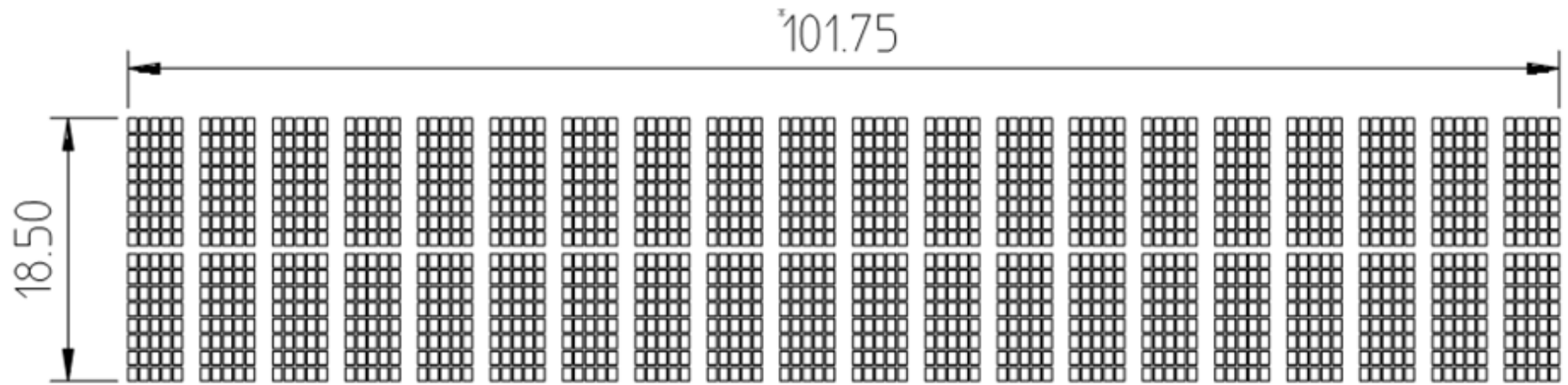

◎ Color of Illumination ◎

· Green (G. :x=0.250,y=0.439) ----- All Patterns.

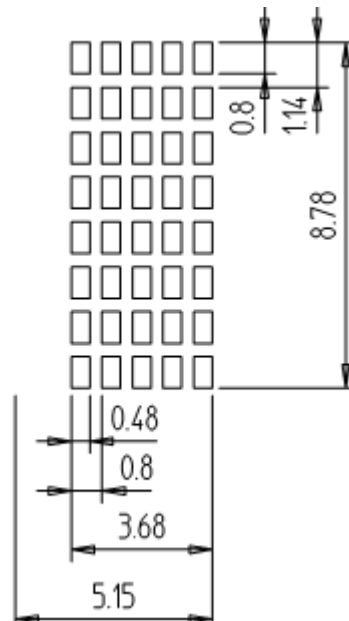

Pin Description (serial interface)

Pin No.	Symbol	External Connection	Function Description
1	VSS	Power Supply	Ground
2	VDD	Power Supply	Power supply for logic (+5.0V)
3	SI/SO	MPU	Serial Data In, data out
4	STB	MPU	Serial Strobe signal
5	NC	-	No Connect
6	SCK	MPU	Serial Clock signal
7-16	NC	-	No Connect

Recommended LCD connector: 2.54mm pitch pins

Pin Description (optional parallel interface)

Pin No.	Symbol	External Connection	Function Description
1	VSS	Power Supply	Ground
2	VDD	Power Supply	Power supply for logic (+5.0V)
3	NC (/RST)	- (MPU)	No Connect (if JP2 is short, PIN3 = Active LOW reset signal)
4	RS	MPU	Register select signal RS=1: DATA RS=0: COMMAND
5	R/W	MPU	Read/Write select signal RW=1: READ RW=0: WRITE
6	E	MPU	Operation enable signal Falling Edge Triggered
7-10	DB0 – DB3	MPU	Four low order bi-directional three-state data bus lines. These four are not used during 4-bit operation
11-14	DB4 – DB7	MPU	Four high order bi-directional three-state data bus lines.

Jumper Settings (Default Serial mode)

Mode	JP2	JP3	JP4	JP5	JP6	JP7
Serial	Open	Short	Open	Short	Open	Short
Parallel (I80)	*1	Open	Short	Open	Open	Short
Parallel (M68)	*1	Open	Short	Open	Short	Open

*1) JP2 short enables PIN3 as external reset. JP2 open disables reset.

Block Diagram

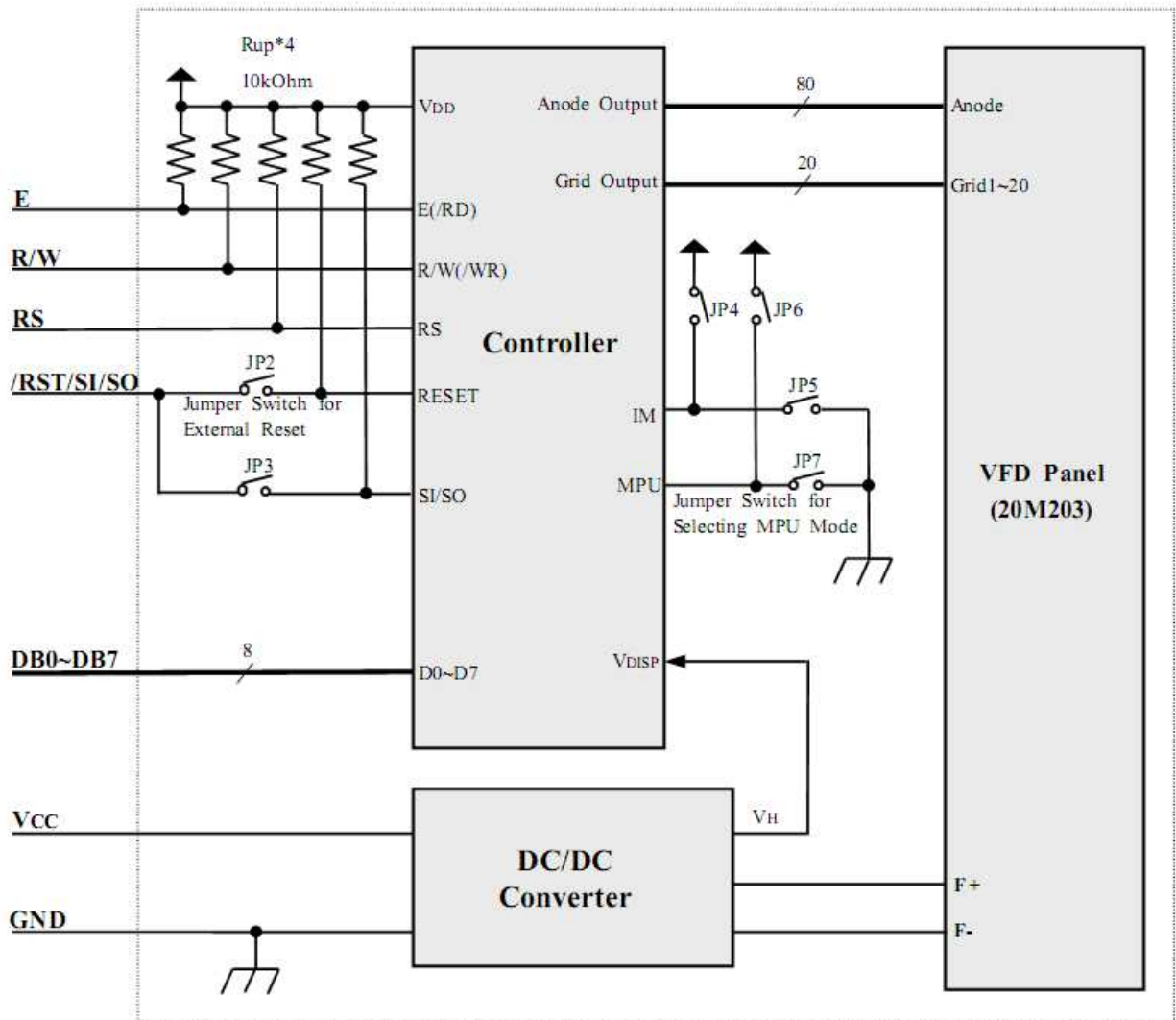

Electrical Characteristics

Item	Symbol	Condition	Min.	Typ.	Max.	Unit
Operating Temperature Range	Vop		-40	-	+85	°C
Storage Temperature Range	Vst		-50	-	+95	°C
Operating Humidity	Hop		0	-	85	%
Storage Humidity	Hst		0	-	90	%
Vibration	-	10~55Hz	-	-	4	G
Shock	-		-	-	40	G
Supply Voltage	VDD		4.5	5.0	5.5	V
Supply Current (*Note)	IDD	Ta=25°C VDD=5.0V	-	290	435	mA
Luminance	L		350	500	-	cd/m ²
"H" Level input	Vih		2.2	-	VDD	V
"L" Level input	Vil		0	-	0.6	V
"H" Level output	Voh		2.4	-	-	V
"L" Level output	Vol		-	-	0.4	V

*Note: In-rush current can be approx 10 times the specified supply current at power up.

Power-on Timing

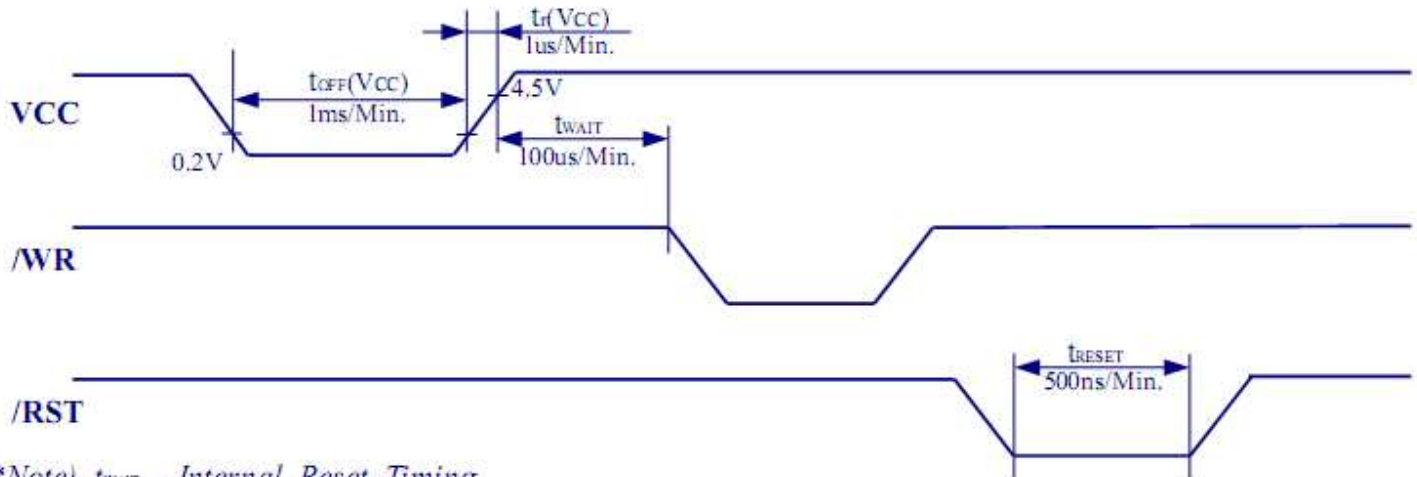

*Note) t_{WAIT} - Internal Reset Timing

Controller Information

Built-in PT6314 controller. Download specification at http://www.newhavendisplay.com/app_notes/PT6314.pdf

Table of Commands

Instructions	Control		Instruction Code								Descriptions	
	RS	R/W	D7	D6	D5	D4	D3	D2	D1	D0		
Display Clear	0	0	0	0	0	0	0	0	0	0	1	Clears all display and sets DD-RAM address 0 in address counter.
Cursor Home	0	0	0	0	0	0	0	0	0	1	*	Sets DD-RAM address 0 in ACC. Also returns the display being shifted to the original position. DD-RAM contents remain unchanged.
Entry Mode Set	0	0	0	0	0	0	0	0	1	I/D	S	Sets the cursor direction and specifies display shift. These operations are performed during writing/reading data.
Display ON/OFF Control	0	0	0	0	0	0	1	D	C		B	Sets all display ON/OFF (D), cursor ON/OFF (C), cursor blink of character position (B).
Cursor or Display Shift	0	0	0	0	0	1	S/C	R/L	*	*	*	Shifts display or cursor, keeping DD-RAM contents.
Function Set	0	0	0	0	1	IF	N	*	BR1	BR0		Sets data length (IF), number of display lines(N), Set brightness level(BR1,BR0)
CG-RAM Address Set	0	0	0	1	ACG (CG-RAM Address)						Sets the CG-RAM address.	
DD-RAM Address Set	0	0	1	ADD (DD-RAM Address)						Sets the DD-RAM address.		
Busy Flag and Address Counter Reading	0	1	BF	ACC (Address Counter)						Reads busy flag (BF) and address counter (ACC).		
Data Writing to CG- or DD-RAM	1	0	Character Code						Writes data into CG-RAM or DD-RAM.			
Data Reading from CG- or DD-RAM	1	1	Character Code						Reads data from CG-RAM or DD-RAM.			
REMARKS:	* I/D = 1: Increment * I/D = 0: Decrement								* IF = 1: 8-bit Operation * IF = 0: 4-bit Operation			
* DD-RAM: Display Data RAM	* S = 1: Display Shift Enabled * S = 0: Cursor Shift Enabled								* N = 1: 2 Lines Display * N = 0: 1 Line Display			
* CG-RAM: Character Generator RAM	* S/C = 1: Display Shift * S/C = 0: Cursor Move								* BR1, BR0 = 00: 100%, 01: 75%, 10: 50%, 11: 25%			
* ACC: CG-RAM Address	* R/L = 1: Shift to the Right * R/L = 0: Shift to the Left								* BF = 1: Busy (Internally operating) * BF = 0: Not busy (Instruction acceptable)			

Display character address code:

	1st Column	2nd Column	3rd Column	19th Column	20th Column
1st ROW	00 Hex	01 Hex	02 Hex	12 Hex	13 Hex
2nd ROW	40 Hex	41Hex	42 Hex	52 Hex	53 Hex

Serial Interface:

Data can only be written when STB is LOW.

The first byte (Start byte) consists of 8 bits. Bits 1 through 5 are Synchronous bits, bit 6 is R/W, bit 7 is RS, bit 8 is LOW.

R/W is HIGH to read from the display, or LOW to write data to the display.

RS is HIGH to read/write Data, or LOW to read/write an Instruction.

The following byte or bytes is the 8-bit instruction or data sent to/from the display.

Serial Data Write:

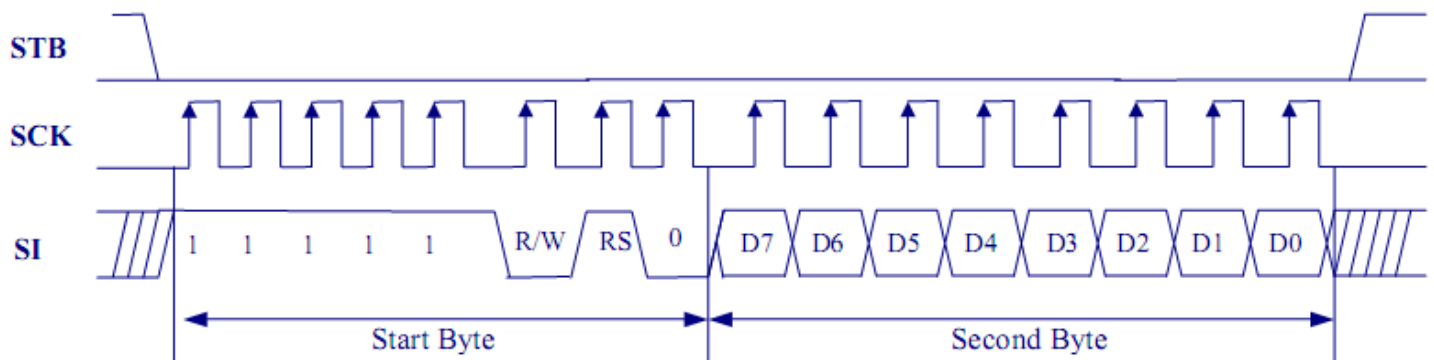

Serial Data Read:

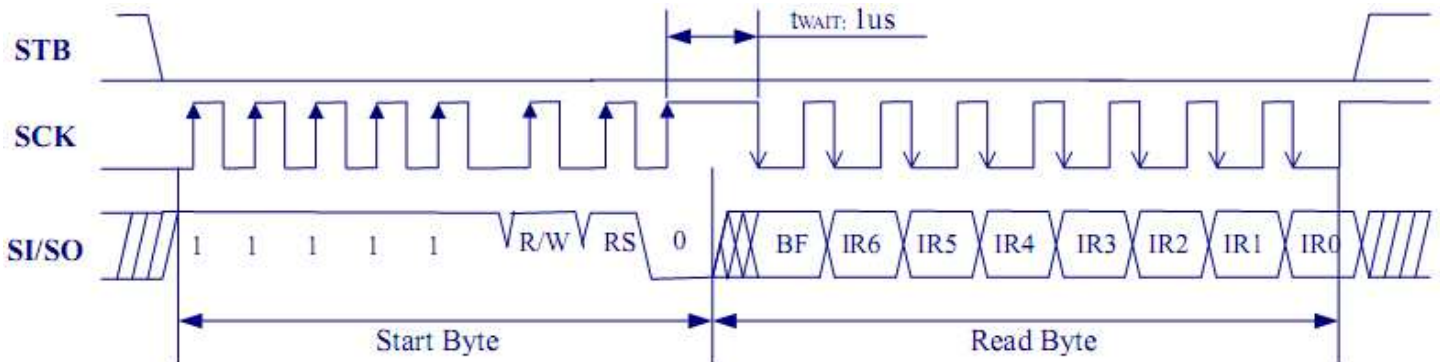

Serial Write Timing:

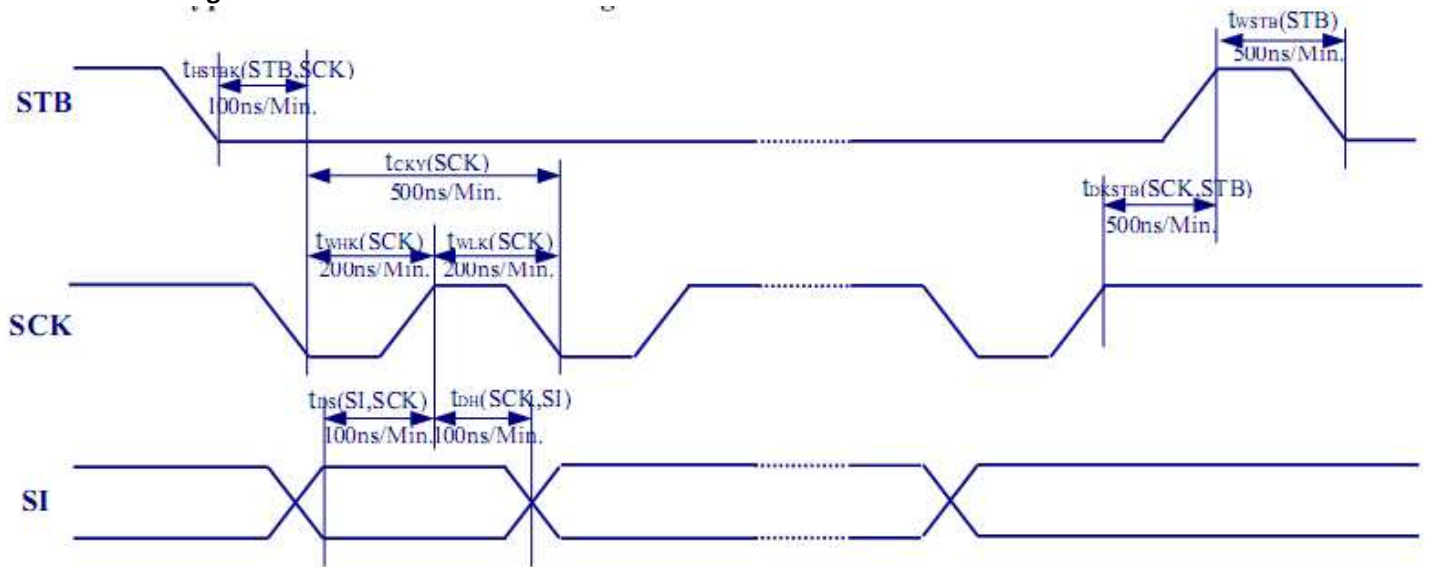

Serial Read Timing:

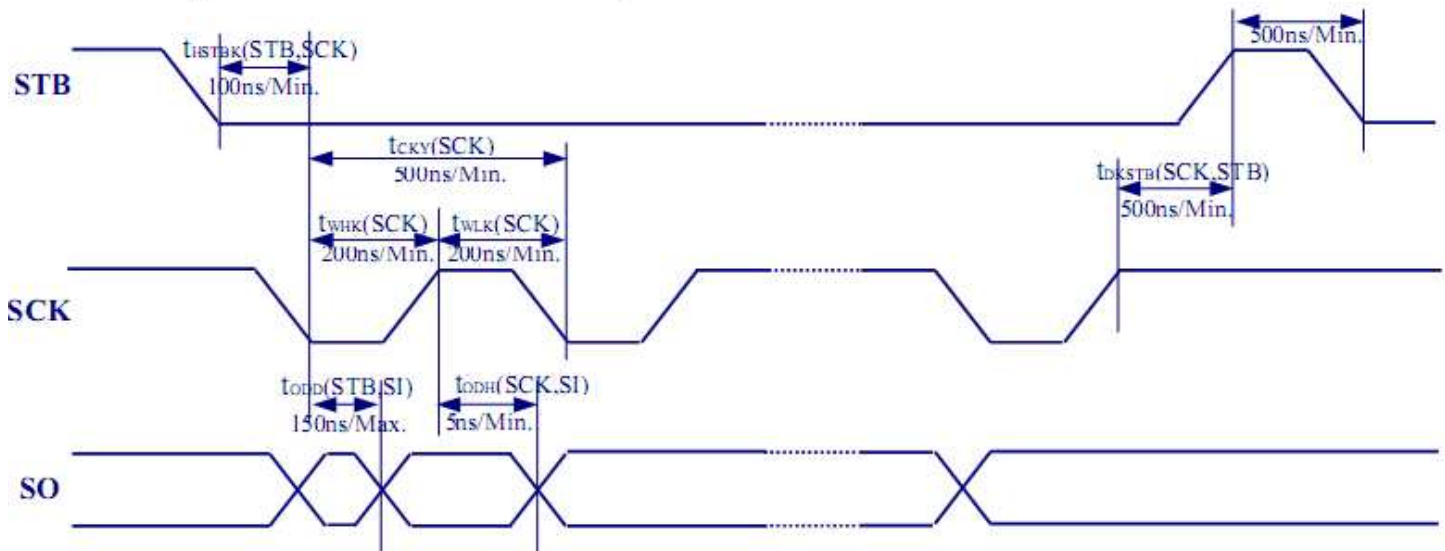

Built-in Font Table

		Upper Nibble				Lower Nibble																
		D7	D6	D5	D4	0	1	2	3	4	5	6	7	8	9	A	B	C	D	E	F	
Upper Nibble	Lower Nibble	D3	D2	D1	D0	0	1	2	3	4	5	6	7	8	9	A	B	C	D	E	F	
0	0	0	0	0	0	CC-RAM (#1)																
0	0	0	1	1	1	CC-RAM (#2)																
0	0	1	0	1	1	CC-RAM (#3)																
0	0	1	1	0	0	CC-RAM (#4)																
0	1	0	0	0	0	CC-RAM (#5)																
0	1	0	1	0	0	CC-RAM (#6)																
0	1	1	0	0	0	CC-RAM (#7)																
0	1	1	1	0	0	CC-RAM (#8)																
1	0	0	0	0	0	CC-RAM (#1)																
1	0	0	1	0	0	CC-RAM (#2)																
1	0	1	0	0	0	CC-RAM (#3)																
1	0	1	1	0	0	CC-RAM (#4)																
1	1	0	0	0	0	CC-RAM (#5)																
1	1	0	1	0	0	CC-RAM (#6)																
1	1	1	0	0	0	CC-RAM (#7)																
1	1	1	1	0	0	CC-RAM (#8)																

Example Initialization after Power ON

RS	R/W	DB7	DB6	DB5	DB4	DB3	DB2	DB1	DB0	Description
Power ON										Wait for 100 us
0	0	0	0	1	1	1	*	0	0	Function set: - Data length: 8 bits - Display line No.: 2 lines - Brightness: 100%
0	0	0	1	0	0	0	0	0	0	CG-RAM address set to 00H
1	0	*	*	*	D	D	D	D	D	Writes data into CG-RAM (the user-definable characters) 64 bytes in total (8 characters)
									
		*	*	*	D	D	D	D	D	
0	0	1	0	0	0	0	0	0	0	DD-RAM address set to 00H (the first column of upper line)
1	0	D	D	D	D	D	D	D	D	Writes data into DD-RAM (choose the character codes to display in upper line) Totally 20 bytes in the upper line (20 characters)
									
		D	D	D	D	D	D	D	D	
0	0	1	1	0	0	0	0	0	0	DD-RAM address set to 40H (the first column of lower line)
1	0	D	D	D	D	D	D	D	D	Writes data into DD-RAM (choose the character codes to display in lower line) Totally 20 bytes in the lower line (20 characters)
									
		D	D	D	D	D	D	D	D	
0	0	0	0	0	0	1	1	0	0	Display ON, Cursor OFF, Cursor blink OFF

*Note): D is the binary data to be written-in.

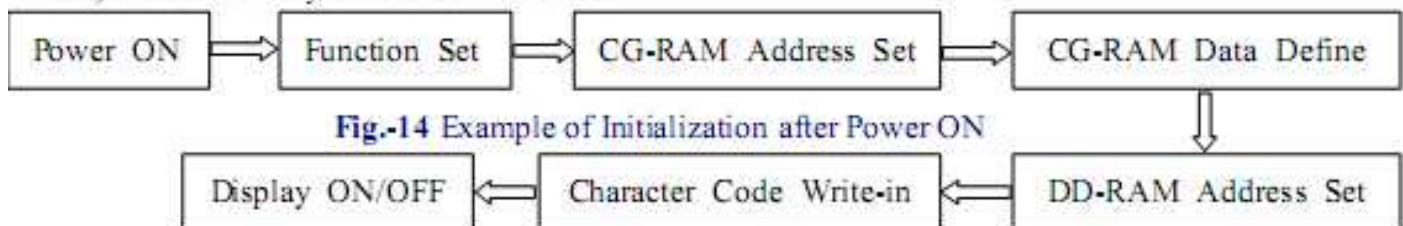

Fig.-14 Example of Initialization after Power ON

Quality Information

Test Item	Content of Test	Test Condition	Note
High Temperature storage	Endurance test applying the high storage temperature for a long time.	+80°C , 48hrs	2
Low Temperature storage	Endurance test applying the low storage temperature for a long time.	-30°C , 48hrs	1,2
High Temperature Operation	Endurance test applying the electric stress (voltage & current) and the high thermal stress for a long time.	+70°C 48hrs	2
Low Temperature Operation	Endurance test applying the electric stress (voltage & current) and the low thermal stress for a long time.	-20°C , 48hrs	1,2
High Temperature / Humidity Operation	Endurance test applying the electric stress (voltage & current) and the high thermal with high humidity stress for a long time.	+40°C , 90% RH , 48hrs	1,2
Thermal Shock resistance	Endurance test applying the electric stress (voltage & current) during a cycle of low and high thermal stress.	0°C,30min -> +25°C,5min -> +50°C,30min = 1 cycle 10 cycles	
Vibration test	Endurance test applying vibration to simulate transportation and use.	10-55Hz , 15mm amplitude. 60 sec in each of 3 directions X,Y,Z For 15 minutes	3
Static electricity test	Endurance test applying electric static discharge.	VS=800V, RS=1.5kΩ, CS=100pF One time	

Note 1: No condensation to be observed.

Note 2: Conducted after 4 hours of storage at 25°C, 0%RH.

Note 3: Test performed on product itself, not inside a container.

Precautions for using LCDs/LCMs

See Precautions at www.newhavendisplay.com/specs/precautions.pdf

Warranty Information and Terms & Conditions

http://www.newhavendisplay.com/index.php?main_page=terms