



Chipsmall Limited consists of a professional team with an average of over 10 year of expertise in the distribution of electronic components. Based in Hongkong, we have already established firm and mutual-benefit business relationships with customers from,Europe,America and south Asia,supplying obsolete and hard-to-find components to meet their specific needs.

With the principle of “Quality Parts,Customers Priority,Honest Operation,and Considerate Service”,our business mainly focus on the distribution of electronic components. Line cards we deal with include Microchip,ALPS,ROHM,Xilinx,Pulse,ON,Everlight and Freescale. Main products comprise IC,Modules,Potentiometer,IC Socket,Relay,Connector.Our parts cover such applications as commercial,industrial, and automotives areas.

We are looking forward to setting up business relationship with you and hope to provide you with the best service and solution. Let us make a better world for our industry!



Contact us

Tel: +86-755-8981 8866 Fax: +86-755-8427 6832

Email & Skype: info@chipsmall.com Web: www.chipsmall.com

Address: A1208, Overseas Decoration Building, #122 Zhenhua RD., Futian, Shenzhen, China



Customer Information Sheet

DRAWING No.: M20-876XXXXR

SHEET 3 OF 4

IF IN DOUBT - ASK



NOT TO SCALE

THIRD ANGLE PROJECTION

ALL DIMENSIONS IN mm

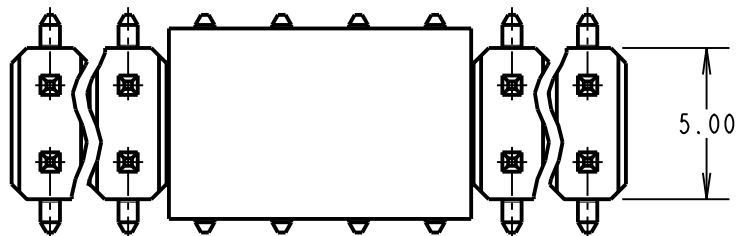

NOTES:

1. FOR 4+4-WAYS AND LESS, CAP LENGTH = 6.00mm.
2. SEE DRAWING M20-876XXXXP FOR PICK AND PLACE VERSION, M20-876XXXX FOR STANDARD PRODUCT.
3. CO-PLANARITY: FLATNESS OF SMT TAILS MUST NOT EXCEED VALUES GIVEN IN TABLE.
4. ALL TOLERANCES ARE ± 0.15 UNLESS OTHERWISE STATED.

SPECIFICATION:

MATERIAL:
 MOULDING = NYLON 6T UL94V-0, BLACK
 CONTACT = BRASS

FINISH:
 42 = SELECTIVE GOLD ON CONTACT AREA,
 100% TIN ON TAILS
 46 = 100% TIN

ELECTRICAL:
 CURRENT RATING = 3A MAX
 CONTACT RESISTANCE = 20 m Ω MAX
 INSULATION RESISTANCE = 500 M Ω MIN
 DIELECTRIC STRENGTH = 1000V AC
 VOLTAGE RATING = 250V AC/DC

MECHANICAL:
 DURABILITY = 50 OPERATIONS (TIN),
 300 OPERATIONS (GOLD)

ENVIRONMENTAL:
 TEMPERATURE RANGE = -40°C TO +105°C

SOLDERING:
 REFLOW TEMP = 260°C FOR 10 SECONDS MAX
 MANUAL TEMP = 330°C FOR 3-5 SECONDS
 FOR COMPLETE SPECIFICATION, SEE COMPONENT SPECIFICATION COOIXX (LATEST ISSUE)

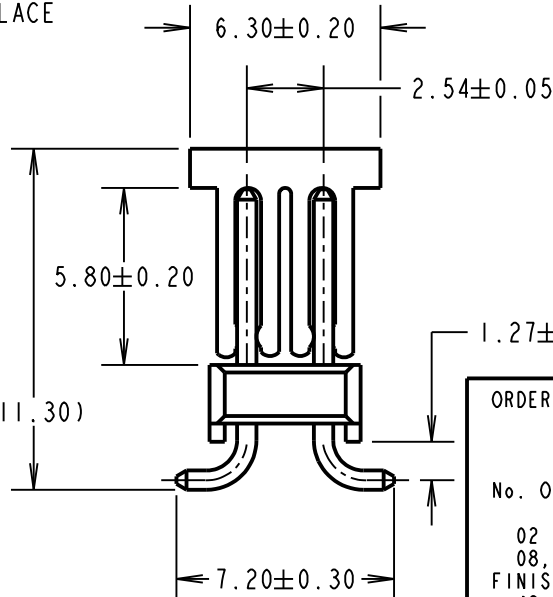
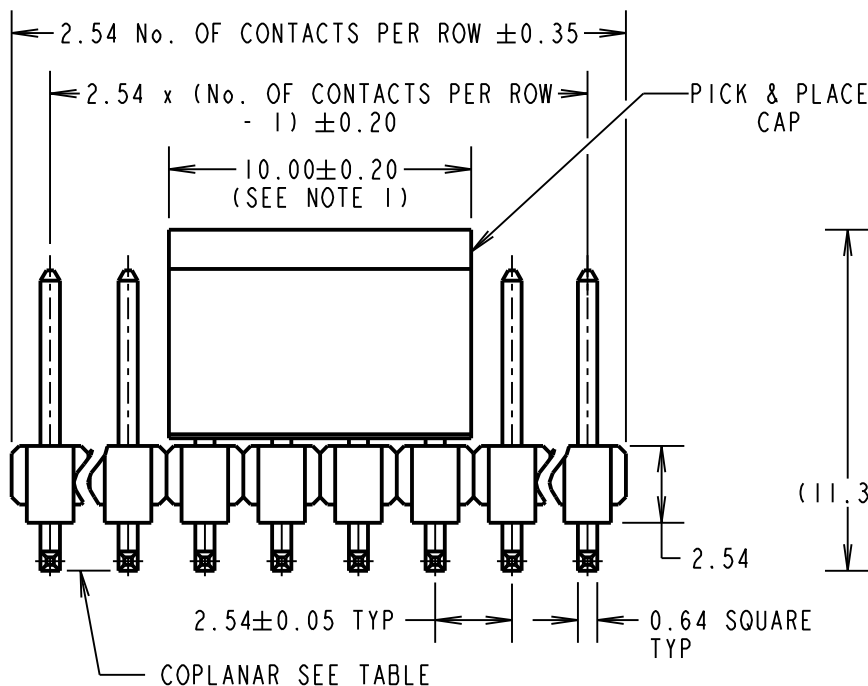

No OF CONTACTS	COPLANARITY TOLERANCE
2x02 TO 2x12	0.10mm MAX
2x13 TO 2x17	0.15mm MAX

ORDER CODE:
M20-876XXXXR

No. OF CONTACTS PER ROW:
 02, 03, 04, 05, 07,
 08, 10, 17

FINISH:
 42 = SELECTIVE GOLD + 100% TIN
 46 = 100% TIN

MS	14	25.11.16	20172
NAME	ISS.	DATE	C/NOTE
APPROVED: M.PERREN			
CHECKED: S.BENNETT			
DRAWN: W. J. BOURNE			
CUSTOMER REF.:			
ASSEMBLY DRG:			

HARWIN

www.harwin.com
 technical@harwin.com

THIS DRAWING AND ANY INFORMATION OR DESCRIPTIVE MATTER SET OUT HEREON ARE CONFIDENTIAL AND COPYRIGHT PROPERTY OF THE HARWIN GROUP AND MUST NOT BE DISCLOSED, LOANED, COPIED OR USED FOR MANUFACTURING, TENDERING OR FOR ANY OTHER PURPOSE WITHOUT THEIR WRITTEN PERMISSION.

TOLERANCES
~~X. = ± 1 mm~~
~~X.X = ± 0.50 mm~~
~~X.XX = ± 0.10 mm~~
~~X.XXX = ± 0.01 mm~~
 ANGLES = $\pm 5^\circ$
 UNLESS STATED

MATERIAL:
 SEE ABOVE

FINISH:
 SEE ABOVE

S/AREA:
 mm²

TITLE: 2.54mm PITCH DIL
 SMT PIN HEADER ASSEMBLY
 (WITH P/PLACE CAP, T/REEL)

DRAWING NUMBER:
M20-876XXXXR

SHT
 3
 OF
 4

Customer Information Sheet

DRAWING No.: M20-876XXXXR

SHEET 4 OF 4

IF IN DOUBT - ASK

©

NOT TO SCALE

THIRD ANGLE PROJECTION

ALL DIMENSIONS IN mm

TAPE DETAILS FOR
02, 03 & 04 WAYS

TAPE DETAILS FOR
05, 07, 08, 10 & 17 WAYS

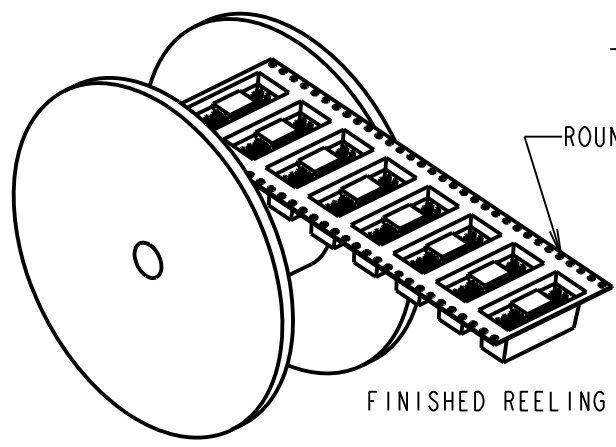
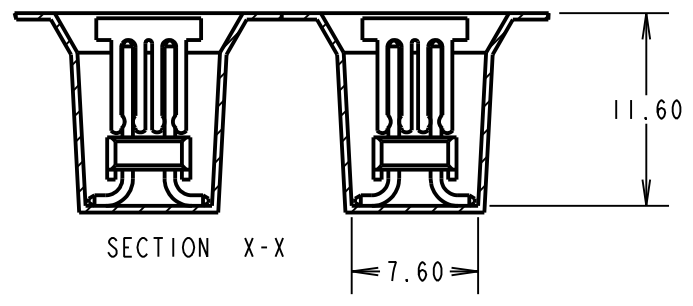
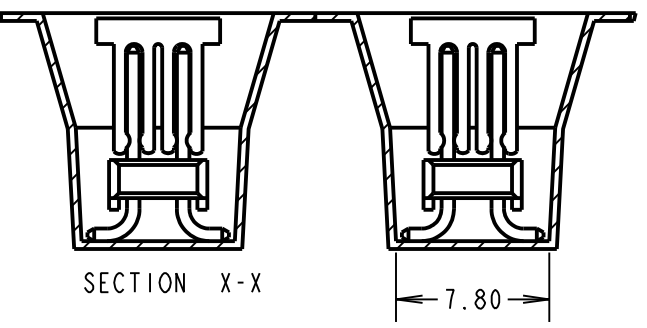
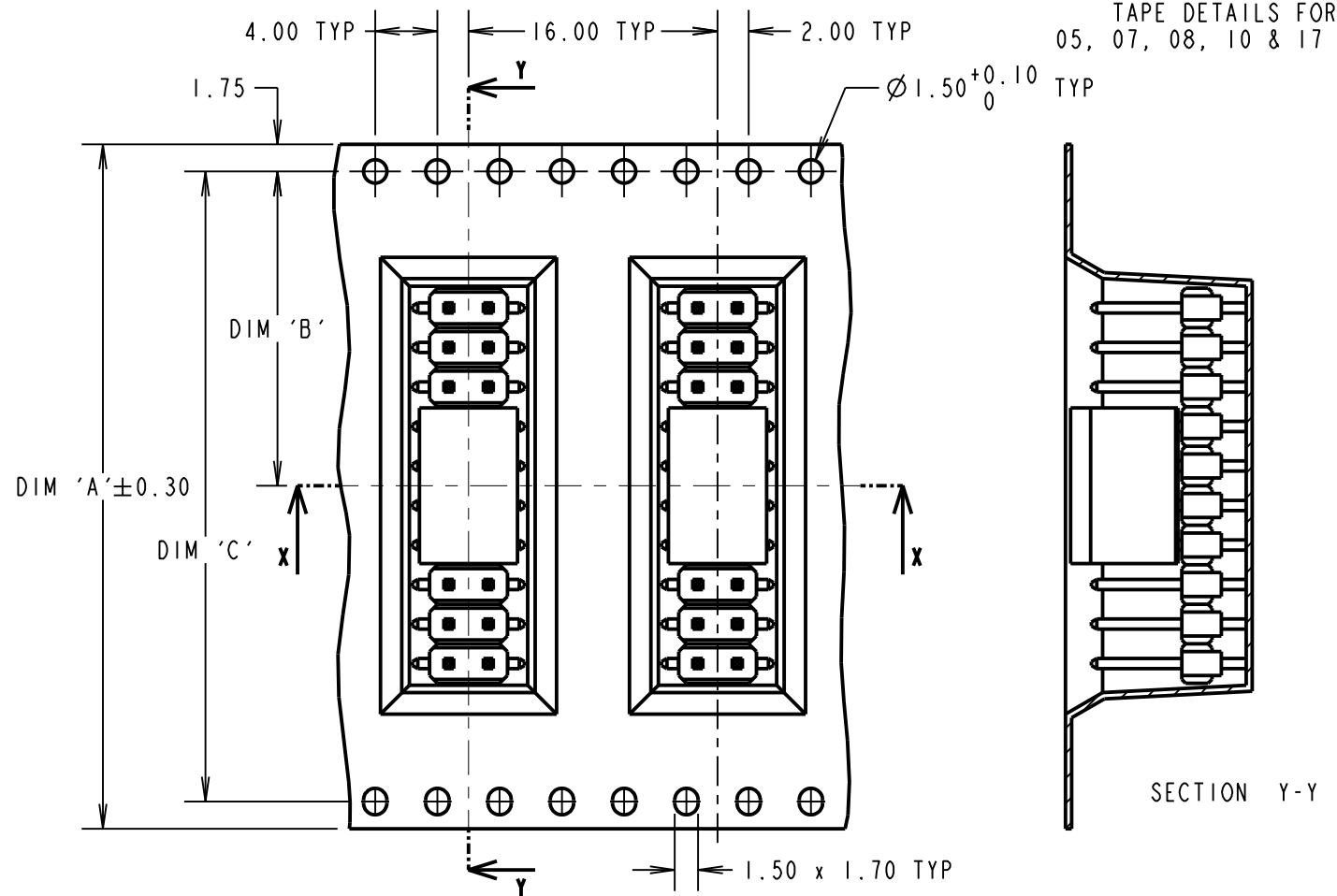
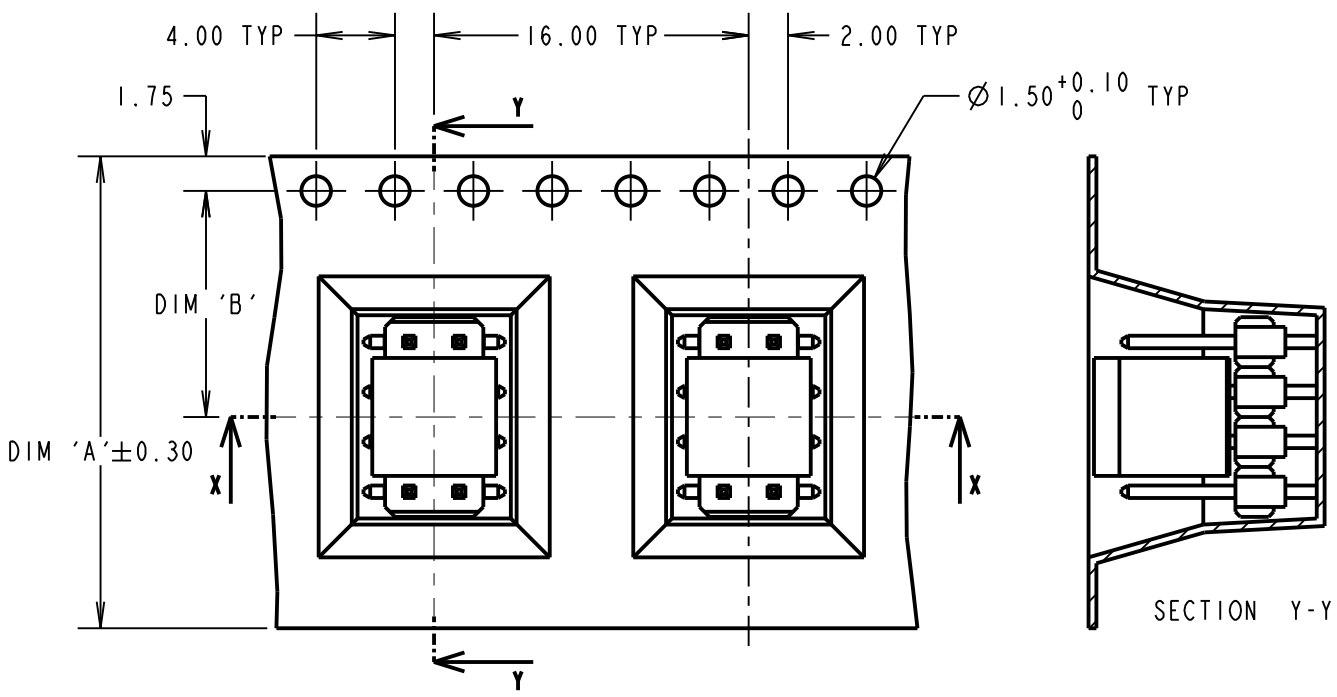

FINISHED REELING DETAILS

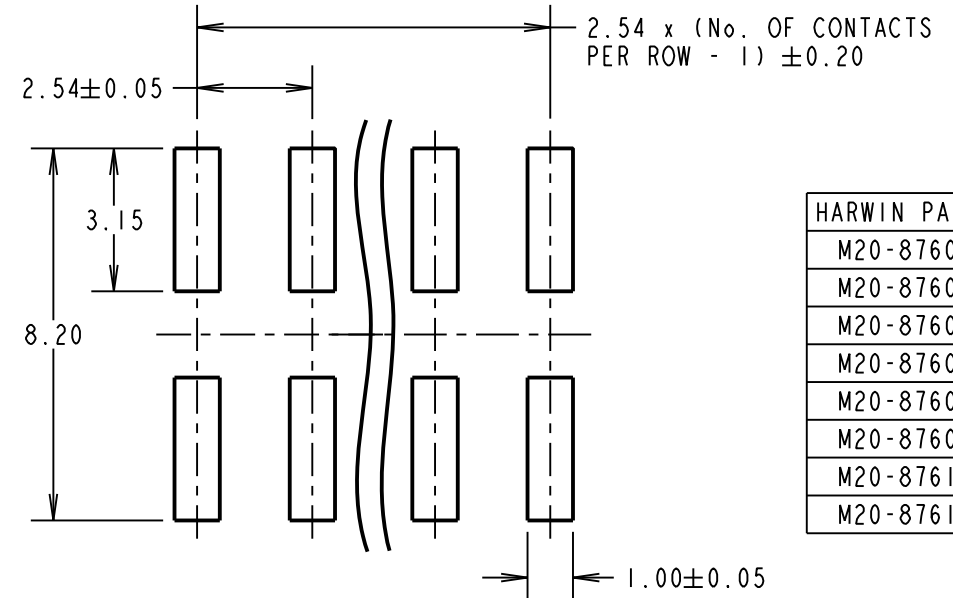

HARWIN PART No.	DIM 'A'	DIM 'B'	DIM 'C'	DIM 'D'
M20-87602XXR				5.80
M20-87603XXR	24.00	11.50		7.80
M20-87604XXR				10.35
M20-87605XXR				12.90
M20-87607XXR	32.00	28.40	14.20	18.00
M20-87608XXR				20.55
M20-87610XXR	44.00	40.40	20.20	25.65
M20-87617XXR	72.00	68.40	34.20	43.60

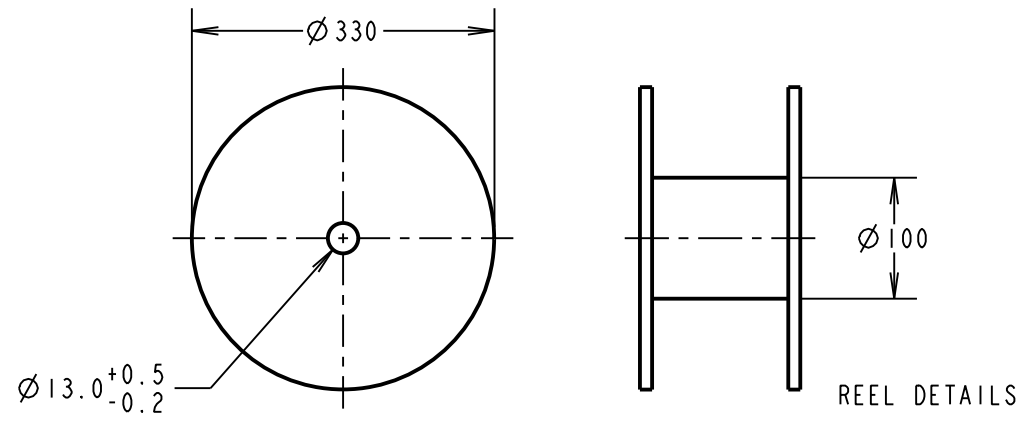

REEL DETAILS

MS	14	25.11.16	20172
NAME	ISS.	DATE	C/NOTE
APPROVED: M. PERREN			
CHECKED: S. BENNETT			
DRAWN: W. J. BOURNE			
CUSTOMER REF.:			
ASSEMBLY DRG:			

- NOTES:
1. QUANTITY PER REEL = 350 PIECES.
 2. FOR CONNECTOR DIMENSIONS AND SPECIFICATIONS, SEE SHEET 3.
 3. TAPE & REELING TO BE IN ACCORDANCE WITH ELECTRONIC INDUSTRIES ASSOCIATION EIA-481.

HARWIN

www.harwin.com
technical@harwin.com

THIS DRAWING AND ANY INFORMATION OR DESCRIPTIVE MATTER SET OUT HEREON ARE CONFIDENTIAL AND COPYRIGHT PROPERTY OF THE HARWIN GROUP AND MUST NOT BE DISCLOSED, LOANED, COPIED OR USED FOR MANUFACTURING, TENDERING OR FOR ANY OTHER PURPOSE WITHOUT THEIR WRITTEN PERMISSION.

TOLERANCES
X. = ±1mm
X.X = ±0.25mm
X.XX = ±0.10mm
X.XXX = ±0.01mm
ANGLES = ±5°
UNLESS STATED

MATERIAL: SEE SHEET 3
FINISH: SEE SHEET 3
S/AREA: mm²

TITLE: 2.54mm PITCH DIL SMT PIN HEADER ASSEMBLY (WITH P/PLACE CAP, T/REEL)
DRAWING NUMBER: M20-876XXXXR
SHT 4 OF 4