



Chipsmall Limited consists of a professional team with an average of over 10 year of expertise in the distribution of electronic components. Based in Hongkong, we have already established firm and mutual-benefit business relationships with customers from,Europe,America and south Asia,supplying obsolete and hard-to-find components to meet their specific needs.

With the principle of “Quality Parts,Customers Priority,Honest Operation,and Considerate Service”,our business mainly focus on the distribution of electronic components. Line cards we deal with include Microchip,ALPS,ROHM,Xilinx,Pulse,ON,Everlight and Freescale. Main products comprise IC,Modules,Potentiometer,IC Socket,Relay,Connector.Our parts cover such applications as commercial,industrial, and automotives areas.

We are looking forward to setting up business relationship with you and hope to provide you with the best service and solution. Let us make a better world for our industry!



Contact us

Tel: +86-755-8981 8866 Fax: +86-755-8427 6832

Email & Skype: info@chipsmall.com Web: www.chipsmall.com

Address: A1208, Overseas Decoration Building, #122 Zhenhua RD., Futian, Shenzhen, China



NOTES:

1. STANDARD PART SET UP AS ASP.
2. Ⓢ REPRESENTS A CRITICAL DIMENSION.
3. MAXIMUM BURR ALLOWANCE: .038 [.0015].
4. MINIMUM PUSHOUT FORCE: 2.22N [.5LB].
5. PARTS TO BE PACKAGED IN TAPE & REEL.

REVISION

A	TP	D FRALEY
1/12/2011	ECN:146422	
RELEASE FOR PRODUCTION		
B	VZ	B ASHLEY
6/30/2014	ECN:231198	
BOM CHG ITEM 4 FROM K-500-300 TOK DOT-236-343-005		

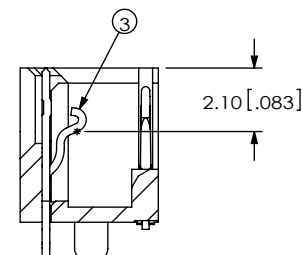
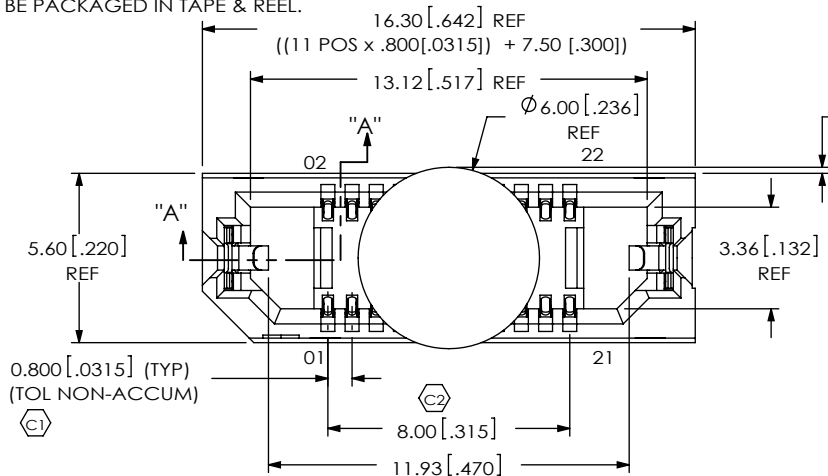

SECTION "A"-"A"
SCALE 4 : 1

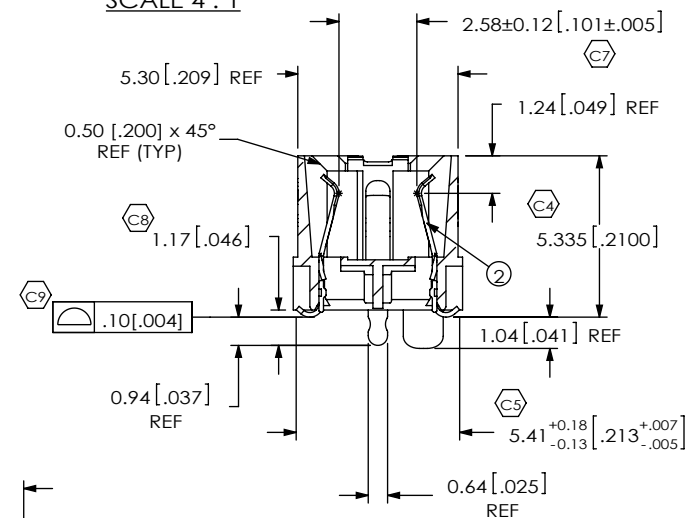
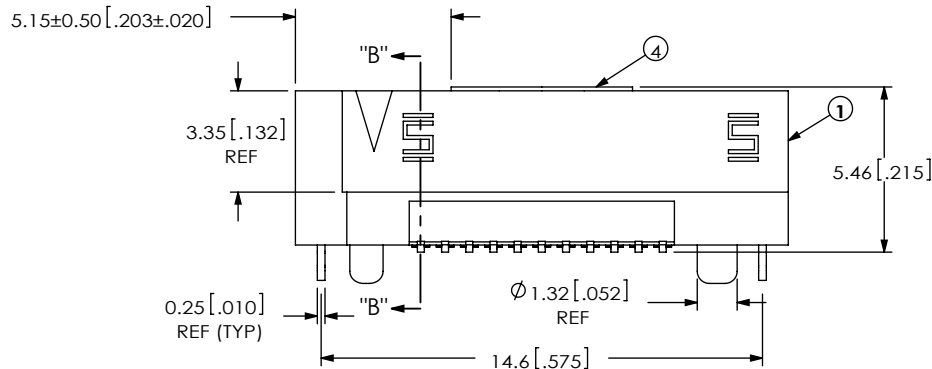

SECTION "B"-"B"
SCALE 4 : 1

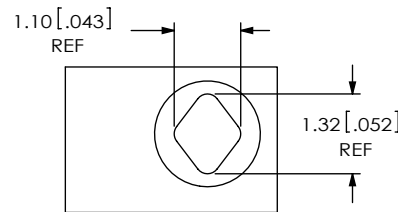
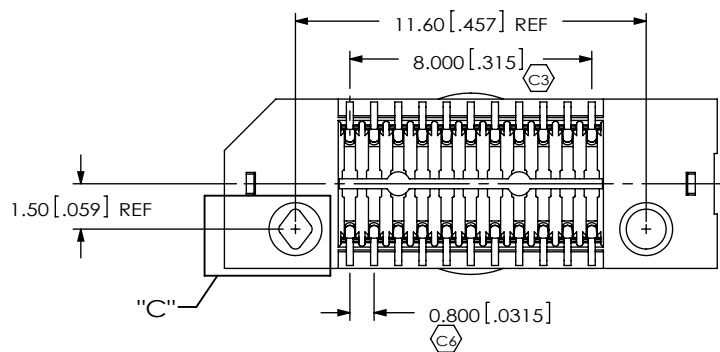

DETAIL "C"
SCALE 8 : 1

ACCEPTANCE OF DRAWING
ACCEPTED WITH DEVIATIONS LISTED

DATE: _____
COMPANY: _____
CUSTOMER SIGNATURE: _____
PRINTED NAME: _____
PHONE NO: _____
FAX NO: _____

UNLESS OTHERWISE SPECIFIED,
DIMENSIONS ARE IN MILLIMETERS.
TOLERANCES ARE:
DECIMALS ANGLES
.X: ±.3[.01] 2°
.XX: ±.13[.005]
.XXX: ±.051[.0020]

PROPRIETARY NOTE
THIS DOCUMENT CONTAINS INFORMATION
CONFIDENTIAL AND PROPRIETARY TO
SAMTEC, INC. AND SHALL NOT BE REPRODUCED
OR TRANSFERRED TO OTHER DOCUMENTS OR
DISCLOSED TO OTHERS OR USED FOR ANY
PURPOSE OTHER THAN THAT WHICH IT WAS
OBTAINED WITHOUT THE EXPRESSED WRITTEN
CONSENT OF SAMTEC, INC.



520 PARK EAST BLVD. NEW ALBANY, IN 47150
PHONE: 812-944-6733 FAX: 812-948-5047
e-Mail info@SAMTEC.com code 55322

DO NOT SCALE DRAWING SHEET SCALE: 1:0.3333
PLATING:
CONTACT AREA: .000030 GOLD OVER .000050 NICKEL
REMAINDER: .000200 REF TIN OVER .000050 NICKEL
LATCHES: .000003 GOLD OVER .000050 NICKEL

DESCRIPTION:
MODIFIED ERF8 ASSEMBLY
DWG. NO.
ASP-137969-02
BY: TIM P. 01/12/2011 SHEET 1 OF 3

ITEM NO.	PART NUMBER	QUANTITY	MATERIAL
1	ERF8-011-05.0-DV-L	1.0000	VECTRA E130i. COLOR: BLACK
2	C-211-05.0-S	22.0000	BeCu. 390 HT
3	WT-30-01-F	2.0000	BeCu. #25, 1/2 HT
4	K-DOT-.236-.343-005	1.0000	POLYIMIDE FILM
5	CT-ERF8034MS	1.0000	CONDUCTIVE POLYMER

B

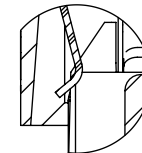
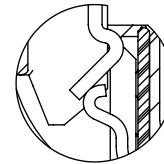
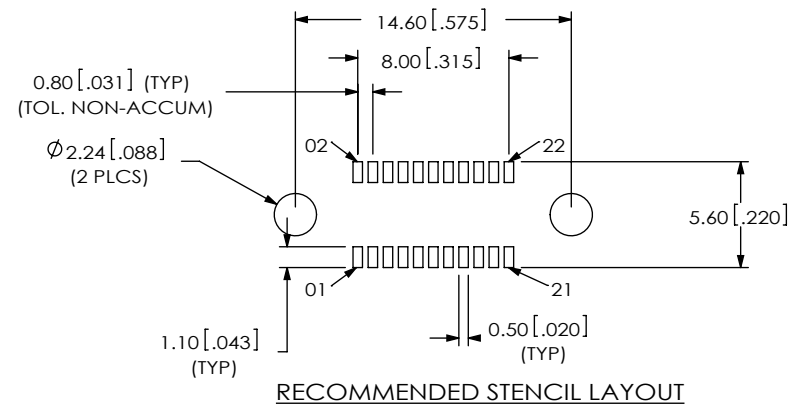
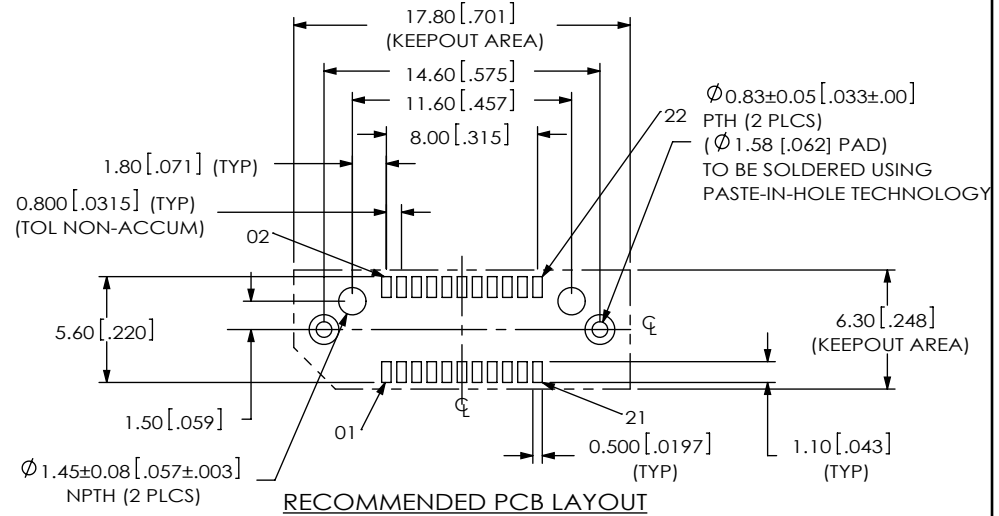
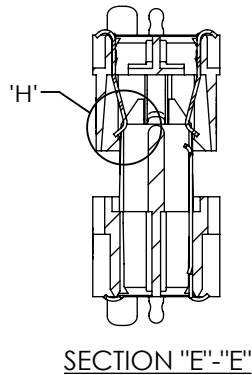
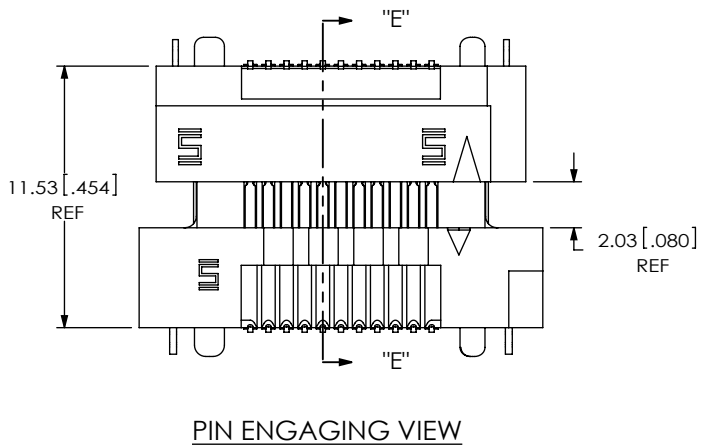
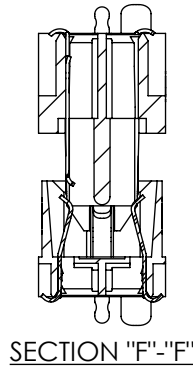
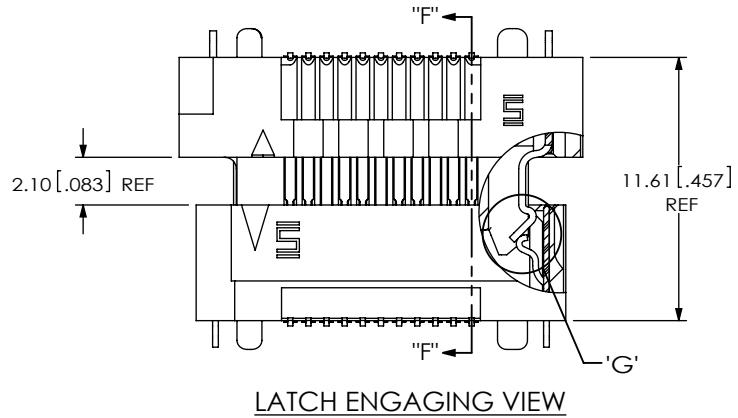

PROPRIETARY NOTE

THIS DOCUMENT CONTAINS INFORMATION CONFIDENTIAL AND PROPRIETARY TO SAMTEC, INC. AND SHALL NOT BE REPRODUCED OR TRANSFERRED TO OTHER DOCUMENTS OR DISCLOSED TO OTHERS OR USED FOR ANY PURPOSE OTHER THAN THAT WHICH IT WAS OBTAINED WITHOUT THE EXPRESSED WRITTEN CONSENT OF SAMTEC, INC.



520 PARK EAST BLVD. NEW ALBANY, IN 47150
PHONE: 812-944-6733 FAX: 812-948-5047
e-Mail info@SAMTEC.com code 55322

SHEET SCALE: 3:1

DESCRIPTION: MODIFIED ERF8 ASSEMBLY

DWG. NO. ASP-137969-02

BY: TIM P. 01/12/2011 SHEET 2 OF 3

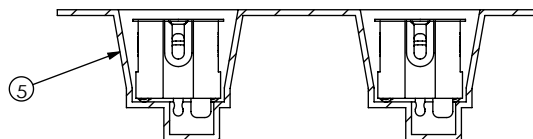
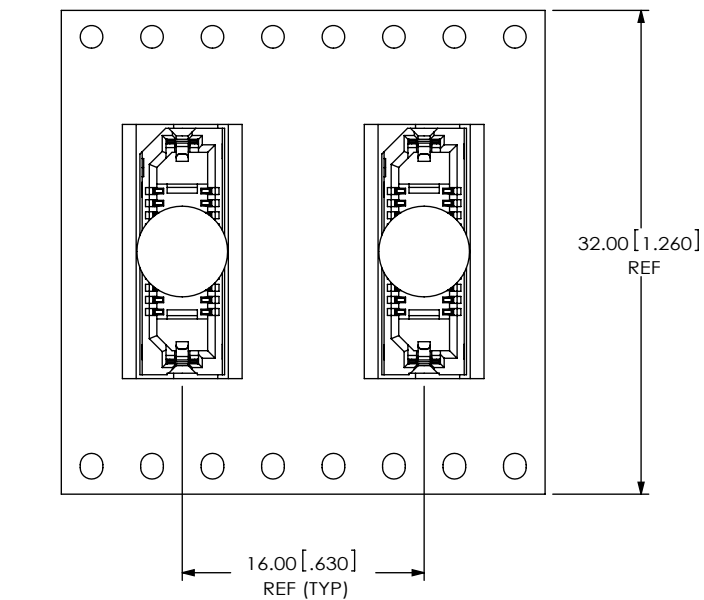

USER DIRECTION OF UNREELING →
POCKET NOT DETAILED

PACKAGING VIEW

PROPRIETARY NOTE

THIS DOCUMENT CONTAINS INFORMATION CONFIDENTIAL AND PROPRIETARY TO SAMTEC, INC. AND SHALL NOT BE REPRODUCED OR TRANSFERRED TO OTHER DOCUMENTS OR DISCLOSED TO OTHERS OR USED FOR ANY PURPOSE OTHER THAN THAT WHICH IT WAS OBTAINED WITHOUT THE EXPRESSED WRITTEN CONSENT OF SAMTEC, INC.

samtec

520 PARK EAST BLVD, NEW ALBANY, IN 47150
PHONE: 812-944-6733 FAX: 812-948-5047
e-Mail: info@SAMTEC.com code 55322

SHEET SCALE: 1:1

DESCRIPTION:
MODIFIED ERF8 ASSEMBLY

DWG. NO.
ASP-137969-02

BY: TIM P. 01/12/2011 SHEET 3 OF 3