



Chipsmall Limited consists of a professional team with an average of over 10 year of expertise in the distribution of electronic components. Based in Hongkong, we have already established firm and mutual-benefit business relationships with customers from,Europe,America and south Asia,supplying obsolete and hard-to-find components to meet their specific needs.

With the principle of “Quality Parts,Customers Priority,Honest Operation,and Considerate Service”,our business mainly focus on the distribution of electronic components. Line cards we deal with include Microchip,ALPS,ROHM,Xilinx,Pulse,ON,Everlight and Freescale. Main products comprise IC,Modules,Potentiometer,IC Socket,Relay,Connector.Our parts cover such applications as commercial,industrial, and automotives areas.

We are looking forward to setting up business relationship with you and hope to provide you with the best service and solution. Let us make a better world for our industry!



Contact us

Tel: +86-755-8981 8866 Fax: +86-755-8427 6832

Email & Skype: info@chipsmall.com Web: www.chipsmall.com

Address: A1208, Overseas Decoration Building, #122 Zhenhua RD., Futian, Shenzhen, China



To our customers,

Old Company Name in Catalogs and Other Documents

On April 1st, 2010, NEC Electronics Corporation merged with Renesas Technology Corporation, and Renesas Electronics Corporation took over all the business of both companies. Therefore, although the old company name remains in this document, it is a valid Renesas Electronics document. We appreciate your understanding.

Renesas Electronics website: <http://www.renesas.com>

April 1st, 2010
Renesas Electronics Corporation

Issued by: Renesas Electronics Corporation (<http://www.renesas.com>)

Send any inquiries to <http://www.renesas.com/inquiry>.

Notice

1. All information included in this document is current as of the date this document is issued. Such information, however, is subject to change without any prior notice. Before purchasing or using any Renesas Electronics products listed herein, please confirm the latest product information with a Renesas Electronics sales office. Also, please pay regular and careful attention to additional and different information to be disclosed by Renesas Electronics such as that disclosed through our website.
2. Renesas Electronics does not assume any liability for infringement of patents, copyrights, or other intellectual property rights of third parties by or arising from the use of Renesas Electronics products or technical information described in this document. No license, express, implied or otherwise, is granted hereby under any patents, copyrights or other intellectual property rights of Renesas Electronics or others.
3. You should not alter, modify, copy, or otherwise misappropriate any Renesas Electronics product, whether in whole or in part.
4. Descriptions of circuits, software and other related information in this document are provided only to illustrate the operation of semiconductor products and application examples. You are fully responsible for the incorporation of these circuits, software, and information in the design of your equipment. Renesas Electronics assumes no responsibility for any losses incurred by you or third parties arising from the use of these circuits, software, or information.
5. When exporting the products or technology described in this document, you should comply with the applicable export control laws and regulations and follow the procedures required by such laws and regulations. You should not use Renesas Electronics products or the technology described in this document for any purpose relating to military applications or use by the military, including but not limited to the development of weapons of mass destruction. Renesas Electronics products and technology may not be used for or incorporated into any products or systems whose manufacture, use, or sale is prohibited under any applicable domestic or foreign laws or regulations.
6. Renesas Electronics has used reasonable care in preparing the information included in this document, but Renesas Electronics does not warrant that such information is error free. Renesas Electronics assumes no liability whatsoever for any damages incurred by you resulting from errors in or omissions from the information included herein.
7. Renesas Electronics products are classified according to the following three quality grades: “Standard”, “High Quality”, and “Specific”. The recommended applications for each Renesas Electronics product depends on the product’s quality grade, as indicated below. You must check the quality grade of each Renesas Electronics product before using it in a particular application. You may not use any Renesas Electronics product for any application categorized as “Specific” without the prior written consent of Renesas Electronics. Further, you may not use any Renesas Electronics product for any application for which it is not intended without the prior written consent of Renesas Electronics. Renesas Electronics shall not be in any way liable for any damages or losses incurred by you or third parties arising from the use of any Renesas Electronics product for an application categorized as “Specific” or for which the product is not intended where you have failed to obtain the prior written consent of Renesas Electronics. The quality grade of each Renesas Electronics product is “Standard” unless otherwise expressly specified in a Renesas Electronics data sheets or data books, etc.
 - “Standard”: Computers; office equipment; communications equipment; test and measurement equipment; audio and visual equipment; home electronic appliances; machine tools; personal electronic equipment; and industrial robots.
 - “High Quality”: Transportation equipment (automobiles, trains, ships, etc.); traffic control systems; anti-disaster systems; anti-crime systems; safety equipment; and medical equipment not specifically designed for life support.
 - “Specific”: Aircraft; aerospace equipment; submersible repeaters; nuclear reactor control systems; medical equipment or systems for life support (e.g. artificial life support devices or systems), surgical implantations, or healthcare intervention (e.g. excision, etc.), and any other applications or purposes that pose a direct threat to human life.
8. You should use the Renesas Electronics products described in this document within the range specified by Renesas Electronics, especially with respect to the maximum rating, operating supply voltage range, movement power voltage range, heat radiation characteristics, installation and other product characteristics. Renesas Electronics shall have no liability for malfunctions or damages arising out of the use of Renesas Electronics products beyond such specified ranges.
9. Although Renesas Electronics endeavors to improve the quality and reliability of its products, semiconductor products have specific characteristics such as the occurrence of failure at a certain rate and malfunctions under certain use conditions. Further, Renesas Electronics products are not subject to radiation resistance design. Please be sure to implement safety measures to guard them against the possibility of physical injury, and injury or damage caused by fire in the event of the failure of a Renesas Electronics product, such as safety design for hardware and software including but not limited to redundancy, fire control and malfunction prevention, appropriate treatment for aging degradation or any other appropriate measures. Because the evaluation of microcomputer software alone is very difficult, please evaluate the safety of the final products or system manufactured by you.
10. Please contact a Renesas Electronics sales office for details as to environmental matters such as the environmental compatibility of each Renesas Electronics product. Please use Renesas Electronics products in compliance with all applicable laws and regulations that regulate the inclusion or use of controlled substances, including without limitation, the EU RoHS Directive. Renesas Electronics assumes no liability for damages or losses occurring as a result of your noncompliance with applicable laws and regulations.
11. This document may not be reproduced or duplicated, in any form, in whole or in part, without prior written consent of Renesas Electronics.
12. Please contact a Renesas Electronics sales office if you have any questions regarding the information contained in this document or Renesas Electronics products, or if you have any other inquiries.

(Note 1) “Renesas Electronics” as used in this document means Renesas Electronics Corporation and also includes its majority-owned subsidiaries.

(Note 2) “Renesas Electronics product(s)” means any product developed or manufactured by or for Renesas Electronics.

1. Overview

The M16C/30P Group of single-chip microcomputers is built using the high-performance silicon gate CMOS process using a M16C/60 Series CPU core and is packaged in a 100-pin plastic molded QFP.

These single-chip microcomputers operate using sophisticated instructions featuring a high level of instruction efficiency. With 1 Mbyte of address space, they are capable of executing instructions at high speed. In addition, these microcomputers contain a multiplier and DMAC which combined with fast instruction processing capability, make it suitable for control of various OA, communication, and industrial equipment which requires high-speed arithmetic/logic operations.

1.1 Applications

Audio, cameras, TV, home appliance, office/communications/portable/industrial equipment, etc.

1.2 Performance Outline

Table 1.1 lists Performance Outline of M16C/30P Group.

Table 1.1 Performance Outline of M16C/30P Group

Item		Performance
CPU	Number of Basic Instructions	91 instructions
	Minimum Instruction Execution Time	62.5ns(f(XIN)=16MHz, VCC1=VCC2=3.0 to 5.5V, no wait) 100ns(f(XIN)=10MHz, VCC1=VCC2=2.7 to 5.5V, no wait)
	Operation Mode	Single-chip, memory expansion and microprocessor mode
	Memory Space	1 Mbyte
	Memory Capacity	See Table 1.2 Product List
Peripheral Function	Port	Input/Output : 87 pins, Input : 1 pin
	Multifunction Timer	Timer A : 16 bits x 3 channels, Timer B : 16 bits x 3 channels
	Serial Interface	1 channels Clock synchronous, UART, I ² CBus ⁽¹⁾ , IEBus ⁽²⁾ 2 channels Clock synchronous, UART, I ² CBus ⁽¹⁾
	A/D Converter	10-bit A/D converter: 1 circuit, 18 channels
	DMAC	2 channels
	CRC Calculation Circuit	CCITT-CRC
	Watchdog Timer	15 bits x 1 channel (with prescaler)
	Interrupt	Internal: 20 sources, External: 7 sources, Software: 4 sources, Priority level: 7 levels
	Clock Generating Circuit	2 circuits Main clock generation circuit (*), Subclock generation circuit (*), (*)Equipped with a built-in feedback resistor.
Electric Characteristics	Supply Voltage	VCC1=VCC2=3.0 to 5.5 V (f(XIN)=16MHz) VCC1=VCC2=2.7 to 5.5 V (f(XIN)=10MHz, no wait)
	Power Consumption	10 mA (VCC1=VCC2=5V, f(XIN)=16MHz) 8 mA (VCC1=VCC2=3V, f(XIN)=10MHz) 1.8 μ A (VCC1=VCC2=3V, f(XCIN)=32kHz, wait mode) 0.7 μ A (VCC1=VCC2=3V, stop mode)
One time flash version	Program Supply Voltage	3.3 \pm 0.3 V or 5.0 \pm 0.5 V
Flash memory version	Program/Erase Supply Voltage	3.3 \pm 0.3 V or 5.0 \pm 0.5 V
	Program and Erase Endurance	100 times (all area)
Operating Ambient Temperature		-20 to 85°C, -40 to 85°C
Package		100-pin plastic mold QFP, LQFP

NOTES:

1. I²C bus is a registered trademark of Koninklijke Philips Electronics N. V.
2. IEBus is a registered trademark of NEC Electronics Corporation.
3. Use the M16C/30P on VCC1 = VCC2.

1.3 Block Diagram

Figure 1.1 is a M16C/30P Group Block Diagram.

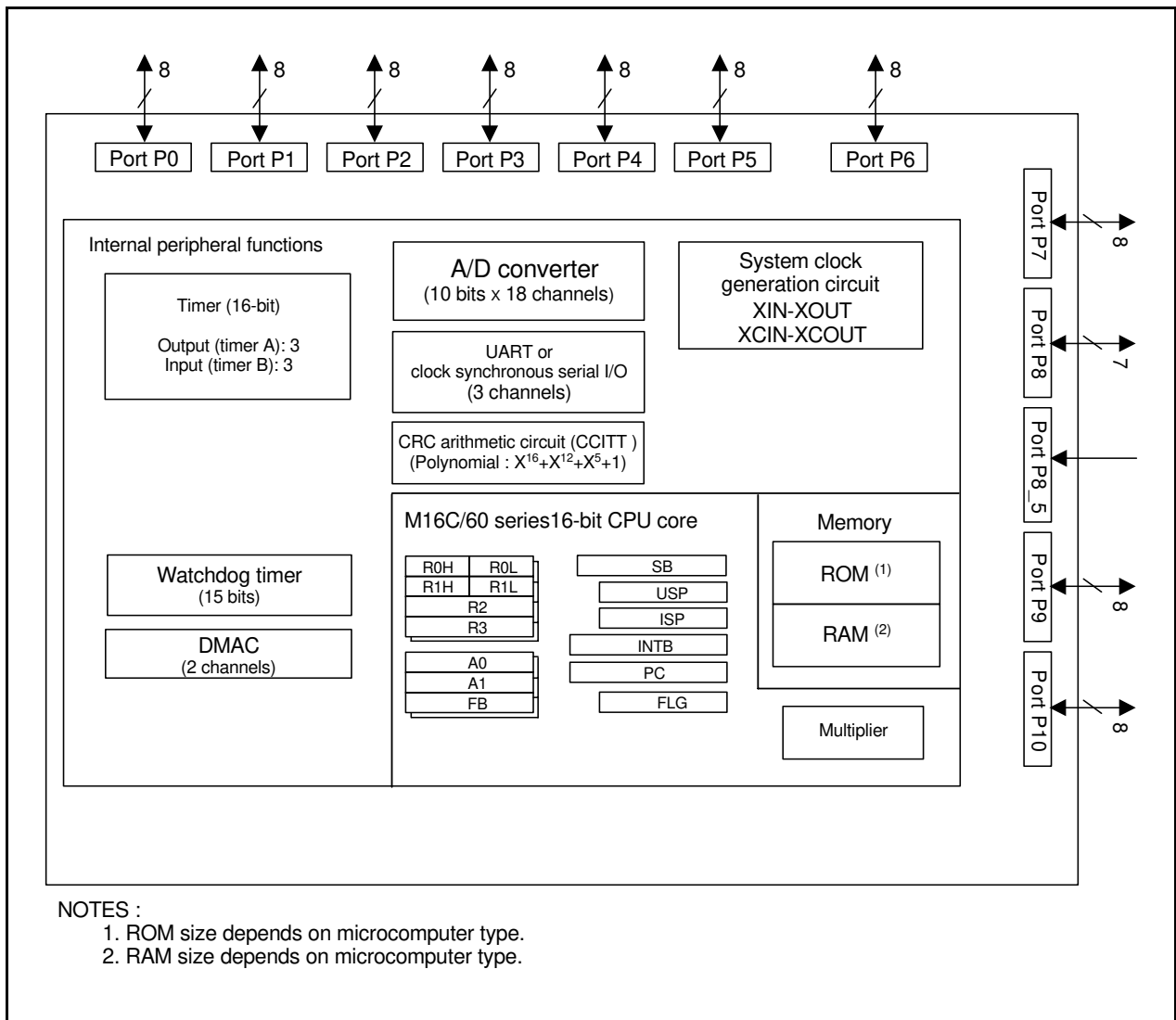

Figure 1.1 M16C/30P Group Block Diagram

1.4 Product List

Table 1.2 lists the M16C/30P group products and Figure 1.2 shows the Part No., Memory Size, and Package. Table 1.4 lists Product Code of MASK ROM version for M16C/30P. Figure 1.3 shows the Marking Diagram of Mask ROM Version for M16C/30P (Top View). Table 1.5 lists Product Code of One Time Flash version, Flash Memory version, and ROM-less version for M16C/30P. Figure 1.4 shows the Marking Diagram of One Time Flash version, Flash Memory version, and ROM-less Version for M16C/30P (Top View). Please specify the marking for M16C30P (MASK ROM version) when placing an order for ROM.

Table 1.2 Product List (1)

As of March 2007

Part No.	ROM Capacity	RAM Capacity	package code ⁽¹⁾	Remarks
M30302MAP-XXXFP	96 Kbytes	5 Kbytes	PRQP0100JB-A	Mask ROM version
M30302MAP-XXXGP			PLQP0100KB-A	
M30302MCP-XXXFP	128 Kbytes		PRQP0100JB-A	
M30302MCP-XXXGP			PLQP0100KB-A	
M30302MDP-XXXFP	160 Kbytes	6 Kbytes	PRQP0100JB-A	
M30302MDP-XXXGP			PLQP0100KB-A	
M30302MEP-XXXFP	192 Kbytes		PRQP0100JB-A	
M30302MEP-XXXGP			PLQP0100KB-A	
M30302GAPFP	96 Kbytes	5 Kbytes	PRQP0100JB-A	One Time Flash version (blank product)
M30302GAPGP (D)			PLQP0100KB-A	
M30302GCPFP	128 Kbytes		PRQP0100JB-A	
M30302GCPGP (D)			PLQP0100KB-A	
M30302GDPFP	160 Kbytes	6 Kbytes	PRQP0100JB-A	
M30302GDPPGP (D)			PLQP0100KB-A	
M30304GDPFP (D)		12 Kbytes	PRQP0100JB-A	
M30304GDPPGP (D)			PLQP0100KB-A	
M30302GEPFP	192 Kbytes	6 Kbytes	PRQP0100JB-A	
M30302GEPGP (D)			PLQP0100KB-A	
M30304GEPFP (D)		12 Kbytes	PRQP0100JB-A	
M30304GEPGP (D)			PLQP0100KB-A	
M30302GGPFP (D)	256 Kbytes	12 Kbytes	PRQP0100JB-A	
M30302GGPPGP (D)			PLQP0100KB-A	
M30302GAP-XXXFP	96 Kbytes	5 Kbytes	PRQP0100JB-A	One Time Flash version (factory programmed product)
M30302GAPvGP (D)			PLQP0100KB-A	
M30302GCP-XXXFP	128 Kbytes		PRQP0100JB-A	
M30302GCP-XXXGP (D)			PLQP0100KB-A	
M30302GDP-XXXFP	160 Kbytes	6 Kbytes	PRQP0100JB-A	
M30302GDP-XXXGP (D)			PLQP0100KB-A	
M30304GDP-XXXFP (D)		12 Kbytes	PRQP0100JB-A	
M30304GDP-XXXGP (D)			PLQP0100KB-A	
M30302GEP-XXXFP	192 Kbytes	6 Kbytes	PRQP0100JB-A	
M30302GEP-XXXGP (D)			PLQP0100KB-A	
M30304GEP-XXXFP (D)		12 Kbytes	PRQP0100JB-A	
M30304GEP-XXXGP (D)			PLQP0100KB-A	
M30302GGP-XXXFP (D)	256 Kbytes	12 Kbytes	PRQP0100JB-A	
M30302GGP-XXXGP (D)			PLQP0100KB-A	

(D): Under development

(P): Under planning

NOTES:

- Previous package codes are as follows.
PRQP0100JB-A : 100P6S-A,
PLQP0100KB-A : 100P6Q-A
- Block A (4-Kbytes space) is available in flash memory version.

Table 1.3 Product List (2)

As of March 2007

Part No.	ROM Capacity	RAM Capacity	package code ⁽¹⁾	Remarks
M30302FAPFP	96 K + 4 Kbytes	5 Kbytes	PRQP0100JB-A	Flash memory version ⁽²⁾
M30302FAPGP			PLQP0100KB-A	
M30302FCPFP	128 K + 4 Kbytes		PRQP0100JB-A	
M30302FCPGP			PLQP0100KB-A	
M30302FEPFP	192 K + 4 Kbytes	6 Kbytes	PRQP0100JB-A	ROM-less version
M30302FEPGP			PLQP0100KB-A	
M30302SPFP	-	6 Kbytes	PRQP0100JB-A	
M30302SPGP			PLQP0100KB-A	

(D): Under development

(P): Under planning

NOTES:

1. Previous package codes are as follows.
 PRQP0100JB-A : 100P6S-A,
 PLQP0100KB-A : 100P6Q-A
2. Block A (4-Kbytes space) is available in flash memory version.

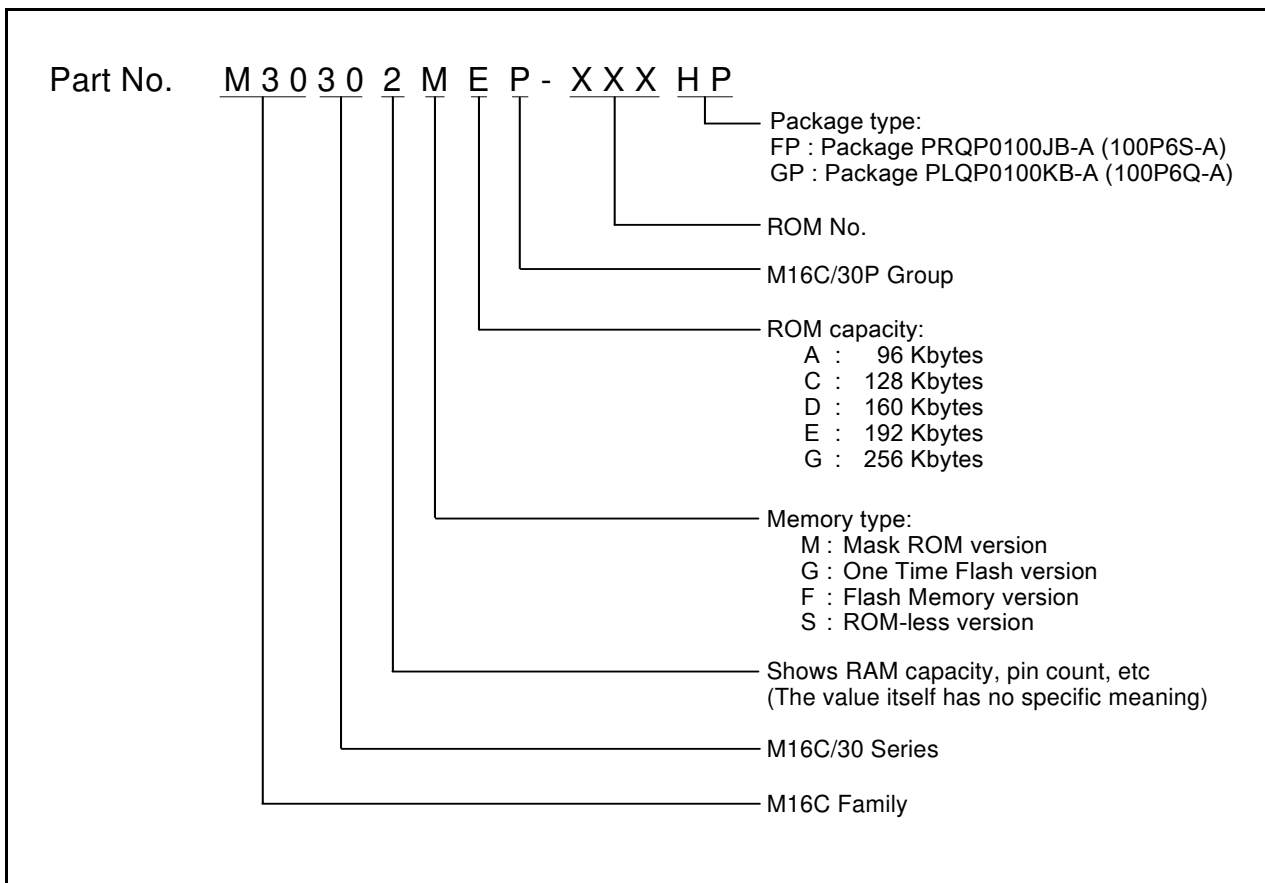

Figure 1.2 Part No., Memory Size, and Package

Table 1.4 Product Code of MASK ROM version for M16C/30P

Product Code	Package	Operating Ambient Temperature
U1	Lead-free	-20°C to 85°C
U4		-40°C to 85°C

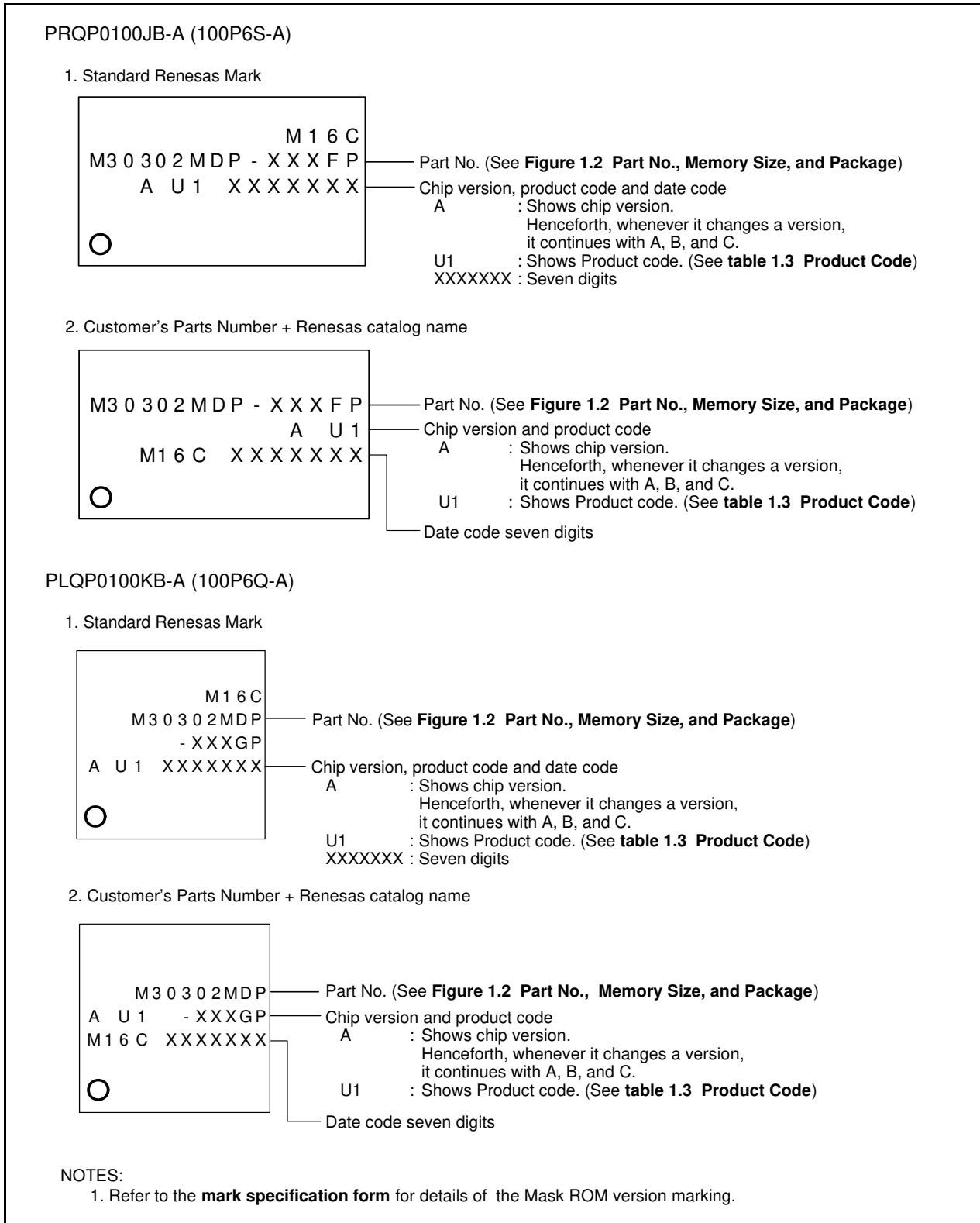

Figure 1.3 Marking Diagram of Mask ROM Version for M16C/30P (Top View)

Table 1.5 Product Code of One Time Flash version, Flash Memory version, and ROM-less version for M16C/30P

	Product Code	Package	Internal ROM		Operating Ambient Temperature
			Program and Erase Endurance	Temperature Range	
One Time Flash version	U3	Lead-free	0	0°C to 60°C	-40°C to 85°C
	U5				-20°C to 85°C
Flash Memory version	U3	Lead-free	100	0°C to 60°C	-40°C to 85°C
	U5				-20°C to 85°C
ROM-less version	U3	Lead-free	-	-	-40°C to 85°C
	U5				-20°C to 85°C

NOTES: The one time flash version can be written once only.

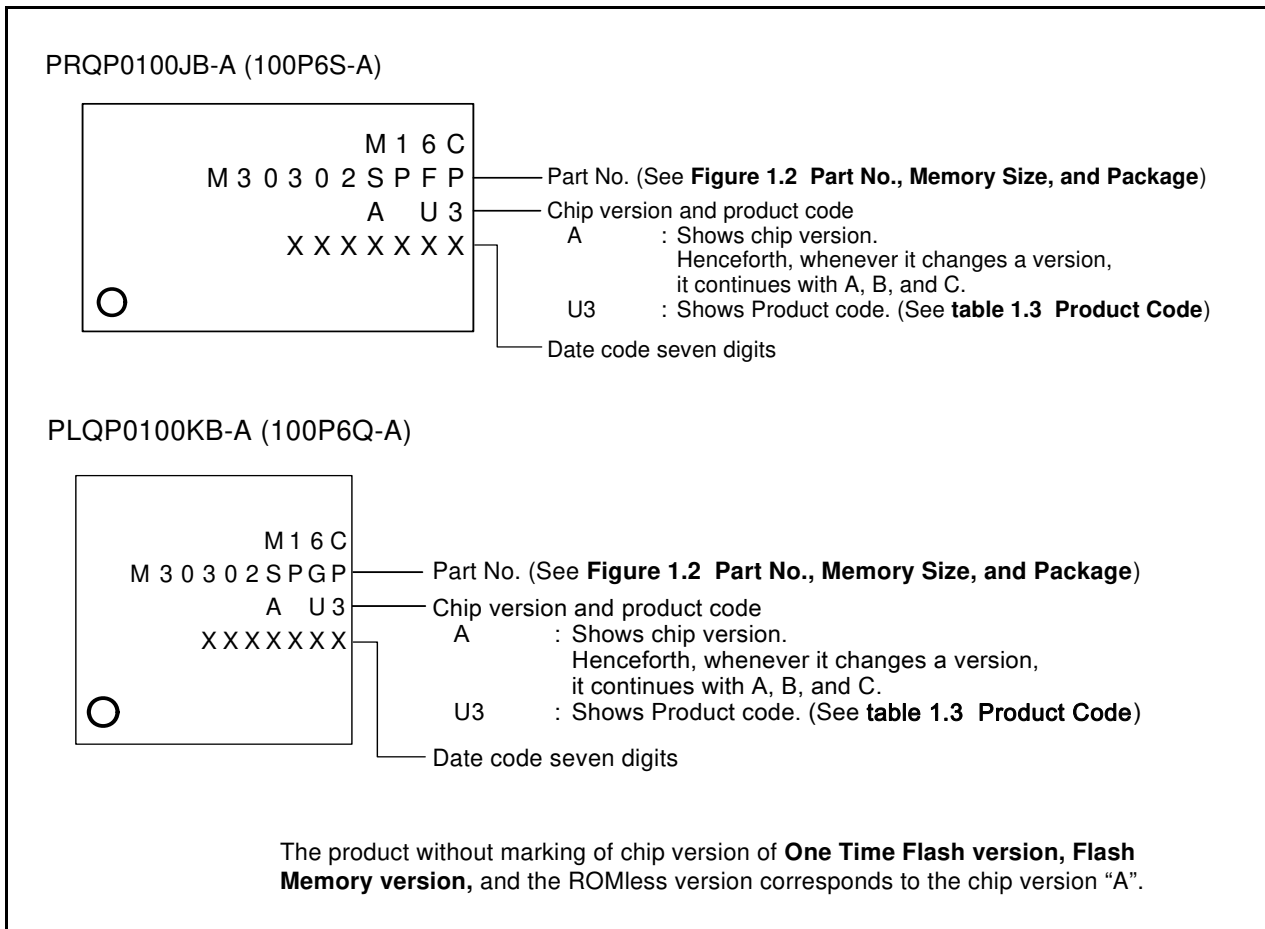

Figure 1.4 Marking Diagram of One Time Flash version, Flash Memory version, and ROM-less Version for M16C/30P (Top View)

1.5 Pin Configuration

Figures 1.5 to 1.6 show the pin configurations (top view).

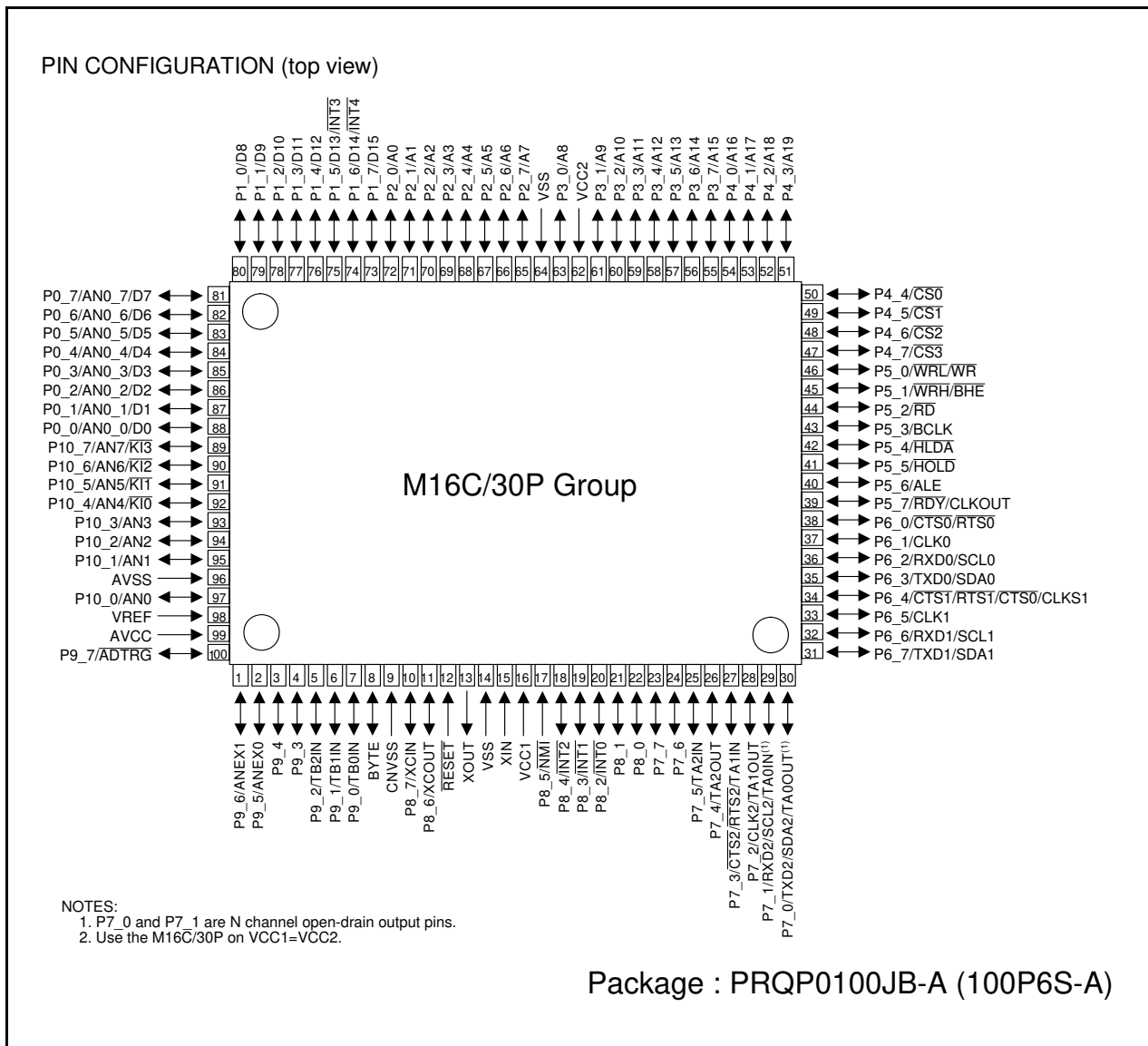

Figure 1.5 Pin Configuration (Top View)

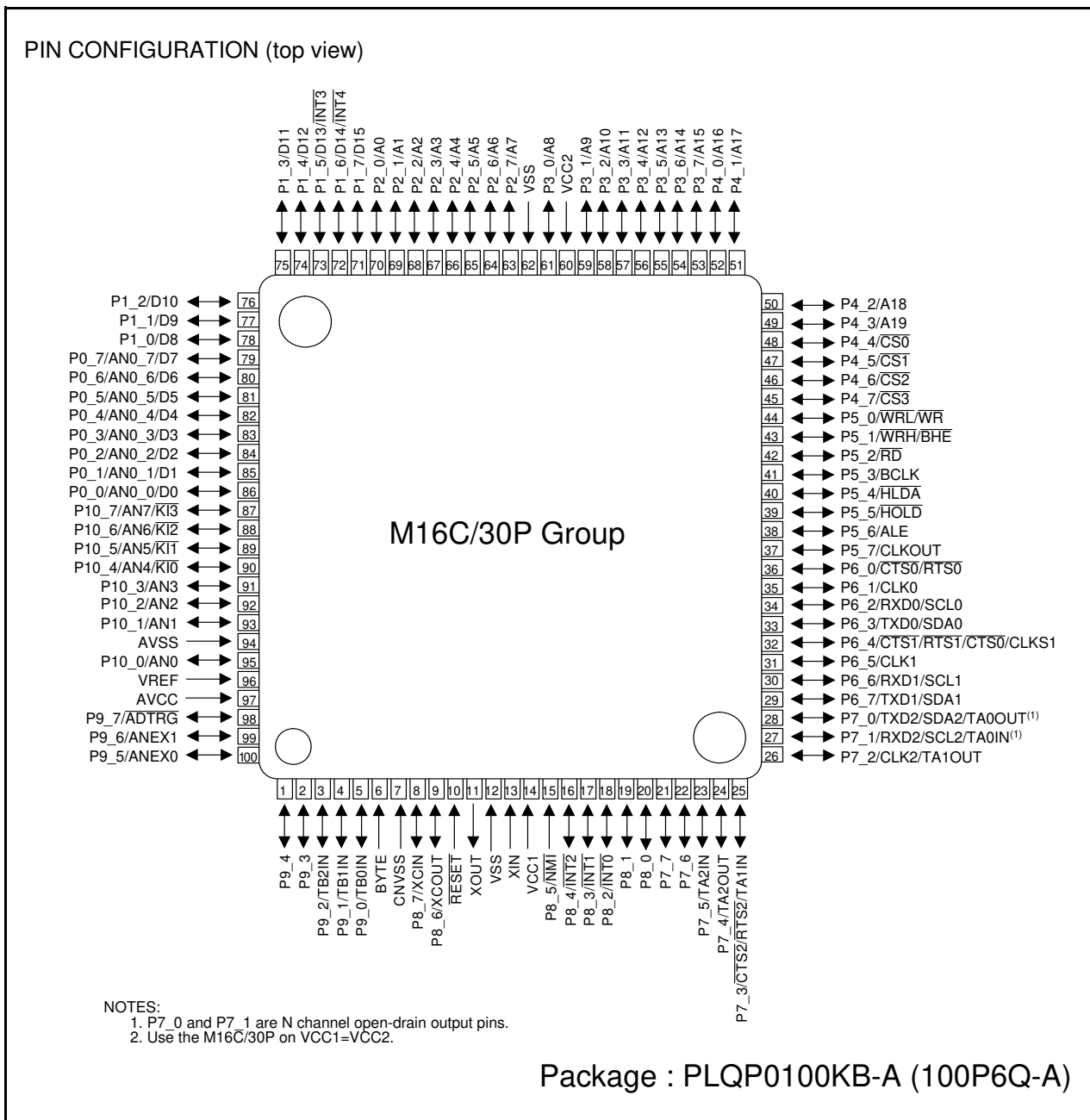

Figure 1.6 Pin Configuration (Top View)

Table 1.6 Pin Characteristics (1)

Pin No.		Control Pin	Port	Interrupt Pin	Timer Pin	UART Pin	Analog Pin	Bus Control Pin
FP	GP							
1	99		P9_6				ANEX1	
2	100		P9_5				ANEX0	
3	1		P9_4					
4	2		P9_3					
5	3		P9_2		TB2IN			
6	4		P9_1		TB1IN			
7	5		P9_0		TB0IN			
8	6	BYTE						
9	7	CNVSS						
10	8	XCIN	P8_7					
11	9	XCOUT	P8_6					
12	10	RESET						
13	11	XOUT						
14	12	VSS						
15	13	XIN						
16	14	VCC1						
17	15		P8_5	NMI				
18	16		P8_4	INT2				
19	17		P8_3	INT1				
20	18		P8_2	INT0				
21	19		P8_1					
22	20		P8_0					
23	21		P7_7					
24	22		P7_6					
25	23		P7_5		TA2IN			
26	24		P7_4		TA2OUT			
27	25		P7_3		TA1IN	CTS2/RTS2		
28	26		P7_2		TA1OUT	CLK2		
29	27		P7_1		TA0IN	RXD2/SCL2		
30	28		P7_0		TA0OUT	TXD2/SDA2		
31	29		P6_7			TXD1/SDA1		
32	30		P6_6			RXD1/SCL1		
33	31		P6_5			CLK1		
34	32		P6_4			CTS1/RTS1/CTS0/CLKS1		
35	33		P6_3			TXD0/SDA0		
36	34		P6_2			RXD0/SCL0		
37	35		P6_1			CLK0		
38	36		P6_0			CTS0/RTS0		
39	37		P5_7					RDY/CLKOUT
40	38		P5_6					ALE
41	39		P5_5					HOLD
42	40		P5_4					HLDA
43	41		P5_3					BCLK
44	42		P5_2					RD
45	43		P5_1					WRH/BHE
46	44		P5_0					WRL/WR
47	45		P4_7					CS3
48	46		P4_6					CS2
49	47		P4_5					CS1
50	48		P4_4					CS0

Table 1.7 Pin Characteristics (2)

Pin No.		Control Pin	Port	Interrupt Pin	Timer Pin	UART Pin	Analog Pin	Bus Control Pin
FP	GP							
51	49		P4_3					A19
52	50		P4_2					A18
53	51		P4_1					A17
54	52		P4_0					A16
55	53		P3_7					A15
56	54		P3_6					A14
57	55		P3_5					A13
58	56		P3_4					A12
59	57		P3_3					A11
60	58		P3_2					A10
61	59		P3_1					A9
62	60	VCC2						
63	61		P3_0					A8
64	62	VSS						
65	63		P2_7					A7
66	64		P2_6					A6
67	65		P2_5					A5
68	66		P2_4					A4
69	67		P2_3					A3
70	68		P2_2					A2
71	69		P2_1					A1
72	70		P2_0					A0
73	71		P1_7					D15
74	72		P1_6	$\overline{\text{INT4}}$				D14
75	73		P1_5	$\overline{\text{INT3}}$				D13
76	74		P1_4					D12
77	75		P1_3					D11
78	76		P1_2					D10
79	77		P1_1					D9
80	78		P1_0					D8
81	79		P0_7				AN0_7	D7
82	80		P0_6				AN0_6	D6
83	81		P0_5				AN0_5	D5
84	82		P0_4				AN0_4	D4
85	83		P0_3				AN0_3	D3
86	84		P0_2				AN0_2	D2
87	85		P0_1				AN0_1	D1
88	86		P0_0				AN0_0	D0
89	87		P10_7	$\overline{\text{KI3}}$			AN7	
90	88		P10_6	$\overline{\text{KI2}}$			AN6	
91	89		P10_5	$\overline{\text{KI1}}$			AN5	
92	90		P10_4	$\overline{\text{KI0}}$			AN4	
93	91		P10_3				AN3	
94	92		P10_2				AN2	
95	93		P10_1				AN1	
96	94	AVSS						
97	95		P10_0				AN0	
98	96	VREF						
99	97	AVCC						
100	98		P9_7				$\overline{\text{ADTRG}}$	

1.6 Pin Description

Table 1.8 Pin Description (1)

Signal Name	Pin Name	I/O Type	Description
Power supply input	VCC1, VCC2 VSS	I	Apply 2.7 to 5.5 V to the VCC1 and VCC2 pins and 0 V to the Vss pin. The VCC apply condition is that VCC1 = VCC2.
Analog power supply input	AVCC AVSS	I	Applies the power supply for the A/D converter. Connect the AVCC pin to VCC1. Connect the AVSS pin to VSS.
Reset input	$\overline{\text{RESET}}$	I	The microcomputer is in a reset state when applying "L" to the this pin.
CNVSS	CNVSS	I	Switches processor mode. Connect this pin to VSS to when after a reset to start up in single-chip mode. Connect this pin to VCC1 to start up in microprocessor mode.
External data bus width select input	BYTE	I	Switches the data bus in external memory space. The data bus is 16 bits long when the this pin is held "L" and 8 bits long when the this pin is held "H". Set it to either one. Connect this pin to VSS when an single-chip mode.
Bus control pins	D0 to D7	I/O	Inputs and outputs data (D0 to D7) when these pins are set as the separate bus.
	D8 to D15	I/O	Inputs and outputs data (D8 to D15) when external 16-bit data bus is set as the separate bus.
	A0 to A19	O	Output address bits (A0 to A19).
	$\overline{\text{CS0}}$ to $\overline{\text{CS3}}$	O	Output $\overline{\text{CS0}}$ to $\overline{\text{CS3}}$ signals. $\overline{\text{CS0}}$ to $\overline{\text{CS3}}$ are chip-select signals to specify an external space.
	$\overline{\text{WRL}}/\overline{\text{WR}}$ $\overline{\text{WRH}}/\overline{\text{BHE}}$ $\overline{\text{RD}}$	O	Output $\overline{\text{WRL}}$, $\overline{\text{WRH}}$, ($\overline{\text{WR}}$, $\overline{\text{BHE}}$), $\overline{\text{RD}}$ signals. $\overline{\text{WRL}}$ and $\overline{\text{WRH}}$ or $\overline{\text{BHE}}$ and $\overline{\text{WR}}$ can be switched by program. <ul style="list-style-type: none"> • $\overline{\text{WRL}}$, $\overline{\text{WRH}}$ and $\overline{\text{RD}}$ are selected The $\overline{\text{WRL}}$ signal becomes "L" by writing data to an even address in an external memory space. The $\overline{\text{WRH}}$ signal becomes "L" by writing data to an odd address in an external memory space. The $\overline{\text{RD}}$ pin signal becomes "L" by reading data in an external memory space. <ul style="list-style-type: none"> • $\overline{\text{WR}}$, $\overline{\text{BHE}}$ and $\overline{\text{RD}}$ are selected The $\overline{\text{WR}}$ signal becomes "L" by writing data in an external memory space. The $\overline{\text{RD}}$ signal becomes "L" by reading data in an external memory space. The $\overline{\text{BHE}}$ signal becomes "L" by accessing an odd address. Select $\overline{\text{WR}}$, $\overline{\text{BHE}}$ and $\overline{\text{RD}}$ for an external 8-bit data bus.
	ALE	O	ALE is a signal to latch the address.
	HOLD	I	While the HOLD pin is held "L", the microcomputer is placed in a hold state.
	$\overline{\text{HLDA}}$	O	In a hold state, $\overline{\text{HLDA}}$ outputs a "L" signal.
	$\overline{\text{RDY}}$	I	While applying a "L" signal to the $\overline{\text{RDY}}$ pin, the microcomputer is placed in a wait state.

I : Input O : Output I/O : Input and output

Table 1.9 Pin Description (2)

Signal Name	Pin Name	I/O Type	Description
Main clock input	XIN	I	I/O pins for the main clock generation circuit. Connect a ceramic resonator or crystal oscillator between XIN and XOUT. To use the external clock, input the clock from XIN and leave XOUT open.
Main clock output	XOUT	O	
Sub clock input	XCIN	I	I/O pins for a sub clock oscillation circuit. Connect a crystal oscillator between XCIN and XCOU. To use the external clock, input the clock from XCIN and leave XCOU open.
Sub clock output	XCOU	O	
Clock output	CLKOUT	O	The clock of the same cycle as fC, f8, or f32 is outputted.
$\overline{\text{INT}}$ interrupt input	$\overline{\text{INT0}}$ to $\overline{\text{INT4}}$	I	Input pins for the $\overline{\text{INT}}$ interrupt.
$\overline{\text{NMI}}$ interrupt input	$\overline{\text{NMI}}$	I	Input pin for the $\overline{\text{NMI}}$ interrupt.
Key input interrupt input	$\overline{\text{K10}}$ to $\overline{\text{K13}}$	I	Input pins for the key input interrupt.
Timer A	TA0OUT to TA2OUT	I/O	These are timer A0 to timer A2 I/O pins. (however, the output of TA0OUT for the N-channel open drain output.)
	TA0IN to TA2IN	I	These are timer A0 to timer A2 input pins.
Timer B	TB0IN to TB2IN	I	These are timer B0 to timer B2 input pins.
Serial interface	$\overline{\text{CTS0}}$ to $\overline{\text{CTS2}}$	I	These are send control input pins.
	$\overline{\text{RTS0}}$ to $\overline{\text{RTS2}}$	O	These are receive control output pins.
	CLK0 to CLK2	I/O	These are transfer clock I/O pins.
	RXD0 to RXD2	I	These are serial data input pins.
	TXD0 to TXD2	O	These are serial data output pins. (however, TXD2 for the N-channel open drain output.)
	CLKS1	O	This is output pin for transfer clock output from multiple pins function.
I ² C mode	SDA0 to SDA2	I/O	These are serial data I/O pins. (however, SDA2 for the N-channel open drain output.)
	SCL0 to SCL2	I/O	These are transfer clock I/O pins. (however, SCL2 for the N-channel open drain output.)
Reference voltage input	VREF	I	Applies the reference voltage for the A/D converter.
A/D converter	AN0 to AN7, AN0_0 to AN0_7	I	Analog input pins for the A/D converter.
	ADTRG	I	This is an A/D trigger input pin.
	ANEX0	I/O	This is the extended analog input pin for the A/D converter, and is the output in external op-amp connection mode.
	ANEX1	I	This is the extended analog input pin for the A/D converter.
I/O port	P0_0 to P0_7, P1_0 to P1_7, P2_0 to P2_7, P3_0 to P3_7, P4_0 to P4_7, P5_0 to P5_7, P6_0 to P6_7, P7_0 to P7_7, P9_0 to P9_7, P10_0 to P10_7	I/O	8-bit I/O ports in CMOS, having a direction register to select an input or output. Each pin is set as an input port or output port. An input port can be set for a pull-up or for no pull-up in 4-bit unit by program. (however, P7_0 and P7_1 for the N-channel open drain output.)
	P8_0 to P8_4, P8_6, P8_7	I/O	I/O ports having equivalent functions to P0.
Input port	P8_5	I	Input pin for the $\overline{\text{NMI}}$ interrupt. Pin states can be read by the P8_5 bit in the P8 register.

I : Input O : Output I/O : Input and output

2. Central Processing Unit (CPU)

Figure 2.1 shows the CPU registers. The CPU has 13 registers. Of these, R0, R1, R2, R3, A0, A1 and FB comprise a register bank. There are two register banks.

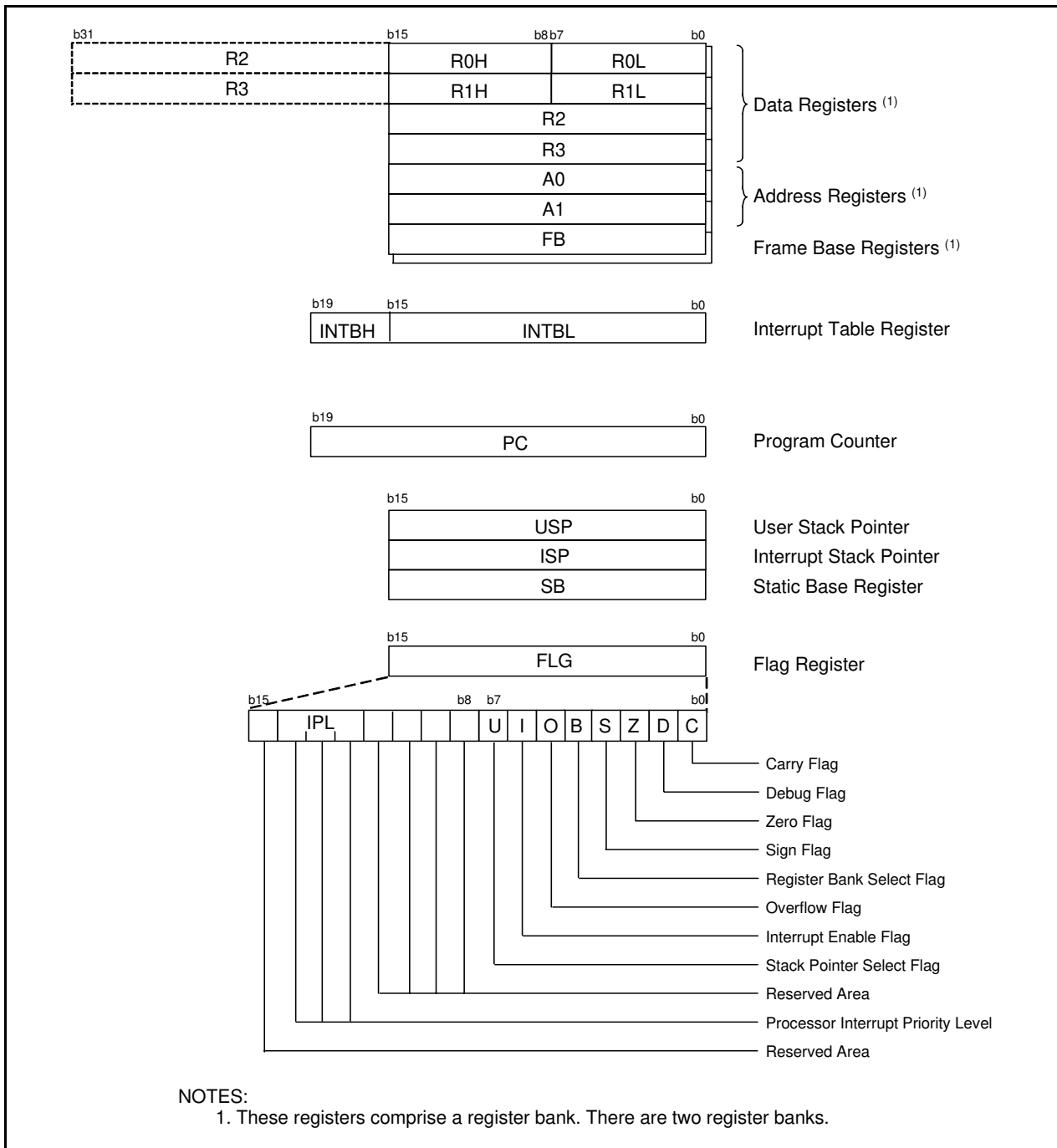

Figure 2.1 Central Processing Unit Register

2.1 Data Registers (R0, R1, R2 and R3)

The R0 register consists of 16 bits, and is used mainly for transfers and arithmetic/logic operations. R1 to R3 are the same as R0.

The R0 register can be separated between high (R0H) and low (R0L) for use as two 8-bit data registers.

R1H and R1L are the same as R0H and R0L. Conversely, R2 and R0 can be combined for use as a 32-bit data register (R2R0). R3R1 is the same as R2R0.

2.2 Address Registers (A0 and A1)

The register A0 consists of 16 bits, and is used for address register indirect addressing and address register relative addressing. They also are used for transfers and logic/logic operations. A1 is the same as A0.

In some instructions, registers A1 and A0 can be combined for use as a 32-bit address register (A1A0).

2.3 Frame Base Register (FB)

FB is configured with 16 bits, and is used for FB relative addressing.

2.4 Interrupt Table Register (INTB)

INTB is configured with 20 bits, indicating the start address of an interrupt vector table.

2.5 Program Counter (PC)

PC is configured with 20 bits, indicating the address of an instruction to be executed.

2.6 User Stack Pointer (USP) and Interrupt Stack Pointer (ISP)

Stack pointer (SP) comes in two types: USP and ISP, each configured with 16 bits.

Your desired type of stack pointer (USP or ISP) can be selected by the U flag of FLG.

2.7 Static Base Register (SB)

SB is configured with 16 bits, and is used for SB relative addressing.

2.8 Flag Register (FLG)

FLG consists of 11 bits, indicating the CPU status.

2.8.1 Carry Flag (C Flag)

This flag retains a carry, borrow, or shift-out bit that has occurred in the arithmetic/logic unit.

2.8.2 Debug Flag (D Flag)

The D flag is used exclusively for debugging purpose. During normal use, it must be set to "0".

2.8.3 Zero Flag (Z Flag)

This flag is set to "1" when an arithmetic operation resulted in 0; otherwise, it is "0".

2.8.4 Sign Flag (S Flag)

This flag is set to "1" when an arithmetic operation resulted in a negative value; otherwise, it is "0".

2.8.5 Register Bank Select Flag (B Flag)

Register bank 0 is selected when this flag is "0"; register bank 1 is selected when this flag is "1".

2.8.6 Overflow Flag (O Flag)

This flag is set to "1" when the operation resulted in an overflow; otherwise, it is "0".

2.8.7 Interrupt Enable Flag (I Flag)

This flag enables a maskable interrupt.

Maskable interrupts are disabled when the I flag is "0", and are enabled when the I flag is "1". The I flag is cleared to "0" when the interrupt request is accepted.

2.8.8 Stack Pointer Select Flag (U Flag)

ISP is selected when the U flag is “0”; USP is selected when the U flag is “1”.

The U flag is cleared to “0” when a hardware interrupt request is accepted or an INT instruction for software interrupt Nos. 0 to 31 is executed.

2.8.9 Processor Interrupt Priority Level (IPL)

IPL is configured with three bits, for specification of up to eight processor interrupt priority levels from level 0 to level 7.

If a requested interrupt has priority greater than IPL, the interrupt is enabled.

2.8.10 Reserved Area

When write to this bit, write “0”. When read, its content is indeterminate.

3. Memory

Figure 3.1 is a Memory Map of the M16C/30P group. The address space extends the 1 Mbyte from address 00000h to FFFFFh.

The internal ROM is allocated in a lower address direction beginning with address FFFFFh. For example, a 64-Kbyte internal ROM is allocated to the addresses from F0000h to FFFFFh.

The fixed interrupt vector table is allocated to the addresses from FFFDCh to FFFFFh. Therefore, store the start address of each interrupt routine here.

The internal RAM is allocated in an upper address direction beginning with address 00400h. For example, a 5-Kbyte internal RAM is allocated to the addresses from 00400h to 017FFh. In addition to storing data, the internal RAM also stores the stack used when calling subroutines and when interrupts are generated. The SFR is allocated to the addresses from 00000h to 003FFh. Peripheral function control registers are located here. Of the SFR, any area which has no functions allocated is reserved for future use and cannot be used by users.

The special page vector table is allocated to the addresses from FFE00h to FFFDBh. This vector is used by the JMPS or JSRS instruction. For details, refer to the **M16C/60 and M16C/20 Series Software Manual**.

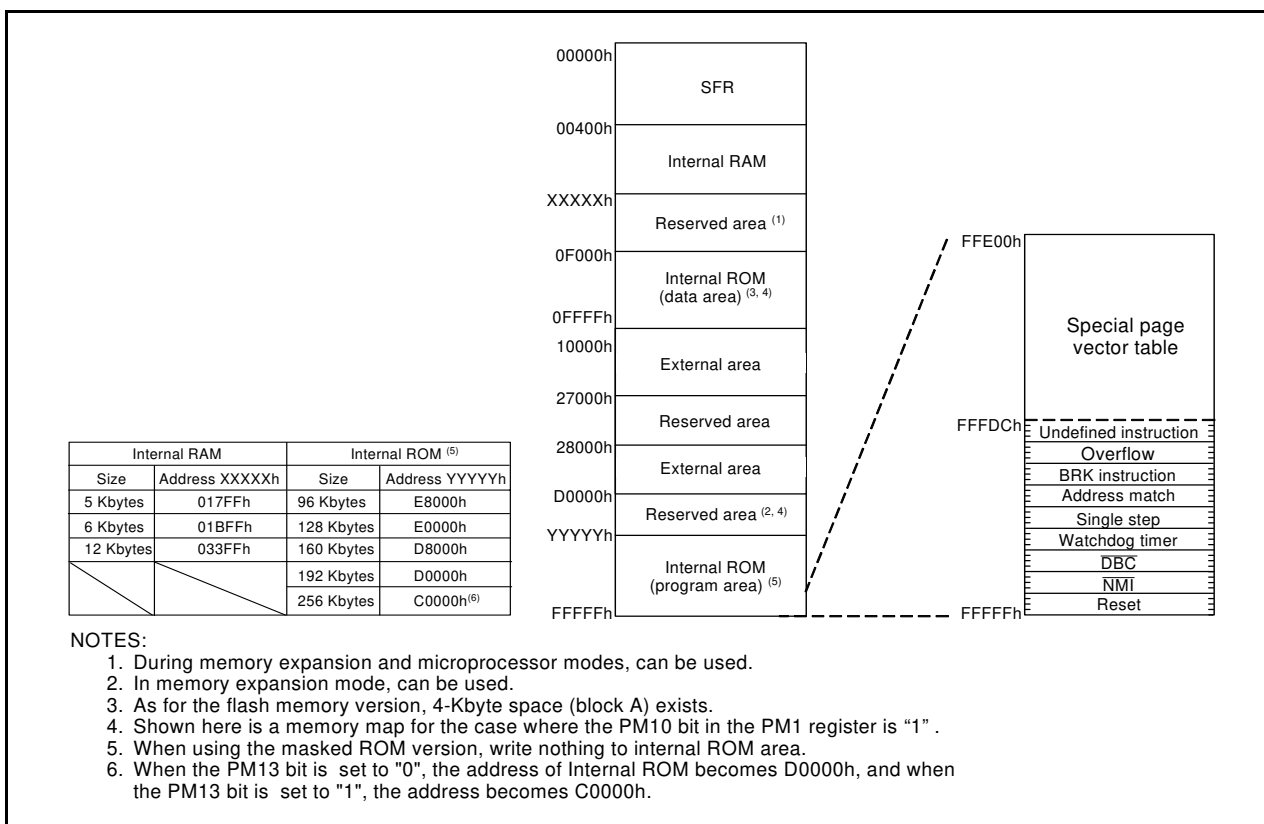

Figure 3.1 Memory Map

4. Special Function Register (SFR)

SFR(Special Function Register) is the control register of peripheral functions. Tables 4.1 to 4.5 list the SFR information.

Table 4.1 SFR Information (1) (1)

Address	Register	Symbol	After Reset
0000h			
0001h			
0002h			
0003h			
0004h	Processor Mode Register 0 ⁽²⁾	PM0	0000000b(CNVSS pin is "L") 00000011b(CNVSS pin is "H")
0005h	Processor Mode Register 1	PM1	00XXX0X0b
0006h	System Clock Control Register 0	CM0	01001000b
0007h	System Clock Control Register 1	CM1	00100000b
0008h	Chip Select Control Register	CSR	00000001b
0009h	Address Match Interrupt Enable Register	AIER	XXXXXXXX00b
000Ah	Protect Register	PRCR	XX000000b
000Bh			
000Ch			
000Dh			
000Eh	Watchdog Timer Start Register	WDTS	XXh
000Fh	Watchdog Timer Control Register	WDC	00XXXXXXb
0010h	Address Match Interrupt Register 0	RMAD0	00h
0011h			00h
0012h			X0h
0013h			
0014h	Address Match Interrupt Register 1	RMAD1	00h
0015h			00h
0016h			X0h
0017h			
0018h			
0019h			
001Ah			
001Bh			
001Ch			
001Dh			
001Eh			
001Fh			
0020h	DMA0 Source Pointer	SAR0	XXh
0021h			XXh
0022h			XXh
0023h			
0024h	DMA0 Destination Pointer	DAR0	XXh
0025h			XXh
0026h			XXh
0027h			
0028h	DMA0 Transfer Counter	TCR0	XXh
0029h			XXh
002Ah			
002Bh			
002Ch	DMA0 Control Register	DM0CON	00000X00b
002Dh			
002Eh			
002Fh			
0030h	DMA1 Source Pointer	SAR1	XXh
0031h			XXh
0032h			XXh
0033h			
0034h	DMA1 Destination Pointer	DAR1	XXh
0035h			XXh
0036h			XXh
0037h			
0038h	DMA1 Transfer Counter	TCR1	XXh
0039h			XXh
003Ah			
003Bh			
003Ch	DMA1 Control Register	DM1CON	00000X00b
003Dh			
003Eh			
003Fh			

NOTES:

1. The blank areas are reserved and cannot be accessed by users.
2. The PM00 and PM01 bits do not change at software reset.

X : Nothing is mapped to this bit

Table 4.2 SFR Information (2) (1)

Address	Register	Symbol	After Reset
0040h			
0041h			
0042h			
0043h			
0044h	INT3 Interrupt Control Register	INT3IC	XX00X000b
0045h			
0046h	UART1 BUS Collision Detection Interrupt Control Register	U1BCNIC	XXXXX000b
0047h	UART0 BUS Collision Detection Interrupt Control Register	U0BCNIC	XXXXX000b
0048h			
0049h	INT4 Interrupt Control Register	INT4IC	XX00X000b
004Ah	UART2 Bus Collision Detection Interrupt Control Register	BCNIC	XXXXX000b
004Bh	DMA0 Interrupt Control Register	DM0IC	XXXXX000b
004Ch	DMA1 Interrupt Control Register	DM1IC	XXXXX000b
004Dh	Key Input Interrupt Control Register	KUPIC	XXXXX000b
004Eh	A/D Conversion Interrupt Control Register	ADIC	XXXXX000b
004Fh	UART2 Transmit Interrupt Control Register	S2TIC	XXXXX000b
0050h	UART2 Receive Interrupt Control Register	S2RIC	XXXXX000b
0051h	UART0 Transmit Interrupt Control Register	S0TIC	XXXXX000b
0052h	UART0 Receive Interrupt Control Register	S0RIC	XXXXX000b
0053h	UART1 Transmit Interrupt Control Register	S1TIC	XXXXX000b
0054h	UART1 Receive Interrupt Control Register	S1RIC	XXXXX000b
0055h	Timer A0 Interrupt Control Register	TA0IC	XXXXX000b
0056h	Timer A1 Interrupt Control Register	TA1IC	XXXXX000b
0057h	Timer A2 Interrupt Control Register	TA2IC	XXXXX000b
0058h			
0059h			
005Ah	Timer B0 Interrupt Control Register	TB0IC	XXXXX000b
005Bh	Timer B1 Interrupt Control Register	TB1IC	XXXXX000b
005Ch	Timer B2 Interrupt Control Register	TB2IC	XXXXX000b
005Dh	INT0 Interrupt Control Register	INT0IC	XX00X000b
005Eh	INT1 Interrupt Control Register	INT1IC	XX00X000b
005Fh	INT2 Interrupt Control Register	INT2IC	XX00X000b
0060h to 01AFh			
01B0h			
01B1h			
01B2h			
01B3h			
01B4h			
01B5h	Flash Memory Control Register 1 ⁽²⁾	FMR1	0X00XX0Xb
01B6h			
01B7h	Flash Memory Control Register 0 ⁽³⁾	FMR0	00000001b
01B8h			
01B9h			
01BAh			
01BBh			
01BCh			
01BDh			
01BEh			
01BFh			
01C0h to 024Fh			
0250h			
0251h			
0252h			
0253h			
0254h			
0255h			
0256h			
0257h			
0258h			
0259h			
025Ah			
025Bh			
025Ch			
025Dh			
025Eh	Peripheral Clock Select Register	PCLKR	00000011b
025Fh			
0260h to 033Fh			

NOTES:

1. The blank areas are reserved and cannot be accessed by users.
2. This register is included in the flash memory version.
3. This register is included in the flash memory version and one time flash version.

X : Nothing is mapped to this bit

Table 4.3 SFR Information (3) (1)

Address	Register	Symbol	After Reset
0340h			
0341h			
0342h			
0343h			
0344h			
0345h			
0346h			
0347h			
0348h			
0349h			
034Ah			
034Bh			
034Ch			
034Dh			
034Eh			
034Fh			
0350h			
0351h			
0352h			
0353h			
0354h			
0355h			
0356h			
0357h			
0358h			
0359h			
035Ah			
035Bh			
035Ch			
035Dh			
035Eh	Interrupt Factor Select Register 2	IFSR2A	00XXXXXXb
035Fh	Interrupt Factor Select Register	IFSR	00h
0360h			
0361h			
0362h			
0363h			
0364h			
0365h			
0366h			
0367h			
0368h			
0369h			
036Ah			
036Bh			
036Ch	UART0 Special Mode Register 4	U0SMR4	00h
036Dh	UART0 Special Mode Register 3	U0SMR3	000X0X0Xb
036Eh	UART0 Special Mode Register 2	U0SMR2	X0000000b
036Fh	UART0 Special Mode Register	U0SMR	X0000000b
0370h	UART1 Special Mode Register 4	U1SMR4	00h
0371h	UART1 Special Mode Register 3	U1SMR3	000X0X0Xb
0372h	UART1 Special Mode Register 2	U1SMR2	X0000000b
0373h	UART1 Special Mode Register	U1SMR	X0000000b
0374h	UART2 Special Mode Register 4	U2SMR4	00h
0375h	UART2 Special Mode Register 3	U2SMR3	000X0X0Xb
0376h	UART2 Special Mode Register 2	U2SMR2	X0000000b
0377h	UART2 Special Mode Register	U2SMR	X0000000b
0378h	UART2 Transmit/Receive Mode Register	U2MR	00h
0379h	UART2 Bit Rate Generator	U2BRG	XXh
037Ah	UART2 Transmit Buffer Register	U2TB	XXh
037Bh			XXh
037Ch	UART2 Transmit/Receive Control Register 0	U2C0	00001000b
037Dh	UART2 Transmit/Receive Control Register 1	U2C1	00000010b
037Eh	UART2 Receive Buffer Register	U2RB	XXh
037Fh			XXh

NOTES:

- The blank areas are reserved and cannot be accessed by users.

X : Nothing is mapped to this bit

Table 4.4 SFR Information (4) (1)

Address	Register	Symbol	After Reset
0380h	Count Start Flag	TABSR	000XX000b
0381h	Clock Prescaler Reset Flag	CPSRF	0XXXXXXXb
0382h	One-Shot Start Flag	ONSF	00XX000b
0383h	Trigger Select Register	TRGSR	XXXX0000b
0384h	Up-Down Flag	UDF	XX0XX000b (2)
0385h			
0386h	Timer A0 Register	TA0	XXh
0387h			XXh
0388h	Timer A1 Register	TA1	XXh
0389h			XXh
038Ah	Timer A2 Register	TA2	XXh
038Bh			XXh
038Ch			
038Dh			
038Eh			
038Fh			
0390h	Timer B0 Register	TB0	XXh
0391h			XXh
0392h	Timer B1 Register	TB1	XXh
0393h			XXh
0394h	Timer B2 Register	TB2	XXh
0395h			XXh
0396h	Timer A0 Mode Register	TA0MR	00h
0397h	Timer A1 Mode Register	TA1MR	00h
0398h	Timer A2 Mode Register	TA2MR	00h
0399h			
039Ah			
039Bh	Timer B0 Mode Register	TB0MR	00XX0000b
039Ch	Timer B1 Mode Register	TB1MR	00XX0000b
039Dh	Timer B2 Mode Register	TB2MR	00XX0000b
039Eh			
039Fh			
03A0h	UART0 Transmit/Receive Mode Register	U0MR	00h
03A1h	UART0 Bit Rate Generator	U0BRG	XXh
03A2h	UART0 Transmit Buffer Register	U0TB	XXh
03A3h			XXh
03A4h	UART0 Transmit/Receive Control Register 0	U0C0	00001000b
03A5h	UART0 Transmit/Receive Control Register 1	U0C1	00000010b
03A6h	UART0 Receive Buffer Register	U0RB	XXh
03A7h			XXh
03A8h	UART1 Transmit/Receive Mode Register	U1MR	00h
03A9h	UART1 Bit Rate Generator	U1BRG	XXh
03AAh	UART1 Transmit Buffer Register	U1TB	XXh
03ABh			XXh
03ACh	UART1 Transmit/Receive Control Register 0	U1C0	00001000b
03ADh	UART1 Transmit/Receive Control Register 1	U1C1	00000010b
03AEh	UART1 Receive Buffer Register	U1RB	XXh
03AFh			XXh
03B0h	UART Transmit/Receive Control Register 2	UCON	X0000000b
03B1h			
03B2h			
03B3h			
03B4h			
03B5h			
03B6h			
03B7h			
03B8h	DMA0 Request Factor Select Register	DM0SL	00h
03B9h			
03BAh	DMA1 Request Factor Select Register	DM1SL	00h
03BBh			
03BCh	CRC Data Register	CRCD	XXh
03BDh			XXh
03BEh	CRC Input Register	CRCIN	XXh
03BFh			

NOTES:

1. The blank areas are reserved and cannot be accessed by users.
2. Bit 5 in the Up-down flag is "0" by reset. However, The values in these bits when read are indeterminate.

X : Nothing is mapped to this bit

Table 4.5 SFR Information (5) (1)

Address	Register	Symbol	After Reset
03C0h 03C1h	A/D Register 0	AD0	XXh XXh
03C2h 03C3h	A/D Register 1	AD1	XXh XXh
03C4h 03C5h	A/D Register 2	AD2	XXh XXh
03C6h 03C7h	A/D Register 3	AD3	XXh XXh
03C8h 03C9h	A/D Register 4	AD4	XXh XXh
03CAh 03CBh	A/D Register 5	AD5	XXh XXh
03CCh 03CDh	A/D Register 6	AD6	XXh XXh
03CEh 03CFh	A/D Register 7	AD7	XXh XXh
03D0h			
03D1h			
03D2h			
03D3h			
03D4h	A/D Control Register 2	ADCON2	XXX000X0b
03D5h			
03D6h	A/D Control Register 0	ADCON0	000X0XXXb
03D7h	A/D Control Register 1	ADCON1	00000XXXb
03D8h			
03D9h			
03DAh			
03DBh			
03DCh			
03DDh			
03DEh			
03DFh			
03E0h	Port P0 Register	P0	XXh
03E1h	Port P1 Register	P1	XXh
03E2h	Port P0 Direction Register	PD0	00h
03E3h	Port P1 Direction Register	PD1	00h
03E4h	Port P2 Register	P2	XXh
03E5h	Port P3 Register	P3	XXh
03E6h	Port P2 Direction Register	PD2	00h
03E7h	Port P3 Direction Register	PD3	00h
03E8h	Port P4 Register	P4	XXh
03E9h	Port P5 Register	P5	XXh
03EAh	Port P4 Direction Register	PD4	00h
03EBh	Port P5 Direction Register	PD5	00h
03ECh	Port P6 Register	P6	XXh
03EDh	Port P7 Register	P7	XXh
03EEh	Port P6 Direction Register	PD6	00h
03EFh	Port P7 Direction Register	PD7	00h
03F0h	Port P8 Register	P8	XXh
03F1h	Port P9 Register	P9	XXh
03F2h	Port P8 Direction Register	PD8	00X00000b
03F3h	Port P9 Direction Register	PD9	00h
03F4h	Port P10 Register	P10	XXh
03F5h			
03F6h	Port P10 Direction Register	PD10	00h
03F7h			
03F8h			
03F9h			
03FAh			
03FBh			
03FCh	Pull-Up Control Register 0	PUR0	00h
03FDh	Pull-Up Control Register 1	PUR1	00000000b (2) 00000010b (2)
03FEh	Pull-Up Control Register 2	PUR2	00h
03FFh	Port Control Register	PCR	00h

NOTES:

- The blank areas are reserved and cannot be accessed by users.
- At hardware reset, the register is as follows:
 - “00000000b” where “L” is inputted to the CNVSS pin
 - “00000010b” where “H” is inputted to the CNVSS pin
At software reset, the register is as follows:
 - “00000000b” where the PM01 to PM00 bits in the PM0 register are “00b” (single-chip mode).
 - “00000010b” where the PM01 to PM00 bits in the PM0 register are “01b” (memory expansion mode) or “11b” (microprocessor mode).

X : Nothing is mapped to this bit

5. Electrical Characteristics

Table 5.1 Absolute Maximum Ratings

Symbol	Parameter		Condition	Rated Value	Unit
V _{CC}	Supply Voltage(V _{CC1} =V _{CC2})		V _{CC1} =V _{CC2} =AV _{CC}	-0.3 to 6.5	V
AV _{CC}	Analog Supply Voltage		V _{CC1} =V _{CC2} =AV _{CC}	-0.3 to 6.5	V
V _i	Input Voltage	$\overline{\text{RESET}}$, CNVSS, BYTE, P0_0 to P0_7, P1_0 to P1_7, P2_0 to P2_7, P3_0 to P3_7, P4_0 to P4_7, P5_0 to P5_7, P6_0 to P6_7, P7_2 to P7_7, P8_0 to P8_7, P9_0 to P9_7, P10_0 to P10_7, VREF, XIN		-0.3 to V _{CC} +0.3	V
		P7_0, P7_1		-0.3 to 6.5	V
V _o	Output Voltage	P0_0 to P0_7, P1_0 to P1_7, P2_0 to P2_7, P3_0 to P3_7, P4_0 to P4_7, P5_0 to P5_7, P6_0 to P6_7, P7_2 to P7_7, P8_0 to P8_4, P8_6, P8_7, P9_0 to P9_7, P10_0 to P10_7, XOUT		-0.3 to V _{CC} +0.3	V
		P7_0, P7_1		-0.3 to 6.5	V
P _d	Power Dissipation		-40°C<T _{opr} ≤85°C	300	mW
T _{opr}	Operating Ambient Temperature	When the Microcomputer is Operating		-20 to 85 / -40 to 85	°C
		One Time Flash Program Erase		0 to 60	
		Flash Program Erase		0 to 60	
T _{stg}	Storage Temperature			-65 to 150	°C