



Chipsmall Limited consists of a professional team with an average of over 10 year of expertise in the distribution of electronic components. Based in Hongkong, we have already established firm and mutual-benefit business relationships with customers from,Europe,America and south Asia,supplying obsolete and hard-to-find components to meet their specific needs.

With the principle of “Quality Parts,Customers Priority,Honest Operation,and Considerate Service”,our business mainly focus on the distribution of electronic components. Line cards we deal with include Microchip,ALPS,ROHM,Xilinx,Pulse,ON,Everlight and Freescale. Main products comprise IC,Modules,Potentiometer,IC Socket,Relay,Connector.Our parts cover such applications as commercial,industrial, and automotives areas.

We are looking forward to setting up business relationship with you and hope to provide you with the best service and solution. Let us make a better world for our industry!



Contact us

Tel: +86-755-8981 8866 Fax: +86-755-8427 6832

Email & Skype: info@chipsmall.com Web: www.chipsmall.com

Address: A1208, Overseas Decoration Building, #122 Zhenhua RD., Futian, Shenzhen, China



Customer Information Sheet

DRAWING No.: M3497-98R

SHEET 2 OF 2

IF IN DOUBT - ASK

©

NOT TO SCALE

THIRD ANGLE PROJECTION

ALL DIMENSIONS IN mm

SPECIFICATION:
MATERIALS:
 INSULATOR = PA9T, HIGH TEMPERATURE THERMOPLASTIC, UL94V-0, BLACK
 CONTACT = PHOSPHOR BRONZE
FINISH:
 CONTACT = 1.00µ - 3.05µ NICKEL ALL OVER, 0.254µ GOLD ON CONTACT AREA, GOLD FLASH ON TAILS.
ELECTRICAL:
 CURRENT RATING = 5A
 VOLTAGE RATING = 1,500V AC/DC
 INSULATION RESISTANCE = 1000MΩ MIN
 CONTACT RESISTANCE = 5mΩ MAX
MECHANICAL:
 INSERTION FORCE = 22.2N MAX (Ø2.03mm PROBE)
 WITHDRAWAL FORCE = 2.2N MIN (Ø2.03mm PROBE)
 DURABILITY = 100 CYCLES
ENVIRONMENTAL:
 OPERATING TEMPERATURE = -40°C TO +105°C
PACKAGING:
 TAPE AND REEL = 1000 PER REEL

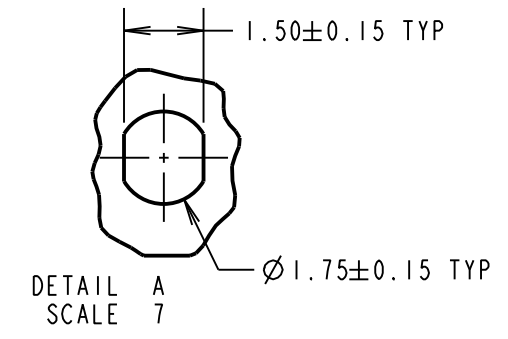
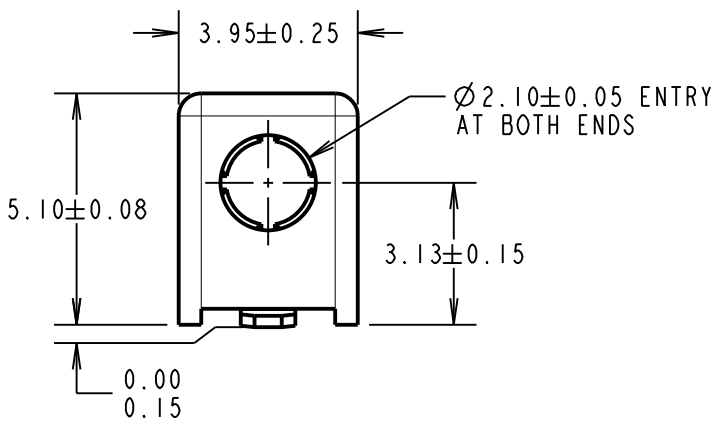
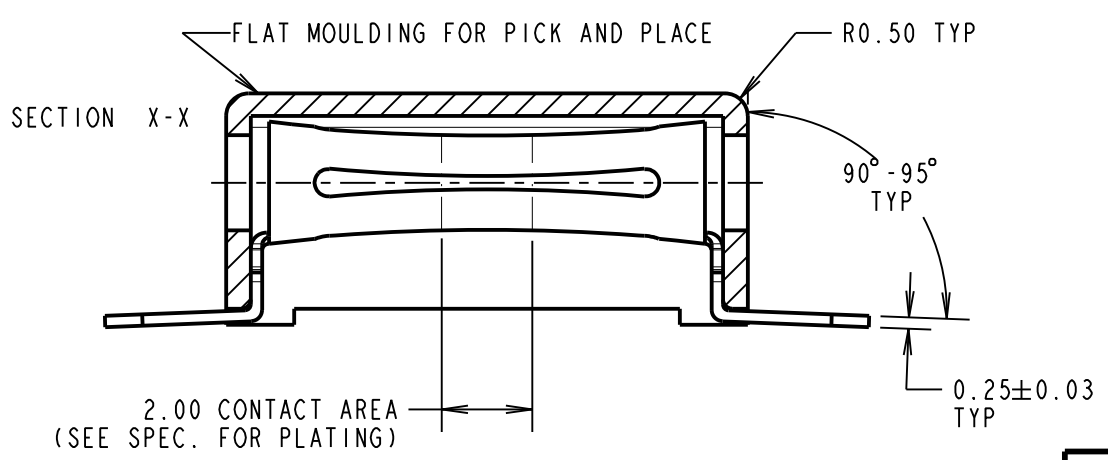
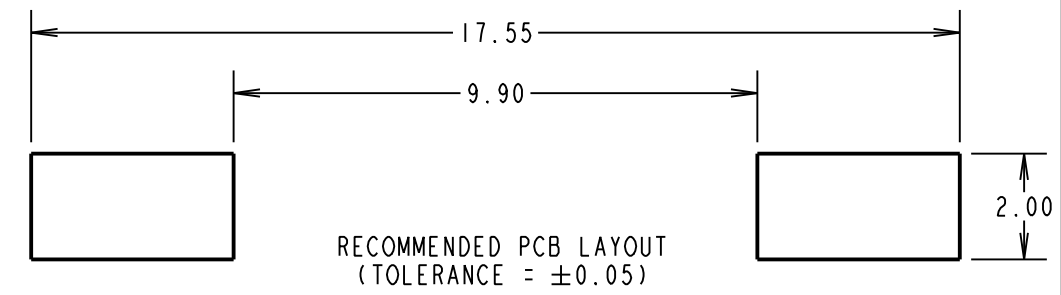
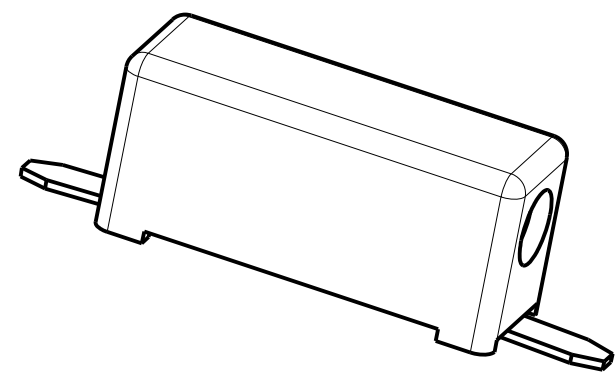
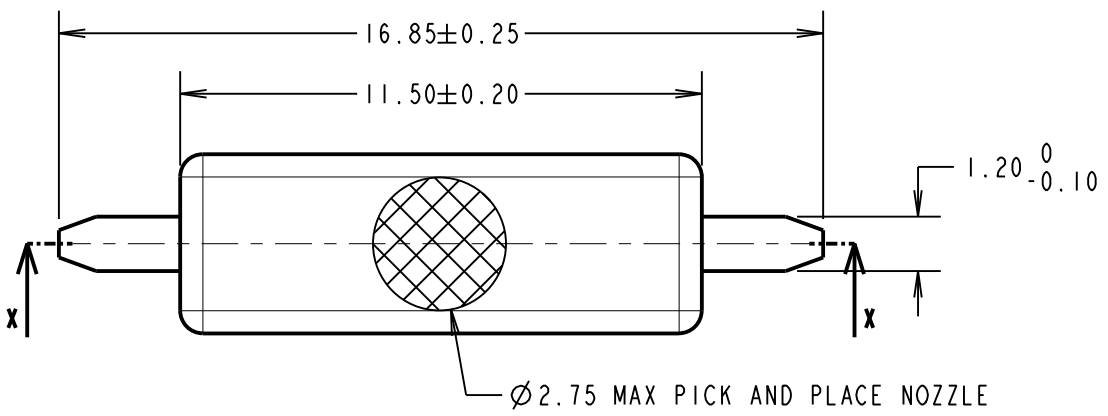
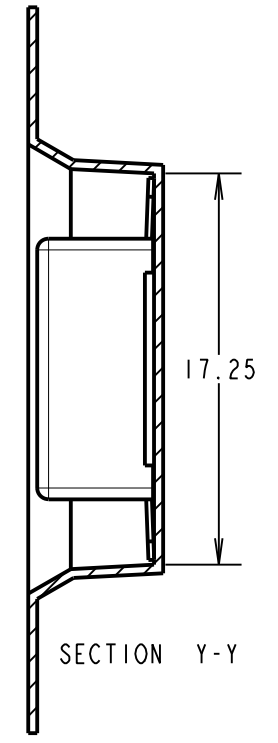
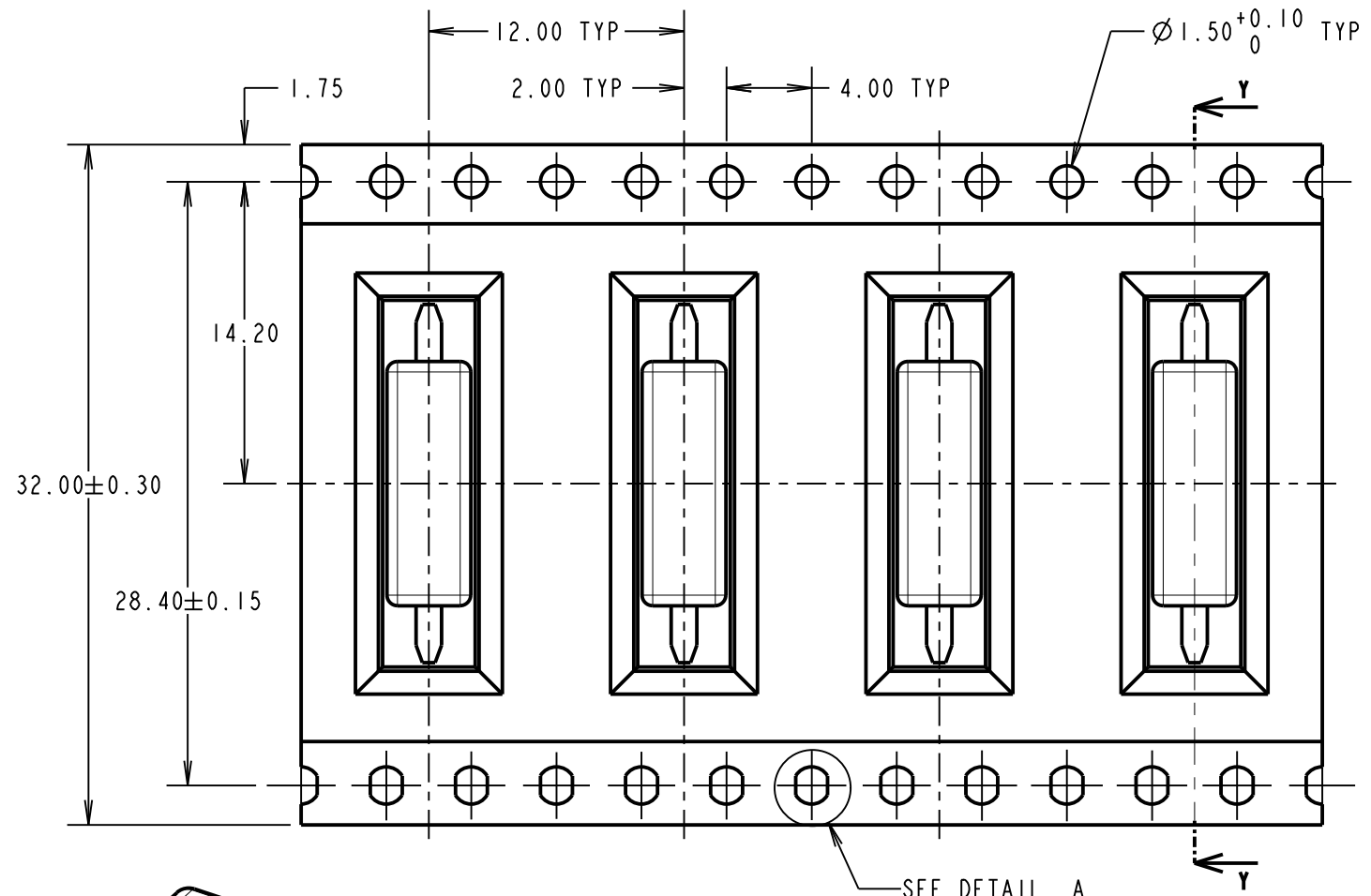

SB	5	10.04.14	12442
NAME	ISS.	DATE	C/NOTE
APPROVED:		S.BENNETT	
CHECKED:		S.FLOWER	
DRAWN:		S.BENNETT	
CUSTOMER REF.:			
ASSEMBLY DRG:			

NOTES:
 1. FOR PRODUCT IN CUT STRIP PACKAGING, SEE DRAWING M3497-98.
 2. RECOMMENDED MATING PROBE: Ø2.01mm MIN TO Ø2.05mm MAX.

<p>www.harwin.com technical@harwin.com</p>	<p>THIS DRAWING AND ANY INFORMATION OR DESCRIPTIVE MATTER SET OUT HEREON ARE CONFIDENTIAL AND COPYRIGHT PROPERTY OF THE HARWIN GROUP AND MUST NOT BE DISCLOSED, LOANED, COPIED OR USED FOR MANUFACTURING, TENDERING OR FOR ANY OTHER PURPOSE WITHOUT THEIR WRITTEN PERMISSION.</p>	<p>TOLERANCES</p> <p>X. = ±1mm X.X = ±0.25mm X.XX = ±0.10mm X.XXX = ±0.01mm</p> <p>ANGLES = ±5° UNLESS STATED</p>	<p>MATERIAL:</p> <p>SEE ABOVE</p>	<p>TITLE:</p> <p>SMT TEST JACK IN TAPE AND REEL</p>
		<p>FINISH: SEE ABOVE</p> <p>S/AREA: mm²</p>	<p>DRAWING NUMBER:</p> <p>M3497-98R</p>	<p>SHT 2 OF 2</p>