



Chipsmall Limited consists of a professional team with an average of over 10 year of expertise in the distribution of electronic components. Based in Hongkong, we have already established firm and mutual-benefit business relationships with customers from,Europe,America and south Asia,supplying obsolete and hard-to-find components to meet their specific needs.

With the principle of “Quality Parts,Customers Priority,Honest Operation,and Considerate Service”,our business mainly focus on the distribution of electronic components. Line cards we deal with include Microchip,ALPS,ROHM,Xilinx,Pulse,ON,Everlight and Freescale. Main products comprise IC,Modules,Potentiometer,IC Socket,Relay,Connector.Our parts cover such applications as commercial,industrial, and automotives areas.

We are looking forward to setting up business relationship with you and hope to provide you with the best service and solution. Let us make a better world for our industry!



Contact us

Tel: +86-755-8981 8866 Fax: +86-755-8427 6832

Email & Skype: info@chipsmall.com Web: www.chipsmall.com

Address: A1208, Overseas Decoration Building, #122 Zhenhua RD., Futian, Shenzhen, China



ZONE	REV	ECO	DESCRIPTION	APPR.	DATE
	E	24392			
	F	24499		PAK	10/8/12
	G	24628		PAK	1/18/13

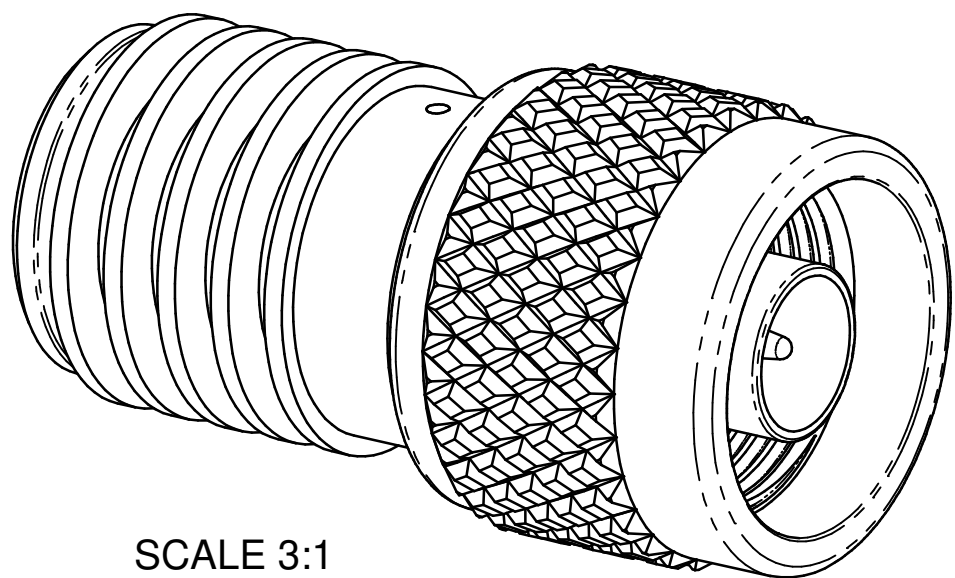

SCALE 3:1

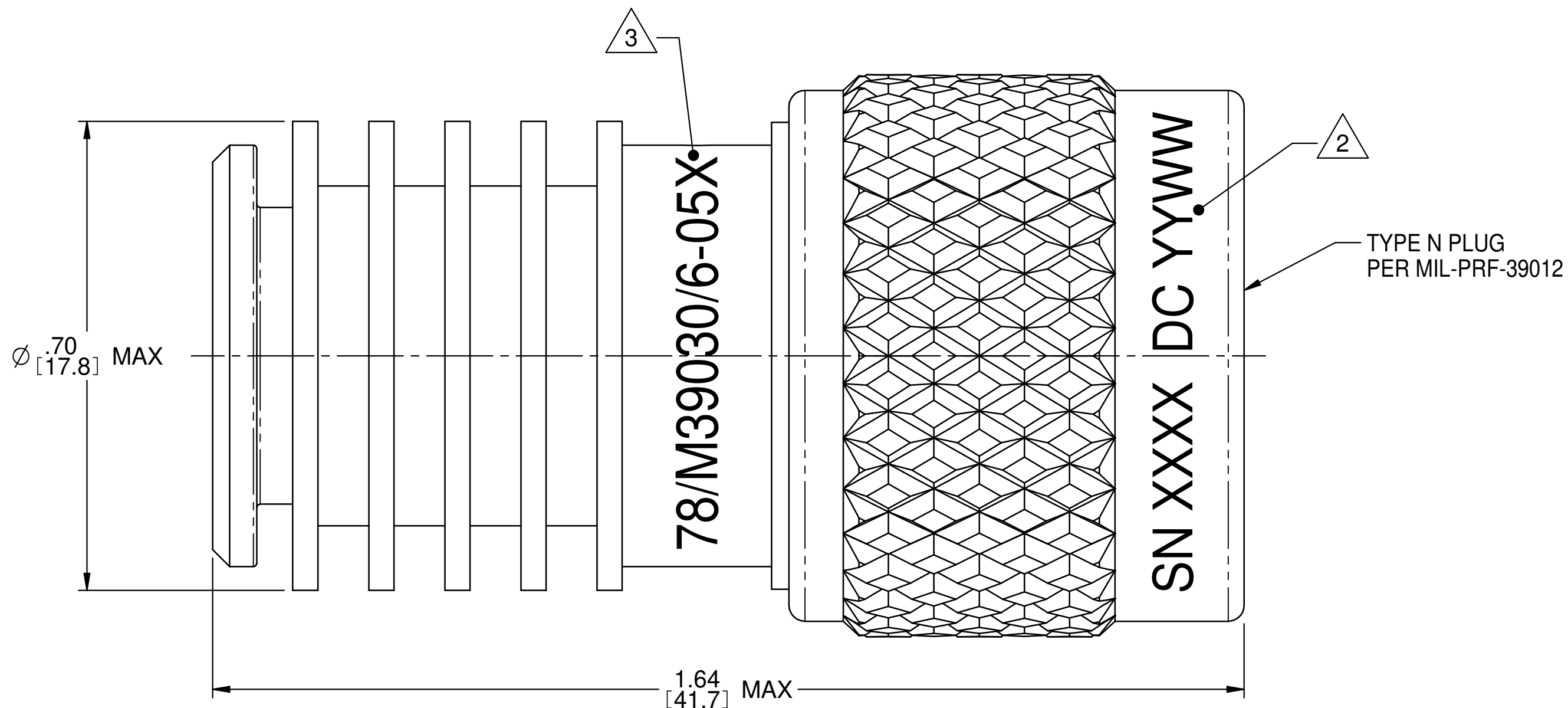

NOTES: UNLESS OTHERWISE SPECIFIED.

1. ELECTRICAL SPECIFICATIONS:
 - 1.1 FREQUENCY RANGE: DC TO 12.4 GHz
 - 1.2 VSWR (MAX): 1.15:1
 - 1.3 POWER HANDLING: 5 WATTS AVERAGE, 2 KILOWATTS PEAK.
 - 1.3.1 AVERAGE INPUT POWER IS DERATED FROM 100% AT +25°C TO 10% AT SPECIFIED MAXIMUM AMBIENT OPERATING TEMPERATURE.
 - 1.4 OPERATING TEMP. RANGE: -55°C TO +125°C
 - 1.5 WEIGHT: 5 OZ MAX.

2. MARK COUPLING NUT AS SHOWN: SN XXXX DC YYWW

3. MARK COUPLING WHERE INDICATED:
34078/M39030/6-05X

X = N FOR NON-SCREENED UNITS
S FOR SCREENED UNITS

4. TESTING: TEST PER ATP-07840-60-02
5. THIS UNIT REQUIRES A DUST CAP, REF CAP-06931-24-04-54.
6. BAG VSWR DATA WITH UNIT.
7. DIMENSIONS IN BRACKETS ARE MILLIMETERS.

	Model No. M39030/6-05(N OR S)		MIDWEST MICROWAVE			
	Cage Code 34078		Title TERMINATION		Material	
<small>This PROPRIETARY Document is property of Emerson Network Power Connectivity Solutions. It is confidential in nature, non-transferable, and issued with the clear understanding that it is not traced or copied without permission and is returnable upon demand.</small>	<small>UNLESS OTHERWISE SPECIFIED</small> UNITS: INCHES .XX ±.02 .XXX ±.005 ANGLES ±1°		Drawing No. M39030/6-05(N OR S)-01		Rev. Finish	
	Drawn by CWW	Date 5/7/13	Approved by PAK	Date 5/8/13	Rev. G	Finish
	Size C		DO NOT SCALE DRAWING		Scale 6:1	Sheet 1 of 1