



Chipsmall Limited consists of a professional team with an average of over 10 year of expertise in the distribution of electronic components. Based in Hongkong, we have already established firm and mutual-benefit business relationships with customers from,Europe,America and south Asia,supplying obsolete and hard-to-find components to meet their specific needs.

With the principle of “Quality Parts,Customers Priority,Honest Operation,and Considerate Service”,our business mainly focus on the distribution of electronic components. Line cards we deal with include Microchip,ALPS,ROHM,Xilinx,Pulse,ON,Everlight and Freescale. Main products comprise IC,Modules,Potentiometer,IC Socket,Relay,Connector.Our parts cover such applications as commercial,industrial, and automotives areas.

We are looking forward to setting up business relationship with you and hope to provide you with the best service and solution. Let us make a better world for our industry!



Contact us

Tel: +86-755-8981 8866 Fax: +86-755-8427 6832

Email & Skype: info@chipsmall.com Web: www.chipsmall.com

Address: A1208, Overseas Decoration Building, #122 Zhenhua RD., Futian, Shenzhen, China



16-Mbit, page-erasable serial flash memory with byte alterability and a 75 MHz SPI bus interface

Features

- SPI bus compatible serial interface
- 75 MHz clock rate (maximum)
- 16-Mbit page-erasable flash memory
- Page of 256 bytes
 - Page write in 11 ms (typical)
 - Page program in 0.8 ms (typical)
 - Page erase in 10 ms (typical)
- Sector erase (512 Kbits)
- Hardware write protection of the bottom sector (64 Kbytes)
- Electronic signature
 - JEDEC standard two-byte signature (4015h)
 - Unique ID code (UID) with 16 bytes read-only, available upon customer
- 2.7 to 3.6 V single supply voltage
- Deep power-down mode 1 μ A (typical)
- More than 100 000 write cycles
- More than 20 years data retention
- Packages
 - ECOPACK® (RoHS compliant)

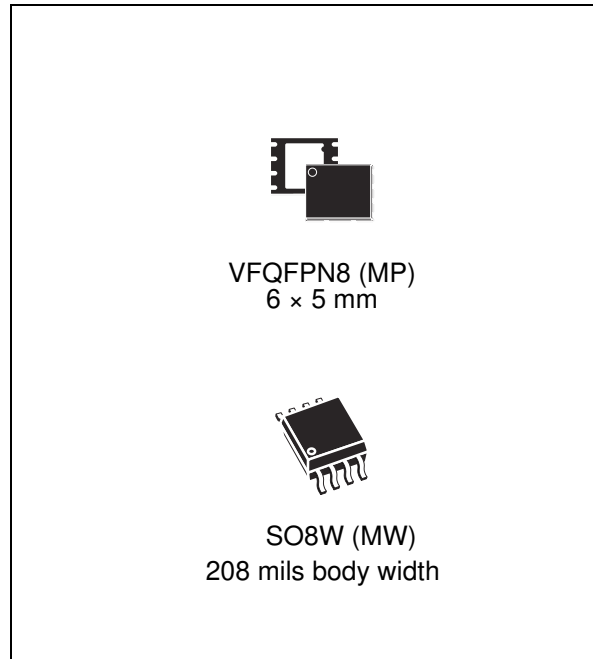

Contents

- 1 Description 6**
- 2 Signal descriptions 8**
 - 2.1 Serial data output (Q) 8
 - 2.2 Serial data input (D) 8
 - 2.3 Serial Clock (C) 8
 - 2.4 Chip Select (\overline{S}) 8
 - 2.5 Reset ($\overline{\text{Reset}}$) 8
 - 2.6 Write Protect (\overline{W}) 8
 - 2.7 V_{CC} supply voltage 9
 - 2.8 V_{SS} ground 9
- 3 SPI modes 10**
- 4 Operating features 12**
 - 4.1 Sharing the overhead of modifying data 12
 - 4.2 An easy way to modify data 12
 - 4.3 A fast way to modify data 13
 - 4.4 Polling during a write, program or erase cycle 13
 - 4.5 Reset 13
 - 4.6 Active power, standby power and deep power-down modes 13
 - 4.7 Status register 14
 - 4.8 Protection modes 14
- 5 Memory organization 15**
- 6 Instructions 17**
 - 6.1 Write enable (WREN) 18
 - 6.2 Write disable (WRDI) 19
 - 6.3 Read identification (RDID) 20
 - 6.4 Read status register (RDSR) 21
 - 6.4.1 WIP bit 21

6.4.2	WEL bit	21
6.5	Read data bytes (READ)	22
6.6	Read data bytes at higher speed (FAST_READ)	23
6.7	Page write (PW)	24
6.8	Page program (PP)	26
6.9	Page erase (PE)	28
6.10	Sector erase (SE)	29
6.11	Deep power-down (DP)	30
6.12	Release from deep power-down (RDP)	31
7	Power-up and power-down	32
8	Initial delivery state	34
9	Maximum ratings	34
10	DC and AC parameters	35
11	Package mechanical	41
12	Ordering information	44
13	Revision history	45

List of tables

Table 1.	Signal names	6
Table 2.	Memory organization	15
Table 3.	Instruction set	17
Table 4.	Read identification (RDID) data-out sequence	20
Table 5.	Status register format	21
Table 6.	Power-up timing and VWI threshold	33
Table 7.	Absolute maximum ratings	34
Table 8.	Operating conditions	35
Table 9.	AC test measurement conditions	35
Table 10.	Capacitance	35
Table 11.	DC characteristics	36
Table 12.	AC characteristics - 50 MHz operation	37
Table 13.	AC characteristics - 75 MHz operation	38
Table 14.	Reset conditions	40
Table 15.	Timings after a Reset Low pulse	40
Table 16.	VFQFPN8 (MLP8) 8-lead very thin fine pitch quad flat package no lead, 6 × 5 mm, package mechanical data	42
Table 17.	SO8W - 8 lead plastic small outline, 208 mils body width, package mechanical data	43
Table 18.	Ordering information scheme	44
Table 19.	Document revision history	45

List of figures

Figure 1.	Logic diagram	6
Figure 2.	MLP and SO8 connections	7
Figure 3.	Bus master and memory devices on the SPI bus	10
Figure 4.	SPI modes supported	11
Figure 5.	Block diagram	16
Figure 6.	Write enable (WREN) instruction sequence	18
Figure 7.	Write disable (WRDI) instruction sequence	19
Figure 8.	Read identification (RDID) instruction sequence and data-out sequence	20
Figure 9.	Read status register (RDSR) instruction sequence and data-out sequence	21
Figure 10.	Read data bytes (READ) instruction sequence and data-out sequence	22
Figure 11.	Read data bytes at higher speed (FAST_READ) instruction sequence and data-out sequence	23
Figure 12.	Page write (PW) instruction sequence	25
Figure 13.	Page program (PP) instruction sequence	27
Figure 14.	Page erase (PE) instruction sequence	28
Figure 15.	Sector erase (SE) instruction sequence	29
Figure 16.	Deep power-down (DP) instruction sequence	30
Figure 17.	Release from deep power-down (RDP) instruction sequence	31
Figure 18.	Power-up timing	33
Figure 19.	AC test measurement I/O waveform	35
Figure 20.	Serial input timing	39
Figure 21.	Write protect setup and hold timing	39
Figure 22.	Output timing	39
Figure 23.	Reset AC waveforms	40
Figure 24.	VFQFPN8 (MLP8) 8-lead very thin fine pitch quad flat package no lead, 6 × 5 mm, package outline	41
Figure 25.	SO8W - 8 lead plastic small outline, 208 mils body width, package outline	43

1 Description

The M45PE16 is a 16-Mbit (2 Mbit x8 bit) serial paged flash memory accessed by a high speed SPI-compatible bus.

The memory can be written or programmed 1 to 256 bytes at a time, using the page write or page program instruction. The page write instruction consists of an integrated page erase cycle followed by a page program cycle.

The memory is organized as 32 sectors, each containing 256 pages. Each page is 256-byte wide. Thus, the whole memory can be viewed as consisting of 8192 pages, or 2,097,152 bytes.

The memory can be erased a page at a time, using the page erase instruction, or a sector at a time, using the sector erase instruction.

Important note

Delivery of parts operating with a maximum clock rate of 75 MHz starts from week 8 of 2008.

Figure 1. Logic diagram

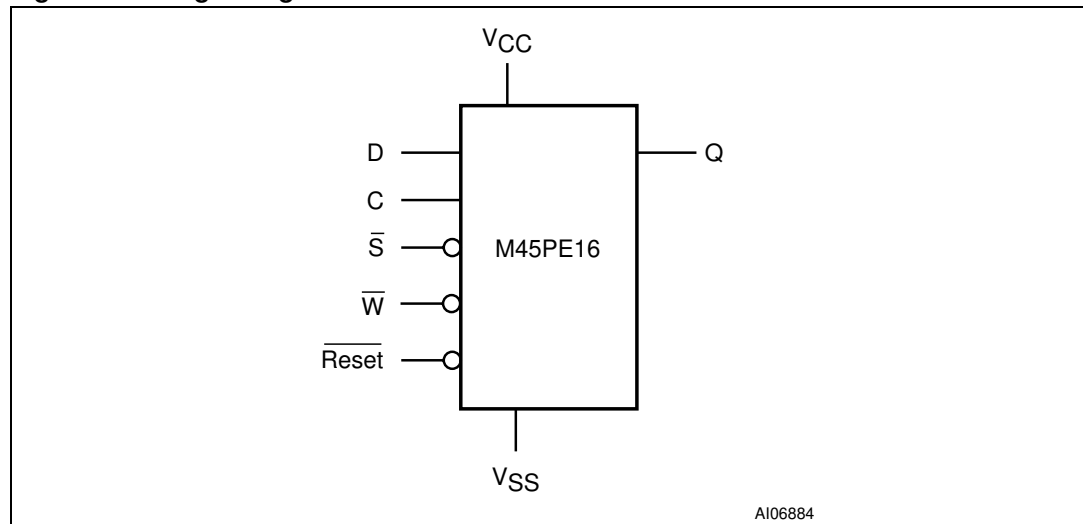
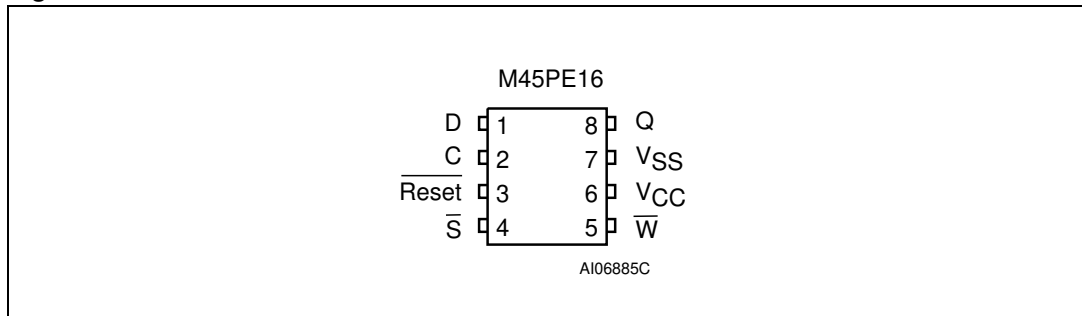

Table 1. Signal names

Signal name	Function	Direction
C	Serial Clock	Input
D	Serial data input	Input
Q	Serial data output	Output
\bar{S}	Chip Select	Input
\bar{W}	Write Protect	Input
$\overline{\text{Reset}}$	Reset	Input
V_{CC}	Supply voltage	
V_{SS}	Ground	

Figure 2. MLP and SO8 connections



1. There is an exposed central pad on the underside of the VFQFPN package. This is pulled, internally, to V_{SS}, and must not be allowed to be connected to any other voltage or signal line on the PCB.
2. See [Package mechanical](#) section for package dimensions, and how to identify pin-1.

2 Signal descriptions

2.1 Serial data output (Q)

This output signal is used to transfer data serially out of the device. Data is shifted out on the falling edge of Serial Clock (C).

2.2 Serial data input (D)

This input signal is used to transfer data serially into the device. It receives instructions, addresses, and the data to be programmed. Values are latched on the rising edge of Serial Clock (C).

2.3 Serial Clock (C)

This input signal provides the timing of the serial interface. Instructions, addresses, or data present at serial data input (D) are latched on the rising edge of Serial Clock (C). Data on serial data output (Q) changes after the falling edge of Serial Clock (C).

2.4 Chip Select (\overline{S})

When this input signal is High, the device is deselected and serial data output (Q) is at high impedance. Unless an internal read, program, erase or write cycle is in progress, the device will be in the standby mode (this is not the deep power-down mode). Driving Chip Select (\overline{S}) Low enables the device, placing it in the active power mode.

After power-up, a falling edge on Chip Select (\overline{S}) is required prior to the start of any instruction.

2.5 Reset ($\overline{\text{Reset}}$)

The Reset ($\overline{\text{Reset}}$) input provides a hardware reset for the memory.

When Reset ($\overline{\text{Reset}}$) is driven High, the memory is in the normal operating mode. When Reset ($\overline{\text{Reset}}$) is driven Low, the device enters the reset mode. In this mode, the output Q is high impedance.

If an internal operation (write, erase or program cycle) is in progress when Reset ($\overline{\text{Reset}}$) is driven Low, the device enters the reset mode and any on-going write, program or erase cycle is aborted. The addressed data may be lost.

2.6 Write Protect (\overline{W})

This input signal puts the device in the hardware protected mode, when Write Protect (\overline{W}) is connected to V_{SS} , causing the first 256 pages of memory to become read-only by protecting them from write, program and erase operations. When Write Protect (\overline{W}) is connected to V_{CC} , the first 256 pages of memory behave like the other pages of memory.

2.7 V_{CC} supply voltage

V_{CC} is the supply voltage.

2.8 V_{SS} ground

V_{SS} is the reference for the V_{CC} supply voltage.

3 SPI modes

These devices can be driven by a microcontroller with its SPI peripheral running in either of the two following modes:

- CPOL=0, CPHA=0
- CPOL=1, CPHA=1

For these two modes, input data is latched in on the rising edge of Serial Clock (C), and output data is available from the falling edge of Serial Clock (C).

The difference between the two modes, as shown in *Figure 4*, is the clock polarity when the bus master is in Stand-by mode and not transferring data:

- C remains at 0 for (CPOL=0, CPHA=0)
- C remains at 1 for (CPOL=1, CPHA=1)

Figure 3. Bus master and memory devices on the SPI bus

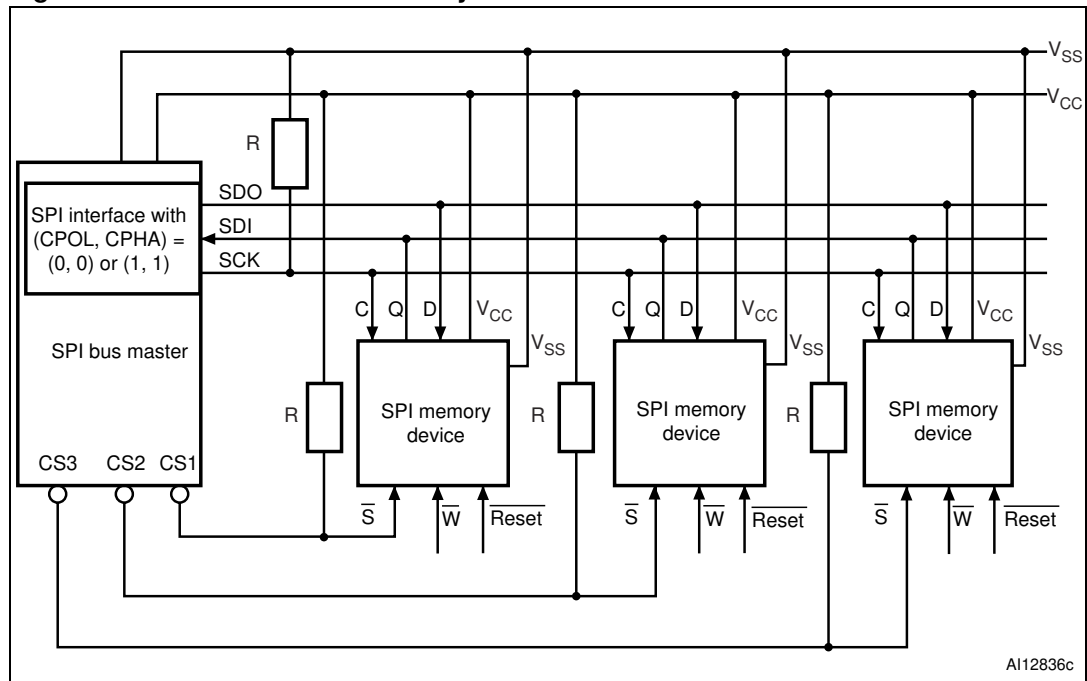

1. The Write Protect (\overline{W}) signal should be driven, High or Low as appropriate.

Figure 3 shows an example of three devices connected to an MCU, on an SPI bus. Only one device is selected at a time, so only one device drives the serial data output (Q) line at a time, the other devices are high impedance. Resistors R (represented in *Figure 3*) ensure that the M45PE16 is not selected if the bus master leaves the \overline{S} line in the high impedance state. As the bus master may enter a state where all inputs/outputs are in high impedance at the same time (for example, when the bus master is reset), the clock line (C) must be connected to an external pull-down resistor so that, when all inputs/outputs become high impedance, the \overline{S} line is pulled High while the C line is pulled Low (thus ensuring that \overline{S} and C do not become High at the same time, and so, that the t_{SHCH} requirement is met). The typical value of R is 100 k Ω , assuming that the time constant $R \cdot C_p$ (C_p = parasitic capacitance of the bus line) is shorter than the time during which the bus master leaves the SPI bus in high impedance.

Example: $C_p = 50 \text{ pF}$, that is $R \cdot C_p = 5 \text{ }\mu\text{s}$ \Leftrightarrow the application must ensure that the bus master never leaves the SPI bus in the high impedance state for a time period shorter than $5 \text{ }\mu\text{s}$.

Figure 4. SPI modes supported

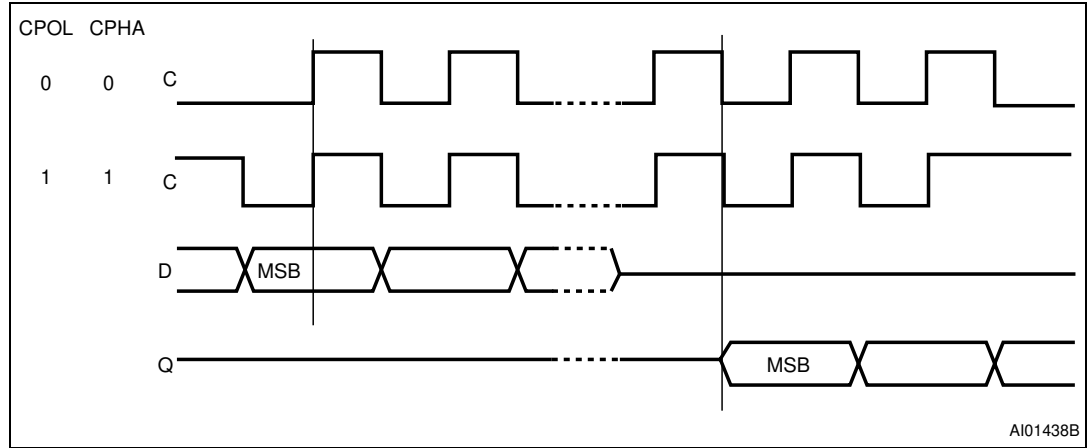

4 Operating features

4.1 Sharing the overhead of modifying data

To write or program one (or more) data bytes, two instructions are required: write enable (WREN), which is one byte, and a page write (PW) or page program (PP) sequence, which consists of four bytes plus data. This is followed by the internal cycle (of duration t_{PW} or t_{PP}).

To share this overhead, the page write (PW) or page program (PP) instruction allows up to 256 bytes to be programmed (changing bits from '1' to '0') or written (changing bits to '0' or '1') at a time, provided that they lie in consecutive addresses on the same page of memory.

4.2 An easy way to modify data

The page write (PW) instruction provides a convenient way of modifying data (up to 256 contiguous bytes at a time), and simply requires the start address, and the new data in the instruction sequence.

The page write (PW) instruction is entered by driving Chip Select (\overline{CS}) Low, and then transmitting the instruction byte, three address bytes (A23-A0) and at least one data byte, and then driving Chip Select (\overline{CS}) High. While Chip Select (\overline{CS}) is being held Low, the data bytes are written to the data buffer, starting at the address given in the third address byte (A7-A0). When Chip Select (\overline{CS}) is driven High, the write cycle starts. The remaining, unchanged, bytes of the data buffer are automatically loaded with the values of the corresponding bytes of the addressed memory page. The addressed memory page then automatically put into an erase cycle. Finally, the addressed memory page is programmed with the contents of the data buffer.

All of this buffer management is handled internally, and is transparent to the user. The user is given the facility of being able to alter the contents of the memory on a byte-by-byte basis.

For optimized timings, it is recommended to use the page write (PW) instruction to write all consecutive targeted bytes in a single sequence versus using several page write (PW) sequences with each containing only a few bytes (see [Section 6.7: Page write \(PW\)](#), [Table 12: AC characteristics - 50 MHz operation](#), and [Table 13: AC characteristics - 75 MHz operation](#)).

4.3 A fast way to modify data

The page program (PP) instruction provides a fast way of modifying data (up to 256 contiguous bytes at a time), provided that it only involves resetting bits to '0' that had previously been set to '1'.

This might be:

- when the designer is programming the device for the first time
- when the designer knows that the page has already been erased by an earlier page erase (PE) or sector erase (SE) instruction. This is useful, for example, when storing a fast stream of data, having first performed the erase cycle when time was available
- when the designer knows that the only changes involve resetting bits to '0' that are still set to '1'. When this method is possible, it has the additional advantage of minimizing the number of unnecessary erase operations, and the extra stress incurred by each page.

For optimized timings, it is recommended to use the page program (PP) instruction to program all consecutive targeted bytes in a single sequence versus using several page program (PP) sequences with each containing only a few bytes (see [Section 6.8: Page program \(PP\)](#), [Table 12: AC characteristics - 50 MHz operation](#), and [Table 13: AC characteristics - 75 MHz operation](#)).

4.4 Polling during a write, program or erase cycle

A further improvement in the write, program or erase time can be achieved by not waiting for the worst case delay (t_{PW} , t_{PP} , t_{PE} , or t_{SE}). The write in progress (WIP) bit is provided in the status register so that the application program can monitor its value, polling it to establish when the previous cycle is complete.

4.5 Reset

An internal power-on reset circuit helps protect against inadvertent data writes. Additional protection is provided by driving Reset (Reset) Low during the power-on process, and only driving it High when V_{CC} has reached the correct voltage level, $V_{CC}(\min)$.

4.6 Active power, standby power and deep power-down modes

When Chip Select (\overline{S}) is Low, the device is enabled, and in the active power mode.

When Chip Select (\overline{S}) is High, the device is disabled, but could remain in the active power mode until all internal cycles have completed (program, erase, write). The device then goes in to the standby power mode. The device consumption drops to I_{CC1} .

The deep power-down mode is entered when the specific instruction (the enter deep power-down mode (DP) instruction) is executed. The device consumption drops further to I_{CC2} . The device remains in this mode until another specific instruction (the release from deep power-down mode and read electronic signature (RES) instruction) is executed.

All other instructions are ignored while the device is in the deep power-down mode. This can be used as an extra software protection mechanism, when the device is not in active use, to protect the device from inadvertent write, program or erase instructions.

4.7 Status register

The status register contains two status bits that can be read by the read status register (RDSR) instruction. See [Section 6.4: Read status register \(RDSR\)](#) for a detailed description of the status register bits.

4.8 Protection modes

The environments where non-volatile memory devices are used can be very noisy. No SPI device can operate correctly in the presence of excessive noise. To help combat this, the M45PE16 boasts the following data protection mechanisms:

- Power-on reset and an internal timer (t_{PUW}) can provide protection against inadvertent changes while the power supply is outside the operating specification.
- Program, erase and write instructions are checked that they consist of a number of clock pulses that is a multiple of eight, before they are accepted for execution.
- All instructions that modify data must be preceded by a write enable (WREN) instruction to set the write enable latch (WEL) bit. This bit is returned to its reset state by the following events:
 - Power-up
 - Reset ($\overline{\text{Reset}}$) driven Low
 - Write disable (WRDI) instruction completion
 - Page write (PW) instruction completion
 - Page program (PP) instruction completion
 - Page erase (PE) instruction completion
 - Sector erase (SE) instruction completion
- The hardware protected mode is entered when Write Protect ($\overline{\text{WP}}$) is driven Low, causing the first 256 pages of memory to become read-only. When Write Protect ($\overline{\text{WP}}$) is driven High, the first 256 pages of memory behave like the other pages of memory
- In addition to the low power consumption feature, the deep power-down mode offers extra software protection from inadvertent write, program and erase instructions while the device is not in active use.

5 Memory organization

The memory is organized as:

- 8192 pages (256 bytes each).
- 2,097,152 bytes (8 bits each)
- 32 sectors (512 Kbits, 65536 bytes each)

Each page can be individually:

- programmed (bits are programmed from 1 to 0)
- erased (bits are erased from 0 to 1)
- written (bits are changed to either 0 or 1)

The device is page or sector erasable (bits are erased from 0 to 1).

Table 2. Memory organization

Sector	Address range	
31	1F0000h	1FFFFFFh
30	1E0000h	1EFFFFFFh
29	1D0000h	1DFFFFFFh
28	1C0000h	1CFFFFFFh
27	1B0000h	1BFFFFFFh
26	1A0000h	1AFFFFFFh
25	190000h	19FFFFFFh
24	180000h	18FFFFFFh
23	170000h	17FFFFFFh
22	160000h	16FFFFFFh
21	150000h	15FFFFFFh
20	140000h	14FFFFFFh
19	130000h	13FFFFFFh
18	120000h	12FFFFFFh
17	110000h	11FFFFFFh
16	100000h	10FFFFFFh
15	0F0000h	0FFFFFFh
14	0E0000h	0EFFFFFFh
13	0D0000h	0DFFFFFFh
12	0C0000h	0CFFFFFFh
11	0B0000h	0BFFFFFFh
10	0A0000h	0AFFFFFFh
9	090000h	09FFFFFFh
8	080000h	08FFFFFFh

Table 2. Memory organization (continued)

Sector	Address range	
7	070000h	07FFFFh
6	060000h	06FFFFh
5	050000h	05FFFFh
4	040000h	04FFFFh
3	030000h	03FFFFh
2	020000h	02FFFFh
1	010000h	01FFFFh
0	000000h	00FFFFh

Figure 5. Block diagram

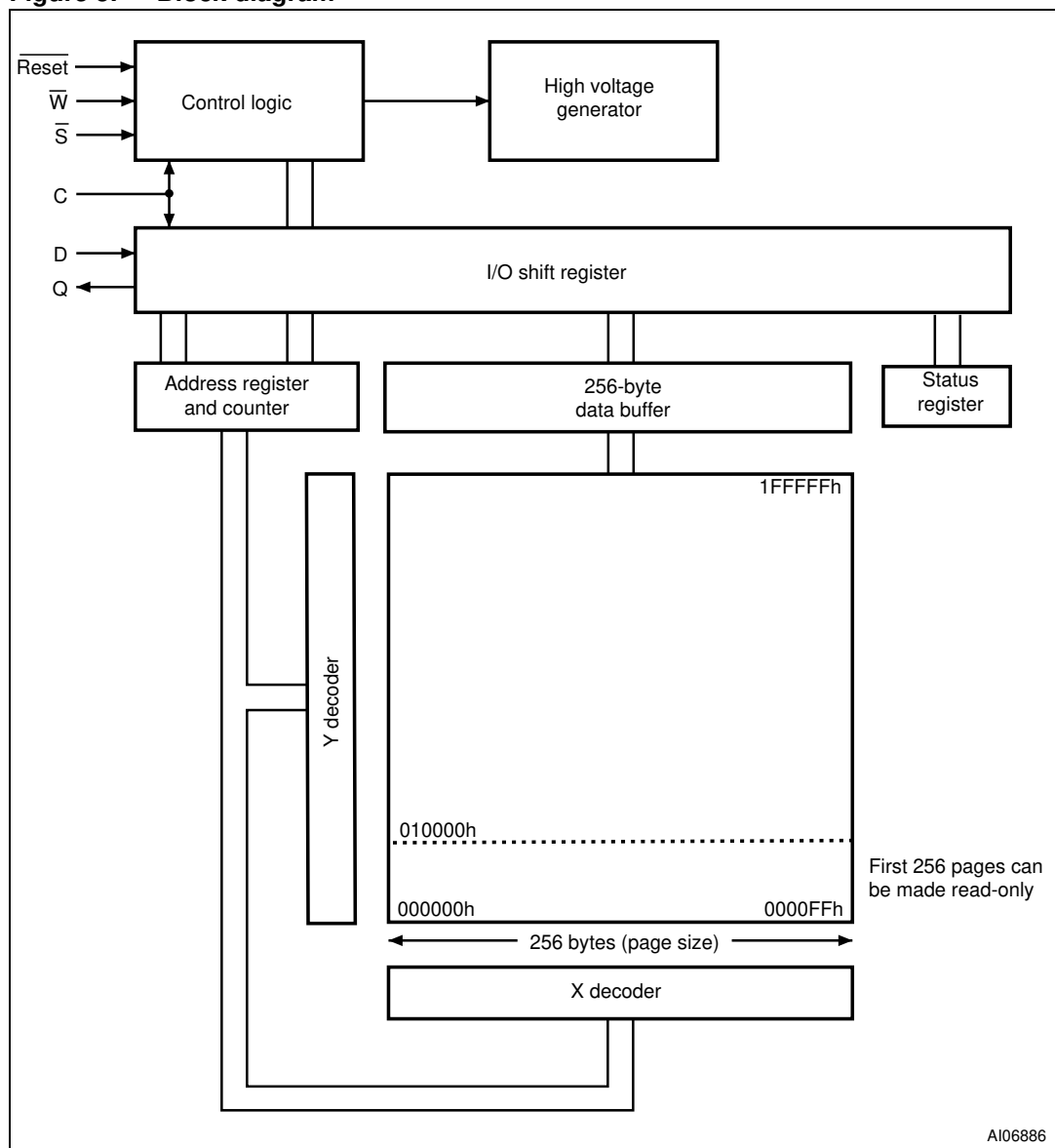

6 Instructions

All instructions, addresses and data are shifted in and out of the device, most significant bit first.

Serial data input (D) is sampled on the first rising edge of Serial Clock (C) after Chip Select (\bar{S}) is driven Low. Then, the one-byte instruction code must be shifted in to the device, most significant bit first, on serial data input (D), each bit being latched on the rising edges of Serial Clock (C).

The instruction set is listed in [Table 3](#).

Every instruction sequence starts with a one-byte instruction code. Depending on the instruction, this might be followed by address bytes, or by data bytes, or by both or none.

In the case of a read data bytes (READ), read data bytes at higher speed (FAST_READ) or read status register (RDSR) instruction, the shifted-in instruction sequence is followed by a data-out sequence. Chip Select (\bar{S}) can be driven High after any bit of the data-out sequence is being shifted out.

In the case of a page write (PW), page program (PP), page erase (PE), sector erase (SE), write enable (WREN), write disable (WRDI), deep power-down (DP) or release from deep power-down (RDP) instruction, Chip Select (\bar{S}) must be driven High exactly at a byte boundary, otherwise the instruction is rejected, and is not executed. That is, Chip Select (\bar{S}) must driven High when the number of clock pulses after Chip Select (\bar{S}) being driven Low is an exact multiple of eight.

All attempts to access the memory array during a write cycle, program cycle or erase cycle are ignored, and the internal write cycle, program cycle or erase cycle continues unaffected.

Table 3. Instruction set

Instruction	Description	One-byte instruction code		Address bytes	Dummy bytes	Data bytes
WREN	Write enable	0000 0110	06h	0	0	0
WRDI	Write disable	0000 0100	04h	0	0	0
RDID	Read identification	1001 1111	9Fh	0	0	1 to 3
RDSR	Read status register	0000 0101	05h	0	0	1 to ∞
READ	Read data bytes	0000 0011	03h	3	0	1 to ∞
FAST_READ	Read data bytes at higher speed	0000 1011	0Bh	3	1	1 to ∞
PW	Page write	0000 1010	0Ah	3	0	1 to 256
PP	Page program	0000 0010	02h	3	0	1 to 256
PE	Page erase	1101 1011	DBh	3	0	0
SE	Sector erase	1101 1000	D8h	3	0	0
DP	Deep power-down	1011 1001	B9h	0	0	0
RDP	Release from deep power-down	1010 1011	ABh	0	0	0

6.1 Write enable (WREN)

The write enable (WREN) instruction (*Figure 6*) sets the write enable latch (WEL) bit.

The write enable latch (WEL) bit must be set prior to every page write (PW), page program (PP), page erase (PE), and sector erase (SE) instruction.

The write enable (WREN) instruction is entered by driving Chip Select (\bar{S}) Low, sending the instruction code, and then driving Chip Select (\bar{S}) High.

Figure 6. Write enable (WREN) instruction sequence

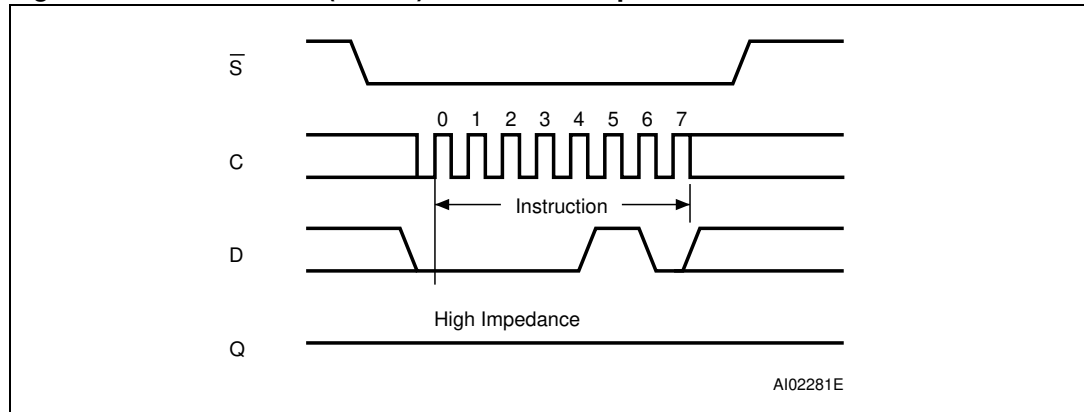

6.2 Write disable (WRDI)

The write disable (WRDI) instruction (*Figure 7*) resets the write enable latch (WEL) bit.

The write disable (WRDI) instruction is entered by driving Chip Select (\bar{S}) Low, sending the instruction code, and then driving Chip Select (\bar{S}) High.

The write enable latch (WEL) bit is reset under the following conditions:

- Power-up
- Write disable (WRDI) instruction completion
- Page write (PW) instruction completion
- Page program (PP) instruction completion
- Page erase (PE) instruction completion
- Sector erase (SE) instruction completion

Figure 7. Write disable (WRDI) instruction sequence

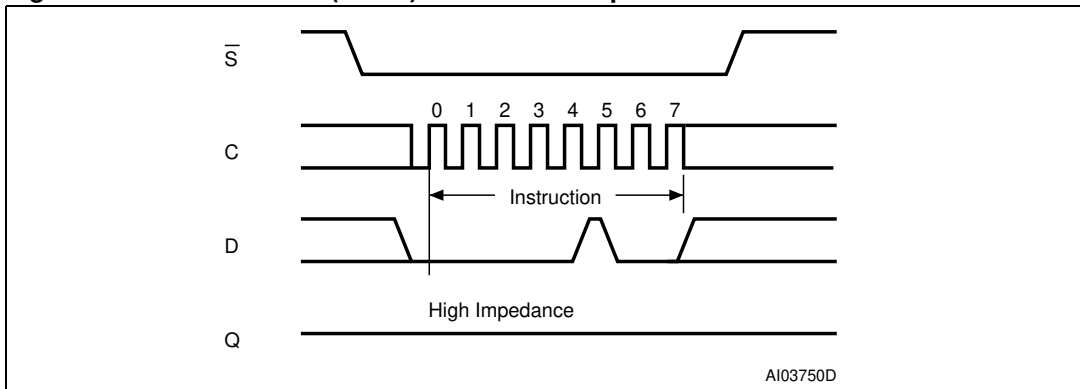

6.3 Read identification (RDID)

The read identification (RDID) instruction allows to read the device identification data:

- Manufacturer identification (1 byte)
- Device identification (2 bytes)
- A unique ID code (UID) (17 bytes, of which 16 available upon customer request).

The manufacturer identification is assigned by JEDEC, and has the value 20h for Numonyx. The device identification is assigned by the device manufacturer, and indicates the memory type in the first byte (40h), and the memory capacity of the device in the second byte (15h). The UID contains the length of the following data in the first byte (set to 10h), and 16 bytes of the optional customized factory data (CFD) content. The CFD bytes are read-only and can be programmed with customers data upon their demand. If the customers do not make requests, the devices are shipped with all the CFD bytes programmed to zero (00h).

Any read identification (RDID) instruction while an erase or program cycle is in progress, is not decoded, and has no effect on the cycle that is in progress.

The device is first selected by driving Chip Select (\bar{S}) Low. Then, the 8-bit instruction code for the instruction is shifted in. After this, the 24-bit device identification, stored in the memory, the 8-bit CFD length followed by 16 bytes of CFD content will be shifted out on serial data output (Q). Each bit is shifted out during the falling edge of Serial Clock (C).

The instruction sequence is shown in *Figure 8*.

The read identification (RDID) instruction is terminated by driving Chip Select (\bar{S}) High at any time during data output.

When Chip Select (\bar{S}) is driven High, the device is put in the standby power mode. Once in the standby power mode, the device waits to be selected, so that it can receive, decode and execute instructions.

Table 4. Read identification (RDID) data-out sequence

Manufacturer identification	Device identification		UID	
	Memory type	Memory capacity	CFD length	CFD content
20h	40h	15h	10h	16 bytes

Figure 8. Read identification (RDID) instruction sequence and data-out sequence

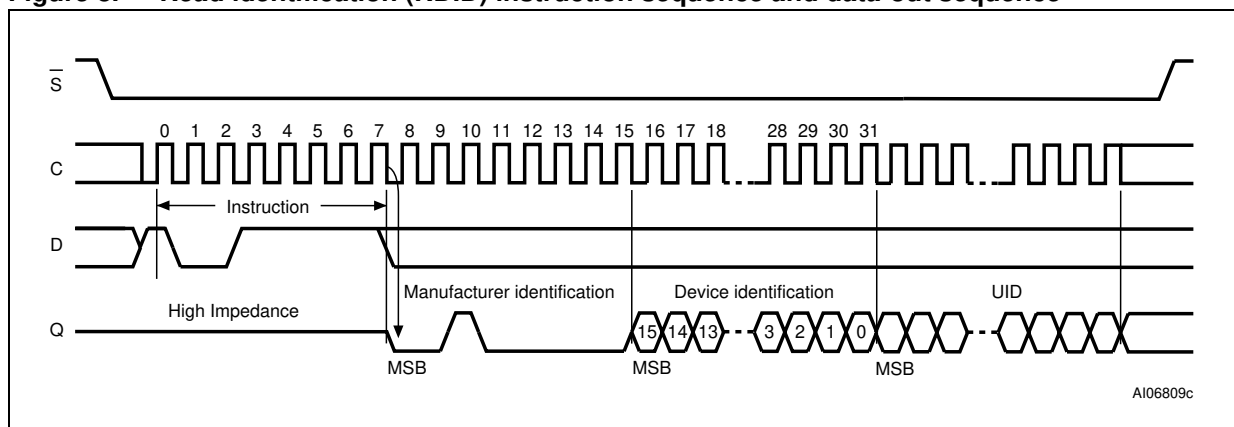

6.4 Read status register (RDSR)

The read status register (RDSR) instruction allows the status register to be read. The status register may be read at any time, even while a program, erase or write cycle is in progress. When one of these cycles is in progress, it is recommended to check the write in progress (WIP) bit before sending a new instruction to the device. It is also possible to read the status register continuously, as shown in *Figure 9*.

The status bits of the status register are as follows:

6.4.1 WIP bit

The write in progress (WIP) bit indicates whether the memory is busy with a write, program or erase cycle. When set to '1', such a cycle is in progress, when reset to '0' no such cycle is in progress.

6.4.2 WEL bit

The write enable latch (WEL) bit indicates the status of the internal write enable latch. When set to '1' the internal write enable latch is set, when set to '0' the internal write enable latch is reset and no write, program or erase instruction is accepted.

Table 5. Status register format

b7						b0	
0	0	0	0	0	0	WEL ⁽¹⁾	WIP ⁽¹⁾

1. WEL and WIP are volatile read-only bits (WEL is set and reset by specific instructions; WIP is automatically set and reset by the internal logic of the device).

Figure 9. Read status register (RDSR) instruction sequence and data-out sequence

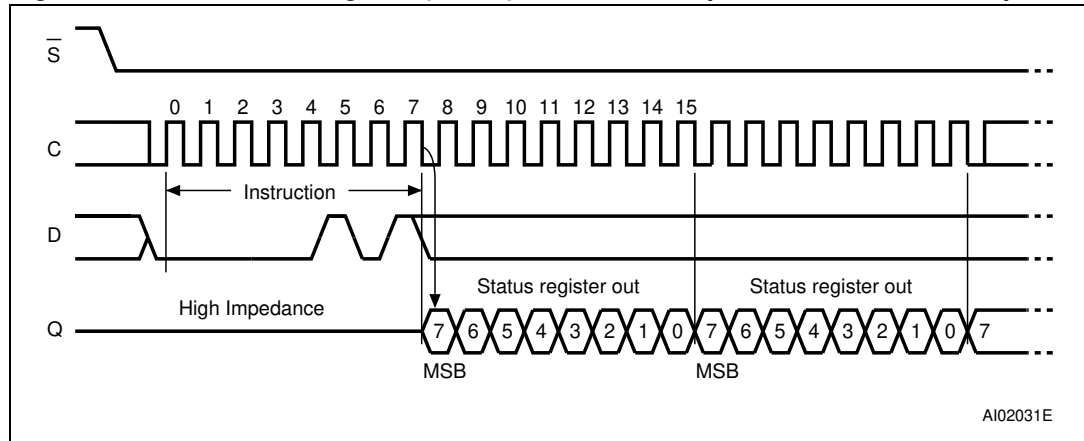

6.5 Read data bytes (READ)

The device is first selected by driving Chip Select (\bar{S}) Low. The instruction code for the read data bytes (READ) instruction is followed by a 3-byte address (A23-A0), each bit being latched-in during the rising edge of Serial Clock (C). Then the memory contents, at that address, is shifted out on serial data output (Q), each bit being shifted out, at a maximum frequency f_R , during the falling edge of Serial Clock (C).

The instruction sequence is shown in *Figure 10*.

The first byte addressed can be at any location. The address is automatically incremented to the next higher address after each byte of data is shifted out. The whole memory can, therefore, be read with a single read data bytes (READ) instruction. When the highest address is reached, the address counter rolls over to 000000h, allowing the read sequence to be continued indefinitely.

The read data bytes (READ) instruction is terminated by driving Chip Select (\bar{S}) High. Chip Select (\bar{S}) can be driven High at any time during data output. Any read data bytes (READ) instruction, while an erase, program or write cycle is in progress, is rejected without having any effects on the cycle that is in progress.

Figure 10. Read data bytes (READ) instruction sequence and data-out sequence

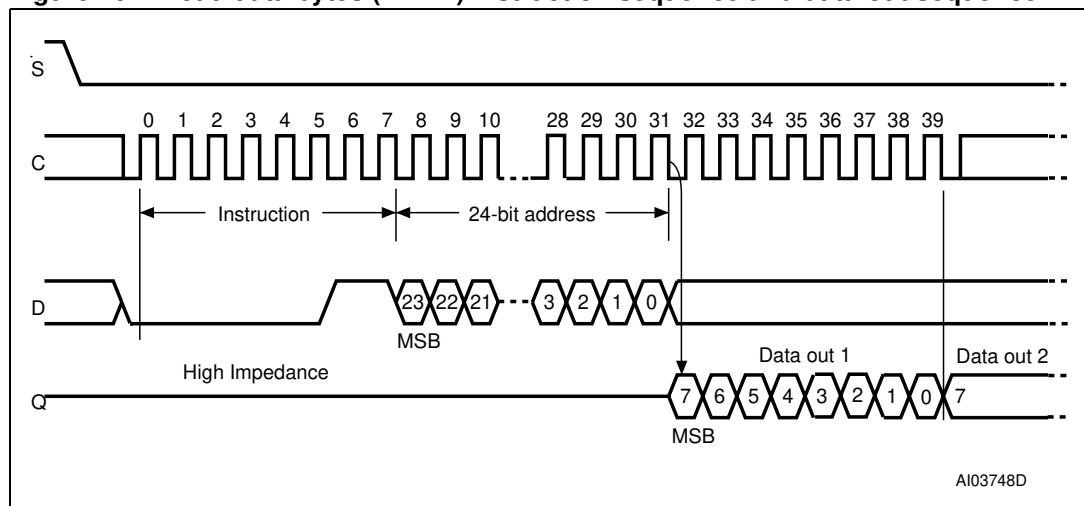

1. Address bits A23 to A21 are don't care.

6.6 Read data bytes at higher speed (FAST_READ)

The device is first selected by driving Chip Select (\overline{S}) Low. The instruction code for the read data bytes at higher speed (FAST_READ) instruction is followed by a 3-byte address (A23-A0) and a dummy byte, each bit being latched-in during the rising edge of Serial Clock (C). Then the memory contents, at that address, is shifted out on serial data output (Q), each bit being shifted out, at a maximum frequency f_C , during the falling edge of Serial Clock (C).

The instruction sequence is shown in *Figure 11*.

The first byte addressed can be at any location. The address is automatically incremented to the next higher address after each byte of data is shifted out. The whole memory can, therefore, be read with a single read data bytes at higher speed (FAST_READ) instruction. When the highest address is reached, the address counter rolls over to 000000h, allowing the read sequence to be continued indefinitely.

The read data bytes at higher speed (FAST_READ) instruction is terminated by driving Chip Select (\overline{S}) High. Chip Select (\overline{S}) can be driven High at any time during data output. Any read data bytes at higher speed (FAST_READ) instruction, while an erase, program or write cycle is in progress, is rejected without having any effects on the cycle that is in progress.

Figure 11. Read data bytes at higher speed (FAST_READ) instruction sequence and data-out sequence

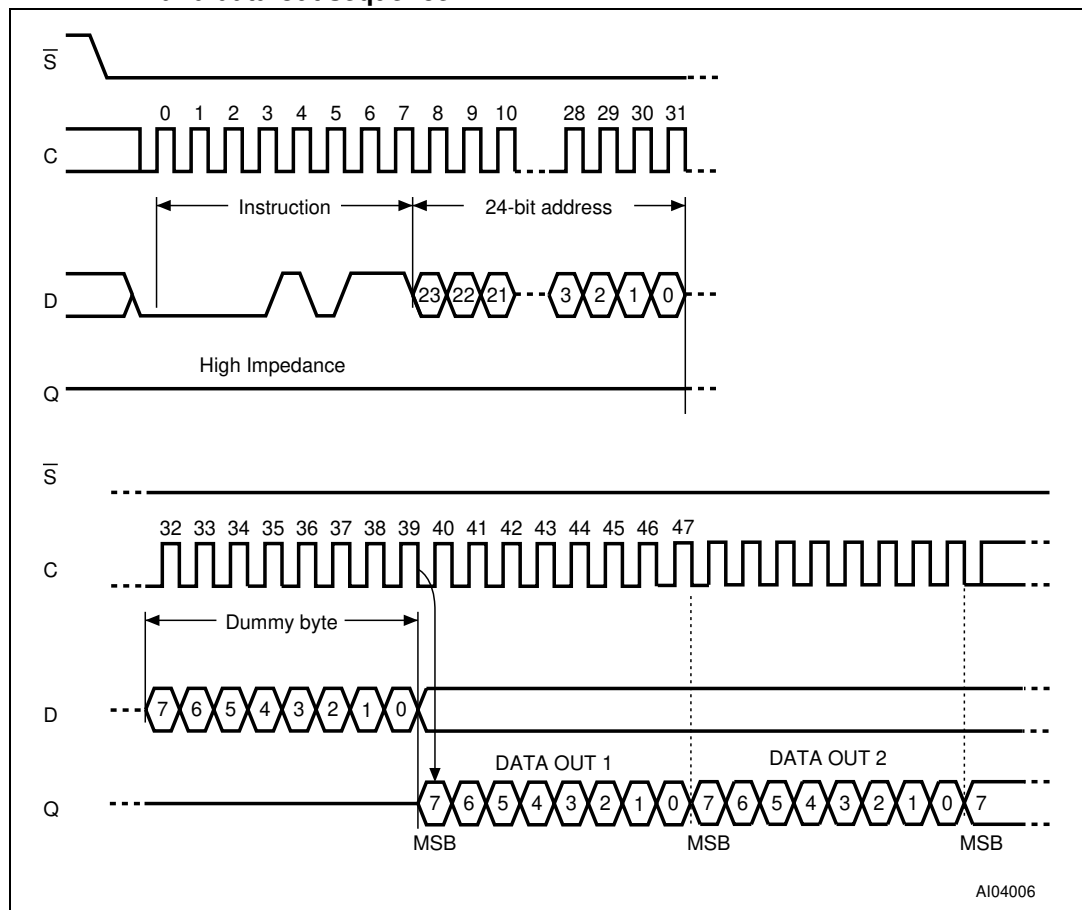

1. Address bits A23 to A21 are don't care.

6.7 Page write (PW)

The page write (PW) instruction allows bytes to be written in the memory. Before it can be accepted, a write enable (WREN) instruction must previously have been executed. After the write enable (WREN) instruction has been decoded, the device sets the write enable latch (WEL).

The page write (PW) instruction is entered by driving Chip Select (\bar{S}) Low, followed by the instruction code, three address bytes and at least one data byte on serial data input (D). The rest of the page remains unchanged if no power failure occurs during this write cycle.

The page write (PW) instruction performs a page erase cycle even if only one byte is updated.

If the 8 least significant address bits (A7-A0) are not all zero, all transmitted data exceeding the addressed page boundary roll over, and are written from the start address of the same page (the one whose 8 least significant address bits (A7-A0) are all zero). Chip Select (\bar{S}) must be driven Low for the entire duration of the sequence.

The instruction sequence is shown in [Figure 12](#).

If more than 256 bytes are sent to the device, previously latched data are discarded and the last 256 data bytes are guaranteed to be written correctly within the same page. If less than 256 data bytes are sent to device, they are correctly written at the requested addresses without having any effects on the other bytes of the same page.

For optimized timings, it is recommended to use the page write (PW) instruction to write all consecutive targeted bytes in a single sequence versus using several page write (PW) sequences with each containing only a few bytes (see [Table 12: AC characteristics - 50 MHz operation](#) and [Table 13: AC characteristics - 75 MHz operation](#)).

Chip Select (\bar{S}) must be driven High after the eighth bit of the last data byte has been latched in, otherwise the page write (PW) instruction is not executed.

As soon as Chip Select (\bar{S}) is driven High, the self-timed page write cycle (whose duration is t_{PW}) is initiated. While the page write cycle is in progress, the status register may be read to check the value of the write in progress (WIP) bit. The write in progress (WIP) bit is 1 during the self-timed page write cycle, and is 0 when it is completed. At some unspecified time before the cycle is complete, the write enable latch (WEL) bit is reset.

A page write (PW) instruction applied to a page that is hardware protected is not executed.

Any page write (PW) instruction, while an erase, program or write cycle is in progress, is rejected without having any effects on the cycle that is in progress.

Figure 12. Page write (PW) instruction sequence

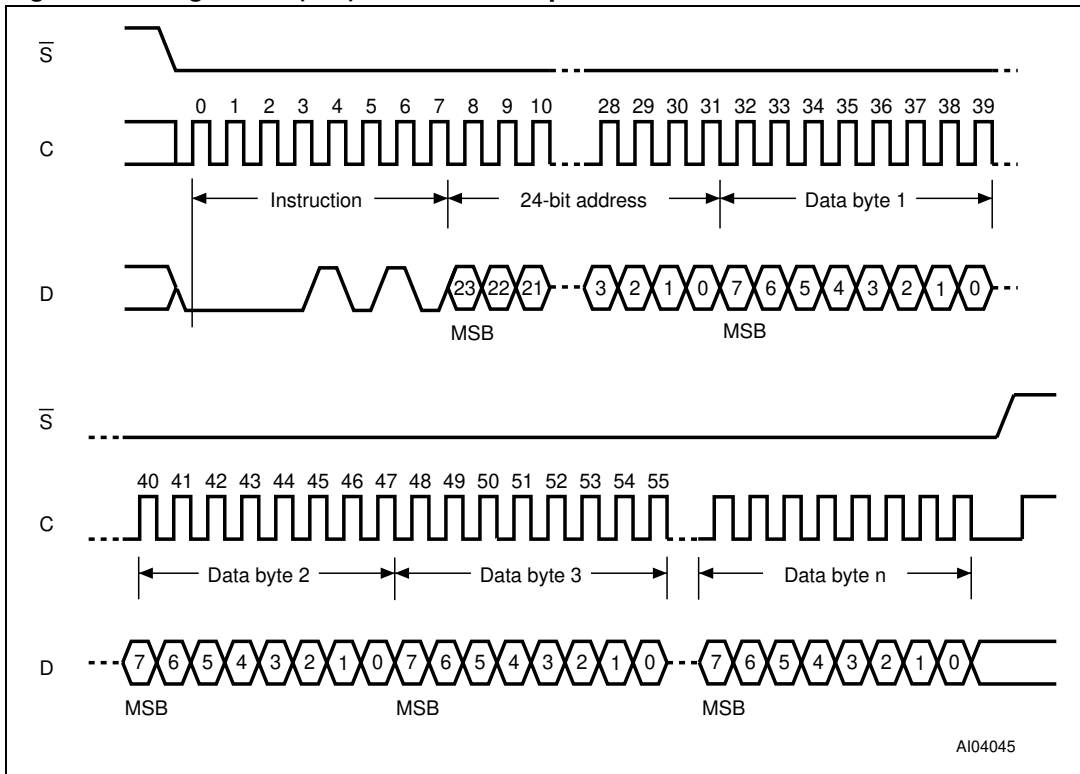

1. Address bits A23 to A21 are don't care.
2. $1 \leq n \leq 256$.