



Chipsmall Limited consists of a professional team with an average of over 10 year of expertise in the distribution of electronic components. Based in Hongkong, we have already established firm and mutual-benefit business relationships with customers from,Europe,America and south Asia,supplying obsolete and hard-to-find components to meet their specific needs.

With the principle of "Quality Parts,Customers Priority,Honest Operation,and Considerate Service",our business mainly focus on the distribution of electronic components. Line cards we deal with include Microchip,ALPS,ROHM,Xilinx,Pulse,ON,Everlight and Freescale. Main products comprise IC,Modules,Potentiometer,IC Socket,Relay,Connector.Our parts cover such applications as commercial,industrial, and automotives areas.

We are looking forward to setting up business relationship with you and hope to provide you with the best service and solution. Let us make a better world for our industry!



Contact us

Tel: +86-755-8981 8866 Fax: +86-755-8427 6832

Email & Skype: info@chipsmall.com Web: www.chipsmall.com

Address: A1208, Overseas Decoration Building, #122 Zhenhua RD., Futian, Shenzhen, China

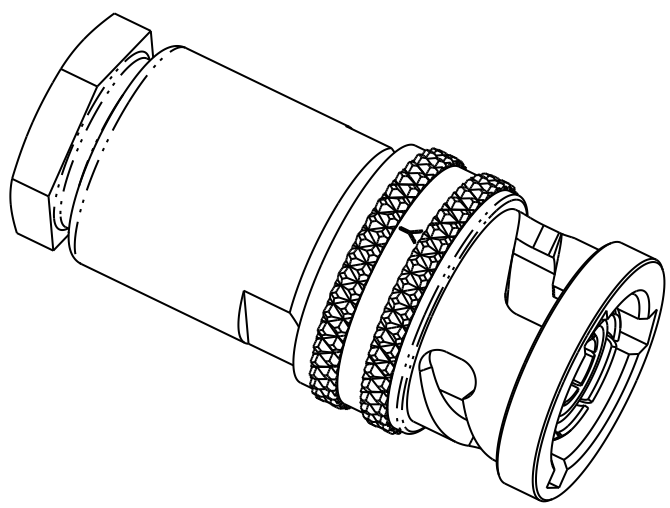
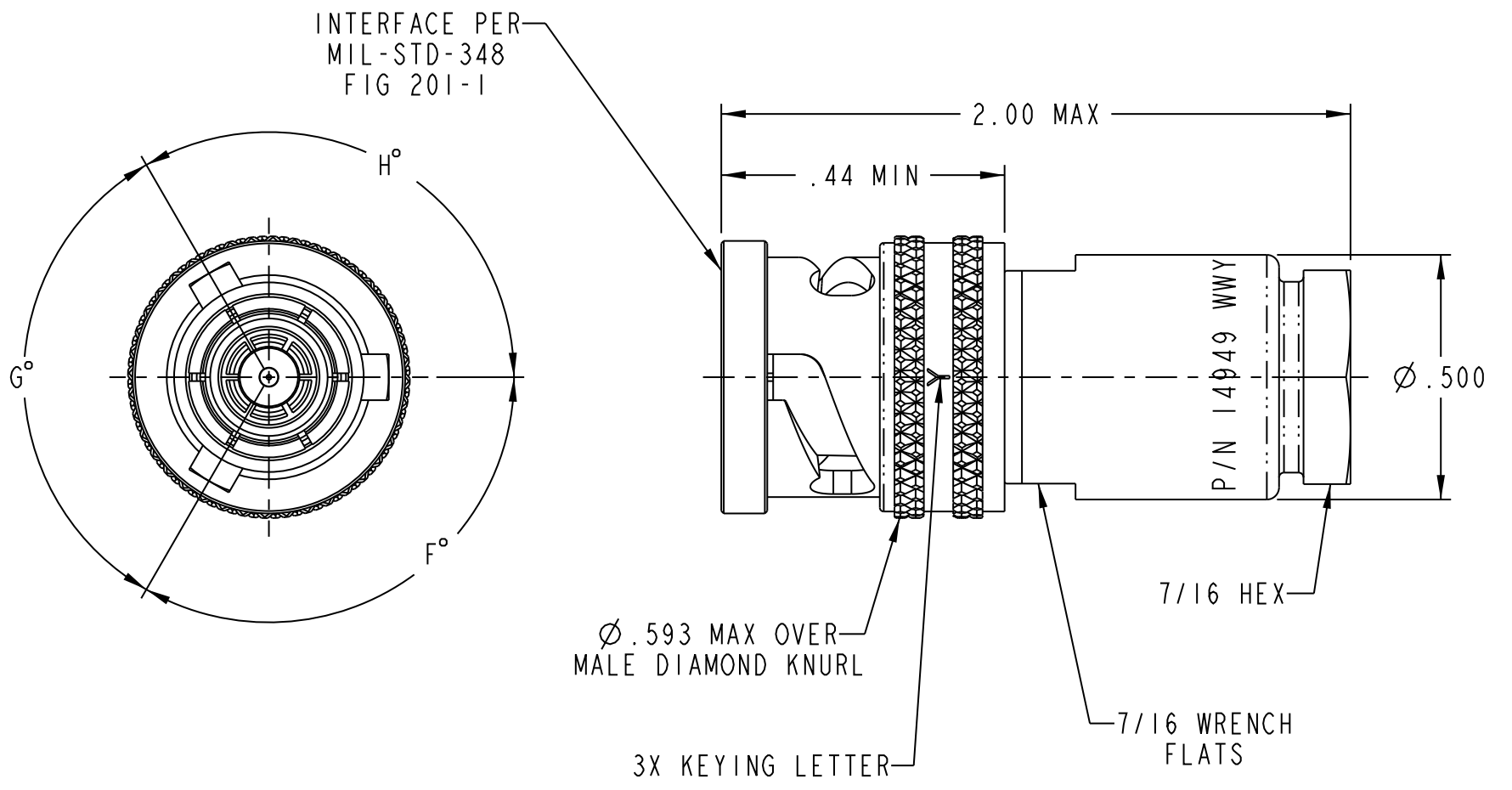

TABLE 1						
MILITARY PART NUMBER	MILITARY CABLE NUMBER	TEI DASH #	KEYING LETTER	ASSEMBLE PER	CABLE TYPE	NSN #
M49142/03-0001	M17/134-00001 M17/134-00003	7	NONE	TAI-189	TRIAX	5935011636242
M49142/03-0101	M17/134-00001 M17/134-00003	7	Y	TAI-189	TRIAX	—
M49142/03-0201	M17/134-00001 M17/134-00003	7	S	TAI-189	TRIAX	—
M49142/03-0002	M17/134-00002 M17/134-00004	7	NONE	TAI-189	TRIAX	5935014397867
M49142/03-0102	M17/134-00002 M17/134-00004	7	Y	TAI-189	TRIAX	—
M49142/03-0202	M17/134-00002 M17/134-00004	7	S	TAI-189	TRIAX	—
M49142/03-0005	M17/116-RG307	41A	NONE	TAI-250	TRIAX	5935014238648
M49142/03-0105	M17/116-RG307	41A	Y	TAI-250	TRIAX	—
M49142/03-0205	M17/116-RG307	41A	S	TAI-250	TRIAX	—
M49142/03-0007	M17/45-RG108 M17/186-00008	9	NONE	TAI-102	TWINAX	5935013358935
M49142/03-0107	M17/45-RG108 M17/186-00008	9	Y	TAI-102	TWINAX	—
M49142/03-0207	M17/45-RG108 M17/186-00008	9	S	TAI-102	TWINAX	—
M49142/03-0008	M17/176-00002	47	NONE	TAI-102	TWINAX	5935013783905
M49142/03-0108	M17/176-00002	47	Y	TAI-102	TWINAX	5935014277109
M49142/03-0208	M17/176-00002	47	S	TAI-102	TWINAX	—
M49142/03-0009	M17/177-00001	60	NONE	TAI-189	TRIAX	5935014675369
M49142/03-0109	M17/177-00001	60	Y	TAI-189	TRIAX	5935014675370
M49142/03-0209	M17/177-00001	60	S	TAI-189	TRIAX	—

TABLE 2			
KEYING LETTER	F°	G°	H°
NONE	120	120	120
Y	110	140	110
S	135	135	90

REVISIONS			
REV	DESCRIPTIONS	DATE	APPROVED
BU	ECO 54729	9/25/13	C. MONAHAN

DATA CONTAINED IN THIS DOCUMENT IS PROPRIETARY TO EMERSON CONNECTIVITY SOLUTIONS AND SHALL NOT BE DISCLOSED, COPIED OR USED FOR PROCUREMENT OR MANUFACTURE WITHOUT EXPRESS WRITTEN PERMISSION



NOTES: UNLESS OTHERWISE SPECIFIED.

INTERPRET DRAWING PER MIL-STD-100. DIMENSIONS ARE IN INCHES AND INCLUDE FINISH THICKNESS UNLESS OTHERWISE SPECIFIED.		TOL: UNLESS SPECIFIED. .XX ± .02 .XXX ± .010 .XXXX ± .0005 ANGLE ± 1° 00'		 Connectivity Solutions 299 Johnson Ave. Ste. 100 Waseca, MN 56093 1-800-247-8256	
DRN C. WALLACE	9/25/13	MATERIAL:	TITLE: M49142/03 WRENCH CRIMP PLUG		
CHK C. MONAHAN	10/14/14	FINISH:	SIZE B	CAGE CODE 14949	DRAWING NO. 310-0083
QUALITY			SCALE 3/1	DATE	REV. BU
MANUF			DO NOT SCALE DWG	SHEET 1 OF 2	
APPROVED					
SURFACE AREA	PROJ/FILE NO. 310-0083				