



Chipsmall Limited consists of a professional team with an average of over 10 year of expertise in the distribution of electronic components. Based in Hongkong, we have already established firm and mutual-benefit business relationships with customers from,Europe,America and south Asia,supplying obsolete and hard-to-find components to meet their specific needs.

With the principle of “Quality Parts,Customers Priority,Honest Operation,and Considerate Service”,our business mainly focus on the distribution of electronic components. Line cards we deal with include Microchip,ALPS,ROHM,Xilinx,Pulse,ON,Everlight and Freescale. Main products comprise IC,Modules,Potentiometer,IC Socket,Relay,Connector.Our parts cover such applications as commercial,industrial, and automotives areas.

We are looking forward to setting up business relationship with you and hope to provide you with the best service and solution. Let us make a better world for our industry!



Contact us

Tel: +86-755-8981 8866 Fax: +86-755-8427 6832

Email & Skype: info@chipsmall.com Web: www.chipsmall.com

Address: A1208, Overseas Decoration Building, #122 Zhenhua RD., Futian, Shenzhen, China



M5253 Demo Board User Manual

For M5253 Demo Evaluation/Application Development

by: Shen Li
System Engineer, Shanghai

The M5253 demo board is based on the Freescale V2 architecture family chip, the MCF5253. This board is shipped with the MCF5253 populated to show the functionality of this family.

This board is designed as a validation platform with the maximum flexibility. It serves as a complete microcomputer system for reference design, development/evaluation, training, and educational use. Further more, the board also includes an ethernet controller on the system FlexBus for debugging and developing purposes.

Contents

1	Demo Board Overview	2
1.1	Features	2
1.2	Block Diagram	3
2	Top-Level Memory Map	3
3	Hardware Submodules	4
3.1	Processor	4
3.2	Resets	4
3.3	System Clock	4
3.4	Bootting and Programming the Flash/EEPROM Memory	5
3.5	SDRAM Interface	6
3.6	BDM Interfaces — Processor	6
3.7	USB 2.0 OTG	6
3.8	FEC	7
3.9	ATA	7
3.10	Interrupts	7
3.11	Timers	7
3.12	I2C	8
3.13	QSPI	8
3.14	RS232	8
3.15	SD Card Interface	8
3.16	Audio Interface	8
3.17	AD Module	8
3.18	CAN Interface	9
3.19	Power Regulation	9
3.20	Boot Options	9
3.21	Serial connector	10
3.22	Parallel connector	10
3.23	Jumpers and Headers	12

1 Demo Board Overview

1.1 Features

Here is a list of the demo board features. The MCF5253's external interfaces are:

- Synchronous serial interface (SSI) connected to the audio codec WM8731
- USB support
- Stand-alone USB host controller, support-enhanced host-controller interface (EHCI)
- USB device mode
- USB on-the-go mode including host capability
- Supports high-speed (480 Mbps), full-speed (12 Mbps), and low-speed host (1.5Mbps) operations
- Supports internal PHY (with UTMI+ interface)
- Crystal/clock
- On-board BDM™
- ATA interface
- MMC/SD interface
- Two I²Cs
- Four QSPIs
- Two CANs
- Three UARTs
- Six 12-bit resolution ADs
- FlexBus with 10/100 ethernet controller
- Timers
- External interrupts

Memory Subsystems:

- 16-bit width SDRAM
- 2 × 64 KB SRAM
- 8 k on-chip BootROM
- Flash device for boot code development

Power:

- Inputs:
- 5 V (Input to the voltage regulator circuitry)
- Regulated on-board voltages:
 - 5 V for USB-VBUS support
 - 3.3 V — I/O Voltage
 - 1.2 V — CPU-core voltage

1.2 Block Diagram

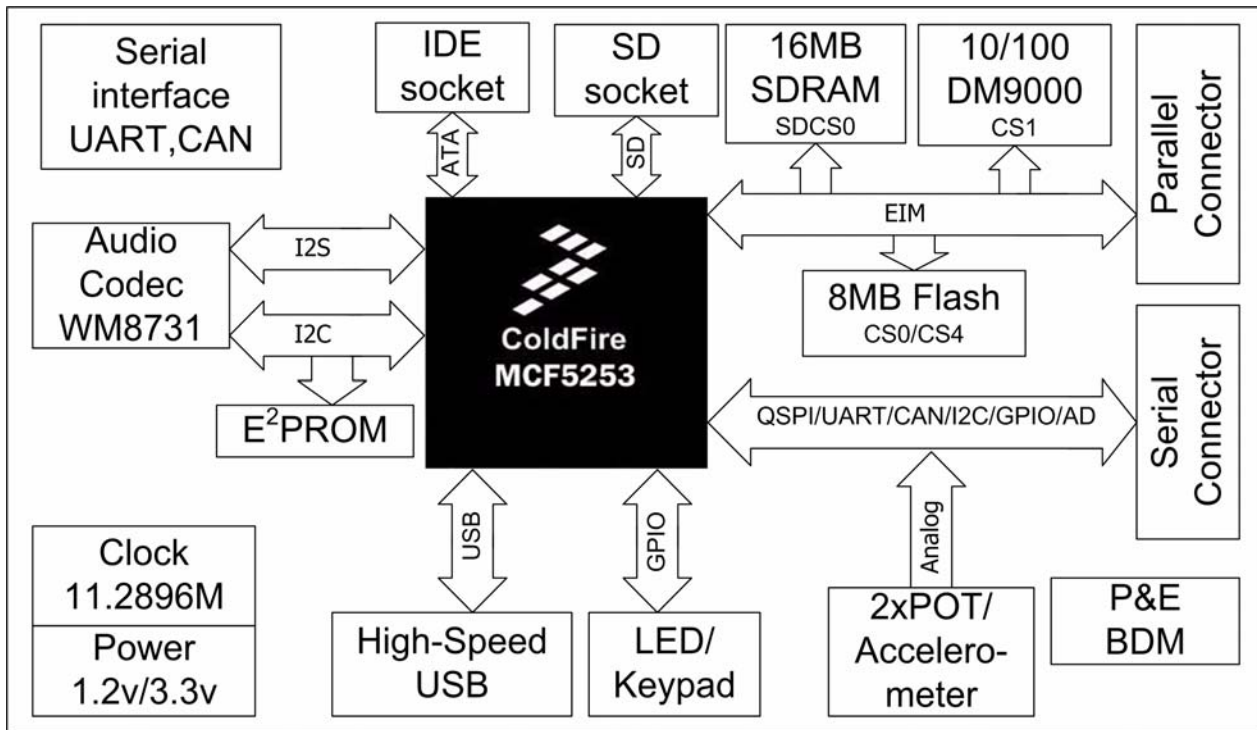

Figure 1. M5253 Demo Board Block Diagram

2 Top-Level Memory Map

The top-level memory map for the M5253 demo board is shown below. This is best for understanding how the entire memory map of the board is set up.

Table 1. Top-Level Memory Map

Function	Start Address	End Address	Size
SDRAM	0x0000_0000	0x00FF_FFFF	16 MB
SIM MBAR	0x1000_0000	0x1000_0058	96B
Internal SRAM0	0x2000_0000	0x2000_FFFF	64KB
Internal SRAM1	0x2001_0000	0x2001_FFFF	64KB
SIM MBAR2	0x8000_0000	0x8000_01FF	512B
Ethernet Controller DM9000 (CS1)	0xE000_0300	0xE000_03FF	64B
FLASH (CS0)	0xFF80_0000	0xFFFF_FFFF	8MB

3 Hardware Submodules

This section describes the major sections of the M5253 demo board.

3.1 Processor

The MCF5253 processor is the fundamental control chip on the M5253 demo board. This is a version 2 (V2) ColdFire processor running at a maximum core speed of 140 MHz. MCF5253 implements an 8 KB instruction cache, three UART channels, two timers, 128 KB of SRAM, a QSPI (queued serial peripheral interface) module, two I²C modules, three I²S modules, an IDE module, a dedicated ATA interface with DMA support, two FlexCAN modules, an OTG USB 2.0 controller with integrated physical interface, real-time clock (RTC), a flash memory stick interface, 60 parallel I/O ports (which are multiplexed with other signals), and the system integration module (SIM). All of the core-processor registers are 32 bits wide except for the status register (SR) which is 16 bits wide. This processor communicates with the external devices over a 16 bits wide data bus, D[31:16]. The processor has a logic to generate up to four chip selects, and support for a bank of SDRAMs. This board has brought out almost every silicon feature for evaluation and developing the customer design.

3.2 Resets

The system reset signal is coming from the power management IC MC34702 with a reset button. The reset signal feeds the CPU, flash, BDM, and DM9000 devices. This signal also appears on the connector J17 for external use.

3.3 System Clock

This board uses a 11.2896 MHz crystal for the system main clock input CRIN.

The system PLL output-clock equation is as follows:

Eqn. 1

$$PSTCLK = Fin \times \frac{2 \times VCXODIV}{PLL DIV \times CPUDIV \times VCXOOUT}$$

Following table is the clock configuration:

Table 2. System Clock Configuration

Fin (MHz)	CPUDIV	CRSEL	VCXODIV	PLLDIV	VCXOOUT	PSTCLK (MHz)
11.2896	2	0	62	5	1	140 (default)
11.2896	2	0	42	4	1	120
11.2896	3	0	51	4	1	96
11.2896	4	0	51	4	1	72

Here is the example code to configure the system running at 140 MHz:

```

...
MCF_CLOCK_PLLCONFIG = 0x1243E054;
MCF_CLOCK_PLLCONFIG = 0x1243E055;
/* Wait for PLL to lock */
while (!(MCF_CLOCK_PLLCONFIG & MCF_CLOCK_PLLCONFIG_LOCK))
;
...

```

Audio module also uses the 11.2896 MHz frequency for operation, so Faudio = AUDIOCLK = CRIN (A20/A24 switch pull up, down).

3.4 Booting and Programming the Flash/EEPROM Memory

This demo board includes both a serial boot EEPROM and the program flash memories on-board.

3.4.1 Serial Boot EEPROM

The serial boot EEPROM (AT24C256) can store configuration parameters and the boot code. It is I²C bus EEPROM and the address is 1010000x (x means R/W#-bit).

When the MCF5253 boot mode is configured as I²C master boot (A23 pull down and GPIO50 = 0, GPIO49 = 0, GPIO48 = 0) the MCF5253 loads the boot code from the I²C EEPROM at powerup. The board uses this EEPROM just for a demonstration of the MCF5253's serial-boot function. There is no pre-flashed software inside the EEPROM. Customer can put his own boot code there and configure the data into this device. Please see [Table 4](#) for more details about the serial-boot configuration.

3.4.2 Flash

A 8 MB (4Mx16) flash (SST39VF6401) memory resides on the CS0 space of the FlexBus memory on the demo board. The software must configure the memory-access parameters to be consistent with the hardware configuration. The SST39VF6401 is uniformed as 2 Kword sectors, totally in 2 K sectors.

When the MCF5253 boot mode is configured as CS0/CS4 boot (A23 pullup), the CPU loads the code from the flash at powerup. We intended to reside the dBUG or U-boot as the bootloader at the beginning of the flash memory.

Flash address
0xFF80_0000 ~ 0xFFFF_FFFF

The CS0 initialization code is below:

```

...
; CS0 = Flash SST39VF6401B - 8Mbytes
writemem.w 0x10000080 0xFF80 ; CSAR0 - FlashBase = 0xFF80_0000 - 0xFFFF_FFFF
writemem.w 0x1000008A 0x0D80 ; CSCR0
writemem.l 0x10000084 0x007F0021 ; CSMR0 - 0xFF80_0000 - 0xFFFF_FFFF
...

```

3.5 SDRAM Interface

The M5253 demo board provides 16 MB of on-board SDRAM, which is located at 0x0. The on-board terminations are provided. The software should take notice of the timing configuration of this device for the SDRAM controller module.

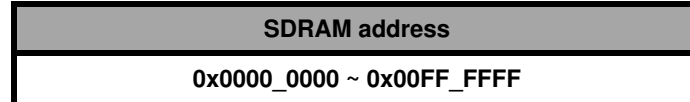

The SDRAM timing characters are listed below:

tRCD > 20 ns

CASL = 2 CLK

45 ns < tRAS < 100 ns

tRP > 20 ns

tRWL, RDL = 1 CLK (less than 100 MHz speed)

Here is the initialization code example for the SDRAM controller:

```
...
; set up 5253 cpu settings
; initialize memory settings SDRAM base Address 0x0000_0000
writemem.w 0x10000100 0x8209 ;SDRAM0 DCR0A
writemem.l 0x10000108 0x00002320 ;SDRAM0 DACR0A
writemem.l 0x1000010C 0x00FC0001 ;SDRAM0 DMR0A
writemem.l 0x10000108 0x00002328 ;SDRAM0 DACR0B
writemem.l 0x00000000 0x00000000 ;SDRAM0 MEMWRO
writemem.l 0x10000108 0x0000A320 ;SDRAM0 DACR0C
writemem.l 0x10000108 0x0000A360 ;SDRAM0 DACR0D
writemem.l 0x00000800 0x00000800 ;SDRAM0 MODE0...
```

3.6 BDM Interfaces — Processor

The M5253 demo board provides an on-board BDM (background debug mode) module and a connector (26-pin header) to give the final user the ability to utilize the BDM features of the MCF5253 processor. With the on-board BDM, the customer can use a USB A-to-B cable for debugging and downloading the software. The 26-pin header is not populated on the board by default, the customer can populate it on the J14. To enable the header, the customer also needs to populate four 0 Ω resistors on R4 to R7.

3.7 USB 2.0 OTG

The MCF5253 processor contains a USB high-speed OTG module. This module is USB 2.0 compliant. It supports both the host and the device modes, and provides an on-chip high-speed/full-speed/low-speed transceiver. One mini-AB receptacle (USB 2.0 OTG) is provided on the Jamaica board. The board also provides an external power distribution switch (MIC2026) to provide the VBUS when necessary. The USB module uses a 24 MHz crystal for module clock.

When jumpers J32 and J26 are installed, the MIC2026 can output a maximum of 500 mA 5V power to the VBUS, working in the USB-host mode. When working in the device and otg mode, the J32 and J26 should be disconnected.

3.8 FEC

The M5253 demo provides a 10/100M ethernet interface by an ethernet controller DM9000 on the CS1 of the FlexBus. The board also provides the RJ45 connectors with integrated magnetics and LEDs. As there is no EEPROM for the DM9000 on this board, there is no default MAC address configured for the M5253 demo board. The software takes the response to configure the MAC address of the DM9000 after powerup, but Freescale has assigned a unique ethernet MAC address for each board and pasted it on the back of the board. DM9000's system address is at 0xE000_0300. The address index port is 0xE000_0300 and the data port is 0xE000_0304. The DM9000's interrupt pin (active high default) uses the system external interrupt GPI5. The GPI5 L-H event is the second interrupt at controller number 37.

3.9 ATA

The M5253 demo board provides an ATA connector that interfaces with the MCF5253 processor's ATA interface. This board only supports one ATA device on the cable. To support a multi-ATA harddisk, the CSEL signal on the board must be connected to the GND according to the ATA/ATAPI-6 specification, because the board does not support it.

A device connected to the ATA interface must be powered by a separate supply (such as a peripheral power connector provided by the ATX power supply).

3.10 Interrupts

The MCF5253 has a total number of seven external-interrupt input pins GPI0~6. Four of them are connected to the push-button on the M5253 demo board and they are the GPI1~4's. The GPI5 is reserved for the ethernet controller DM9000. The GPI6 is reserved for customer usage. The external interrupt pins are all multiplexed with other modules.

3.11 Timers

The MCF5253 contains a software watchdog timer and two 16-bit general-purpose timers (GPT).

The software watchdog timer provides a means of preventing the system from lockup due to uncontrolled software loops via a special software-service sequence.

The two general-purpose timer modules (timer 0 and timer 1) in the MCF5253 can provide two independent system interrupts, but only timer 1 can provide an output signal as TOUT1. It is multiplexed with the SDATA01.

3.12 I²C

MCF5253 has two I²C modules (I²C0 and I²C1) and is fully compatible with the I²C-bus standard. On the M5253 demo board, the I²C0 is connected to the EEPROM, the audio codec, and the power manager. The I²C1 is reserved for customer usage.

Here is a list of the I²C device default addresses on the I²C0.

Table 3. I²C Device Addresses

I ² C Device	I ² C address
EEPROM	0b1010000x
WM8731	0b0011010x
MC34702	0b1110111x

3.13 QSPI

The MCF5253's QSPI module has up to seven signals: QSPI_Dout, QSPI_Din, QSPI_CLK, and QSPI_CS[3:0]. On the M5253 demo board, the QSPI module is not connected to any QSPI device, but is just routed out at the serial connector.

3.14 RS232

The MCF5253 includes three UART modules. To reduce the board's dimensions and cost down, we consider that the three UART's should share the transceiver and the DB9 connector with the jumpers J12, J13, J20, and J24.

3.15 SD Card Interface

The MCF5253 has a flash media interface which can interface with the Sony Memory Stick and Multi-Media Card (MMC)/Secure Digital (SD) flash cards. The M5253 demo board installs an MMC/SD socket for evaluation and verification.

3.16 Audio Interface

The MCF5253 contains an audio interface module (AIM) which is equipped with three serial-audio interfaces compliant with the Phillips I2S and Sony EIAJ formats. The M5253 demo reserves an audio AD/DA IC WM8731 for the audio application development. It is connected to I2S1 by default. The MCLK signal has a frequency of 11.1896 MHz and comes from the MCF5253. The WM8731 is Wolfson's low-power stereo codec with an integrated headphone driver. It implements stereo 24-bit multi-bit sigma-delta ADCs and DACs with oversampling, digital interpolation, and decimation filters.

3.17 AD Module

The MCF5253 has a 12-bit 6-channel analog-to-digital module. The M5253 demo board provides a 3-axis accelerator and two potentiometers connected to the ADIN0~4 for demonstration. The analog channels are

also routed out at the serial connector J17 for customer use. Customer can use the on-board jumpers J5 and J27 to control the analog input of each channel.

3.18 CAN Interface

The MCF5253 has two CAN-bus interfaces. The M5253 demo board provides one CAN transceiver with a DB9 connector. There is a 120 Ω loopback load resistor, which represents the impedance of the system on the CAN bus.

3.19 Power Regulation

The M5253 demo board provides a Freescale QuiccSupply MC34702 power regulator. The MC34702 is Freescale's power management IC, which incorporates a high-performance switching regulator and a low-dropout (LDO) linear-regulator control circuit. This power regulator provides a 3.3 V voltage by switching the regulator module for the microprocessor I/O and bus voltage and 1.2 V voltage from LDO for the CPU-core voltage supply. The regulator generates these voltages from a 5 V external supply. The 5 V supply can be provided through the power-jack connector. The MCF5253 has an internal LDO that can also generate a 1.2 V voltage and the J15 is to select which of the 1.2 V voltages is to be used.

3.20 Boot Options

The MCF5253 has two boot options:

- Booting from the FlexBus CS0/CS4 with default boot options.
- Booting from the internal bootROM and override defaults with the serial-boot facility.

The boot mode is determined by the logic level of the pin A23 during the powerup reset. When the A23 is pulled up during the powerup, the CPU will boot from the memory connected to the CS0/CS4, which is the flash on the M5253 demo board. The J21 on the board selects the boot option.

When the A23 is pulled down during the powerup, the CPU will boot from the on-chip boot ROM. The GPIO48~50 pin's logic will be sensed at the powerup to decide further boot options. On the M5253 demo board, the J29, J31, and J30 are to select the logic of the GPIO48~50. Here is the boot table:

Table 4. Boot Options of the On-Chip ROM

BOOT MODE	GPIO50/PST0 (J30)	GPIO49/PST1 (J31)	GPIO48/PST2 (J29)
I ² C master (default)	0	0	0
SPI master	0	0	1
IDE master	0	1	0
I ² C slave	1	0	0
UART (5.6448/11.2896 MHz)	1	0	1
UART (8.4672/16.9344/ 33.8688 MHz)	1	1	0
UART (5/10/20 MHz)	1	1	1

* - means default setting, 0 - means the signal to be pulled to ground, 1 - means the signal to be pulled high

3.21 Serial Connector

Table 5 is the signal definition of the serial connector J17.

Table 5. Serial Connector J17

1	3.3 V		2	CTS0#/IRQ4/GPI3
3	GND		4	5 V
5	TXD0/GPIO45		6	RSTO
7	RXD0/GPIO46		8	CTS1#/IRQ2/GPI1
9	SDATAI1/GPIO17		10	EBUIN1/GPIO36
11	SDATAO1/GPIO18		12	EBUIN2/GPIO13
13	LRCK1/GPIO19		14	EBUIN3/GPIO14
15	SCLK1/GPIO20		16	EBUOUT1/GPIO37
17	QSPI_OUT/GPIO27		18	SDATAO2/GPIO34
19	QSPI_DIN/GPIO26		20	LRCK2/GPIO23
21	QSPI_CLK/GPIO25		22	SCLK2/GPIO22
23	QSPI_CS0/GPIO15		24	SDATAI3/GPIO8
25	QSPI_CS1/GPIO16		26	SCL1/TXD1/GPIO10
27	QSPI_CS2/MCLK2/GPIO24		28	SDA1/RXD1/GPIO44
29	LRCK3/GPIO43		30	SCLK3/GPIO35
31	TXD2/IRQ1/GPI0		32	MCLK1/GPIO11
33	RTS1#/IRQ3/GPI2		34	AN0/GPI52
35	RTS0#/IRQ5/GPI4		36	AN1/GPI53
37	RXD2/IRQ7/GPI6		38	AN2/GPI54
39	PSTCLK/GPIO51		40	AN3/GPI55
41	AN5/GPI57		42	AN4/GPI56

3.22 Parallel Connector

Table 6 is the signal definition of the parallel connector J34.

Table 6. Parallel Connector J34

1	3.3 V		2	A1
3	GND		4	A2
5	A3		6	A4
7	A5		8	A6
9	A7		10	A8
11	A9		12	A10
13	A11		14	A12
15	A13		16	A14
17	A15		18	A16
19	A17		20	A18
21	A19		22	A20/A24
23	A21		24	A22
25	A23/GPIO54		26	D16
27	D17		28	D18
29	D19		30	D20
31	D21		32	D22
33	D23		34	D24
35	D25		36	D26
37	D27		38	D28
39	D29		40	D30
41	D31		42	RW
43	OE#		44	CFLG/IRQ6/GPI5
45	RSTO		46	BCLK/GPIO40
47	TA#/GPIO12		48	IDE_DIOR#/GPIO31
49	IDE_DIOW#/GPIO32		50	IDE_IORDY#/GPIO33
51	CS0#/CS4#		52	CS1#/GPIO28
53	BUFENB1#/GPIO29		54	BUFENB2#/GPIO30
55	WAKEUP#/GPIO21		56	PST3/GPIO47
57	PST2/GPIO48		58	PST1/GPIO49
59	PST0/GPIO50		60	GND

3.23 Jumpers and Headers

There are several jumpers on the M5253 demo board that allow the user to control the hardware configuration. The following table provides descriptions for all the jumper settings.

Table 7. Jumper Settings

Reference Designator	Setting ¹²	Function
J21	*1:2*	BOOT from CS0
	2:3	BOOT from internal ROM(for serial bus boot)
J29,J30,J31	Refer Table 4 for detail(no shunt default)	
J16	1:2	Audio CLK from LRCK3 PIN
	2:3	Audio CLK from CRIN PIN
J26,J32	ON	USB host enable
	OFF	USB device/otg mode
J25	ON	I²C0/SDATA pin use for SD socket function
	OFF	I²C0/SDATA pin not use for SD socket function
J23	*ON*	I²C0/SDATA pin use for I²C0
	OFF	I²C0/SDATA pin not use for I²C0
J10	*ON*	WM8731 MCLK come from MCLK2 of MCF5253
	OFF	WM8731 MCLK come from the on crystal beside
J5(2x2)	2× *ON*	AD 0,1 input from on board potentiometer
	OFF	AD 0,1 not input from on board potentiometer
J27(2x3)	3× *ON*	AD 2,3,4 input from on board 3-axis accelerator
	OFF	AD 2,3,4 not input from on board 3-axis accelerator
J7(2x2)	ON	BUFEN1# and TXD2 used for GPIO for SD socket
	OFF	BUFEN1# and TXD2 not used for GPIO for SD socket
J24	*1:2*	RXD signal come from RXD0
	3:4	RXD signal come from RXD1
	5:6	RXD signal come from RXD2

Table 7. Jumper Settings (continued)

J13	*1:2*	TXD signal come from TXD0
	3:4	TXD signal come from TXD1
	5:6	TXD signal come from TXD2
J20	*1:2*	RTS# signal come from RTS0#
	3:4	RTS# signal come from RTS1#
J12	*1:2*	CTS# signal come from CTS0#
	3:4	CTS# signal come from CTS1#
J14	*1:2*	CANTX signal come from CAN0_TX
	3:4	CANTX signal come from CAN1_TX
J18	*1:2*	CANRX signal come from CAN0_RX
	3:4	CANRX signal come from CAN1_RX
J8	ON	CAN bus terminator 120ohm connected
	OFF	CAN bus terminator 120ohm unconnected
J6	*1:2*	5v input come from power jack
	2:3	5v input come from the BDM module
J15	*1:2*	1.2 V core voltage come from power manage IC
	2:3	1.2 V core voltage come from MCF5253 internal LDO

¹ * indicates the default setting

² On indicates that a shunt should be fitted on the jumper; Off indicates that no shunt should be applied

How to Reach Us:

Home Page:

www.freescale.com

Web Support:

<http://www.freescale.com/support>

USA/Europe or Locations Not Listed:

Freescale Semiconductor, Inc.
Technical Information Center, EL516
2100 East Elliot Road
Tempe, Arizona 85284
+1-800-521-6274 or +1-480-768-2130
www.freescale.com/support

Europe, Middle East, and Africa:

Freescale Halbleiter Deutschland GmbH
Technical Information Center
Schatzbogen 7
81829 Muenchen, Germany
+44 1296 380 456 (English)
+46 8 52200080 (English)
+49 89 92103 559 (German)
+33 1 69 35 48 48 (French)
www.freescale.com/support

Japan:

Freescale Semiconductor Japan Ltd.
Headquarters
ARCO Tower 15F
1-8-1, Shimo-Meguro, Meguro-ku,
Tokyo 153-0064
Japan
0120 191014 or +81 3 5437 9125
support.japan@freescale.com

Asia/Pacific:

Freescale Semiconductor China Ltd.
Exchange Building 23F
No. 118 Jianguo Road
Chaoyang District
Beijing 100022
China
+86 10 5879 8000
support.asia@freescale.com

For Literature Requests Only:

Freescale Semiconductor Literature Distribution Center
P.O. Box 5405
Denver, Colorado 80217
1-800-441-2447 or 303-675-2140
Fax: 303-675-2150
LDCForFreescaleSemiconductor@hibbertgroup.com

Document Number:

Rev. 0

10/2008

Information in this document is provided solely to enable system and software implementers to use Freescale Semiconductor products. There are no express or implied copyright licenses granted hereunder to design or fabricate any integrated circuits or integrated circuits based on the information in this document.

Freescale Semiconductor reserves the right to make changes without further notice to any products herein. Freescale Semiconductor makes no warranty, representation or guarantee regarding the suitability of its products for any particular purpose, nor does Freescale Semiconductor assume any liability arising out of the application or use of any product or circuit, and specifically disclaims any and all liability, including without limitation consequential or incidental damages. "Typical" parameters that may be provided in Freescale Semiconductor data sheets and/or specifications can and do vary in different applications and actual performance may vary over time. All operating parameters, including "Typicals", must be validated for each customer application by customer's technical experts. Freescale Semiconductor does not convey any license under its patent rights nor the rights of others. Freescale Semiconductor products are not designed, intended, or authorized for use as components in systems intended for surgical implant into the body, or other applications intended to support or sustain life, or for any other application in which the failure of the Freescale Semiconductor product could create a situation where personal injury or death may occur. Should Buyer purchase or use Freescale Semiconductor products for any such unintended or unauthorized application, Buyer shall indemnify and hold Freescale Semiconductor and its officers, employees, subsidiaries, affiliates, and distributors harmless against all claims, costs, damages, and expenses, and reasonable attorney fees arising out of, directly or indirectly, any claim of personal injury or death associated with such unintended or unauthorized use, even if such claim alleges that Freescale Semiconductor was negligent regarding the design or manufacture of the part.

RoHS-compliant and/or Pb-free versions of Freescale products have the functionality and electrical characteristics as their non-RoHS-compliant and/or non-Pb-free counterparts. For further information, see <http://www.freescale.com> or contact your Freescale sales representative.

For information on Freescale's Environmental Products program, go to

<http://www.freescale.com/epp>.

Freescale™ and the Freescale logo are trademarks of Freescale Semiconductor, Inc. All other product or service names are the property of their respective owners.
© Freescale Semiconductor, Inc. 2008. All rights reserved.

