



Chipsmall Limited consists of a professional team with an average of over 10 year of expertise in the distribution of electronic components. Based in Hongkong, we have already established firm and mutual-benefit business relationships with customers from,Europe,America and south Asia,supplying obsolete and hard-to-find components to meet their specific needs.

With the principle of “Quality Parts,Customers Priority,Honest Operation,and Considerate Service”,our business mainly focus on the distribution of electronic components. Line cards we deal with include Microchip,ALPS,ROHM,Xilinx,Pulse,ON,Everlight and Freescale. Main products comprise IC,Modules,Potentiometer,IC Socket,Relay,Connector.Our parts cover such applications as commercial,industrial, and automotives areas.

We are looking forward to setting up business relationship with you and hope to provide you with the best service and solution. Let us make a better world for our industry!



Contact us

Tel: +86-755-8981 8866 Fax: +86-755-8427 6832

Email & Skype: info@chipsmall.com Web: www.chipsmall.com

Address: A1208, Overseas Decoration Building, #122 Zhenhua RD., Futian, Shenzhen, China



256 Kbit (32K x8) 3.0V Asynchronous SRAM

FEATURES SUMMARY

- SUPPLY VOLTAGE: 2.7 to 3.6V
- 32K x 8 bits SRAM with OUTPUT ENABLE
- EQUAL CYCLE and ACCESS TIME: 70ns
- LOW STANDBY CURRENT
- LOW V_{CC} DATA RETENTION: 1.5V
- TRI-STATE COMMON I/O
- AUTOMATIC POWER DOWN

Figure 1. Packages

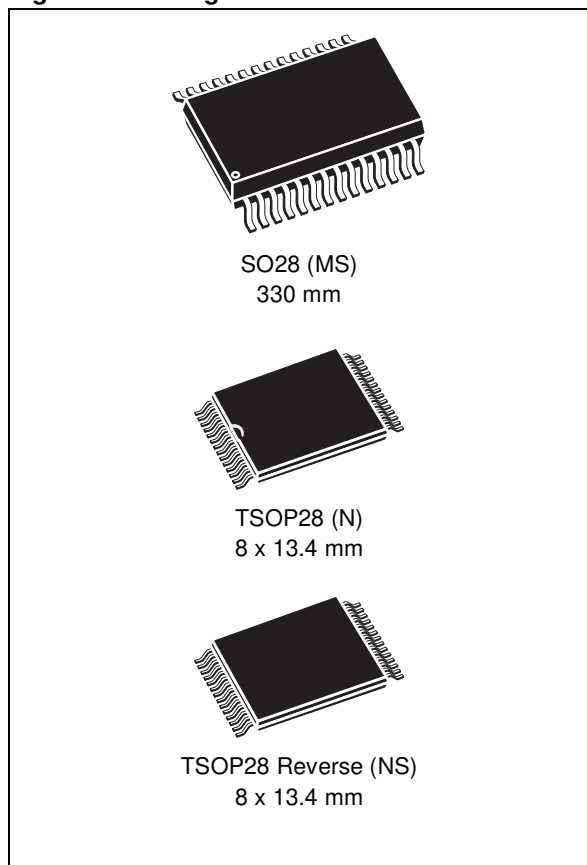

TABLE OF CONTENTS

SUMMARY DESCRIPTION	3
Figure 2. Logic Diagram	3
Table 1. Signal Names	3
Figure 3. SO Connections	4
Figure 4. TSOP Connections (Reverse)	4
Figure 5. TSOP Connections (Normal)	4
Figure 6. Block Diagram	5
OPERATION	6
Table 2. Operating Modes	6
Read Mode	6
Write Mode	6
MAXIMUM RATING	7
Table 3. Absolute Maximum Ratings	7
DC AND AC PARAMETERS	8
Table 4. Operating and AC Measurement Conditions	8
Figure 7. AC Measurement I/O Waveform	8
Figure 8. AC Measurement Load Circuit	8
Table 5. Capacitance	9
Table 6. DC Characteristics	9
Figure 9. Address Controlled, Read Mode AC Waveforms	10
Figure 10. Chip Enable or Output Enable Controlled, Read Mode AC Waveforms	10
Figure 11. Chip Enable Controlled, Standby Mode AC Waveforms	10
Table 7. Read and Standby Mode AC Characteristics	11
Figure 12. Write Enable Controlled, Write AC Waveforms	12
Figure 13. Chip Enable Controlled, Write AC Waveforms	12
Table 8. Write Mode AC Characteristics	13
Figure 14. Low V_{CC} Data Retention AC Waveforms	14
Table 9. Low V_{CC} Data Retention Characteristics	14
PACKAGE MECHANICAL	15
SO28 - 28 lead Plastic Small Outline, 330 mils body width, Package Outline	15
SO28 - 28 lead Plastic Small Outline, 330 mils body width, Package Mechanical Data	15
TSOP28 - 28 lead Normal and Reverse Pinout Plastic Small Outline, Package Outline	16
TSOP28 - 28 lead Normal and Reverse Pinout Plastic Small Outline, Package Mechanical Data	16
PART NUMBERING	17
Table 12. Ordering Information Scheme	17
REVISION HISTORY	18
Table 13. Document Revision History	18

SUMMARY DESCRIPTION

The M68AW031A is a 256 Kbit (262,144 bit) CMOS SRAM, organized as 32,768 bytes by 8 bits. The device features fully static operation requiring no external clocks or timing strobes, with equal address access and cycle times. It requires a single 2.7 to 3.6V supply. This device has an au-

tomatic power-down feature, reducing the power consumption by over 99% when deselected.

The M68AW031A is available in SO28 (28-lead Small Outline) and TSOP28 (28-lead Thin Small Outline, Standard and Reverse Pinout) packages.

Figure 2. Logic Diagram

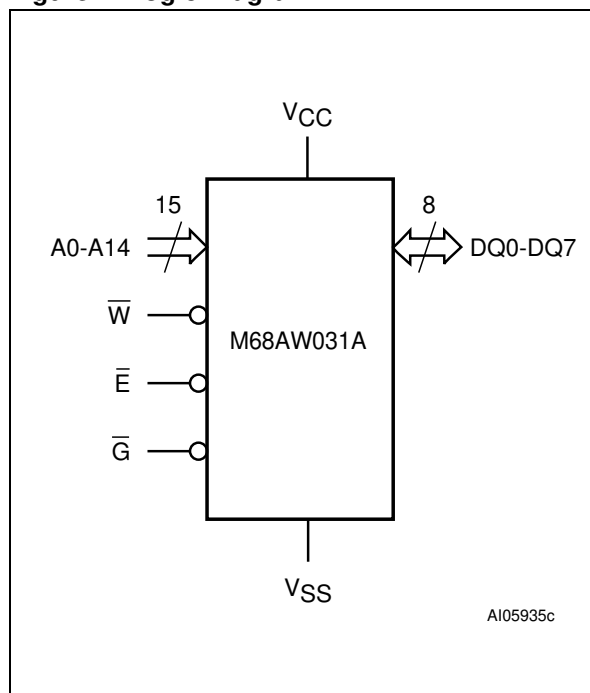

Table 1. Signal Names

A0-A14	Address Inputs
DQ0-DQ7	Data Input/Output
\bar{E}	Chip Enable
\bar{G}	Output Enable
\bar{W}	Write Enable
V _{CC}	Supply Voltage
V _{SS}	Ground

Figure 3. SO Connections

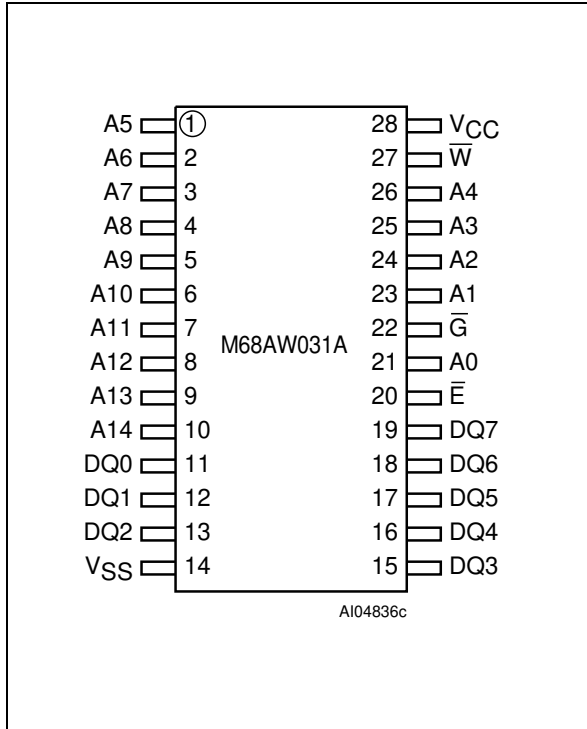

Figure 5. TSOP Connections (Normal)

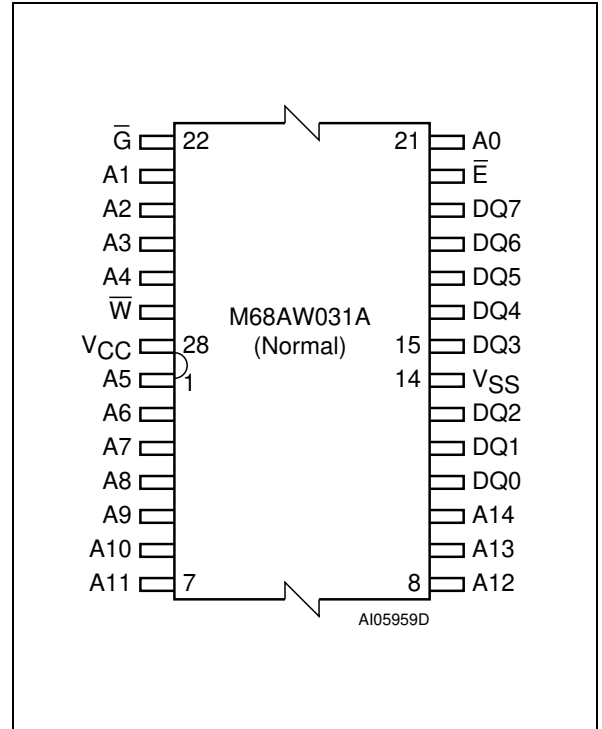

Figure 4. TSOP Connections (Reverse)

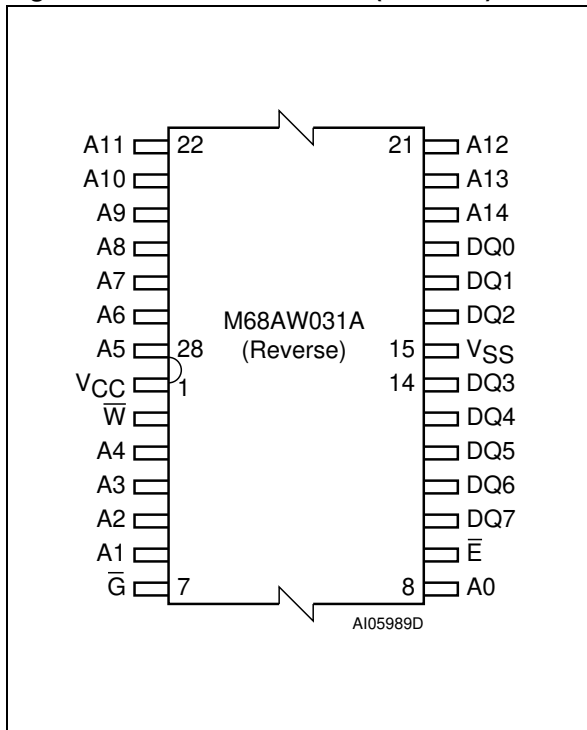
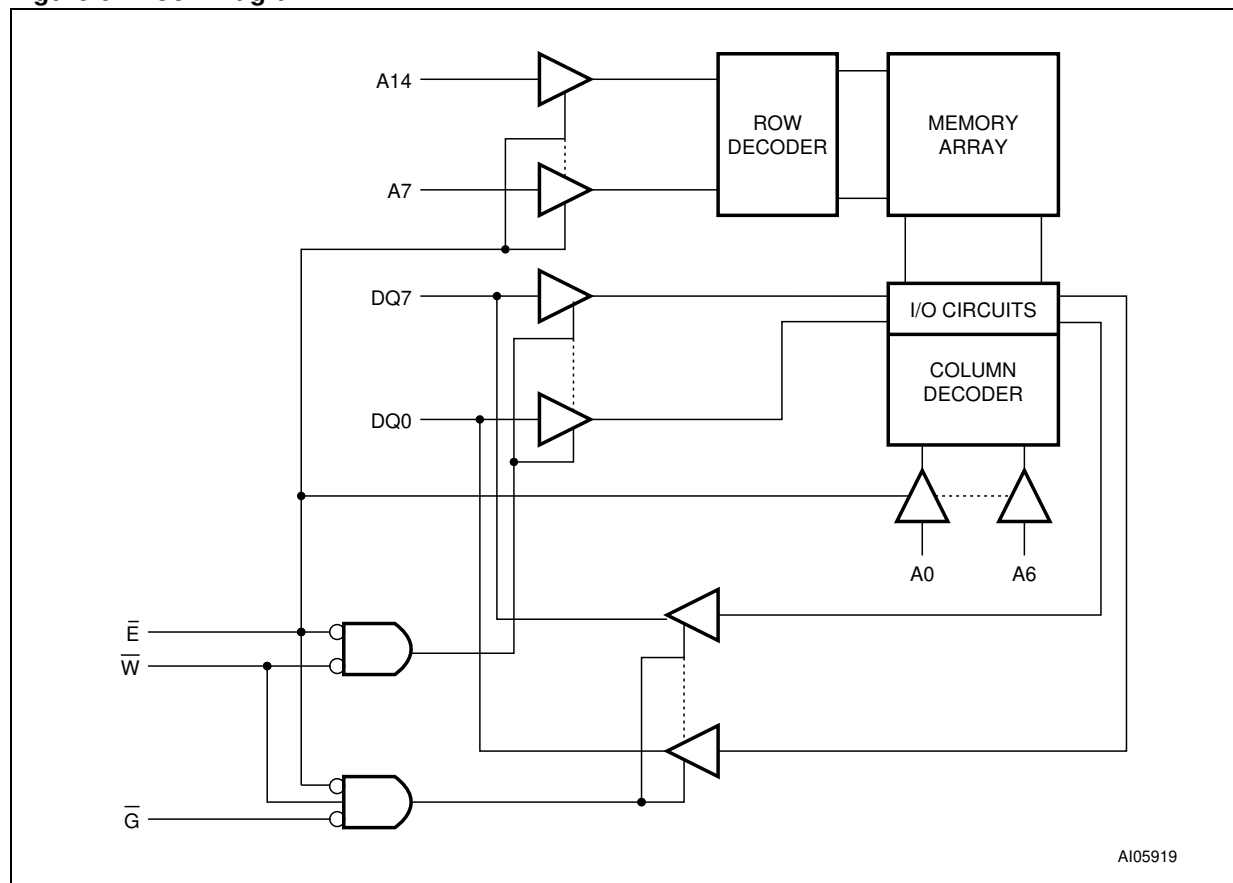

Figure 6. Block Diagram



OPERATION

The M68AW031A has a Chip Enable power down feature which invokes an automatic standby mode whenever Chip Enable is de-asserted (\bar{E} = High). An Output Enable (\bar{G}) signal provides a high speed tri-state control, allowing fast read/write cy-

cles to be achieved with the common I/O data bus. Operational modes are determined by device control inputs \bar{W} and \bar{E} as summarized in the Operating Modes table (see Table 2).

Table 2. Operating Modes

Operation	\bar{E}	\bar{W}	\bar{G}	DQ0-DQ7	Power
Deselected	V_{IH}	X	X	Hi-Z	Standby (I_{SB})
Read	V_{IL}	V_{IH}	V_{IL}	Data Output	Active (I_{CC})
Write	V_{IL}	V_{IL}	X	Data Input	Active (I_{CC})
Output Disabled	V_{IL}	V_{IH}	V_{IH}	Hi-Z	Active (I_{CC})

Note: X = V_{IH} or V_{IL} .

Read Mode

The M68AW031A is in the Read mode whenever Write Enable (\bar{W}) is High with Output Enable (\bar{G}) Low, and Chip Enable (\bar{E}) is asserted. This provides access to data of the 262,144 locations in the static memory array, specified by the 15 address inputs. Valid data will be available at the eight output pins within t_{AVQV} after the last stable address, providing \bar{G} is Low and \bar{E} is Low. If Chip Enable or Output Enable access times are not met, data access will be measured from the limiting parameter (t_{ELQV} or t_{GLQV}) rather than the address. Data out may be indeterminate at t_{ELQX} and t_{GLQX} but data lines will always be valid at t_{AVQV} . See Figures 9, 10, 11 and Table 7 for details on Read mode AC timings and Characteristics.

Write Mode

The M68AW031A is in the Write mode whenever the \bar{W} and \bar{E} are Low. Either the Chip Enable input (\bar{E}) or the Write Enable input (\bar{W}) must be de-

asserted during Address transitions for subsequent write cycles. When \bar{E} (\bar{W}) is Low, write cycle begins on the \bar{W} (\bar{E})'s falling edge. Therefore, address setup time is referenced to Write Enable or Chip Enable as t_{AVWL} and t_{AVEL} respectively, and is determined by the latter occurring edge.

The Write cycle can be terminated by the earlier rising edge of \bar{E} or \bar{W} .

If the Output is enabled (\bar{E} = Low, \bar{G} = Low), then \bar{W} will return the outputs to high impedance within t_{WLQZ} of its falling edge. Care must be taken to avoid bus contention in this type of operation. Data input must be valid for t_{DVWH} before the rising edge of Write Enable, or for t_{DVEH} before the rising edge of \bar{E} , whichever occurs first, and remain valid for t_{WHDX} and t_{EHDX} respectively.

See Figures 12, 10 and Table 8 for details on Write mode AC timings and Characteristics.

MAXIMUM RATING

Stressing the device above the rating listed in the Absolute Maximum Ratings table may cause permanent damage to the device. These are stress ratings only and operation of the device at these or any other conditions above those indicated in the Operating sections of this specification is not im-

plied. Exposure to Absolute Maximum Rating conditions for periods greater than 1s periods may affect device reliability. Refer also to the STMicroelectronics SURE Program and other relevant quality documents.

Table 3. Absolute Maximum Ratings

Symbol	Parameter	Value	Unit
$I_O^{(1)}$	Output Current	20	mA
T_A	Ambient Operating Temperature	-55 to 125	°C
T_{STG}	Storage Temperature	-65 to 150	°C
T_{LEAD}	Lead Temperature during Soldering ⁽²⁾	260 ⁽³⁾	°C
V_{CC}	Supply Voltage	-0.5 to 4.6	V
$V_{IO}^{(4)}$	Input or Output Voltage	-0.5 to $V_{CC} + 0.5$	V
P_D	Power Dissipation	1	W

Note: 1. One output at time not to exceed 1 second duration.

2. Compliant with the ECOPACK[®] 7191395 specification for Lead-free soldering processes.

3. Not exceeding 250°C for more than 30s, and peaking at 260°C.

4. Up to a maximum operating V_{CC} of 3.6V only.

DC AND AC PARAMETERS

This section summarizes the operating and measurement conditions, as well as the DC and AC characteristics of the device. The parameters in the following DC and AC Characteristic tables are derived from tests performed under the Measure-

ment Conditions listed in the relevant tables. Designers should check that the operating conditions in their projects match the measurement conditions when using the quoted parameters.

Table 4. Operating and AC Measurement Conditions

Parameter		M68AW031A
V _{CC} Supply Voltage		2.7 to 3.6V
Ambient Operating Temperature	Range 1	0 to 70°C
	Range 6	-40 to 85°C
Load Capacitance (C _L)		30pF
Output Circuit Protection Resistance (R ₁)		3.0kΩ
Load Resistance (R ₂)		3.1kΩ
Input Rise and Fall Times		1ns/V
Input Pulse Voltages		0 to V _{CC}
Input and Output Timing Ref. Voltages		V _{CC} /2
Output Transition Timing Ref. Voltages		V _{RL} = 0.3V _{CC} ; V _{RH} = 0.7V _{CC}

Figure 7. AC Measurement I/O Waveform

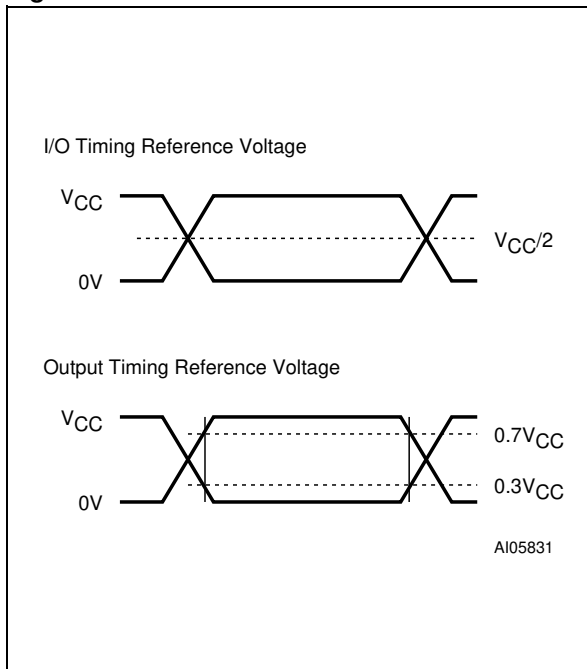

Figure 8. AC Measurement Load Circuit

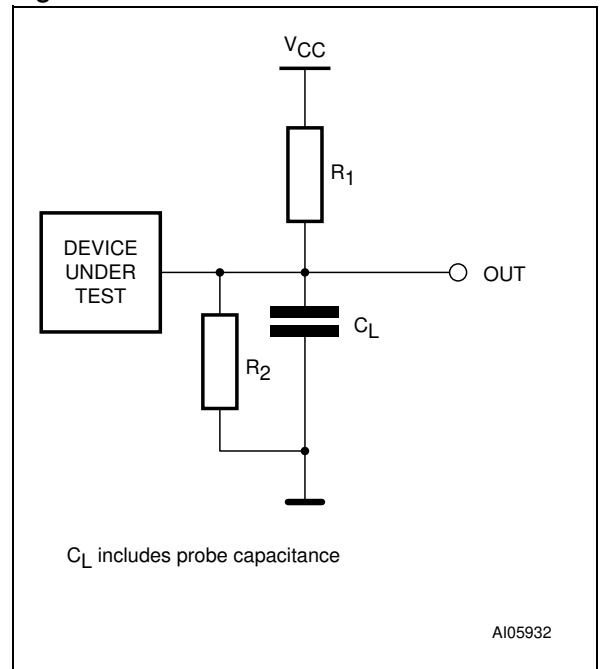

Table 5. Capacitance

Symbol	Parameter ^(1,2)	Test Condition	Min	Max	Unit
C _{IN}	Input Capacitance on all pins (except DQ)	V _{IN} = 0V		6	pF
C _{OUT}	Output Capacitance	V _{OUT} = 0V		8	pF

Note: 1. Sampled only, not 100% tested.

2. At T_A = 25°C, f = 1 MHz, V_{CC} = 3.0V.

Table 6. DC Characteristics

Symbol	Parameter	Test Condition	Min	Typ	Max	Unit
I _{CC1} ^(1,2)	Operating Supply Current	V _{CC} = 3.6V, f = 1/t _{AVAV} , I _{OUT} = 0mA			30	mA
I _{CC2} ⁽³⁾	Operating Supply Current	V _{CC} = 3.6V, f = 1MHz, I _{OUT} = 0mA		2	5	mA
I _{SB}	Standby Supply Current CMOS	V _{CC} = 3.6V, f = 0, E ≥ V _{CC} - 0.2V or V _{IN} = 0.2V or V _{IN} = V _{CC} - 0.2V		4	10	μA
I _{LI}	Input Leakage Current	0V ≤ V _{IN} ≤ V _{CC}	-1		1	μA
I _{LO} ⁽⁴⁾	Output Leakage Current	0V ≤ V _{OUT} ≤ V _{CC}	-1		1	μA
V _{IH}	Input High Voltage		2.2		V _{CC} + 0.3	V
V _{IL}	Input Low Voltage		-0.3		0.6	V
V _{OH}	Output High Voltage	I _{OH} = -1.0mA	2.4			V
V _{OL}	Output Low Voltage	I _{OL} = 2.1mA			0.4	V

Note: 1. Average AC current, cycling at t_{AVAV} minimum.

2. E = V_{IL}, V_{IN} = V_{IL} or V_{IH}.

3. E ≤ 0.2V, V_{IN} ≤ 0.2V or V_{IN} ≥ V_{CC} - 0.2V.

4. Output disabled.

Figure 9. Address Controlled, Read Mode AC Waveforms

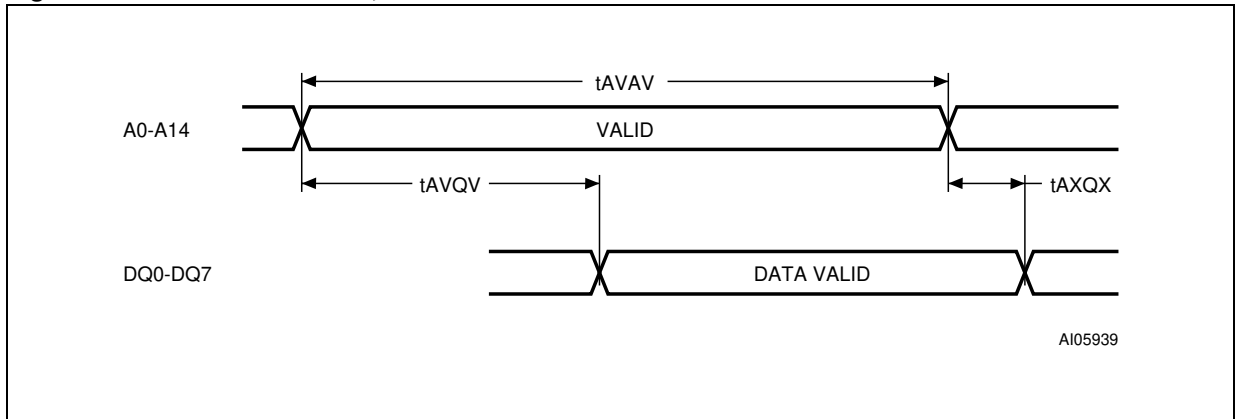

Note: \bar{E} = Low, \bar{G} = Low, \bar{W} = High.

Figure 10. Chip Enable or Output Enable Controlled, Read Mode AC Waveforms.

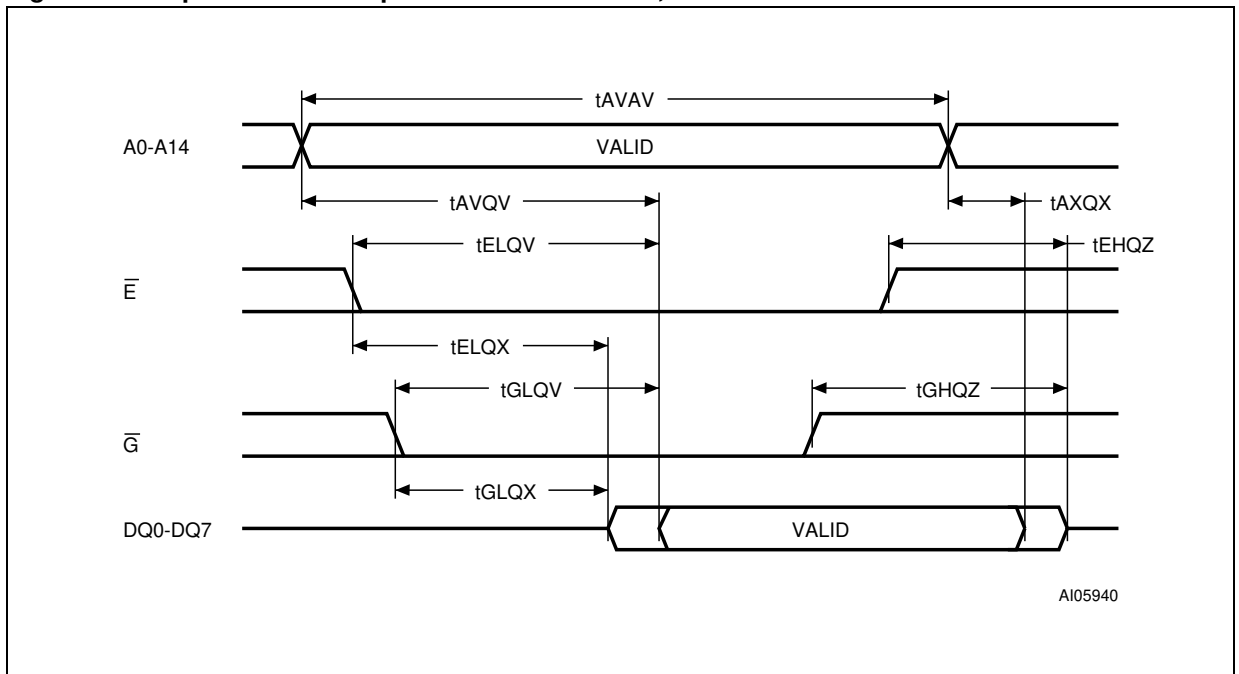

Note: Write Enable (\bar{W}) = High.

Figure 11. Chip Enable Controlled, Standby Mode AC Waveforms

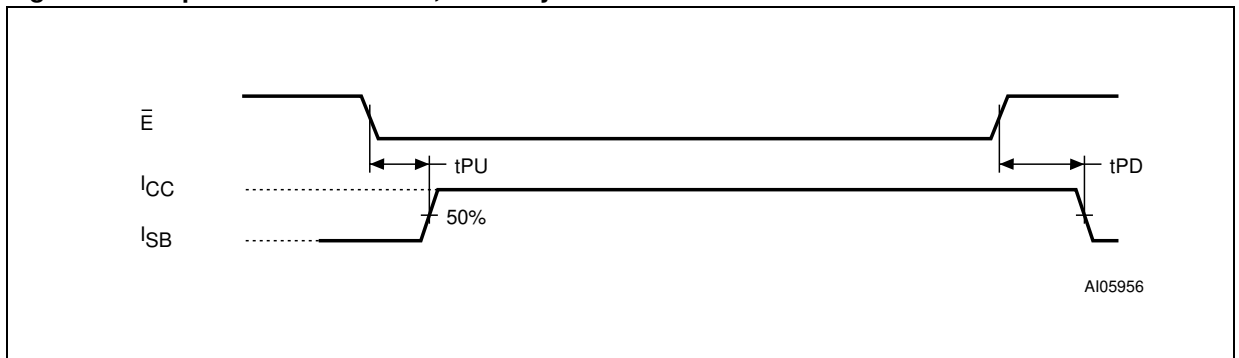

Table 7. Read and Standby Mode AC Characteristics

Symbol	Parameter		M68AW031A	Unit
			70	
t_{AVAV}	Read Cycle Time	Min	70	ns
t_{AVQV}	Address Valid to Output Valid	Max	70	ns
$t_{AXQX}^{(1)}$	Data hold from address change	Min	10	ns
$t_{EHQZ}^{(2,3)}$	Chip Enable High to Output Hi-Z	Max	25	ns
t_{ELQV}	Chip Enable Low to Output Valid	Max	70	ns
$t_{ELQX}^{(1)}$	Chip Enable Low to Output Transition	Min	10	ns
$t_{GHQZ}^{(2,3)}$	Output Enable High to Output Hi-Z	Max	25	ns
t_{GLQV}	Output Enable Low to Output Valid	Max	35	ns
$t_{GLQX}^{(1)}$	Output Enable Low to Output Transition	Min	5	ns
$t_{PD}^{(4)}$	Chip Enable High to Power Down	Max	70	ns
$t_{PU}^{(4)}$	Chip Enable Low to Power Up	Min	0	ns

Note: 1. Test conditions assume transition timing reference level = $0.3V_{CC}$ or $0.7V_{CC}$.

2. At any given temperature and voltage condition, t_{GHQZ} is less than t_{GLQX} and t_{EHQZ} is less than t_{ELQX} for any given device.

3. These parameters are defined as the time at which the outputs achieve the open circuit conditions and are not referenced to output voltage levels.

4. Tested initially and after any design or process changes that may affect these parameters.

Figure 12. Write Enable Controlled, Write AC Waveforms

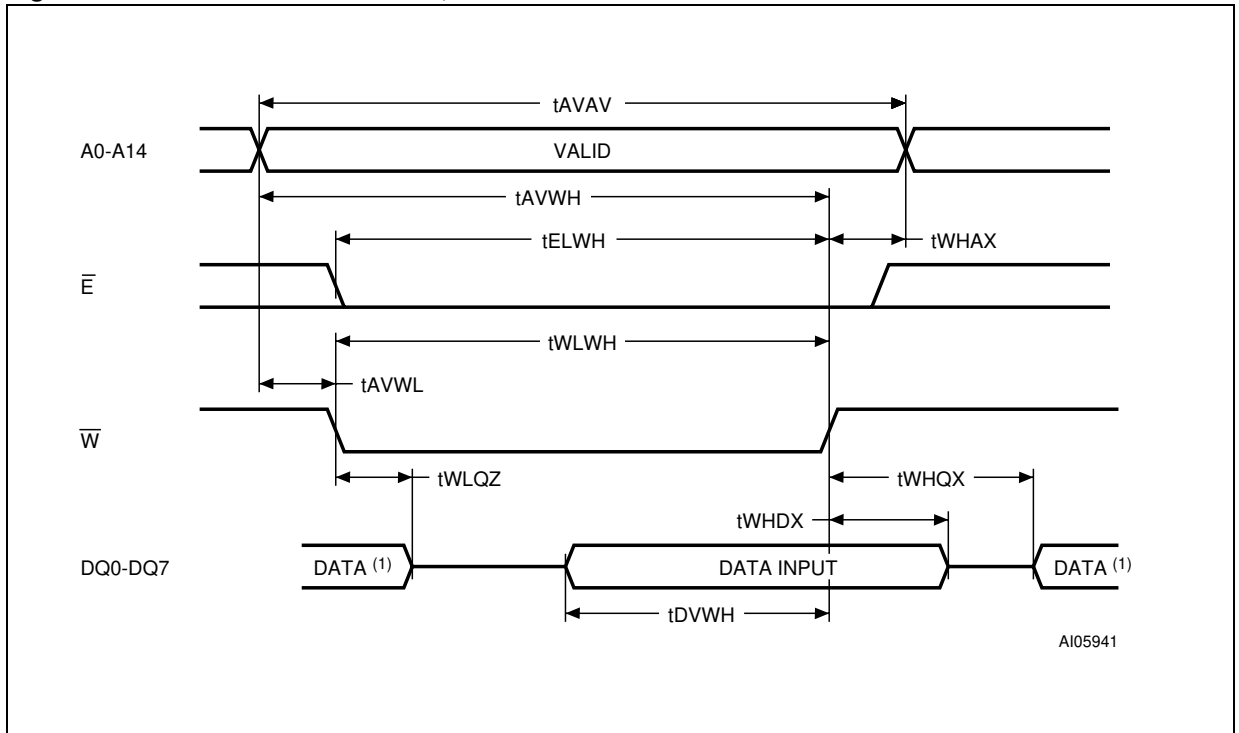

Note: 1. During this period DQ0-DQ7 are in output state and input signals should not be applied.

Figure 13. Chip Enable Controlled, Write AC Waveforms

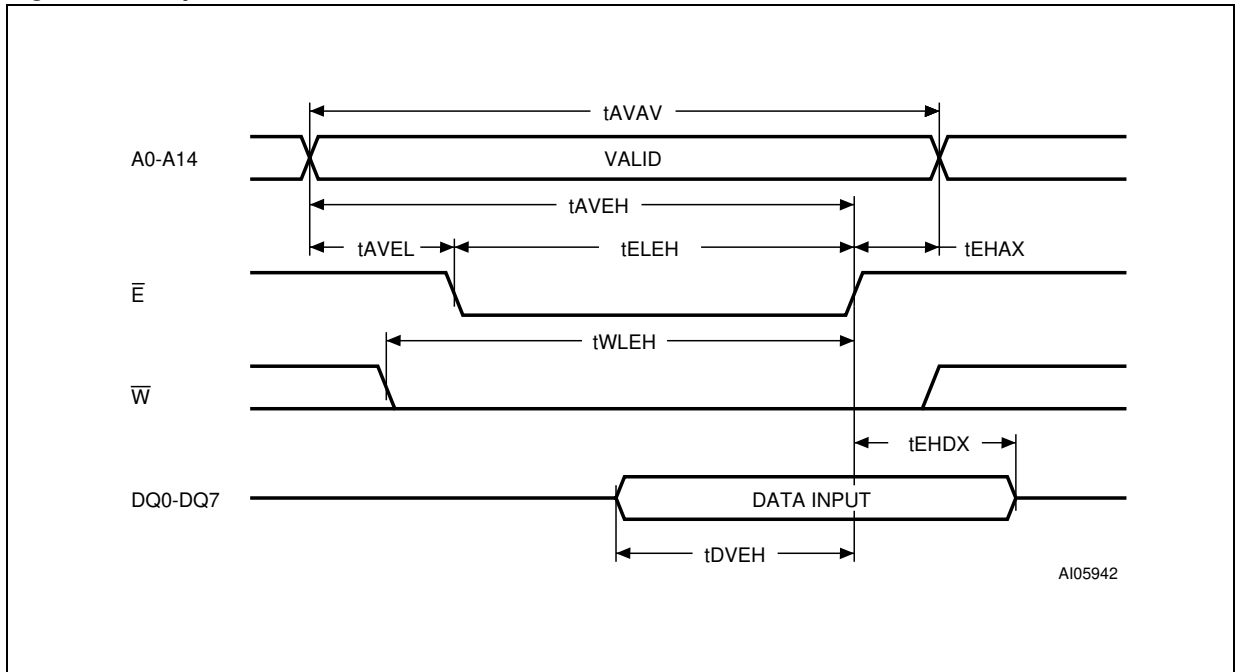
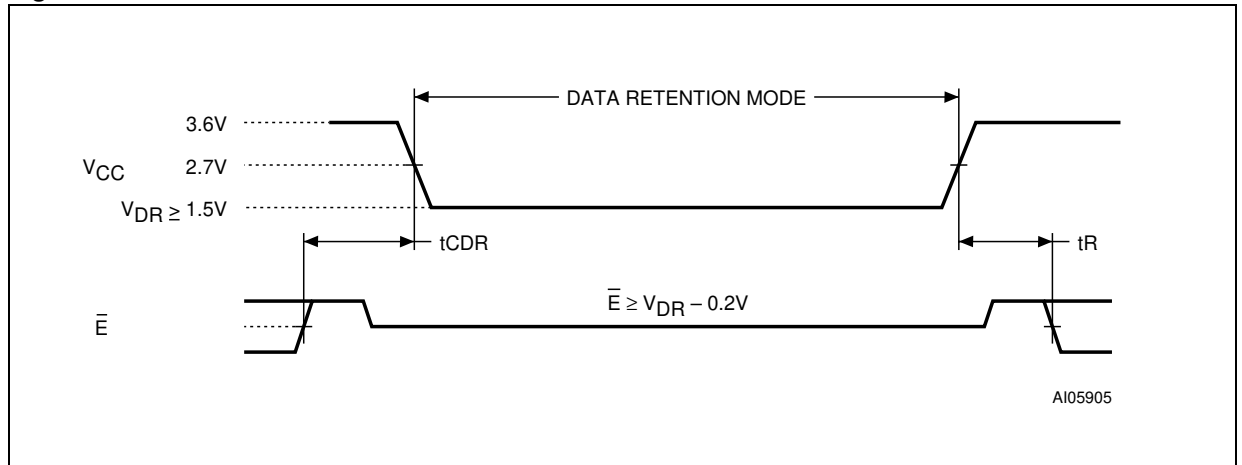

Table 8. Write Mode AC Characteristics

Symbol	Parameter		M68AW031A	Unit
			70	
t_{AVAV}	Write Cycle Time	Min	70	ns
t_{AVEH}	Address Valid to Chip Enable High	Min	60	ns
t_{AVEL}	Address valid to Chip Enable Low	Min	0	ns
t_{AVWH}	Address Valid to Write Enable High	Min	60	ns
t_{AVWL}	Address Valid to Write Enable Low	Min	0	ns
t_{DVEH}	Input Valid to Chip Enable High	Min	30	ns
t_{DVWH}	Input Valid to Write Enable High	Min	30	ns
t_{EHAX}	Chip Enable High to Address Transition	Min	0	ns
t_{EHDX}	Chip enable High to Input Transition	Min	0	ns
t_{ELEH}	Chip Enable Low to Chip Enable High	Min	60	ns
t_{ELWH}	Chip Enable Low to Write Enable High	Min	60	ns
t_{WHAX}	Write Enable High to Address Transition	Min	0	ns
t_{WHDX}	Write Enable High to Input Transition	Min	0	ns
$t_{WHQX}^{(1)}$	Write Enable High to Output Transition	Min	5	ns
t_{WLEH}	Write Enable Low to Chip Enable High	Min	60	ns
$t_{WLQZ}^{(1,2)}$	Write Enable Low to Output Hi-Z	Max	25	ns
t_{WLWH}	Write Enable Low to Write Enable High	Min	60	ns

Note: 1. At any given temperature and voltage condition, t_{WLQZ} is less than t_{WHQX} for any given device.

2. These parameters are defined as the time at which the outputs achieve the open circuit conditions and are not referenced to output voltage levels.

Figure 14. Low V_{CC} Data Retention AC WaveformsTable 9. Low V_{CC} Data Retention Characteristics

Symbol	Parameter	Test Condition	Min	Typ	Max	Unit
$I_{CCDR}^{(1)}$	Supply Current (Data Retention)	$V_{CC} = 1.5V, \bar{E} \geq V_{CC} - 0.2V, f = 0^{(3)}$			6	μA
$t_{CDR}^{(1,2)}$	Chip Deselected to Data Retention Time		0			ns
$t_R^{(2)}$	Operation Recovery Time		t_{AVAV}			ns
$V_{DR}^{(1)}$	Supply Voltage (Data Retention)	$\bar{E} \geq V_{CC} - 0.2V, f = 0$	1.5			V

Note: 1. All other Inputs at $V_{IH} \geq V_{CC} - 0.2V$ or $V_{IL} \leq 0.2V$.

2. Tested initially and after any design or process changes that may affect these parameters. t_{AVAV} is Read cycle time.

3. No input may exceed $V_{CC} + 0.2V$.

PACKAGE MECHANICAL

Figure 15. SO28 - 28 lead Plastic Small Outline, 330 mils body width, Package Outline

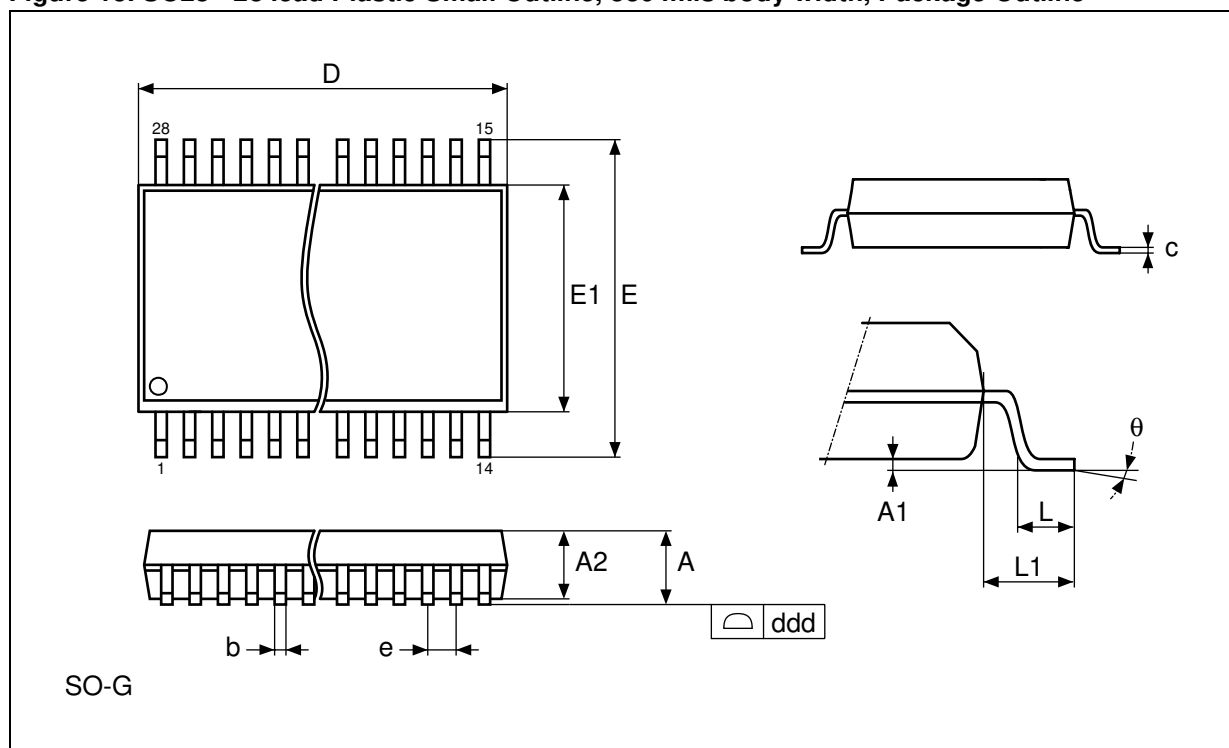

Note: Drawing is not to scale.

Table 10. SO28 - 28 lead Plastic Small Outline, 330 mils body width, Package Mechanical Data

Symbol	millimeters			inches		
	Typ	Min	Max	Typ	Min	Max
A			2.850			0.1122
A1		0.100			0.0039	
A2	2.489	2.362	2.620	0.0980	0.0930	0.1031
b	0.406			0.0160		
c		0.200	0.360		0.0079	0.0142
D	18.110		18.618	0.7130		0.7330
E	11.811		12.116	0.4650		0.4770
E1	8.407			0.3310		
e	1.270	–	–	0.0500	–	–
L	0.914	0.711	1.117	0.0360	0.0280	0.0440
L1	1.702	1.499	1.905	0.0670	0.0590	0.0750
Q		0	10		0	10

Figure 16. TSOP28 - 28 lead Normal and Reverse Pinout Plastic Small Outline, Package Outline

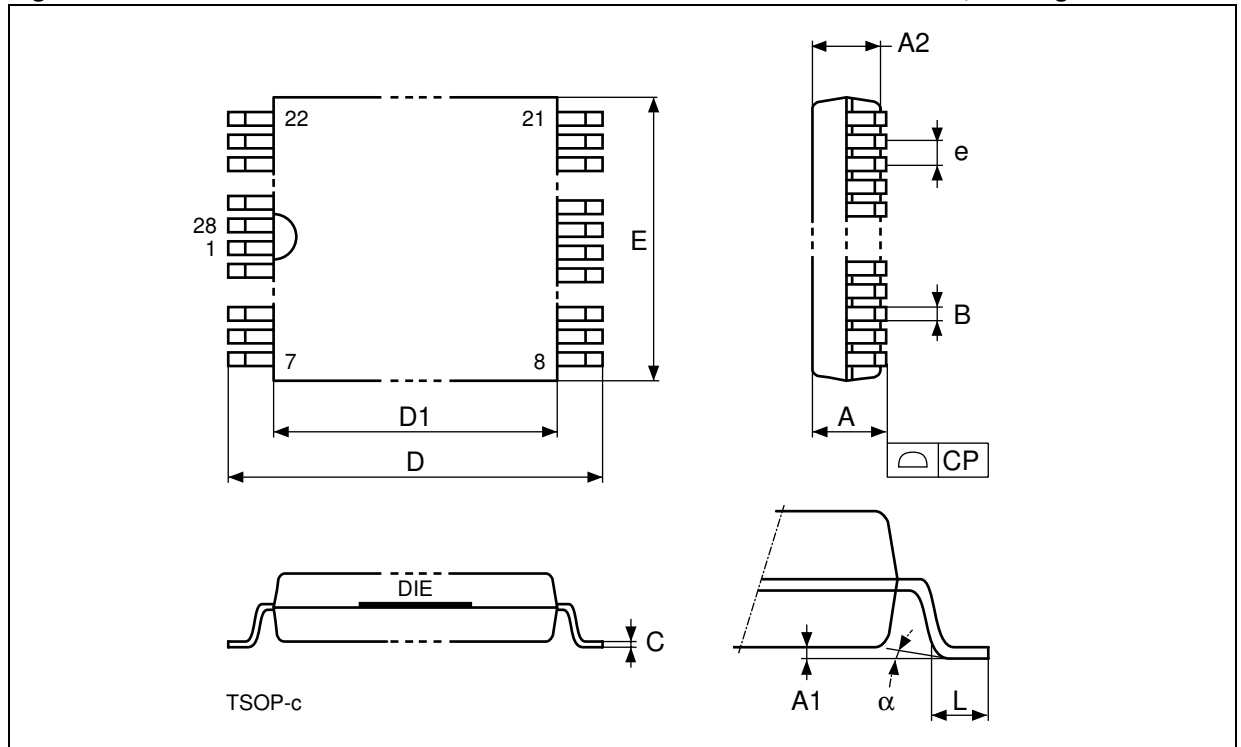

Note: Drawing is not to scale.

Table 11. TSOP28 - 28 lead Normal and Reverse Pinout Plastic Small Outline, Package Mechanical Data

Symbol	millimeters			inches		
	Typ	Min	Max	Typ	Min	Max
A			1.250			0.0492
A1			0.200			0.0079
A2		0.950	1.150		0.0374	0.0453
B		0.170	0.270		0.0067	0.0106
C		0.100	0.210		0.0039	0.0083
CP			0.100			0.0039
D		13.200	13.600		0.5197	0.5354
D1		11.700	11.900		0.4606	0.4685
E		7.900	8.100		0.3110	0.3189
e	0.550	–	–	0.0217	–	–
L		0.500	0.700		0.0197	0.0276
α		0°	5°		0°	5°
N		28			28	

PART NUMBERING

Table 12. Ordering Information Scheme

Example:	M68AW031	A	L	70	MS	6	U
Device Type M68							
Mode A = Asynchronous							
Operating Voltage W = 2.7 to 3.6V							
Array Organization 031 = 256 Kbit (32K x8)							
Option 1 A = 1 Chip Enable							
Option 2 L = L-Die M = M-Die							
Speed Class 70 = 70 ns							
Package MS = SO28 N = TSOP28 8x13.4mm NS = TSOP28 8x13.4mm (Reverse Pinout)							
Operative Temperature 6 = -40 to 85 °C 1 = 0 to 70 °C							
Shipping U = Tube T = Tape and Reel							

For a list of available options (Speed, Package, etc...) or for further information on any aspect of this device, please contact the STMicroelectronics Sales Office nearest to you.

REVISION HISTORY

Table 13. Document Revision History

Date	Version	Revision Details
January 2002	1.0	First Issue
07-Feb-2002	2.0	TSOP28 Package Order Code clarified
08-Feb-2002	3.0	AC Measurement Load Circuit clarified (Figure 8)
06-Mar-2002	4.0	Document status changed to Data Sheet
20-May-2002	5.0	Absolute Maximum Ratings table clarified (Table 3) Operating and AC Measurement Conditions table clarified (Table 4) DC Characteristics table clarified (Table 6) Low V_{CC} Data Retention AC Waveforms and Characteristics table clarified (Figure 14, Table 4)
01-Jun-2002	6.0	TSOP28 8x13.4mm Standard pinout added (Figure 5, Table 12) Block Diagram clarified (Figure 6) T_A clarified in Absolute Maximum Ratings (Table 3) Operating and AC Measurement Conditions table clarified (Table 4) I_{CC2} Max added in DC Characteristics (Table 6) t_{PD} , t_{PU} clarified in Read and Standby Mode AC Characteristics (Table 7) t_{WLEH} , t_{WLWH} clarified in Write Mode AC Characteristics (Table 8)
09-Sep-2002	6.1	Load Capacitance (C_L) changed from 100pF to 30pF (Table 4)
02-Oct-2002	6.2	New part number added.
09-Oct-2002	6.3	Part number modified.
22-May-2003	6.4	Temperature range 1 added to Ordering Information Scheme. TSOP pin numbering corrected
02-Jul-2003	6.5	Value of $I_{SB}(typ)$ changed in DC Characteristics table
25-Nov-2003	6.6	SO28 package modified. Part numbering scheme updated. TLEAD parameter added in Table 3, Absolute Maximum Ratings. AC, DC Characteristics and waveforms grouped together. t_{PD} maximum value and t_{PU} minimum value updated in Table 7, Read and Standby Mode AC Characteristics.

Information furnished is believed to be accurate and reliable. However, STMicroelectronics assumes no responsibility for the consequences of use of such information nor for any infringement of patents or other rights of third parties which may result from its use. No license is granted by implication or otherwise under any patent or patent rights of STMicroelectronics. Specifications mentioned in this publication are subject to change without notice. This publication supersedes and replaces all information previously supplied. STMicroelectronics products are not authorized for use as critical components in life support devices or systems without express written approval of STMicroelectronics.

The ST logo is a registered trademark of STMicroelectronics.

All other names are the property of their respective owners

© 2003 STMicroelectronics - All rights reserved

STMicroelectronics GROUP OF COMPANIES

Australia - Belgium - Brazil - Canada - China - Czech Republic - Finland - France - Germany - Hong Kong - India - Israel - Italy - Japan - Malaysia - Malta - Morocco - Singapore - Spain - Sweden - Switzerland - United Kingdom - United States

www.st.com