



Chipsmall Limited consists of a professional team with an average of over 10 year of expertise in the distribution of electronic components. Based in Hongkong, we have already established firm and mutual-benefit business relationships with customers from,Europe,America and south Asia,supplying obsolete and hard-to-find components to meet their specific needs.

With the principle of “Quality Parts,Customers Priority,Honest Operation,and Considerate Service”,our business mainly focus on the distribution of electronic components. Line cards we deal with include Microchip,ALPS,ROHM,Xilinx,Pulse,ON,Everlight and Freescale. Main products comprise IC,Modules,Potentiometer,IC Socket,Relay,Connector.Our parts cover such applications as commercial,industrial, and automotives areas.

We are looking forward to setting up business relationship with you and hope to provide you with the best service and solution. Let us make a better world for our industry!



Contact us

Tel: +86-755-8981 8866 Fax: +86-755-8427 6832

Email & Skype: info@chipsmall.com Web: www.chipsmall.com

Address: A1208, Overseas Decoration Building, #122 Zhenhua RD., Futian, Shenzhen, China



Features

- Low power dissipation:
 - $I_{CC} = 4 \mu\text{A}(\text{max})$ at $T_A = 25 \text{ }^\circ\text{C}$
- Logic level translation to enable 5 V logic signal to communicate with $\pm 5 \text{ V}$ analog signal
- Low ON resistance:
 - 70 Ω typ ($V_{CC} - V_{EE} = 4.5 \text{ V}$)
 - 50 Ω typ ($V_{CC} - V_{EE} = 9 \text{ V}$)
- Wide analog input voltage range : $\pm 6 \text{ V}$
- Fast switching:
 - $t_{pd} = 15 \text{ ns (typ)}$ at $T_A = 25 \text{ }^\circ\text{C}$
- Low crosstalk between switches
- High ON/OFF output voltage ratio
- Wide operating supply voltage range ($V_{CC} - V_{EE}$) = 2 to 12 V
- Low sine wave distortion: 0.02% at $V_{CC} - V_{EE} = 9 \text{ V}$
- High noise immunity:
 - $V_{NIH} = V_{NIL} = 28 \% V_{CC} (\text{min})$
- Pin and function compatible with 74 series 4051

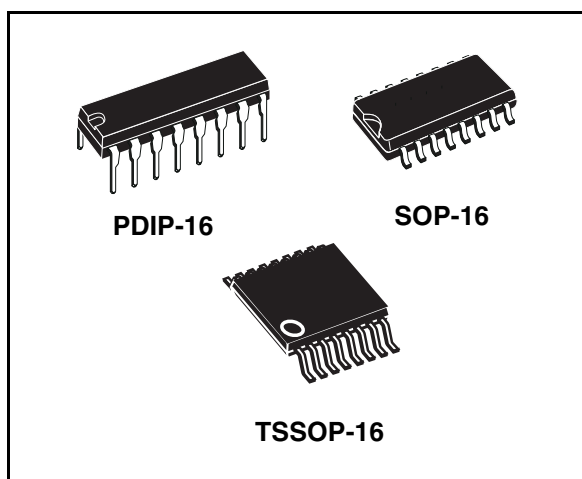

Description

The M74HC4051 is a single 8-channel analog multiplexer/demultiplexer fabricated with silicon gate C^2 MOS technology, pin-to-pin compatible with the equivalent metal gate CMOS4000B series. It contains 8 bidirectional and digitally controlled analog switches.

A built-in level shifting is included to allow an input range up to $\pm 6 \text{ V}$ (peak) for an analog signal with digital control signal of 0 to 6 V.

The V_{EE} supply pin is provided for analog input signals. It has an inhibit (INH) input terminal to disable all the switches when is at high level. For operation as a digital multiplexer/demultiplexer, V_{EE} is connected to GND.

A, B and C control inputs select one channel out of eight. All inputs are equipped with protection circuits against static discharge and transient excess voltage.

Table 1. Device summary

Order code	Package	Packaging
M74HC4051RM13TR	SOP-16	Tape and reel
M74HC4051TTR	TSSOP-16	Tape and reel

1 Pin connection and IEC logic symbols

Figure 1. Pin connection

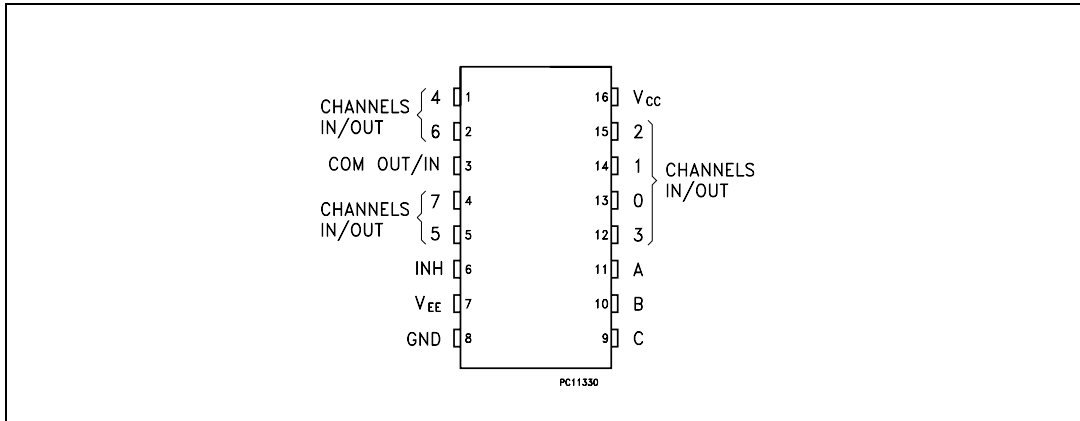
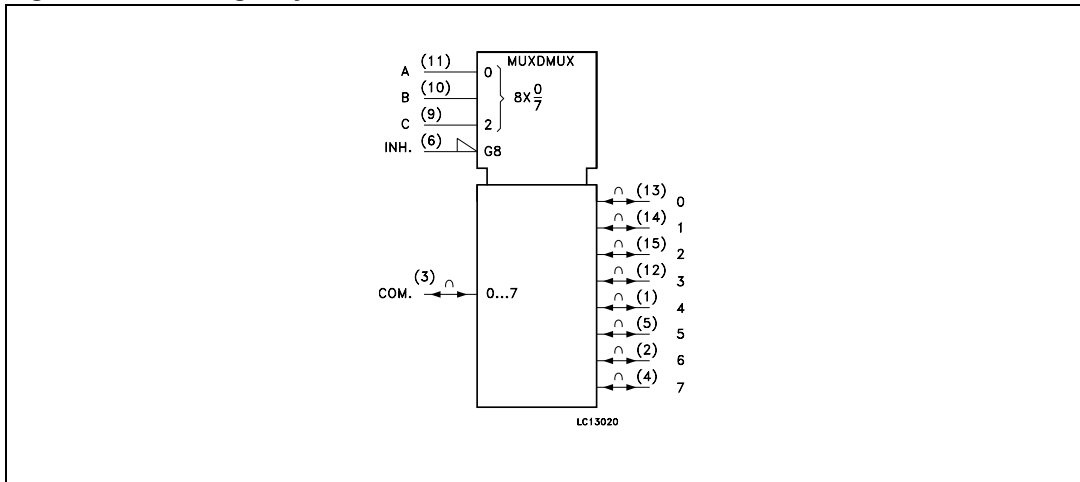

Figure 2. IEC logic symbols



1.1 Pin description

Table 2. Pin description

Pin number	Symbol	Name and function
3	COM OUT/IN	Common output/input
6	INH	Inhibit input
7	V _{EE}	Negative supply voltage
11, 10, 9	A, B, C	Select inputs
13, 14, 15, 12, 1, 5, 2, 4	0 to 7	Independent input/outputs
8	GND	Ground (0 V)
16	V _{CC}	Positive supply voltage

Figure 3. Control input equivalent circuit

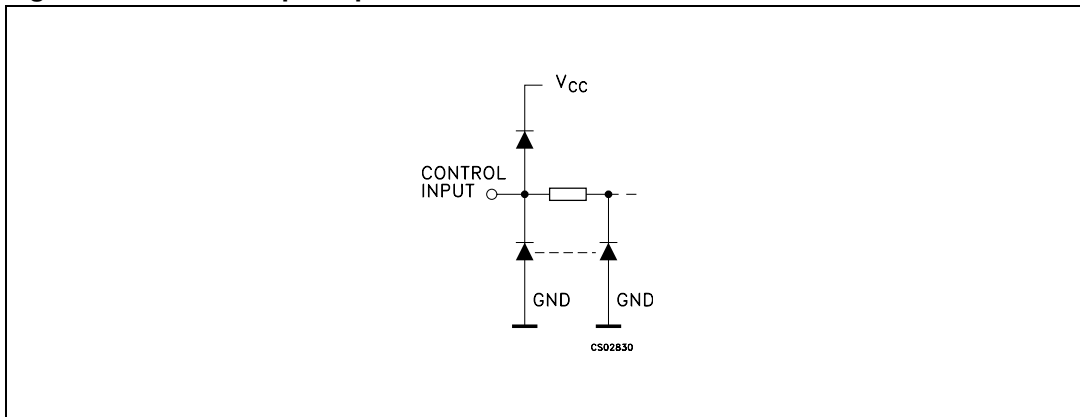

Figure 4. I/O equivalent circuit

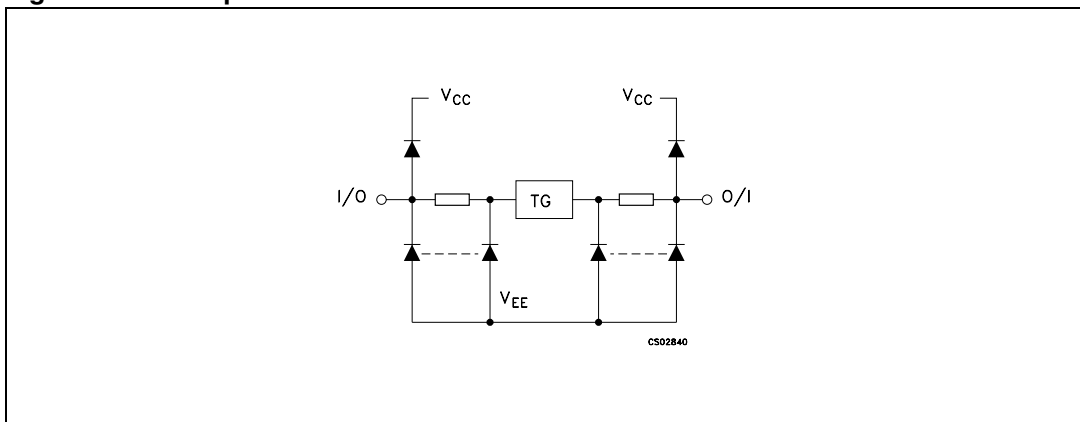

Table 3. Truth table

Input state				ON channel
INH	C	B	A	
L	L	L	L	0
L	L	L	H	1
L	L	H	L	2
L	L	H	H	3
L	H	L	L	4
L	H	L	H	5
L	H	H	L	6
L	H	H	H	7
H	X	X	X	NONE

x: Don't care

2 Maximum ratings

Stressing the device above the rating listed in the “absolute maximum ratings” table may cause permanent damage to the device. These are stress ratings only and operation of the device at these or any other conditions above those indicated in the operating sections of this specification is not implied. Exposure to absolute maximum rating conditions for extended periods may affect device reliability. Refer also to the STMicroelectronics SURE Program and other relevant quality documents.

Table 4. Absolute maximum ratings

Symbol	Parameter		Value	Unit
V_{CC}	Supply voltage		-0.5 to +7	V
$V_{CC} - V_{EE}$	Supply voltage		-0.5 to +13	V
V_I	Control input voltage		-0.5 to $V_{CC} + 0.5$	V
$V_{I/O}$	Switch I/O voltage		$V_{EE} - 0.5$ to $V_{CC} + 0.5$	V
I_{CK}	Control input diode current		±20	mA
I_{IOK}	I/O diode current		±20	mA
I_T	Switch through current		±25	mA
I_{CC} or I_{GND}	DC V_{CC} or ground current		±50	mA
P_D	Power dissipation	DIP-16	500 ⁽¹⁾	mW
		SOP-16 and TSSOP-16	180	mW
T_{stg}	Storage temperature		-65 to +150	°C
T_L	Lead temperature (10 sec)		300	°C

1. 500 mW at 65 °C; derate to 300 mW by 10 mW/°C from 65 °C to 85 °C

Table 5. Recommended operating conditions

Symbol	Parameter		Value	Unit
V_{CC}	Supply voltage		2 to 6	V
V_{EE}	Supply voltage		-6 to 0	V
$V_{CC} - V_{EE}$	Supply voltage		2 to 12	V
V_I	Input voltage		0 to V_{CC}	V
$V_{I/O}$	I/O voltage		V_{EE} to V_{CC}	V
T_{op}	Operating temperature		-55 to 125	°C
t_r, t_f	Input rise and fall time	$V_{CC} = 2.0$ V	0 to 1000	ns
		$V_{CC} = 4.5$ V	0 to 500	
		$V_{CC} = 6.0$ V	0 to 400	

Table 6. DC electrical specifications

Symbol	Parameter	Test condition			Value						Unit	
		V _{CC} (V)	V _{EE} (V)		T _A = 25 °C			-40 to 85 °C		-55 to 125 °C		
					Min	Typ	Max	Min	Max	Min		Max
V _{IHC}	High level input voltage	2.0			1.5			1.5		1.5		V
		4.5			3.15			3.15		3.15		
		6.0			4.2			4.2		4.2		
V _{ILC}	Low level input voltage	2.0					0.5		0.5		0.5	V
		4.5					1.35		1.35		1.35	
		6.0					1.8		1.8		1.8	
R _{ON}	ON resistance	4.5	GND	V _I = V _{IHC} or V _{ILC} V _{I/O} = V _{CC} to V _{EE} I _{I/O} ≤ 2mA		85	180		225		270	W
		4.5	-4.5			55	120		150		180	
		6.0	-6.0			50	100		125		150	
		2.0	GND	V _I = V _{IHC} or V _{ILC} V _{I/O} = V _{CC} or V _{EE} I _{I/O} ≤ 2mA		150						
		4.5	GND			70	150		190		230	
		4.5	-4.5			50	100		125		150	
		6.0	-6.0			45	80		100		120	
ΔR _{ON}	Difference of ON resistance between switches	4.5	GND	V _I = V _{IHC} or V _{ILC} V _{I/O} = V _{CC} or V _{EE} I _{I/O} ≤ 2mA		10	30		35		45	W
		4.5	-4.5			5	12		15		18	
		6.0	-6.0			5	10		12		15	
I _{OFF}	Input/output leakage current (switch off)	6.0	GND	V _{OS} = V _{CC} or GND V _{IS} = GND or V _{CC} V _I = V _{ILC} or V _{IHC}			±0.06		±0.6		±1.2	μA
		6.0	-6.0				±0.1		±1		±2	
I _{Iz}	Switch input leakage current (switch on, output open)	6.0	GND	V _{OS} = V _{CC} or GND V _I = V _{IHC} or V _{ILC}			±0.06		±0.6		±1.2	μA
		6.0	-6.0				±0.1		±1		±2	
I _I	Input leakage current	6.0	GND	V _I = V _{CC} or GND			±0.1		±0.1		±1	μA
I _{CC}	Quiescent supply current	6.0	GND	V _I = V _{CC} or GND			4		40		80	μA
		6.0	-6.0				8		80		160	

Table 7. AC electrical characteristics ($C_L = 50$ pF, Input $t_r = t_f = 6$ ns)

Symbol	Parameter	Test condition			Value						Unit	
		V_{CC} (V)	V_{EE} (V)		$T_A = 25^\circ\text{C}$			-40 to 85°C		-55 to 125°C		
					Min.	Typ	Max	Min	Max	Min		Max
$\Phi_{I/O}$	Phase difference between input and output	2.0	GND			25	60		75		90	ns
		4.5	GND			6	12		15		18	
		6.0	GND			5	10		13		15	
		4.5	-4.5			4						
t_{PZL} t_{PZH}	Output enable time	2.0	GND	$R_L = 1\text{ K}\Omega$		64	225		280		340	ns
		4.5	GND			18	45		56		68	
		6.0	GND			15	38		48		58	
		4.5	-4.5			18						
t_{PLZ} t_{PHZ}	Output disable time	2.0	GND	$R_L = 1\text{ K}\Omega$		100	250		315		375	ns
		4.5	GND			33	50		63		70	
		6.0	GND			28	43		54		64	
		4.5	-4.5			29						

Table 8. Capacitive characteristics

Symbol	Parameter	Test condition			Value						Unit	
		V_{CC} (V)	V_{EE} (V)		$T_A = 25^\circ\text{C}$			-40 to 85°C		-55 to 125°C		
					Min	Typ	Max	Min	Max	Min		Max
C_{IN}	Input capacitance	5.0				5	10		10		10	pF
$C_{I/O}$	Common terminal capacitance	5.0	-5.0			36	70		70		70	pF
$C_{I/O}$	Switch terminal capacitance	5.0	-5.0			7	15		15		15	pF
C_{IOS}	Feed through capacitance	5.0	-5.0			0.95	2		2		2	pF
C_{PD}	Power dissipation capacitance (1)	5.0	GND			70						pF

1. C_{PD} is defined as the value of the IC's internal equivalent capacitance which is calculated from the operating current consumption without load. (Refer to Test Circuit). Average operating current can be obtained by the following equation.
 $I_{CC(opr)} = C_{PD} \times V_{CC} \times f_{IN} + I_{CC}$

Table 9. Analog switch characteristics (GND = 0 V; T_A = 25°C)

Symbol	Parameter	Test condition			Value	Unit	
		V _{CC} (V)	V _{EE} (V)	V _{IN} (V _{p-p})	Typ		
	Sine wave distortion	2.25	-2.25	4	f _{IN} = 1 KHz R _L = 10 KΩ C _L = 50 pF	0.025	%
		4.5	-4.5	8		0.020	
		6.0	-6.0	11		0.018	
f _{MAX}	Frequency response (Switch on) ⁽¹⁾	2.25	-2.25	Adjust f _{IN} voltage to obtain 0 dBm at V _{OS} . Increase f _{IN} Frequency until dB meter reads -3dB R _L = 50 Ω, C _L = 10 pF, f _{IN} = 1 KHz sine wave	120	MHz	
		4.5	-4.5		190		
		6.0	-6.0		200		
f _{MAX}	Frequency response (switch on) ⁽²⁾	2.25	-2.25	Adjust f _{IN} voltage to obtain 0 dBm at V _{OS} . Increase f _{IN} Frequency until dB meter reads -3dB R _L = 50Ω, C _L = 10 pF, f _{IN} = 1KHz sine wave	45	MHz	
		4.5	-4.5		70		
		6.0	-6.0		85		
	Feed through attenuation (switch off)	2.25	-2.25	V _{IN} is centered at (V _{CC} - V _{EE})/2 Adjust input for 0 dBm R _L = 600 Ω, C _L = 50 pF, f _{IN} = 1 KHz sine wave	-50	dB	
		4.5	-4.5		-50		
		6.0	-6.0		-50		
	Crosstalk (control input to signal output)	2.25	-2.25	Adjust R _L at set up so that I _S = 0A. R _L = 600 Ω, C _L = 50 pF, f _{IN} = 1 KHz square wave	60	mV	
		4.5	-4.5		140		
		6.0	-6.0		200		
	Crosstalk (between any two switches)	2.25	-2.25	Adjust V _{IN} to obtain 0d Bm at input R _L = 600 Ω, C _L = 50 pF, f _{IN} = 1 KHz sine wave	-50	dB	
		4.5	-4.5		-50		
		6.0	-6.0		-50		

1. Input common terminal, and measured at switch terminal.

2. Input switch terminal, and measured at common terminal.

These characteristics are determined by the design of the device.

2.1 Switching characteristics test circuit

Figure 6. Output enable/disable time

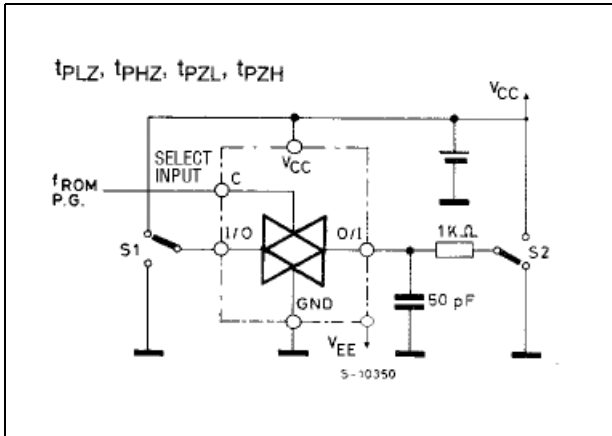

Figure 7. Crosstalk (control to output)

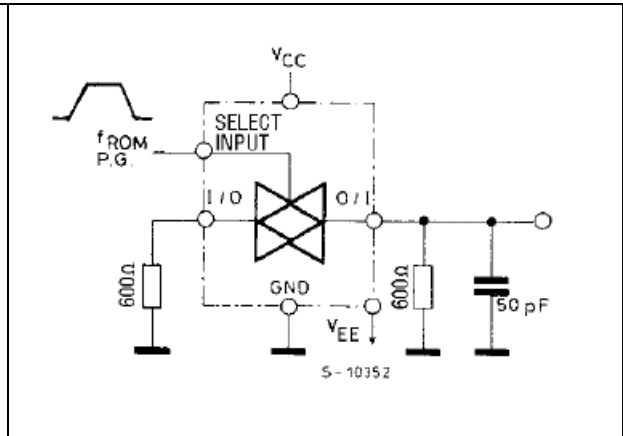

Figure 8. Bandwidth and feedthrough attenuation

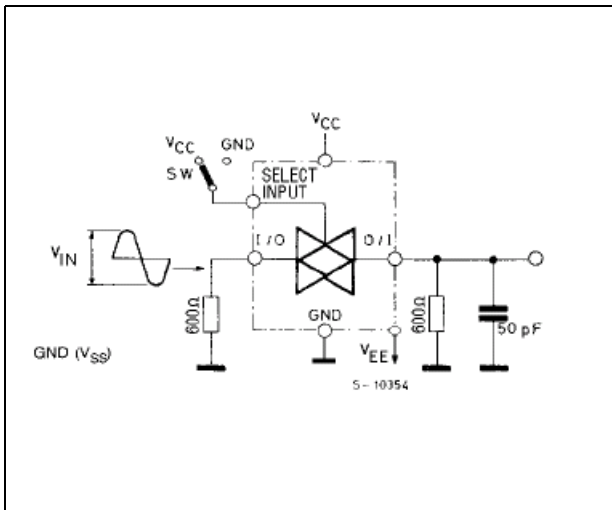

Figure 9. Crosstalk between any two switches

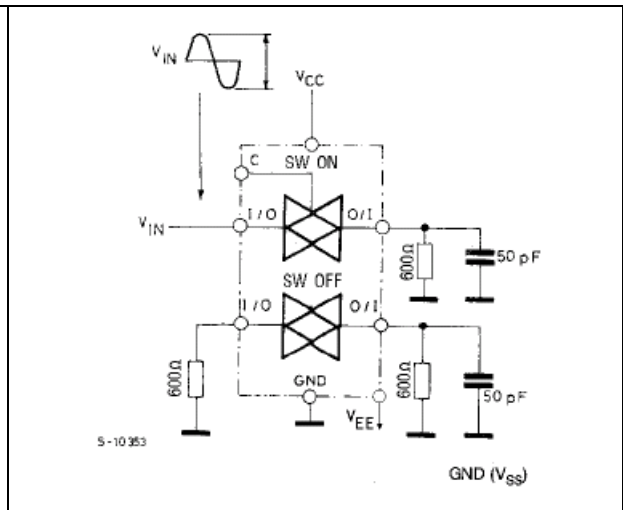

Figure 10. Common terminal capacitance (C_{I-O} , $C_{I/O}$)

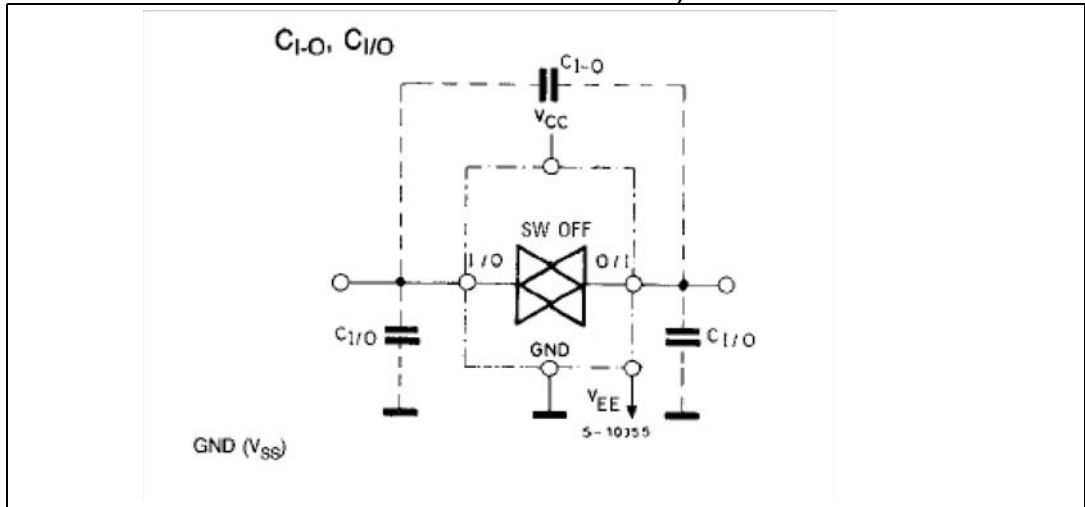

Figure 11. Switching characteristics waveform

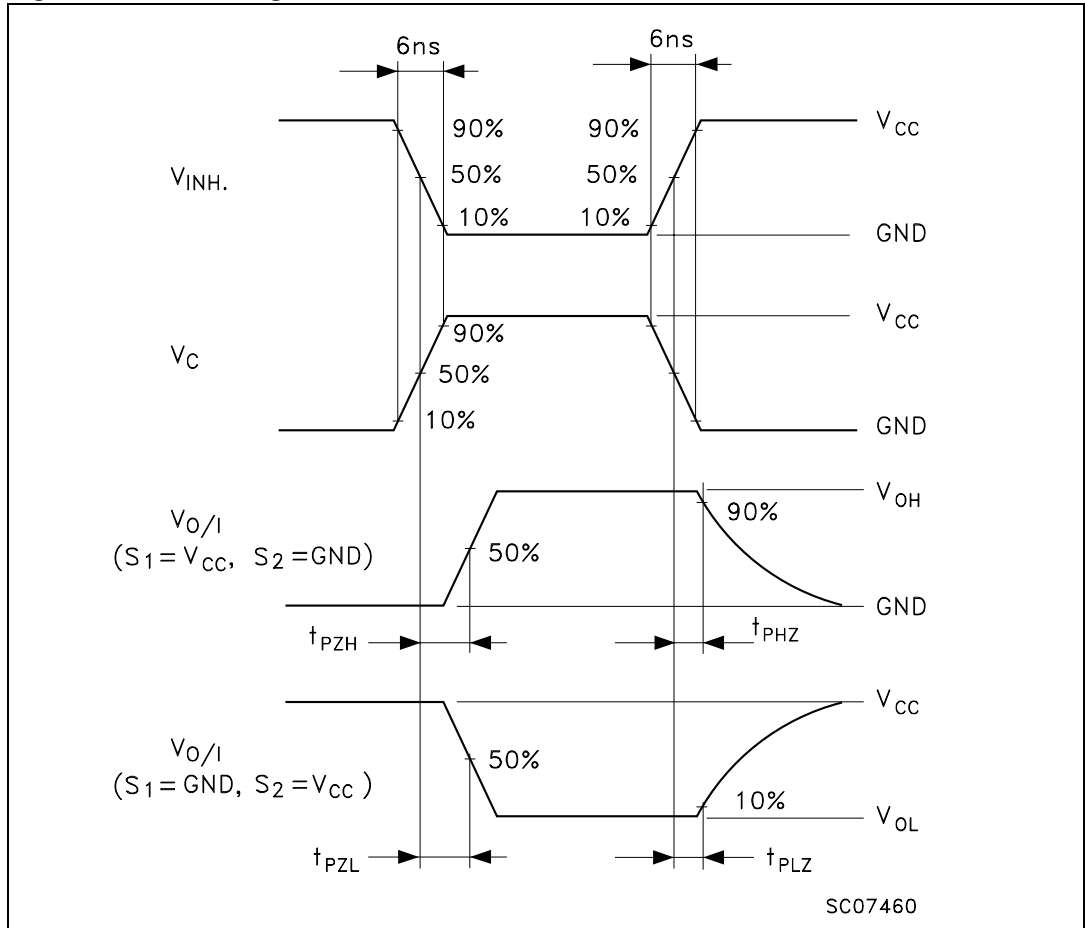

Figure 12. Channel resistance (R_{ON})

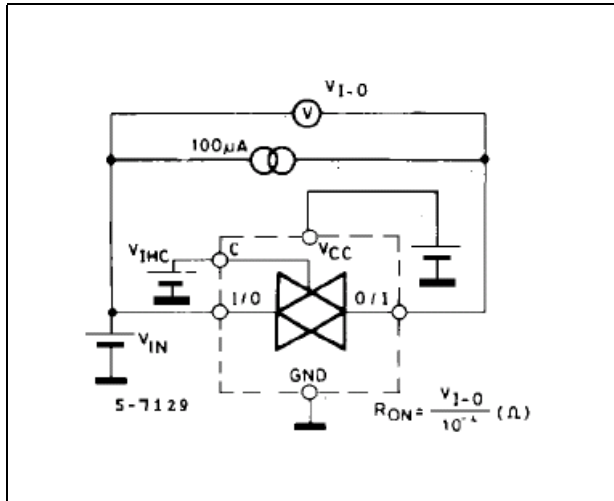
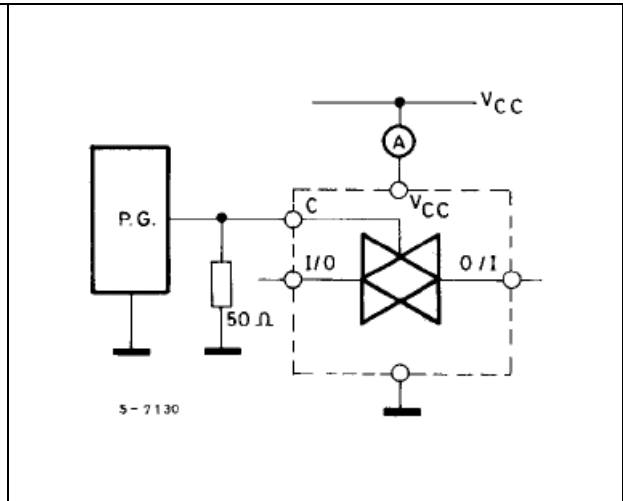

Figure 13. Quiescent supply current - I_{CC} (opr)



3 Package mechanical data

In order to meet environmental requirements, ST offers these devices in ECOPACK® packages. These packages have a Lead-free second level interconnect . The category of second Level Interconnect is marked on the package and on the inner box label, in compliance with JEDEC Standard JESD97. The maximum ratings related to soldering conditions are also marked on the inner box label. ECOPACK is an ST trademark. ECOPACK specifications are available at: www.st.com.

Figure 14. Plastic DIP-16 (0.25) package information

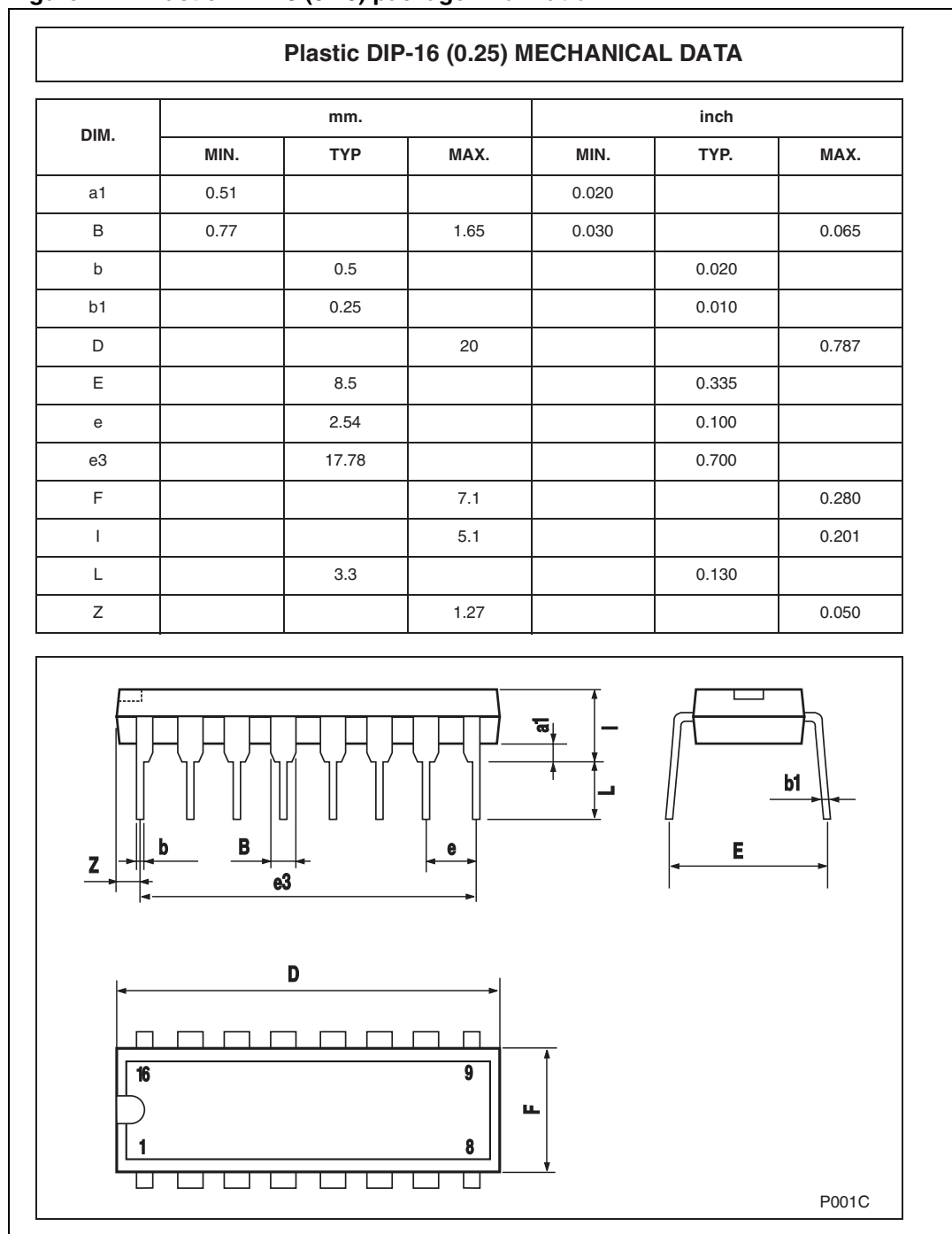

Figure 15. SO-16 package information

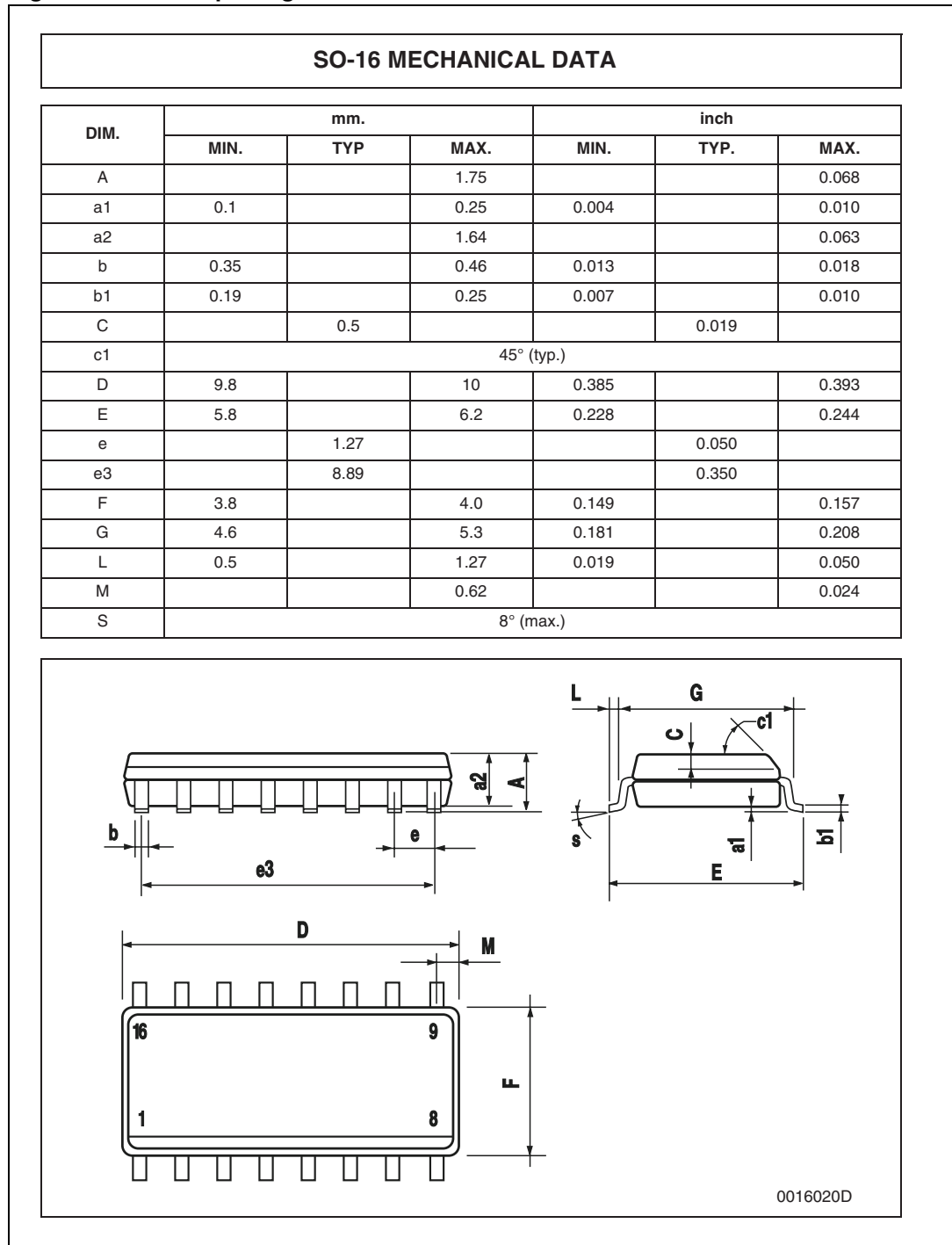
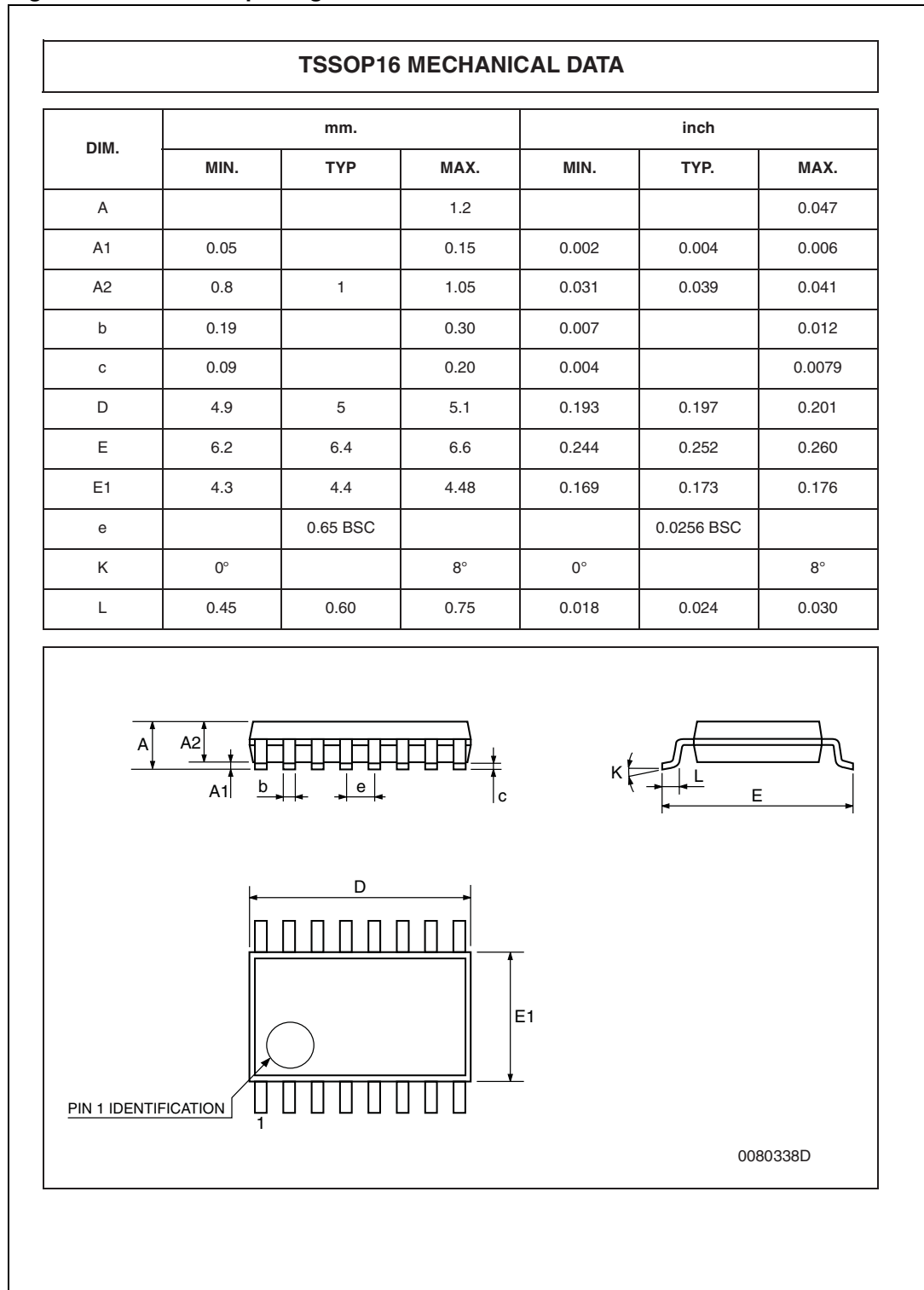

Figure 16. TSSOP16 package information



4 Revision history

Table 10. Document revision history

Date	Revision	Changes
01-Jul-2001	1	Initial release.
21-June-2004	2	Document internal migration, no content change.
10-Mar-2008	3	Document restructured and converted to new ST template, updated Table 4 on page 5 , removed tube packing info.
21-Apr-2008	4	Replaced M74HC4051M13TR with M74HC4051RM13TR in Table 1 on page 1 .

Please Read Carefully:

Information in this document is provided solely in connection with ST products. STMicroelectronics NV and its subsidiaries ("ST") reserve the right to make changes, corrections, modifications or improvements, to this document, and the products and services described herein at any time, without notice.

All ST products are sold pursuant to ST's terms and conditions of sale.

Purchasers are solely responsible for the choice, selection and use of the ST products and services described herein, and ST assumes no liability whatsoever relating to the choice, selection or use of the ST products and services described herein.

No license, express or implied, by estoppel or otherwise, to any intellectual property rights is granted under this document. If any part of this document refers to any third party products or services it shall not be deemed a license grant by ST for the use of such third party products or services, or any intellectual property contained therein or considered as a warranty covering the use in any manner whatsoever of such third party products or services or any intellectual property contained therein.

UNLESS OTHERWISE SET FORTH IN ST'S TERMS AND CONDITIONS OF SALE ST DISCLAIMS ANY EXPRESS OR IMPLIED WARRANTY WITH RESPECT TO THE USE AND/OR SALE OF ST PRODUCTS INCLUDING WITHOUT LIMITATION IMPLIED WARRANTIES OF MERCHANTABILITY, FITNESS FOR A PARTICULAR PURPOSE (AND THEIR EQUIVALENTS UNDER THE LAWS OF ANY JURISDICTION), OR INFRINGEMENT OF ANY PATENT, COPYRIGHT OR OTHER INTELLECTUAL PROPERTY RIGHT.

UNLESS EXPRESSLY APPROVED IN WRITING BY AN AUTHORIZED ST REPRESENTATIVE, ST PRODUCTS ARE NOT RECOMMENDED, AUTHORIZED OR WARRANTED FOR USE IN MILITARY, AIR CRAFT, SPACE, LIFE SAVING, OR LIFE SUSTAINING APPLICATIONS, NOR IN PRODUCTS OR SYSTEMS WHERE FAILURE OR MALFUNCTION MAY RESULT IN PERSONAL INJURY, DEATH, OR SEVERE PROPERTY OR ENVIRONMENTAL DAMAGE. ST PRODUCTS WHICH ARE NOT SPECIFIED AS "AUTOMOTIVE GRADE" MAY ONLY BE USED IN AUTOMOTIVE APPLICATIONS AT USER'S OWN RISK.

Resale of ST products with provisions different from the statements and/or technical features set forth in this document shall immediately void any warranty granted by ST for the ST product or service described herein and shall not create or extend in any manner whatsoever, any liability of ST.

ST and the ST logo are trademarks or registered trademarks of ST in various countries.

Information in this document supersedes and replaces all information previously supplied.

The ST logo is a registered trademark of STMicroelectronics. All other names are the property of their respective owners.

© 2008 STMicroelectronics - All rights reserved

STMicroelectronics group of companies

Australia - Belgium - Brazil - Canada - China - Czech Republic - Finland - France - Germany - Hong Kong - India - Israel - Italy - Japan - Malaysia - Malta - Morocco - Singapore - Spain - Sweden - Switzerland - United Kingdom - United States of America

www.st.com