



Chipsmall Limited consists of a professional team with an average of over 10 year of expertise in the distribution of electronic components. Based in Hongkong, we have already established firm and mutual-benefit business relationships with customers from,Europe,America and south Asia,supplying obsolete and hard-to-find components to meet their specific needs.

With the principle of “Quality Parts,Customers Priority,Honest Operation,and Considerate Service”,our business mainly focus on the distribution of electronic components. Line cards we deal with include Microchip,ALPS,ROHM,Xilinx,Pulse,ON,Everlight and Freescale. Main products comprise IC,Modules,Potentiometer,IC Socket,Relay,Connector.Our parts cover such applications as commercial,industrial, and automotives areas.

We are looking forward to setting up business relationship with you and hope to provide you with the best service and solution. Let us make a better world for our industry!



Contact us

Tel: +86-755-8981 8866 Fax: +86-755-8427 6832

Email & Skype: info@chipsmall.com Web: www.chipsmall.com

Address: A1208, Overseas Decoration Building, #122 Zhenhua RD., Futian, Shenzhen, China



Customer Information Sheet

DRAWING No.: M7965/66/67/71-XX

SHEET 2 OF 2

IF IN DOUBT - ASK

©

NOT TO SCALE

THIRD ANGLE PROJECTION

ALL DIMENSIONS IN mm

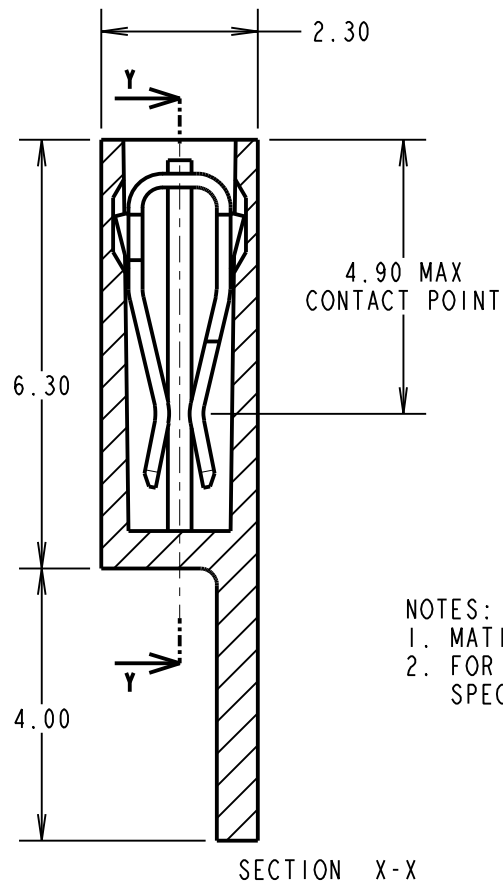
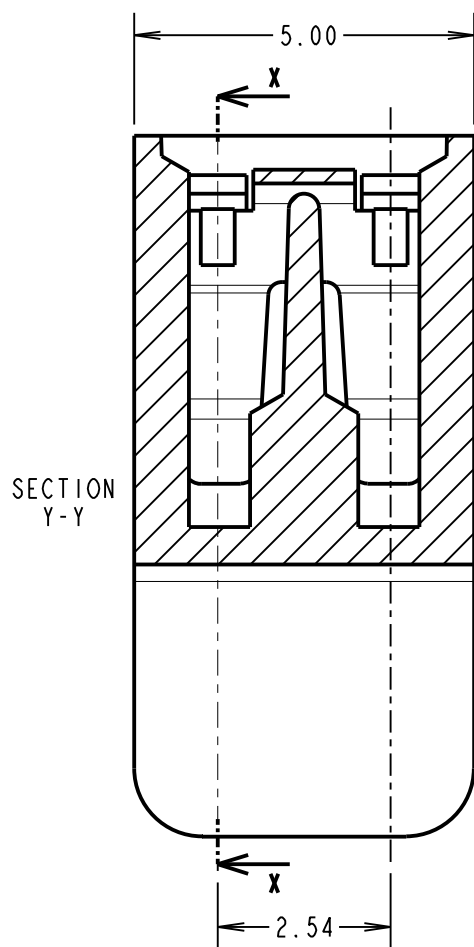

SPECIFICATIONS:

MATERIAL:

MOULDING = GLASS FILLED POLYESTER UL94V-0
(SEE ORDER CODE FOR COLOUR)

CLIP = PHOSPHOR BRONZE

FINISH:

05 = 0.13µ GOLD
46 = 3µ 100% TIN

ELECTRICAL:

CURRENT RATING = 3A MAX
VOLTAGE RATING = 250V AC/DC
VOLTAGE PROOF = 750V AC
CONTACT RESISTANCE = 30mΩ MAX (TIN), 25mΩ MAX (GOLD)
INSULATION RESISTANCE = 1,000MΩ MIN

MECHANICAL:

DURABILITY = 50 OPERATIONS (TIN), 300 OPERATIONS (GOLD)
INSERTION FORCE = 14.5N MAX
WITHDRAWAL FORCE = 1.0N MIN

ENVIRONMENTAL:

TEMPERATURE RANGE = -40°C TO +85°C

PACKING:

BAG

NOTES:

- MATING PIN = 0.64mm SQUARE,
- FOR COMPLETE SPECIFICATIONS, SEE COMPONENT SPECIFICATION C003XX (LATEST ISSUE).

ORDER CODE:

M79XX-XX

MOULDING COLOUR

65 - LT. GREY 66 - RED
67 - BLACK 71 - BLUE

CONTACT FINISH

05 - GOLD
46 = 100% TIN

MSP	8	22.10.14	12634
NAME	ISS.	DATE	C/NOTE
APPROVED:		M.PERREN	
CHECKED:		M.PLESTED	
DRAWN:		J.CLAY	
CUSTOMER REF.:			
ASSEMBLY DRG:			

HARWIN

www.harwin.com
technical@harwin.com

THIS DRAWING AND ANY INFORMATION OR DESCRIPTIVE MATTER SET OUT HEREON ARE CONFIDENTIAL AND COPYRIGHT PROPERTY OF THE HARWIN GROUP AND MUST NOT BE DISCLOSED, LOANED, COPIED OR USED FOR MANUFACTURING, TENDERING OR FOR ANY OTHER PURPOSE WITHOUT THEIR WRITTEN PERMISSION.

TOLERANCES

X. = ±1mm
X.X = ±0.25mm
X.XX = ±0.10mm
X.XXX = ±0.01mm

ANGLES = ±5°
UNLESS STATED

MATERIAL:

SEE ABOVE

FINISH:

SEE ABOVE

S/AREA:

mm²

TITLE:

JUMPER SOCKET
(CLOSED TOP WITH HANDLE)

DRAWING NUMBER:

**M7965-XX, M7966-XX,
M7967-XX, M7971-XX**

SHT
2
OF
2