



Chipsmall Limited consists of a professional team with an average of over 10 year of expertise in the distribution of electronic components. Based in Hongkong, we have already established firm and mutual-benefit business relationships with customers from,Europe,America and south Asia,supplying obsolete and hard-to-find components to meet their specific needs.

With the principle of “Quality Parts,Customers Priority,Honest Operation,and Considerate Service”,our business mainly focus on the distribution of electronic components. Line cards we deal with include Microchip,ALPS,ROHM,Xilinx,Pulse,ON,Everlight and Freescale. Main products comprise IC,Modules,Potentiometer,IC Socket,Relay,Connector.Our parts cover such applications as commercial,industrial, and automotives areas.

We are looking forward to setting up business relationship with you and hope to provide you with the best service and solution. Let us make a better world for our industry!



Contact us

Tel: +86-755-8981 8866 Fax: +86-755-8427 6832

Email & Skype: info@chipsmall.com Web: www.chipsmall.com

Address: A1208, Overseas Decoration Building, #122 Zhenhua RD., Futian, Shenzhen, China



Customer Information Sheet

DRAWING No.: M80-400000FG-XX-XXX-00-000

SHEET 4 OF 6

IF IN DOUBT - ASK

©

NOT TO SCALE

THIRD ANGLE PROJECTION

ALL DIMENSIONS IN mm

SPECIFICATIONS:

MATERIAL:
 MOULDING: GLASS FILLED PPS, UL94V-0, BLACK
 COAX CONTACT:
 BODY, SLEEVE, END PLUG = COPPER ALLOY
 INNER CONTACT, LATCHING COLLAR = BERYLLIUM COPPER
 INSULATOR = PTFE
 JACKSCREW, CIRCLIP = STAINLESS STEEL
FINISH:
 COAX CONTACT
 BODY, SLEEVE, INNER CONTACT, END PLUG = GOLD
 LATCHING COLLAR: = NICKEL
ELECTRICAL:
 INSULATION RESISTANCE = 100MΩ MIN
 COAX CONTACT:
 FREQUENCY RANGE = 6GHz
 IMPEDANCE = 50Ω
 V.S.W.R = 1.05 + (0.04 x FREQUENCY) GHz MAX
 CONTACT RESISTANCE = 6mΩ MAX
 INSULATION RESISTANCE = 10⁶MΩ @250V AC
 OPERATING VOLTAGE = 180V AC @ 500mA
 MAXIMUM VOLTAGE = 1000V AC
MECHANICAL:
 DURABILITY = 500 OPERATIONS
 COAX CONTACT:
 INSERTION FORCE = 8N MAX
 WITHDRAWAL FORCE = 0.5N MIN
ENVIRONMENTAL:
 TEMPERATURE RANGE = -55°C TO +125°C
PACKING:
 BAG
 FOR COMPLETE SPECIFICATION SEE COMPONENT SPECIFICATION C005XX (LATEST ISSUE)

COAX CRIMP AND SOLDER CONTACTS ONLY

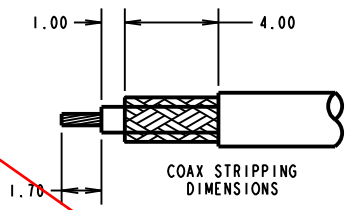
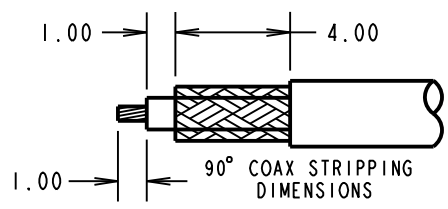
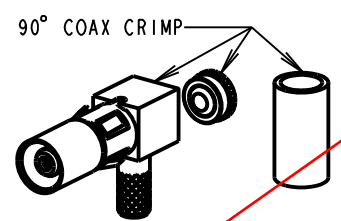
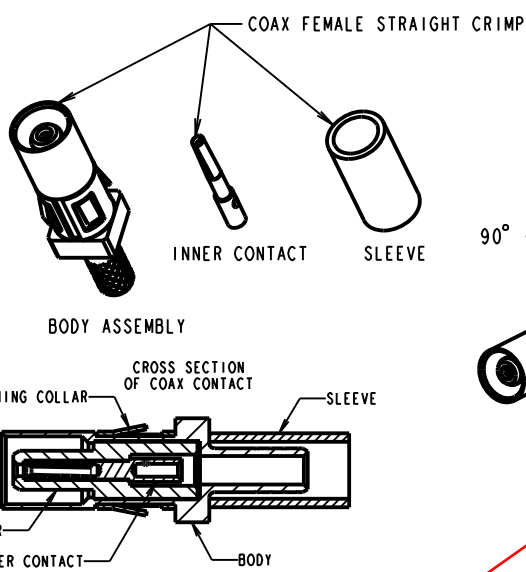
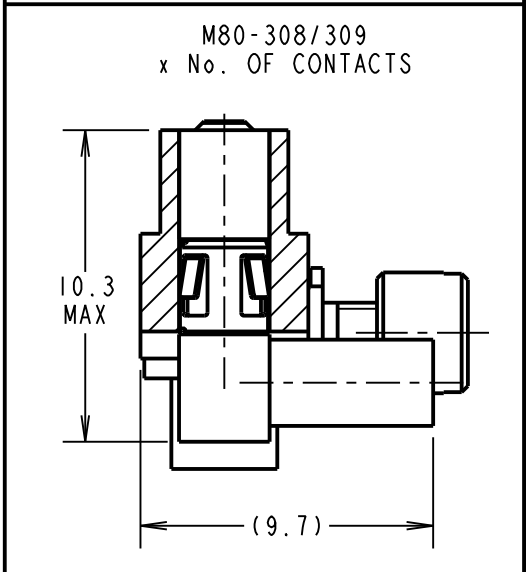
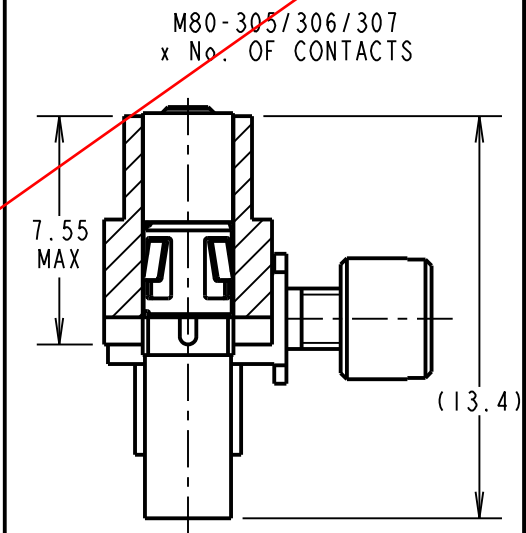
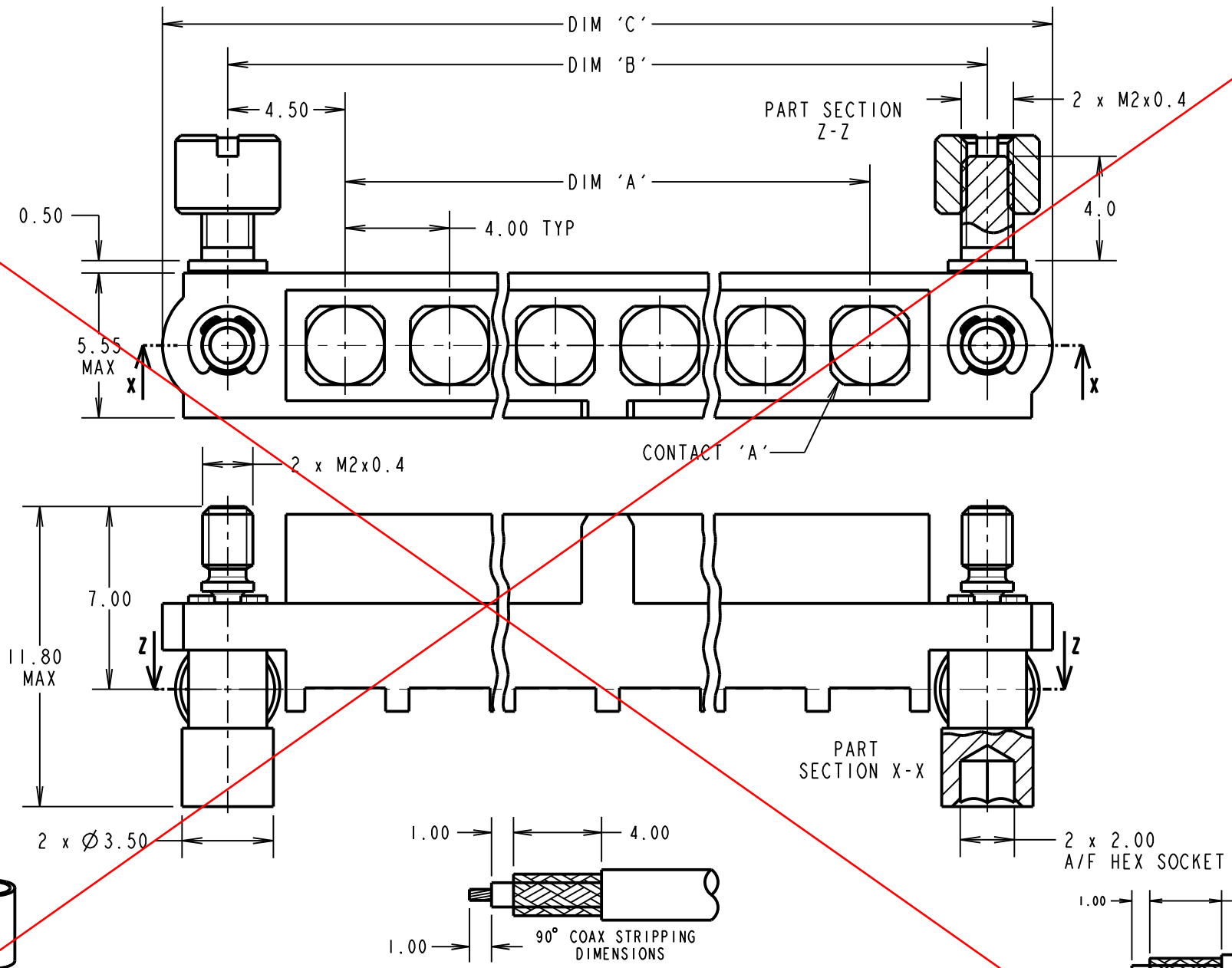

OBSOLETE

ORDER CODE: (COAX CRIMP/SOLDER)
M80-400000FG-XX-XXX-00-000
 TOTAL No. OF CONTACTS: _____
 02 TO 12
 SPECIAL CONTACTS:
 305 = COAX CONTACT CRIMP 2.0mm M80-305
 306 = COAX CONTACT CRIMP 2.4mm M80-306
 307 = COAX CONTACT CRIMP 2.7mm M80-307
 308 = 90° COAX CONTACT CRIMP/SOLDER 2.0mm M80-308
 309 = 90° COAX CONTACT CRIMP/SOLDER 2.7mm M80-309

- NOTES:
- CONNECTORS ARE SUPPLIED WITH CONTACTS LOOSE.
 - COAX CONTACT IS SUPPLIED AS A KIT OF PARTS: BODY, INSULATOR AND LATCHING COLLAR ARE PRE-ASSEMBLED. SLEEVE AND INNER CONTACT ARE SEPARATE.
 - FOR EXTRA COAX CONTACTS, USE PART NUMBER M80-305/306/307/308/309.
 - RECOMMENDED HAND CRIMP TOOL FOR COAX INNER CONTACT = Z80-292 WITH POSITIONER Z80-291 AND RECOMMENDED HAND CRIMP TOOL AND DIE SET FOR COAX SLEEVE = Z80-293.
 - COAX CONTACT EXTRACTION TOOL = Z80-290.
 - INSTRUCTION SHEETS ARE AVAILABLE.

DIMENSION	CALCULATION
DIM 'A'	4 x No. OF CONTACTS - 4.00
DIM 'B'	4 x No. OF CONTACTS + 5.00
DIM 'C'	4 x No. OF CONTACTS + 10.00
EXAMPLE: CONNECTOR WITH 08 COAX CONTACTS, M80-400000FG-08-305-00-000 DIM 'A' = 28.00mm, DIM 'B' = 37.00mm, DIM 'C' = 42.00mm	

MSP	2	11.05.15	12566
NAME	ISS.	DATE	C/NOTE
APPROVED:		M.PERREN	
CHECKED:		S.BENNETT	
DRAWN:		C.PENROSE	
CUSTOMER REF.:			
ASSEMBLY DRG:			

HARWIN
 www.harwin.com
 technical@harwin.com

THIS DRAWING AND ANY INFORMATION OR DESCRIPTIVE MATTER SET OUT HEREON ARE CONFIDENTIAL AND COPYRIGHT PROPERTY OF THE HARWIN GROUP AND MUST NOT BE DISCLOSED, LOANED, COPIED OR USED FOR MANUFACTURING, TENDERING OR FOR ANY OTHER PURPOSE WITHOUT THEIR WRITTEN PERMISSION.

TOLERANCES
 X. = ±1mm
 X.X = ±0.50mm
 X.XX = ±0.10mm
 X.XXX = ±0.01mm
 ANGLES = ±5°
 UNLESS STATED

MATERIAL: SEE ABOVE
 FINISH: SEE ABOVE
 S/AREA: mm²

TITLE: JACKSCREW DATAMATE MIXED TECHNOLOGY FEMALE ASSY WITH HEX SOCKET J/SCREWS AND BOARD MOUNT
 DRAWING NUMBER: **M80-400000FG-XX-XXX-00-000**
 SHT 4 OF 6

Customer Information Sheet

DRAWING No.: M80-400000FG-XX-XXX-00-000

SHEET 5 OF 6

IF IN DOUBT - ASK

(C)

NOT TO SCALE

THIRD ANGLE PROJECTION

ALL DIMENSIONS IN mm

SPECIFICATIONS:

MATERIAL:
 Moulding: GLASS FILLED PPS, UL94V-0, BLACK
 POWER CONTACT:
 BODY = COPPER ALLOY
 LATCHING COLLAR = BERYLLIUM COPPER
 JACKSCREW, CIRCLIP = STAINLESS STEEL
FINISH:
 POWER CONTACT:
 BODY, SLEEVE, INNER CONTACT, END PLUG = GOLD
 LATCHING COLLAR = NICKEL
ELECTRICAL:
 WORKING VOLTAGE = 800V AC/DC
 VOLTAGE PROOF = 1200V AC/DC
 INSULATION RESISTANCE = 100MΩ MIN
 POWER CONTACT:
 CONTACT RESISTANCE = 6mΩ MAX
 CURRENT RATING = M80-325 = 20A MAX WITH 12AWG
 M80-326 = 15A MAX WITH 14AWG
 M80-327 = 10A MAX WITH 16AWG
 M80-328 = 8A MAX WITH 18AWG
 M80-329 = 5A MAX WITH 20AWG
 M80-32A = 20A MAX WITH 12AWG
 M80-32B = 15A MAX WITH 14AWG
 M80-32C = 10A MAX WITH 16AWG
 M80-PF5 = 40A MAX WITH 10AWG
 CONTACT AS SPECIFIED

MECHANICAL:
 DURABILITY = 500 OPERATIONS
 POWER CONTACT:
 INSERTION FORCE:
 M80-325/326/327/328/329/
 32A/32B/32C = 8N MAX
 M80-PF5 = 15N MAX
 WITHDRAWAL FORCE = 0.5N MIN
ENVIRONMENTAL:
 TEMPERATURE RANGE:
 M80-325/326/327/328/329/
 32A/32B/32C = -55°C TO +125°C
 M80-PF5 = -55°C TO +150°C

PACKING:
 BAG
 FOR COMPLETE SPECIFICATION SEE COMPONENT SPECIFICATION C005XX (LATEST ISSUE)

POWER CRIMP AND SOLDER CONTACTS ONLY

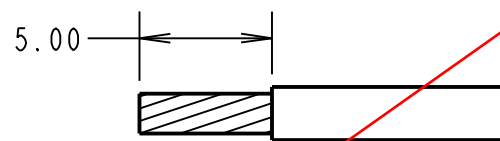
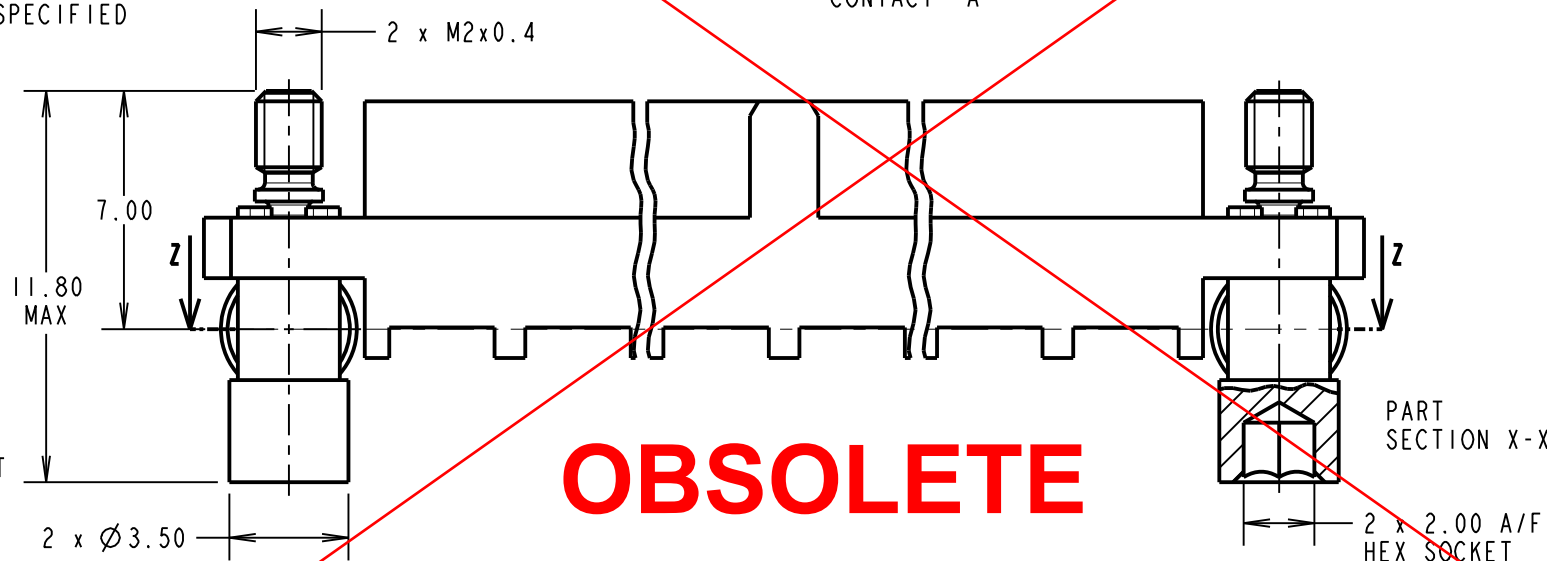
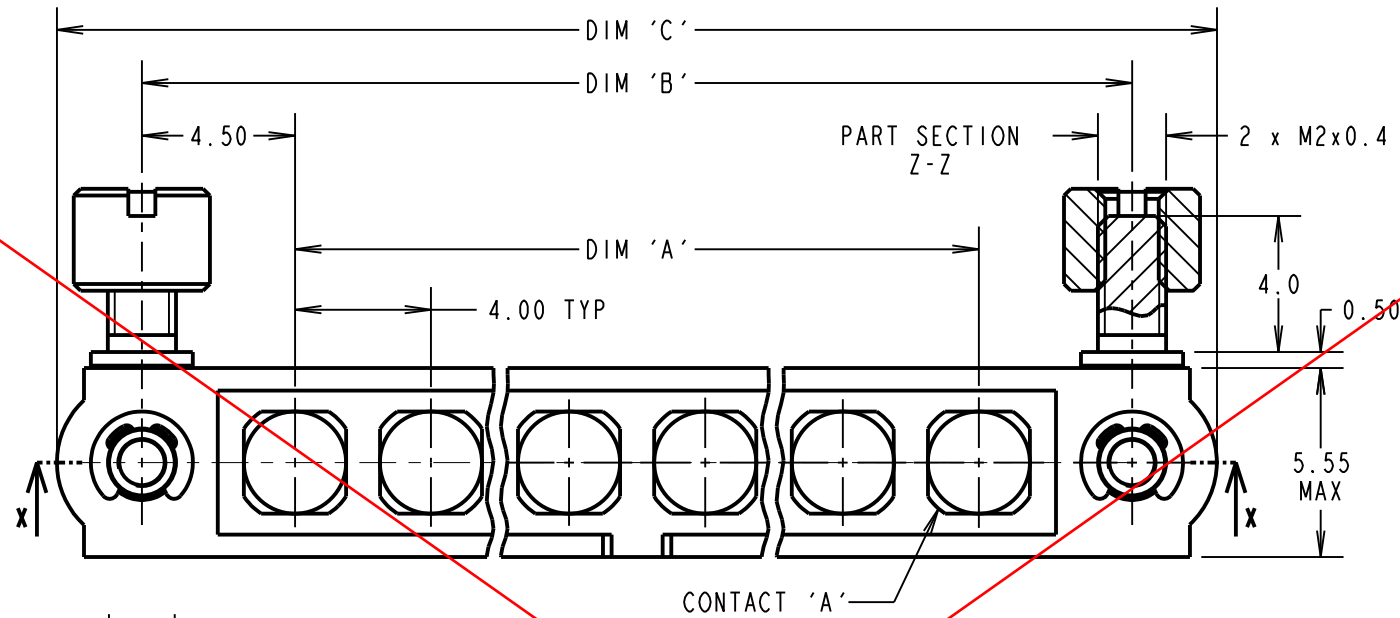

OBSOLETE

ORDER CODE: (POWER CRIMP/SOLDER)
M80-400000FG-XX-XXX-00-000

TOTAL No. OF CONTACTS: _____
 02 TO 12
 SPECIAL CONTACTS:
 325 = POWER CONTACT SOLDER 12AWG M80-325
 326 = POWER CONTACT SOLDER 14AWG M80-326
 327 = POWER CONTACT SOLDER 16AWG M80-327
 328 = POWER CONTACT SOLDER OR CRIMP 18AWG M80-328
 329 = POWER CONTACT SOLDER OR CRIMP 20AWG M80-329
 32A = 90° POWER CONTACT SOLDER 12AWG M80-32A
 32B = 90° POWER CONTACT SOLDER 14AWG M80-32B
 32C = 90° POWER CONTACT SOLDER 16AWG M80-32C
 PF5 = POWER CONTACT SOLDER 10AWG M80-PF5

- NOTES:**
- CONNECTORS ARE SUPPLIED WITH CONTACTS LOOSE.
 - FOR EXTRA POWER CONTACTS, USE PART NUMBERS:
 M80-325/326/327/328/329/32A/32B/32C/PF5.
 - POWER CONTACT EXTRACTION TOOL = Z80-290.
 - INSTRUCTION SHEETS ARE AVAILABLE.
 - RECOMMENDED HAND CRIMP TOOL FOR CONTACTS
 M80-328/329 = Z80-294 WITH POSITIONER Z80-295.
 - POWER CONTACT WIRE, STRIP BY 5.00mm MINIMUM.

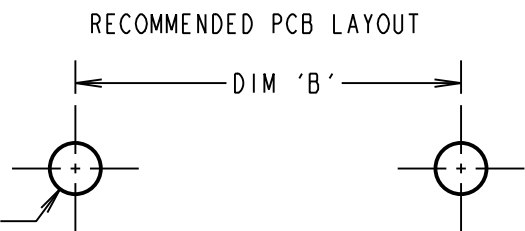
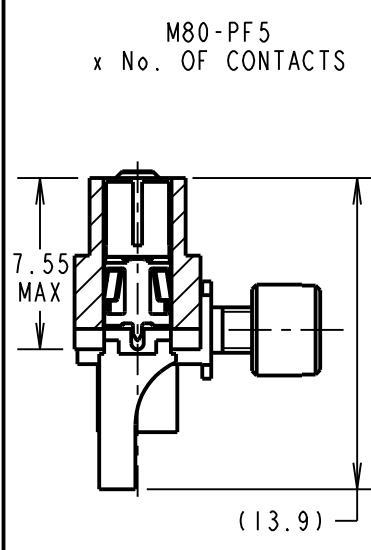
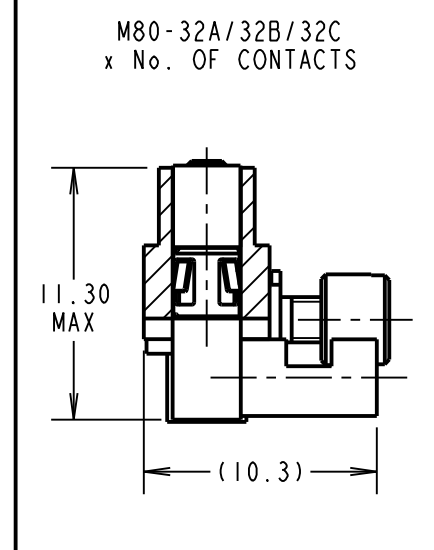
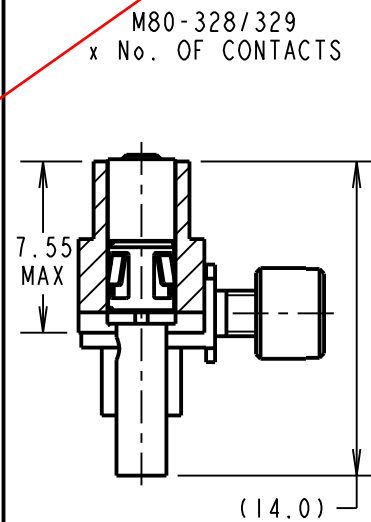
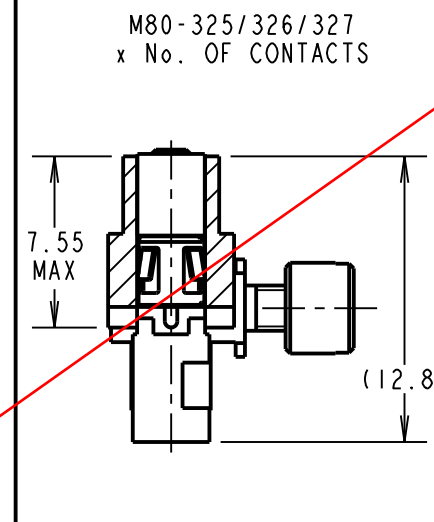

DIMENSION	CALCULATION
DIM 'A'	4 x No. OF CONTACTS - 4.00
DIM 'B'	4 x No. OF CONTACTS + 5.00
DIM 'C'	4 x No. OF CONTACTS + 10.00
EXAMPLE: CONNECTOR WITH 08 POWER CONTACTS, M80-400000FG-08-305-00-000 DIM 'A' = 28.00mm, DIM 'B' = 37.00mm, DIM 'C' = 42.00mm	

MSP	2	11.05.15	12566
NAME	ISS.	DATE	C/NOTE
APPROVED:	M.PERREN		
CHECKED:	S.BENNETT		
DRAWN:	C.PENROSE		
CUSTOMER REF.:			
ASSEMBLY DRG:			

HARWIN
 www.harwin.com
 technical@harwin.com

THIS DRAWING AND ANY INFORMATION OR DESCRIPTIVE MATTER SET OUT HEREON ARE CONFIDENTIAL AND COPYRIGHT PROPERTY OF THE HARWIN GROUP AND MUST NOT BE DISCLOSED, LOANED, COPIED OR USED FOR MANUFACTURING, TENDERING OR FOR ANY OTHER PURPOSE WITHOUT THEIR WRITTEN PERMISSION.

TOLERANCES
 X. = ±1mm
 X.X = ±0.50mm
 X.XX = ±0.10mm
 X.XXX = ±0.01mm
 ANGLES = ±5°
 UNLESS STATED

MATERIAL:
 SEE ABOVE
FINISH: SEE ABOVE
S/AREA: mm²

TITLE: JACKSCREW DATAMATE MIXED TECHNOLOGY FEMALE ASSY WITH HEX SOCKET J/SCREWS AND BOARD MOUNT
DRAWING NUMBER: M80-400000FG-XX-XXX-00-000
 SHT 5 OF 6

Customer Information Sheet

DRAWING No.: M80-400000FG-XX-XXX-00-000

SHEET 6 OF 6

IF IN DOUBT - ASK

(C)

NOT TO SCALE

THIRD ANGLE PROJECTION

ALL DIMENSIONS IN mm

SPECIFICATIONS:

MATERIAL:
 MOULDING: GLASS FILLED PPS, UL94V-0, BLACK
 POWER CONTACT: COPPER ALLOY
 COAX CONTACT:
 BODY = COPPER ALLOY
 INNER CONTACT = COPPER ALLOY
 INSULATOR = PTFE
 JACKSCREW, CIRCLIP = STAINLESS STEEL
FINISH:
 POWER CONTACT: GOLD
 COAX CONTACT: BODY, INNER CONTACT = GOLD
ELECTRICAL:
 WORKING VOLTAGE = 800V AC/DC
 VOLTAGE PROOF = 1200V AC/DC
 INSULATION RESISTANCE = 100MΩ MIN
POWER CONTACT:
 CONTACT RESISTANCE = 6mΩ MAX
CURRENT RATING:
 M80-323/324 = 20A MAX
 M80-PF3/PF4 = 40A MAX
MECHANICAL:
 DURABILITY = 500 OPERATIONS
POWER CONTACT:
 INSERTION FORCE:
 M80-323/324 = 8N MAX
 M80-PF3/PF4 = 15N MAX
 WITHDRAWAL FORCE = 0.5N MIN
ENVIRONMENTAL:
 TEMPERATURE RANGE:
 M80-323/324 = -55°C TO +125°C
 M80-PF3/PF4 = -55°C TO +150°C
PACKING:
 TUBE
 FOR COMPLETE SPECIFICATION SEE COMPONENT SPECIFICATION C005XX (LATEST ISSUE)

PC TAIL HORIZONTAL CONTACTS ONLY

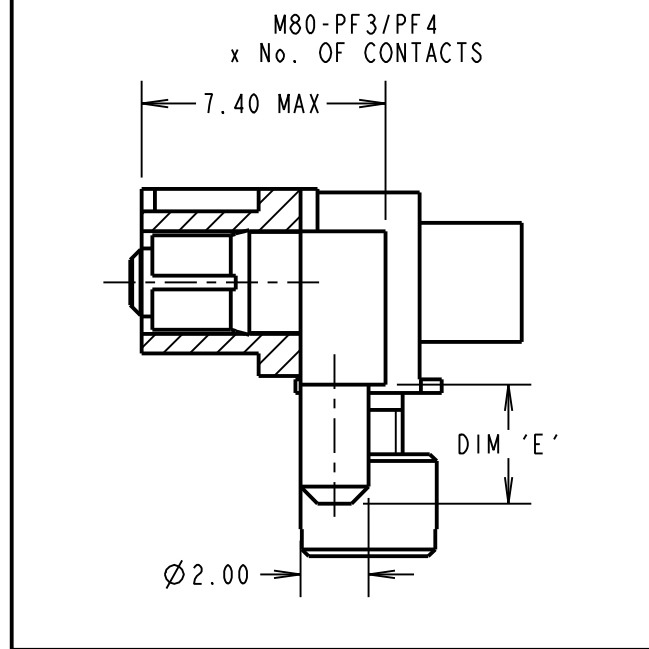
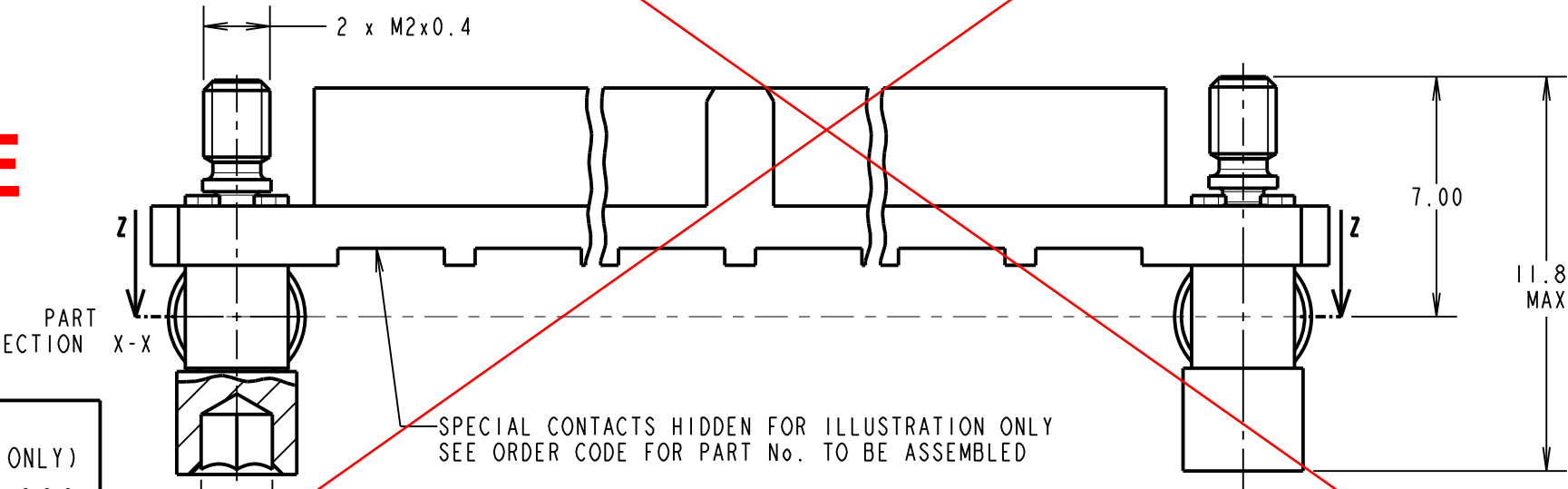
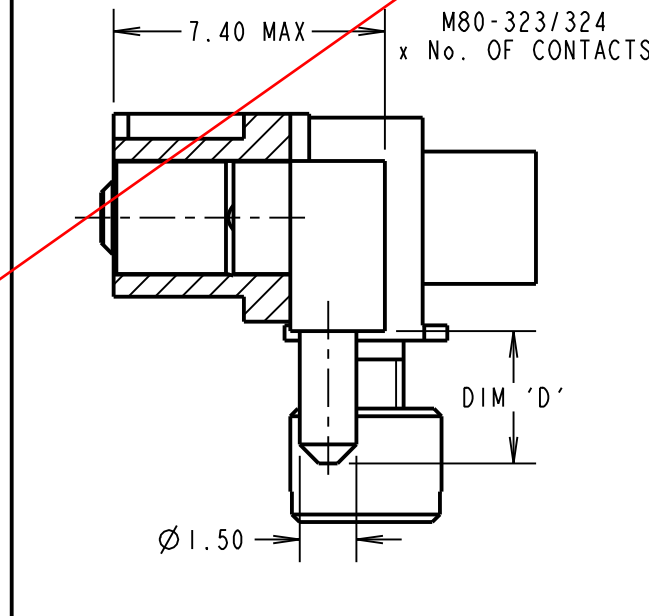
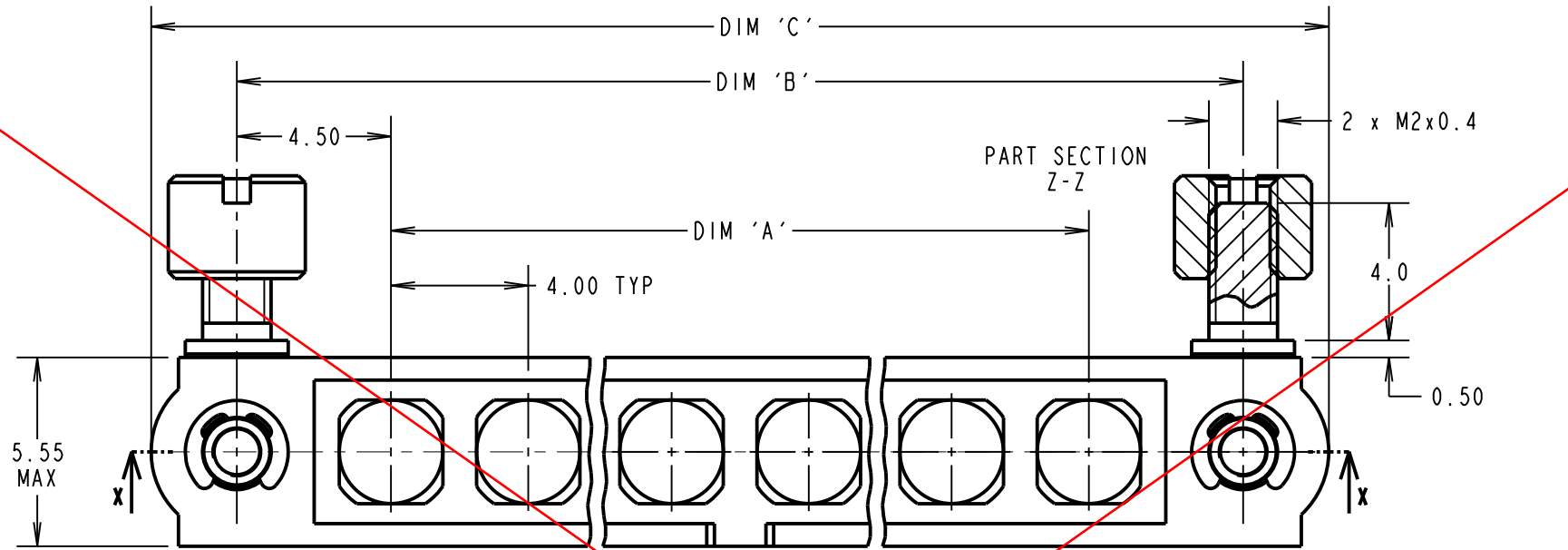

OBSOLETE

ORDER CODE:
 (FEMALE HORIZONTAL POWER CONTACTS ONLY)
M80-400000FG-XX-XXX-00-000
 TOTAL No. OF CONTACTS: 02 TO 12
 FEMALE HORIZONTAL POWER CONTACTS:
 323 = 20A POWER CONTACT PC TAIL 3.5mm M80-323
 324 = 20A POWER CONTACT PC TAIL 5.0mm M80-324
 PF3 = 40A POWER CONTACT PC TAIL 3.5mm M80-PF3
 PF4 = 40A POWER CONTACT PC TAIL 5.0mm M80-PF4

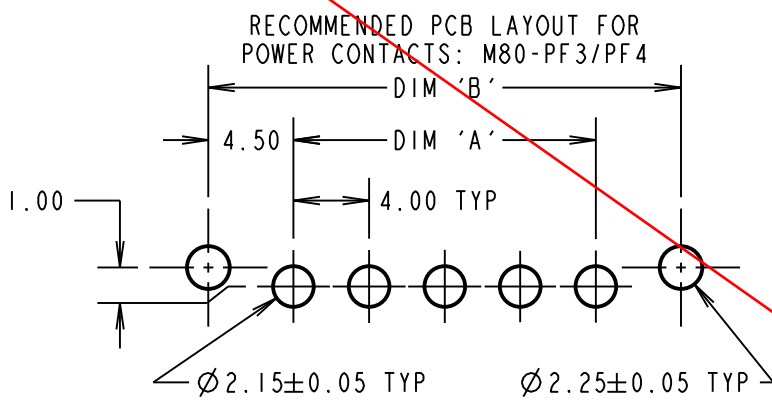
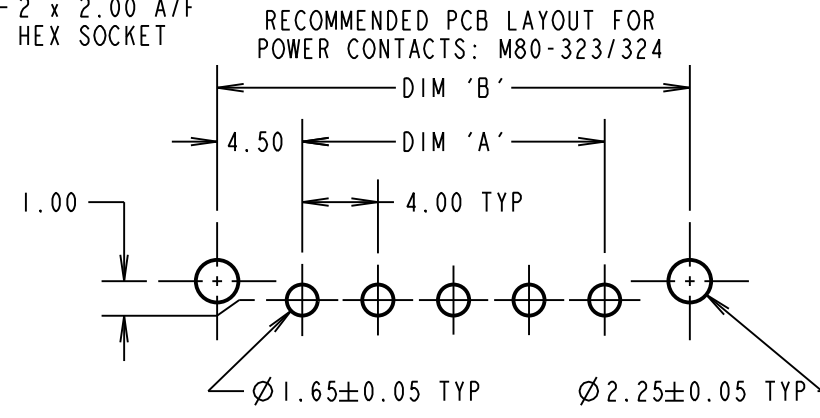

DIMENSION	CALCULATION
DIM 'A'	4 x No. OF CONTACTS - 4.00
DIM 'B'	4 x No. OF CONTACTS + 5.00
DIM 'C'	4 x No. OF CONTACTS + 10.00
DIM 'D'	M80-323 = 3.50mm, M80-324 = 5.00mm
DIM 'E'	M80-PF3 = 3.50mm, M80-PF4 = 5.00mm

EXAMPLE 1: CONNECTOR WITH 10 POWER CONTACTS 3.5mm,
 M80-400000FG-10-323-00-000
 DIM 'A' = 36.00mm, DIM 'B' = 45.00mm, DIM 'C' = 50.00mm
 DIM 'D' = 3.50mm

MSP	2	11.05.15	12566
NAME	ISS.	DATE	C/NOTE
APPROVED:	M.PERREN		
CHECKED:	S.BENNETT		
DRAWN:	C.PENROSE		
CUSTOMER REF.:			
ASSEMBLY DRG:			

HARWIN
 www.harwin.com
 technical@harwin.com

THIS DRAWING AND ANY INFORMATION OR DESCRIPTIVE MATTER SET OUT HEREON ARE CONFIDENTIAL AND COPYRIGHT PROPERTY OF THE HARWIN GROUP AND MUST NOT BE DISCLOSED, LOANED, COPIED OR USED FOR MANUFACTURING, TENDERING OR FOR ANY OTHER PURPOSE WITHOUT THEIR WRITTEN PERMISSION.

TOLERANCES
 X. = ±1mm
 X.X = ±0.50mm
 X.XX = ±0.10mm
 X.XXX = ±0.01mm
 ANGLES = ±5°
 UNLESS STATED

MATERIAL:
 SEE ABOVE
FINISH:
 SEE ABOVE
S/AREA:
 mm²

TITLE:
 JACKSCREW DATAMATE MIXED TECHNOLOGY FEMALE ASSY WITH HEX SOCKET J/SCREWS AND BOARD MOUNT
DRAWING NUMBER:
M80-400000FG-XX-XXX-00-000