



Chipsmall Limited consists of a professional team with an average of over 10 year of expertise in the distribution of electronic components. Based in Hongkong, we have already established firm and mutual-benefit business relationships with customers from,Europe,America and south Asia,supplying obsolete and hard-to-find components to meet their specific needs.

With the principle of “Quality Parts,Customers Priority,Honest Operation,and Considerate Service”,our business mainly focus on the distribution of electronic components. Line cards we deal with include Microchip,ALPS,ROHM,Xilinx,Pulse,ON,Everlight and Freescale. Main products comprise IC,Modules,Potentiometer,IC Socket,Relay,Connector.Our parts cover such applications as commercial,industrial, and automotives areas.

We are looking forward to setting up business relationship with you and hope to provide you with the best service and solution. Let us make a better world for our industry!



## Contact us

Tel: +86-755-8981 8866 Fax: +86-755-8427 6832

Email & Skype: info@chipsmall.com Web: www.chipsmall.com

Address: A1208, Overseas Decoration Building, #122 Zhenhua RD., Futian, Shenzhen, China



# Customer Information Sheet

DRAWING No.: M80-5C1XXXXB1 SHEET 2 OF 2

IF IN DOUBT - ASK

©

NOT TO SCALE

THIRD ANGLE PROJECTION

ALL DIMENSIONS IN mm

**SPECIFICATIONS:**

**MATERIAL:**  
 MOULDING = GLASS-FILLED PPS, UL94V-0, BLACK  
 CONTACT = BRASS  
 PANEL MOUNT & NUT = STAINLESS STEEL  
 BACKSHELL = ALUMINIUM ALLOY

**FINISH:**  
 CONTACT = 0.75µ GOLD ALL OVER  
 BACKSHELL = NICKEL

**ELECTRICAL:**  
 RF ATTENUATION = 10 kHz TO 400MHz @ >30 dBs  
 IN GENERAL ACCORDANCE WITH MIL STD 1377 (1971)  
 CURRENT RATING AT 25°C = 3.0A MAX  
 CURRENT RATING AT 85°C = 2.2A MAX  
 WORKING VOLTAGE = 120V AC/DC  
 VOLTAGE PROOF = 360V AC/DC  
 CONTACT RESISTANCE = 25 mΩ MAX  
 INSULATION RESISTANCE = 100 MΩ MIN

**MECHANICAL:**  
 DURABILITY = 500 OPERATIONS

**ENVIRONMENTAL:**  
 TEMPERATURE RANGE = -55°C TO +121°C

**PACKING:**  
 SEE NOTES

FOR COMPLETE SPECIFICATION, SEE COMPONENT SPECIFICATION C005XX (LATEST ISSUE) AND C042XX (LATEST ISSUE)

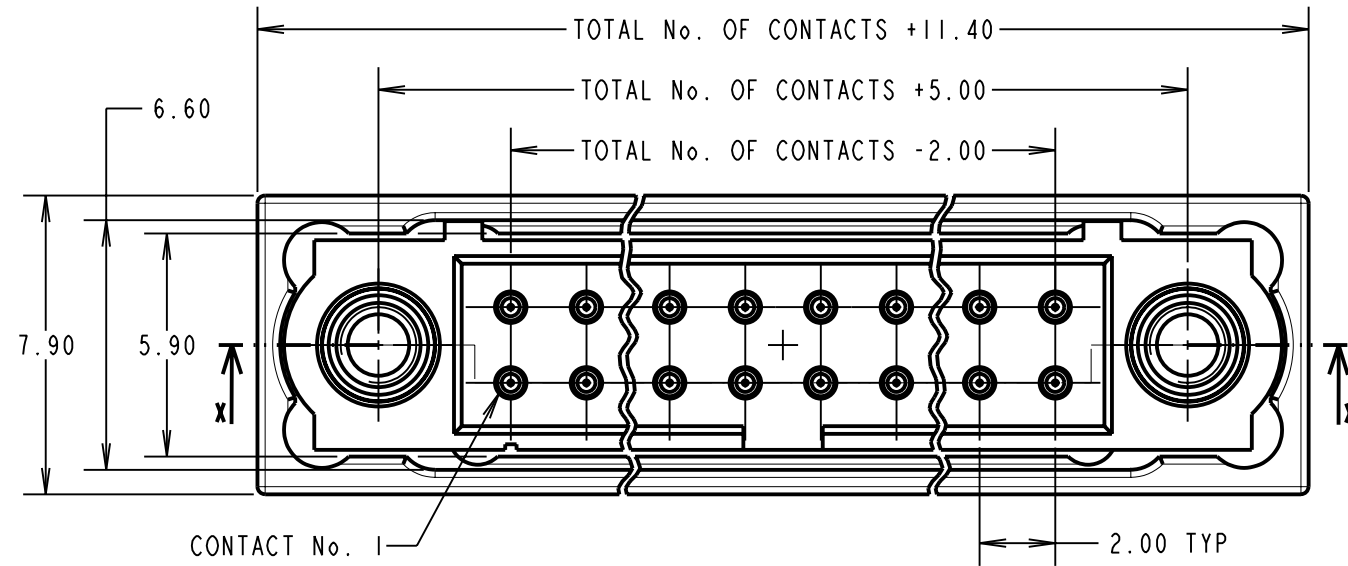

**NOTES:**

- SUPPLIED AS A KIT OF PARTS, CONNECTORS SHOWN ASSEMBLED FOR INFORMATION PURPOSES ONLY.
- CONNECTORS WITH JACKSCREWS ASSEMBLED, SLOTTED NUTS AND CONTACTS WILL BE SUPPLIED LOOSE IN A BAG, BACKSHELLS WILL BE INDIVIDUALLY BAGGED. KITS WILL BE BULK PACKED INTO BOXES
- FOR EXTRA CONTACTS, USE PART No: M80-1950005 FOR M80-5C1XX05B1
- FOR M80-5C1XX05B1 RECOMMENDED WIRE TYPE = BS 3G 210 TYPE A, PTFE INSULATED 24-28 AWG. MAX INSULATION DIAMETER = Ø1.10mm, STRIP WIRE BY 2.00mm.
- RECOMMENDED HAND CRIMP TOOL FOR ALL CONTACTS = M22520/2-01 WITH POSITIONER Z80-193
- CONTACT INSERTION AND EXTRACTION TOOL = Z80-280.
- INSTRUCTION SHEETS ARE AVAILABLE.

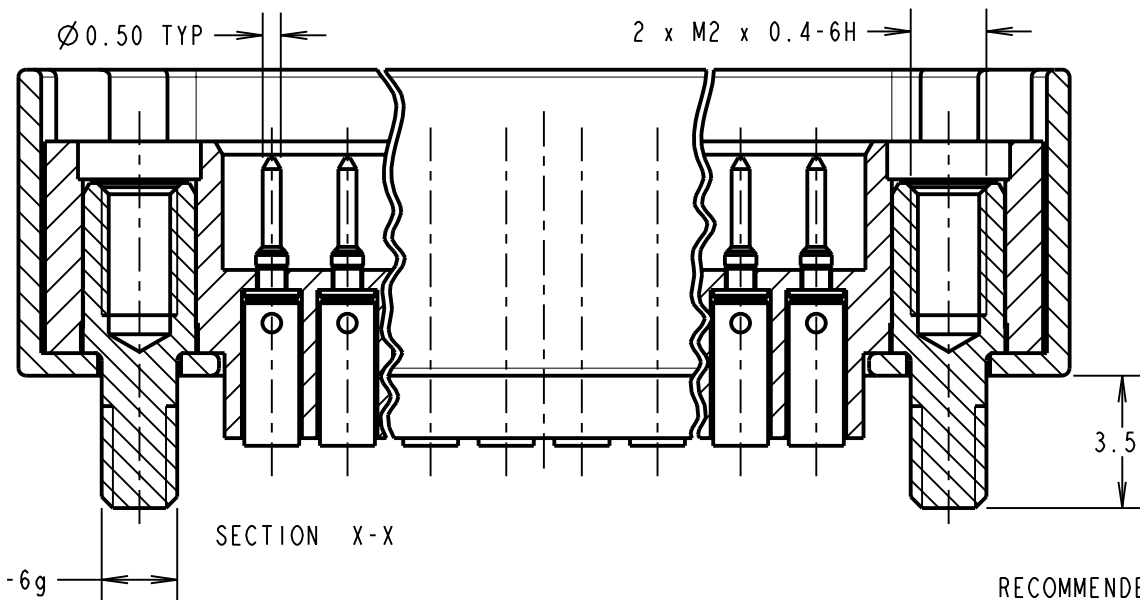
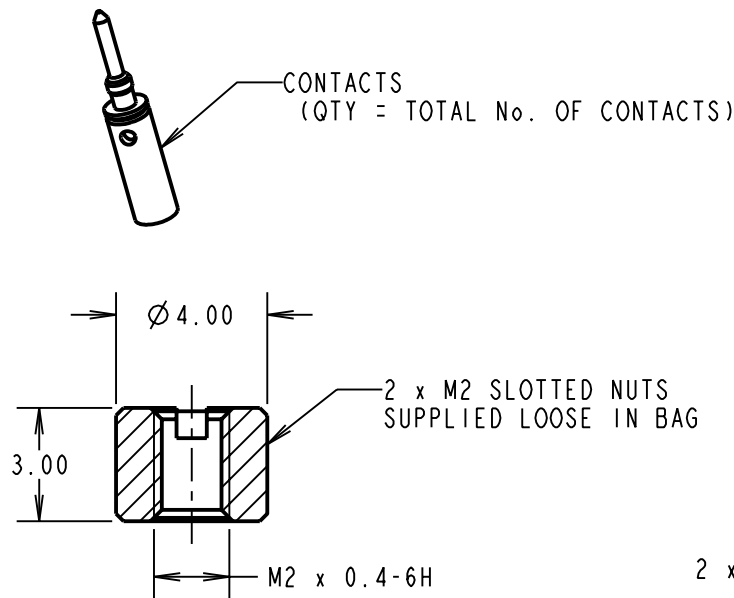

**RECOMMENDED PCB LAYOUT**

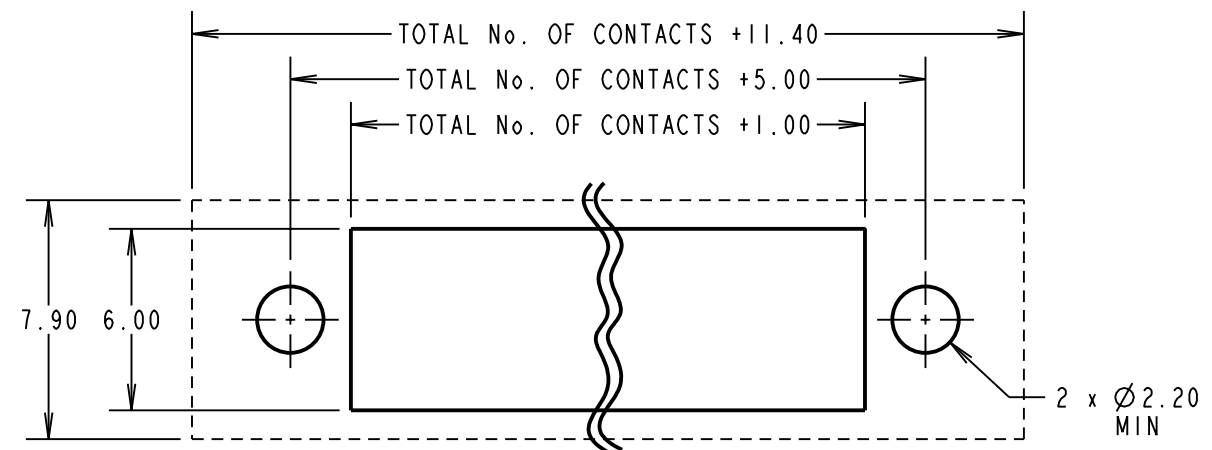

ORDER CODE: **M80-5C1XXXXB1**

TOTAL No. OF CONTACTS  
06, 10, 14, 20, 26

FINISH CODE  
05 - ALL OVER GOLD

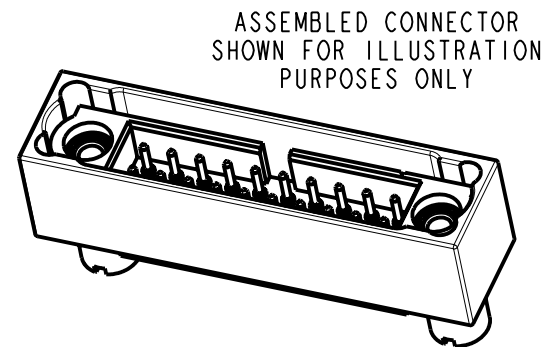

SB	4	14.03.11	11172
NAME	ISS.	DATE	C/NOTE
APPROVED: S.BENNETT			
CHECKED: S.FLOWER			
DRAWN: S.FLOWER			
CUSTOMER REF.:			
ASSEMBLY DRG:			

EXAMPLE ORDER CODE: CONNECTOR WITH 20 SMALL BORE CONTACTS, ALL OVER GOLD CONTACT.

**M80-5C12005B1**

**HARWIN**

HARWIN USA  
TEL: 603 893 5376  
FAX: 603 893 5396  
mis@harwin.com

HARWIN Europe (UK)  
TEL: 023 9231 4545  
FAX: 023 9231 4590  
mis@harwin.co.uk

HARWIN Asia  
TEL: +65 6 779 4909  
FAX: +65 6 779 3868  
mis@harwin.com.sg

THIS DRAWING AND ANY INFORMATION OR DESCRIPTIVE MATTER SET OUT HEREON ARE CONFIDENTIAL AND COPYRIGHT PROPERTY OF THE HARWIN GROUP AND MUST NOT BE DISCLOSED, LOANED, COPIED OR USED FOR MANUFACTURING, TENDERING OR FOR ANY OTHER PURPOSE WITHOUT THEIR WRITTEN PERMISSION.

**TOLERANCES**  
 X. = ±1mm  
 X.X = ±0.25mm  
 X.XX = ±0.10mm  
 X.XXX = ±0.01mm  
 ANGLES = ±5°  
 UNLESS STATED

**MATERIAL:**  
 SEE ABOVE

**FINISH:**  
 SEE ABOVE

**S/AREA:**  
 mm<sup>2</sup>

**TITLE:** DATAMATE J-TEK DIL MALE CRIMP (SMALL BORE) ASSY WITH METAL BACKSHELL

**DRAWING NUMBER:** M80-5C1XXXXB1

SHT 2 OF 2