



Chipsmall Limited consists of a professional team with an average of over 10 year of expertise in the distribution of electronic components. Based in Hongkong, we have already established firm and mutual-benefit business relationships with customers from,Europe,America and south Asia,supplying obsolete and hard-to-find components to meet their specific needs.

With the principle of "Quality Parts,Customers Priority,Honest Operation,and Considerate Service",our business mainly focus on the distribution of electronic components. Line cards we deal with include Microchip,ALPS,ROHM,Xilinx,Pulse,ON,Everlight and Freescale. Main products comprise IC,Modules,Potentiometer,IC Socket,Relay,Connector.Our parts cover such applications as commercial,industrial, and automotives areas.

We are looking forward to setting up business relationship with you and hope to provide you with the best service and solution. Let us make a better world for our industry!



Contact us

Tel: +86-755-8981 8866 Fax: +86-755-8427 6832

Email & Skype: info@chipsmall.com Web: www.chipsmall.com

Address: A1208, Overseas Decoration Building, #122 Zhenhua RD., Futian, Shenzhen, China



Customer Information Sheet

DRAWING No.: M80-845XXXX

IF IN DOUBT - ASK

©

NOT TO SCALE

THIRD ANGLE PROJECTION

ALL DIMENSIONS IN mm

SPECIFICATIONS:

MATERIAL:

MOULDING = HIGH TEMP. POLYAMIDE 46,
UL94V-0, BLACK

CLIP = BERYLLIUM COPPER

SHELL = COPPER ALLOY

FINISH:

42 = 0.30µ GOLD CLIP, 4.0µ 100% TIN
OVER NICKEL SHELL

45 = 0.30µ GOLD CLIP, 0.28µ GOLD SHELL

ELECTRICAL:

CURRENT RATING AT 25°C = 3.0A MAX

CURRENT RATING AT 85°C = 2.2A MAX

WORKING VOLTAGE = 120V AC/DC

VOLTAGE PROOF = 360V AC/DC

CONTACT RESISTANCE:

INITIAL = 25mΩ MAX

AFTER CONDITIONING = 20mΩ MAX

INSULATION RESISTANCE:

INITIAL = 1000MΩ MIN

AFTER CONDITIONING = 100MΩ MIN

ENVIRONMENTAL:

TEMPERATURE RANGE = -55°C TO +125°C

MECHANICAL:

DURABILITY = 500 OPERATIONS

INSERTION FORCE = 2.8N MAX, 1.0N MIN

WITHDRAWAL FORCE = 1.8N MAX, 0.2N MIN

PACKING:

BAGS (CONNECTOR SUPPLIED UN-ASSEMBLED)
FOR COMPLETE SPECIFICATION, SEE COMPONENT
SPECIFICATION C005XX (LATEST ISSUE)

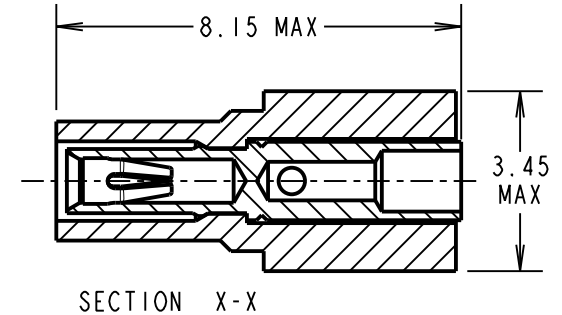
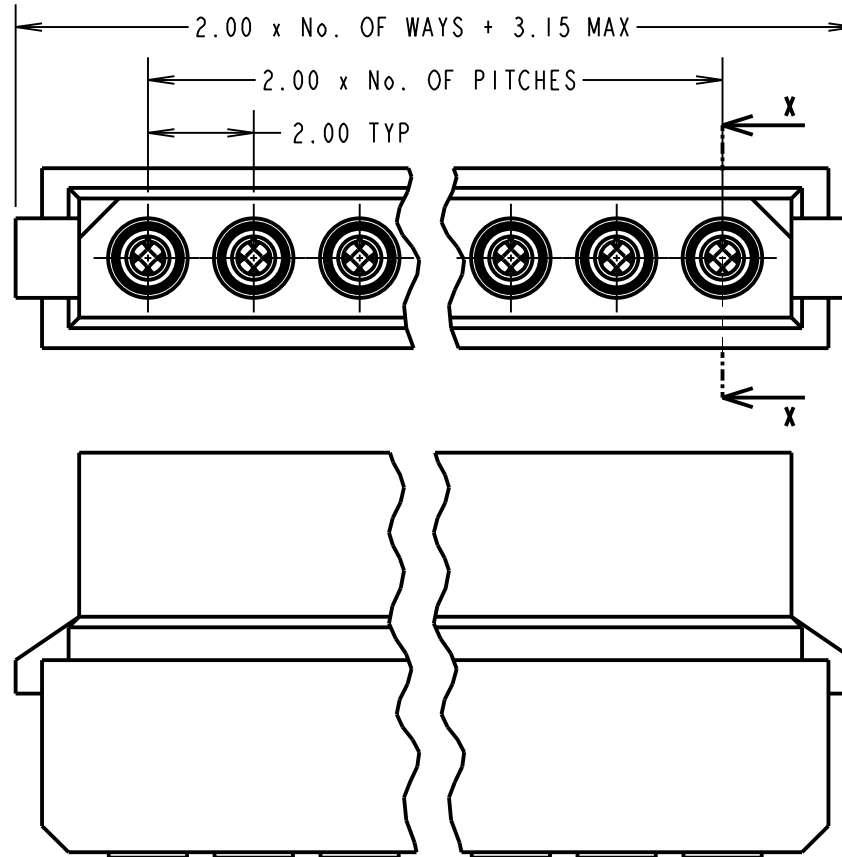

SECTION X-X

ORDER CODE:

M80-845XXXX

TOTAL No. OF WAYS _____

02 - 07, 17

FINISH: _____

42 - GOLD CLIP, 100% TIN SHELL

45 - GOLD CLIP, GOLD SHELL

NOTES:

1. RECOMMENDED WIRE TYPE = BS3G210 TYPE A, PTFE INSULATED 24 - 28AWG. MAX INSULATION DIAMETER = Ø1.10mm. STRIP WIRE BY 2.00mm.
2. RECOMMENDED HAND CRIMP TOOL = M22520/2-01 WITH POSITIONER T5747. SEE TOOLING INSTRUCTION SHEET IS-01 FOR COMPLETE CRIMPING INSTRUCTIONS.
3. CONTACT INSERTION AND EXTRACTION TOOL = Z80-280. REFER TO INSTRUCTION SHEET IS-25 FOR ASSEMBLY INSTRUCTIONS.

SM	4	08.08.11	11389
NAME	ISS.	DATE	C/NOTE
APPROVED: S. MCCULLAGH			
CHECKED:		R. ADDE	
DRAWN: W. J. BOURNE			
CUSTOMER REF.:			
ASSEMBLY DRG:			

HARWIN

HARWIN USA
TEL: 603 893 5376
FAX: 603 893 5396
mis@harwin.com

HARWIN Europe (UK)
TEL: 023 9231 4545
FAX: 023 9231 4590
mis@harwin.co.uk

HARWIN Asia
TEL: +65 6 779 4909
FAX: +65 6 779 3868
mis@harwin.com.sg

THIS DRAWING AND ANY INFORMATION OR DESCRIPTIVE MATTER SET OUT HEREON ARE CONFIDENTIAL AND COPYRIGHT PROPERTY OF THE HARWIN GROUP AND MUST NOT BE DISCLOSED, LOANED, COPIED OR USED FOR MANUFACTURING, TENDERING OR FOR ANY OTHER PURPOSE WITHOUT THEIR WRITTEN PERMISSION.

TOLERANCES

X. = ±1mm
X.X = ±0.25mm
X.XX = ±0.10mm
X.XXX = ±0.01mm

ANGLES = ±5°

UNLESS STATED

MATERIAL:

SEE ABOVE

FINISH: SEE ABOVE

S/AREA:

mm²

TITLE:

DATAMATE CRIMP
SIL SOCKET ASSEMBLY
SMALL BORE (24 - 28 AWG)

DRAWING NUMBER:

M80-845XXXX

SHT

2 OF 2