



Chipsmall Limited consists of a professional team with an average of over 10 year of expertise in the distribution of electronic components. Based in Hongkong, we have already established firm and mutual-benefit business relationships with customers from,Europe,America and south Asia,supplying obsolete and hard-to-find components to meet their specific needs.

With the principle of "Quality Parts,Customers Priority,Honest Operation,and Considerate Service",our business mainly focus on the distribution of electronic components. Line cards we deal with include Microchip,ALPS,ROHM,Xilinx,Pulse,ON,Everlight and Freescale. Main products comprise IC,Modules,Potentiometer,IC Socket,Relay,Connector.Our parts cover such applications as commercial,industrial, and automotives areas.

We are looking forward to setting up business relationship with you and hope to provide you with the best service and solution. Let us make a better world for our industry!



Contact us

Tel: +86-755-8981 8866 Fax: +86-755-8427 6832

Email & Skype: info@chipsmall.com Web: www.chipsmall.com

Address: A1208, Overseas Decoration Building, #122 Zhenhua RD., Futian, Shenzhen, China



SPECIFICATION

- Part No. : **MA.203W.A.A301111.B301111**
- Product Name : GPS/Penta-band Cellular Adhesive Antenna
- Feature : High gain LNA up to 32dB
(GSM/CDMA/PCS/DCS/UMTS/GPRS/EDGE/ HSPA)
Height 10.8mm Diameter 55.1mm
Waterproof IP67 Version
RoHS Compliant



3D view



top view
(this side faces the sky)



underside view
(this side faces the passenger)

I. Introduction

This is a combination high performance GPS and Penta-band Cellular (GSM/CDMA/PCS/DCS/ / UMTS / GPRS / EDGE/ HSPA) antenna to simplify AVL or Fleet management antenna systems worldwide. Its high quality low profile covert housing can be attached onto the glass or even out of sight under the dashboard. This combination of a high gain GPS antenna and a leading edge penta band cellular antenna is ideal for those applications that require durability, small size and covert installation, and reliable reception and transmission crossing through different mobile networks.

Features

GPS

- High LNA Gain up to 32 dB
- Antenna Gain 30 ± 2 dB
- Miniaturized to 55.15x12mm
- Low Noise 1.5 dB max

Cellular

- Advanced penta-band cellular antenna (GSM/CDMA/PCS/DCS/UMTS/GPRS/EDGE/HSPA)

Other

- Water Resistant IP 67
- Quality textured covert design. Low profile
- UV resistant ABS housing
- Comes with high grade 3M double sided tape for quick and easy mounting
- Optional cables and connectors

II. Specification

Performance Specifications		
Items	GPS Patch Antenna	Cellular Antenna
Features	High performance GPS ceramic patch antenna with cutting edge low noise amplifier	CDMA:824~896MHz DCS: 1710~1880MHz PCS: 1850~1990MHz GSM: 880~960MHz
Centre Frequency	1593MHz ± 2MHz(Free Space)	As above
Gain	-3.0dB typ.	As patterns
	Axial Ratio :2.0 dB max	
Polarization	RHCP	-
Bandwidth	10 MHz min	-
VSWR	1.92 Max.	-
Impedance	50Ω	50Ω
Cable / Connector	Standard 1/2/3/5/10mRG-174 Cables and Connectors Fully Customizable	Standard 1/2/3/5/10mRG-174 Cables and Connectors Fully Customizable
Return Loss	-	10dB Typ
Size	59.8mm * 16mm	
Housing	UV resistant ABS	

*note: specifications may be subject to change

LNA GPS Antenna

Parameter	Specification
Frequency	1575.42 ± 1.023MHz
Gain	28dB Typical
Output Impedance	50Ω
Output VSWR	1.92 Max
DC Power Input	2.7-3.3V
Noise Figure	1.5dB Typ.
Power Consumption	6mA

III. GPS Ceramic Patch Antenna Free Space



With Housing, Glass Mount

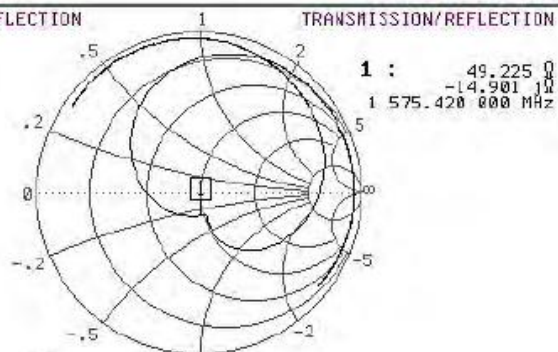
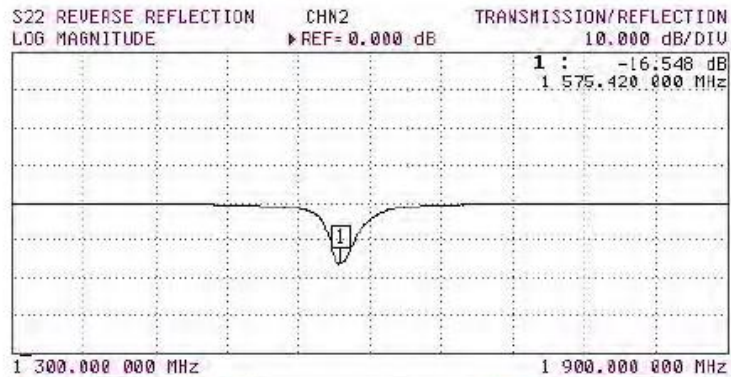

IV. GSM Radiation Patterns

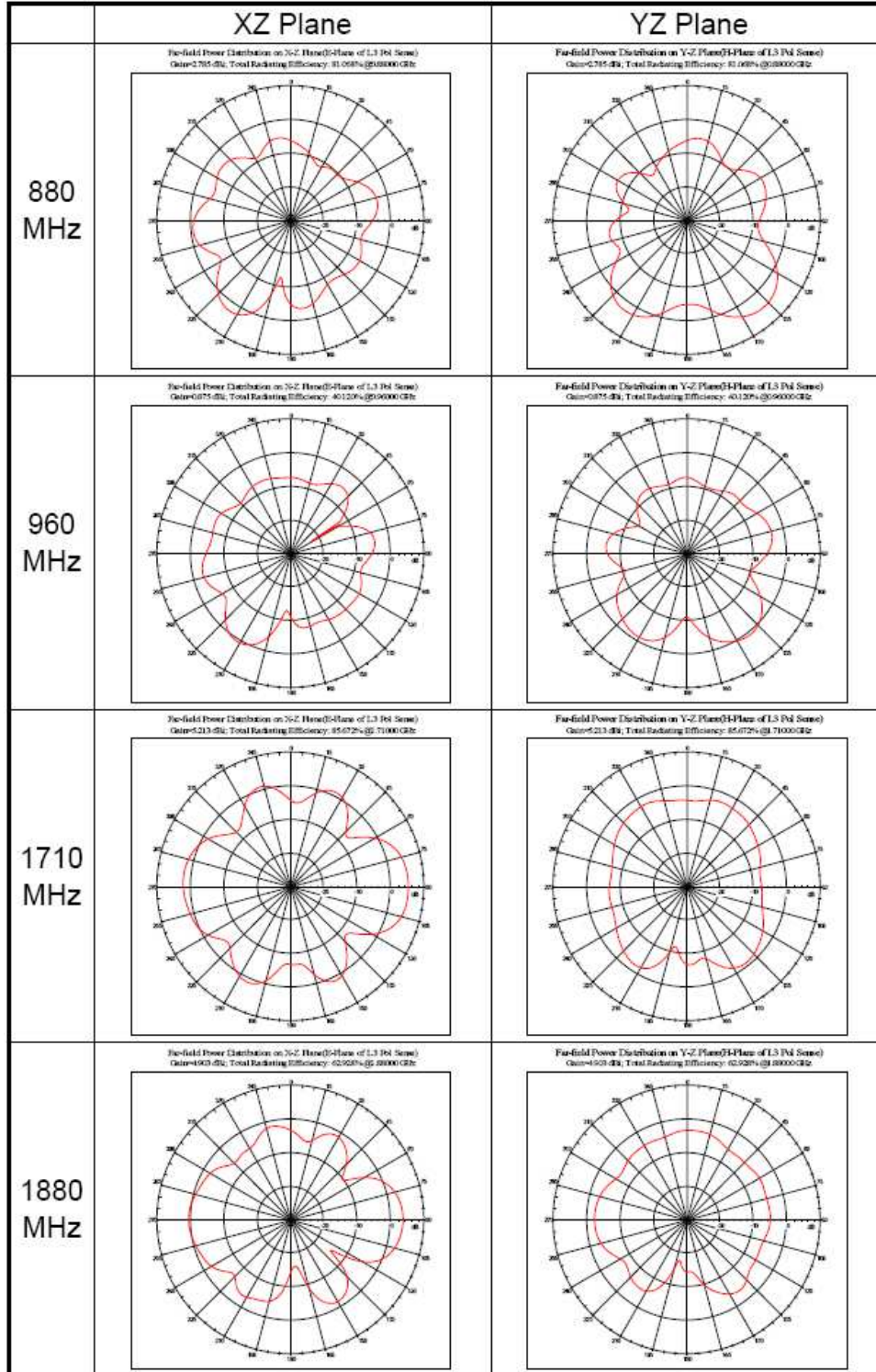

V. GSM Antenna Return Loss

Free Space

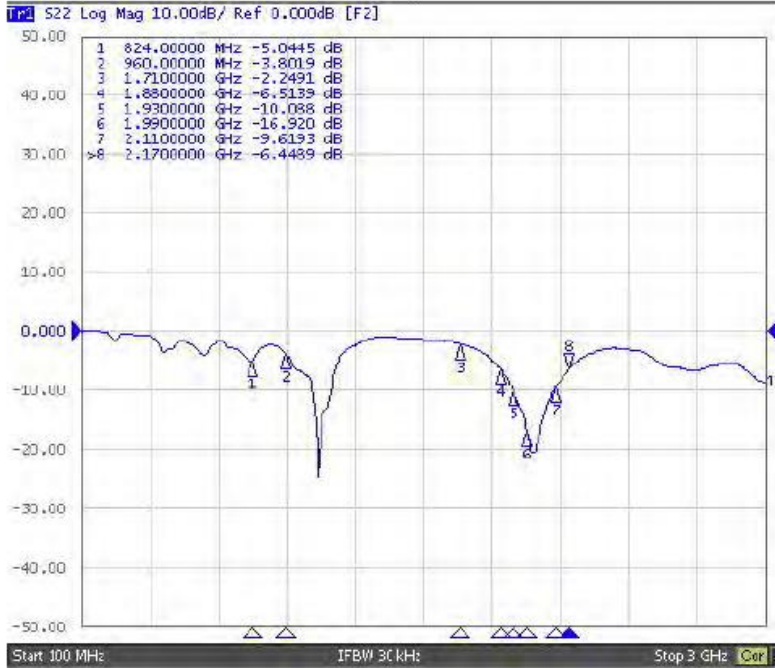

With Housing, Glass Mount

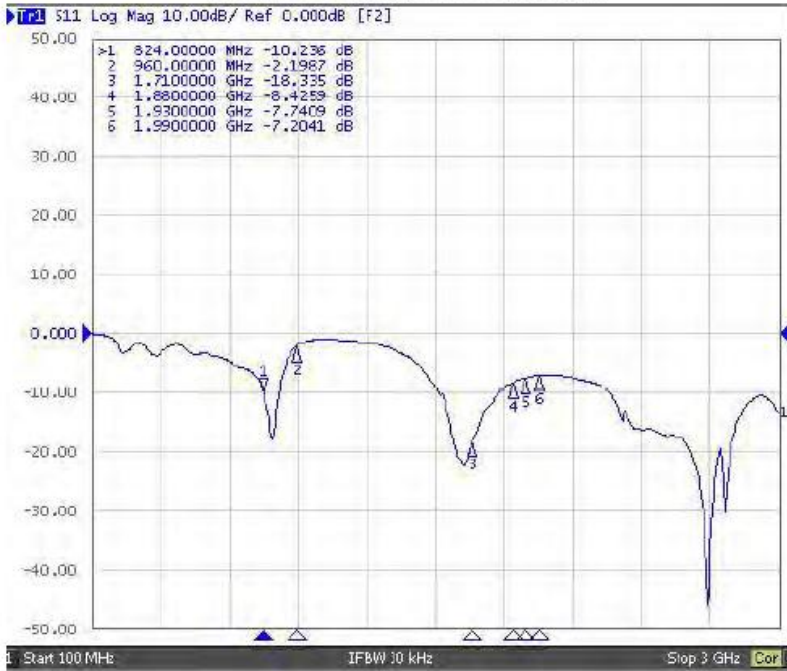

VI. Drawings

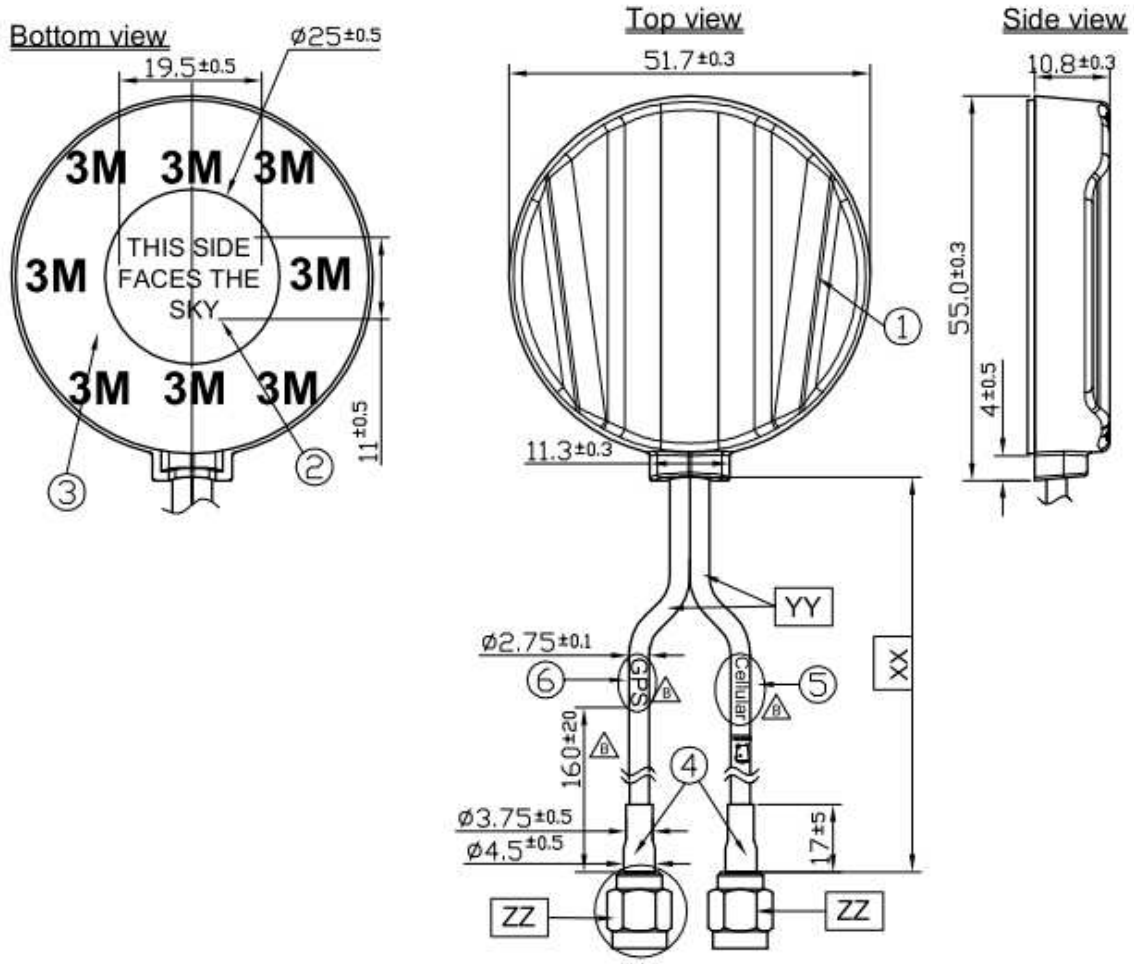

SMA(M) ST

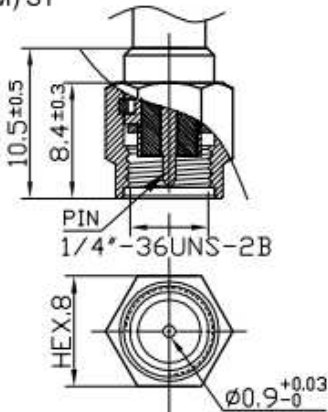

	Name	P/N	Material	Finish	QTY
1	Housing	000111I0200XXA	ABS	Black	1
2	Round Label	001011I0100XXA	Art Paper	White	1
3	Scotch Brand Acrylic Foam Tape	001011I0200XXA	3M 4612	White Liner	1
4	Heat Shrink tube	001311F0000XXA	PE	Black	2
5	Cellular Label	001011F0200XXA	Coated Paper	Blue	1
6	GPS Label	001011F0000XXA	Coated Paper	Orange	1
	Name	P/N	Spec	Finish	QTY
XX	Cable Length		3000mm ± 30 mm		1
YY	Cable Type	301311F0000XXA	RG174	Black	2
ZZ	Connector Type	200211L000015A	SMA(M) ST	Gold	2

VII. Packaging

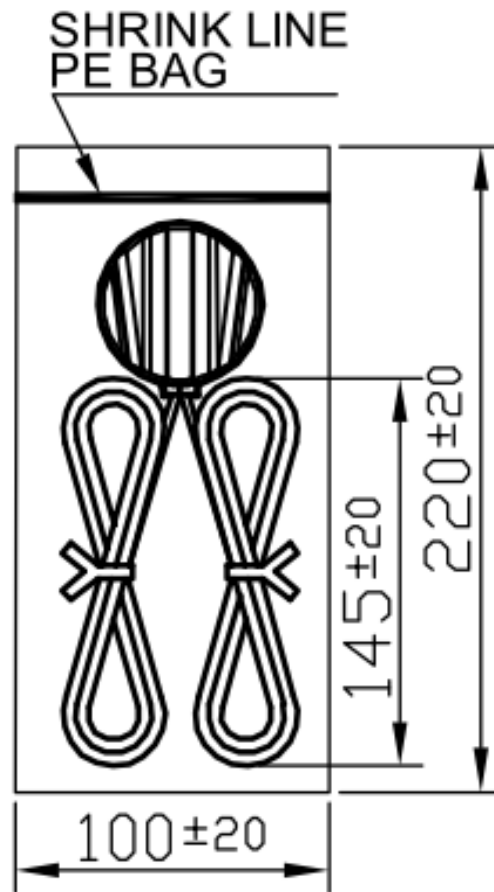

PACKING:1PCS/BAG