



Chipsmall Limited consists of a professional team with an average of over 10 year of expertise in the distribution of electronic components. Based in Hongkong, we have already established firm and mutual-benefit business relationships with customers from,Europe,America and south Asia,supplying obsolete and hard-to-find components to meet their specific needs.

With the principle of “Quality Parts,Customers Priority,Honest Operation,and Considerate Service”,our business mainly focus on the distribution of electronic components. Line cards we deal with include Microchip,ALPS,ROHM,Xilinx,Pulse,ON,Everlight and Freescale. Main products comprise IC,Modules,Potentiometer,IC Socket,Relay,Connector.Our parts cover such applications as commercial,industrial, and automotives areas.

We are looking forward to setting up business relationship with you and hope to provide you with the best service and solution. Let us make a better world for our industry!



Contact us

Tel: +86-755-8981 8866 Fax: +86-755-8427 6832

Email & Skype: info@chipsmall.com Web: www.chipsmall.com

Address: A1208, Overseas Decoration Building, #122 Zhenhua RD., Futian, Shenzhen, China





PIC32MX270F512L

PIC32MX270F512L Bluetooth® Audio 100-pin to 100-pin TQFP Plug-In Module (PIM) Information Sheet

The PIC32MX270F512L Bluetooth Audio PIM is designed to demonstrate the capabilities of the PIC32MX1XX/2XX/5XX family of devices using the PIC32 Bluetooth Audio Development Kit board.

Note: This PIM can only be used with the PIC32 Bluetooth Audio Development Board. To get started with development, please visit: <http://www.microchip.com/pic32tools> and click the PIC32 Bluetooth Audio Development Board product link.

The PIC32MX1XX/2XX/5XX family of devices are low cost, high-performance 32-bit microcontrollers that can perform a wide variety of functionality for embedded applications.

Table 1 shows the mapping between the development board functions and the device pins.

TABLE 1: 100-PIN TO 100-PIN PIM

Device Pin #	PIC32MX270F512L Functional Description	PIM Pin #
1	AN28/RG15	1
2	VDD	2
3	AN22/RPE5/PMD5/RE5	3
4	AN23/PMD6/RE6	4
5	AN27/PMD7/RE7	5
6	AN29/RPC1/RC1	6
7	AN30/RPC2/RC2	7
8	AN31/RPC3/RC3	8
9	RPC4/CTED7/RC4	9
10	AN16/C1IND/RPG6/SCK2/PMA5/RG6	10
11	AN17/C1INC/RPG7/PMA4/RG7	11
12	AN18/C2IND/RPG8/PMA3/RG8	12
13	MCLR	13
14	AN19/C2INC/RPG9/PMA2/RG9	14
15	VSS	15
16	VDD	16
17	TMS/CTED1/RA0	17
18	AN32/RPE8/RE8	18
19	AN33/RPE9/RE9	19
20	AN5/C1INA/RPB5/VBUSON/RB5	20
21	AN4/C1INB/USBOEN/RB4	21
22	PGED3/AN3/C2INA/RPB3/RB3	22
23	PGEC3/AN2/CTCMP/C2INB/RPB2/CTED13/RB2	23
24	PGEC1/AN1/RPB1/CTED12/RB1	24
25	PGED1/AN0/RPB0/RB0	25
26	PGEC2/AN6/RPB6/RB6	26
27	PGED2/AN7/RPB7/CTED3/RB7	27
28	VREF-/PMA7/RA9	28
29	VREF+/PMA6/RA10	29
30	AVDD	30
31	AVSS	31
32	AN8/RPB8/CTED10/RB8	32
33	AN9/RPB9/CTED4/RB9	33
34	CVREFOUT/AN10/RPB10/CTED11/PMA13/RB10	34

Device Pin #	PIC32MX270F512L Functional Description	PIM Pin #
35	AN11/PMA12/RB11	35
36	VSS	36
37	VDD	37
38	TCK/CTED2/RA1	38
39	AN34/RPF13/SCK3/RF13	39
40	AN35/RPF12/RF12	40
41	AN12/PMA11/RB12	41
42	AN13/PMA10/RB13	42
43	AN14/RPB14/CTED5/PMA1/RB14	43
44	AN15/RPB15/OCFB/CTED6/PMA0/RB15	44
45	VSS	45
46	VDD	46
47	AN36/RPD14/RD14	47
48	AN37/RPD15/SCK4/RD15	48
49	RPF4/PMA9/RF4	49
50	RPF5/PMA8/RF5	50
51	USBID/RPF3/RF3	51
52	AN38/RPF2/RF2	52
53	AN39/RPF8/RF8	53
54	VBUS	54
55	VUSB3V3	55
56	D-	56
57	D+	57
58	SCL2/RA2	58
59	SDA2/RA3	59
60	TDI/CTED9/RA4	60
61	TDO/RA5	61
62	VDD	62
63	OSC1/CLKI/RC12	63
64	OSC2/CLKO/RC15	64
65	VSS	65
66	RPA14/SCL1/RA14	66
67	RPA15/SDA1/RA15	67
68	RPD8/RTCC/RD8	68

PIC32MX270F512L

TABLE 1: 100-PIN TO 100-PIN PIM (CONTINUED)

Device Pin #	PIC32MX270F512L Functional Description	PIM Pin #	Device Pin #	PIC32MX270F512L Functional Description	PIM Pin #
69	RPD9/RD9	69	85	VCAP	85
70	RPD10/SCK1/PMA15/RD10	70	86	VDD	86
71	RPD11/PMA14/RD11	71	87	AN44/C3INA/RPF0/PMD11/RF0	87
72	RPD0/INT0/RD0	72	88	AN45/RPF1/PMD10/RF1	88
73	SOSCI/RPC13/RC13	73	89	RPG1/PMD9/RG1	89
74	SOSCO/RPC14/T1CK/RC14	74	90	RPG0/PMD8/RG0	90
75	Vss	75	91	TRCLK/RA6	91
76	AN24/RPD1/RD1	76	92	TRD3/CTED8/RA7	92
77	AN25/RPD2/RD2	77	93	AN46/PMD0/RE0	93
78	AN26/C3IND/RPD3/RD3	78	94	AN47/PMD1/RE1	94
79	AN40/RPD12/PMD12/RD12	79	95	TRD2/RG14	95
80	AN41/PMD13/RD13	80	96	TRD1/RG12	96
81	RPD4/PMWR/RD4	81	97	TRD0/RG13	97
82	RPD5/PMRD/RD5	82	98	AN20/PMD2/RE2	98
83	AN42/C3INC/PMD14/RD6	83	99	RPE3/CTPLS/PMD3/RE3	99
84	AN43/C3INB/PMD15/RD7	84	100	AN21/PMD4/RE4	100

FIGURE 1: 100-PIN PIM SOCKET AND DEVICE SCHEMATIC

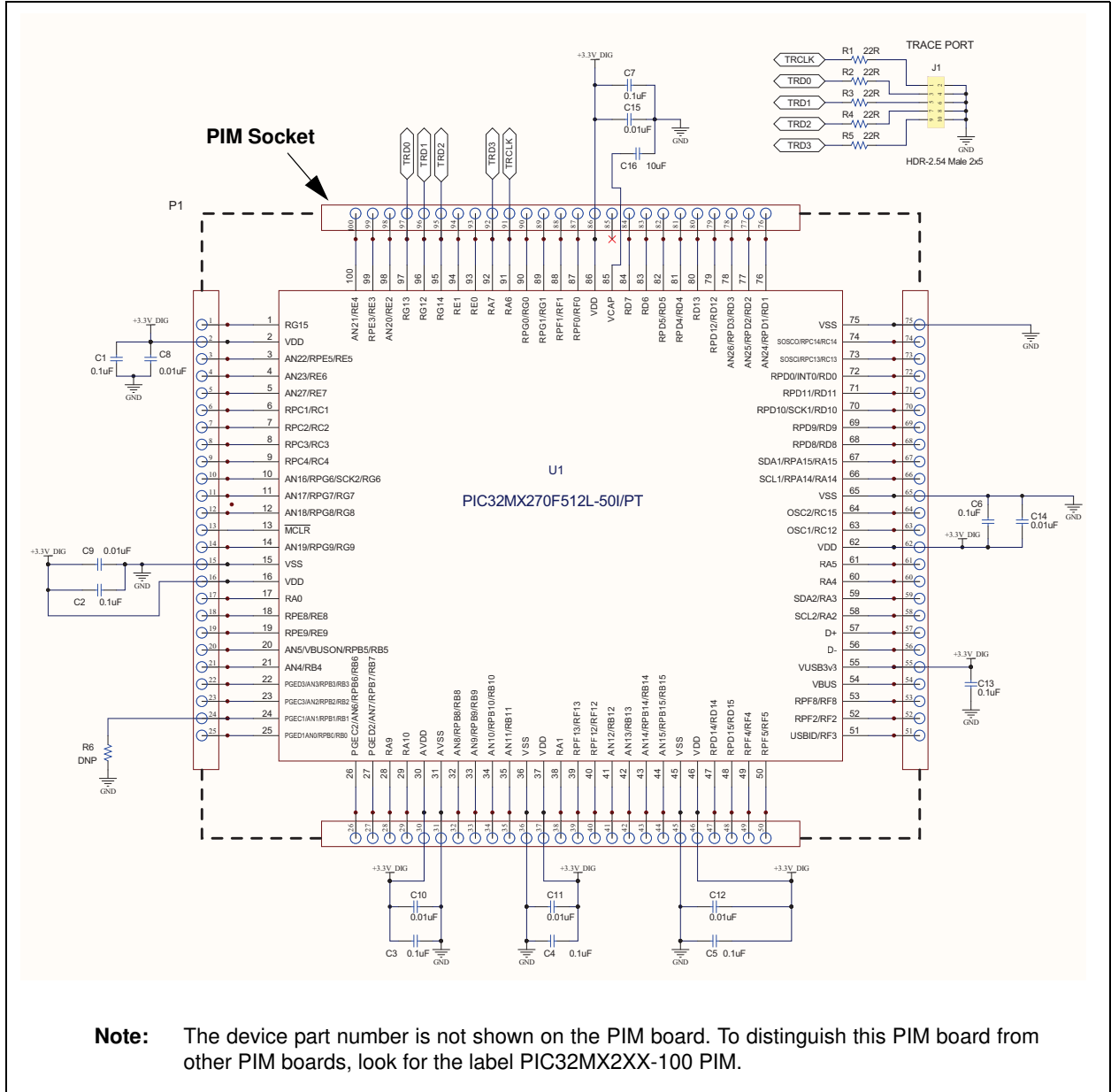

Note: The device part number is not shown on the PIM board. To distinguish this PIM board from other PIM boards, look for the label PIC32MX2XX-100 PIM.

PIC32MX270F512L

REVISION HISTORY

Revision A (October 2014)

This is the initial released version of this document.

Note the following details of the code protection feature on Microchip devices:

- Microchip products meet the specification contained in their particular Microchip Data Sheet.
- Microchip believes that its family of products is one of the most secure families of its kind on the market today, when used in the intended manner and under normal conditions.
- There are dishonest and possibly illegal methods used to breach the code protection feature. All of these methods, to our knowledge, require using the Microchip products in a manner outside the operating specifications contained in Microchip's Data Sheets. Most likely, the person doing so is engaged in theft of intellectual property.
- Microchip is willing to work with the customer who is concerned about the integrity of their code.
- Neither Microchip nor any other semiconductor manufacturer can guarantee the security of their code. Code protection does not mean that we are guaranteeing the product as "unbreakable."

Code protection is constantly evolving. We at Microchip are committed to continuously improving the code protection features of our products. Attempts to break Microchip's code protection feature may be a violation of the Digital Millennium Copyright Act. If such acts allow unauthorized access to your software or other copyrighted work, you may have a right to sue for relief under that Act.

Information contained in this publication regarding device applications and the like is provided only for your convenience and may be superseded by updates. It is your responsibility to ensure that your application meets with your specifications. MICROCHIP MAKES NO REPRESENTATIONS OR WARRANTIES OF ANY KIND WHETHER EXPRESS OR IMPLIED, WRITTEN OR ORAL, STATUTORY OR OTHERWISE, RELATED TO THE INFORMATION, INCLUDING BUT NOT LIMITED TO ITS CONDITION, QUALITY, PERFORMANCE, MERCHANTABILITY OR FITNESS FOR PURPOSE. Microchip disclaims all liability arising from this information and its use. Use of Microchip devices in life support and/or safety applications is entirely at the buyer's risk, and the buyer agrees to defend, indemnify and hold harmless Microchip from any and all damages, claims, suits, or expenses resulting from such use. No licenses are conveyed, implicitly or otherwise, under any Microchip intellectual property rights.

Trademarks

The Microchip name and logo, the Microchip logo, dsPIC, FlashFlex, flexPWR, JukeBlox, KEELOQ, KEELOQ logo, Kleer, LANCheck, MediaLB, MOST, MOST logo, MPLAB, OptoLyzer, PIC, PICSTART, PIC³² logo, RightTouch, SpyNIC, SST, SST Logo, SuperFlash and UNI/O are registered trademarks of Microchip Technology Incorporated in the U.S.A. and other countries.

The Embedded Control Solutions Company and mTouch are registered trademarks of Microchip Technology Incorporated in the U.S.A.

Analog-for-the-Digital Age, BodyCom, chipKIT, chipKIT logo, CodeGuard, dsPICDEM, dsPICDEM.net, ECAN, In-Circuit Serial Programming, ICSP, Inter-Chip Connectivity, KleerNet, KleerNet logo, MiWi, MPASM, MPF, MPLAB Certified logo, MPLIB, MPLINK, MultiTRAK, NetDetach, Omniscient Code Generation, PICDEM, PICDEM.net, PICkit, PICtail, RightTouch logo, REAL ICE, SQI, Serial Quad I/O, Total Endurance, TSHARC, USBCheck, VariSense, ViewSpan, WiperLock, Wireless DNA, and ZENA are trademarks of Microchip Technology Incorporated in the U.S.A. and other countries.

SQTP is a service mark of Microchip Technology Incorporated in the U.S.A.

Silicon Storage Technology is a registered trademark of Microchip Technology Inc. in other countries.

GestIC is a registered trademarks of Microchip Technology Germany II GmbH & Co. KG, a subsidiary of Microchip Technology Inc., in other countries.

All other trademarks mentioned herein are property of their respective companies.

© 2014, Microchip Technology Incorporated, Printed in the U.S.A., All Rights Reserved.

ISBN: 978-1-63276-715-8

**QUALITY MANAGEMENT SYSTEM
CERTIFIED BY DNV
= ISO/TS 16949 =**

Microchip received ISO/TS-16949:2009 certification for its worldwide headquarters, design and wafer fabrication facilities in Chandler and Tempe, Arizona; Gresham, Oregon and design centers in California and India. The Company's quality system processes and procedures are for its PIC[®] MCUs and dsPIC[®] DSCs, KEELOQ[®] code hopping devices, Serial EEPROMs, microperipherals, nonvolatile memory and analog products. In addition, Microchip's quality system for the design and manufacture of development systems is ISO 9001:2000 certified.



MICROCHIP

Worldwide Sales and Service

AMERICAS

Corporate Office
2355 West Chandler Blvd.
Chandler, AZ 85224-6199
Tel: 480-792-7200
Fax: 480-792-7277
Technical Support:
[http://www.microchip.com/
support](http://www.microchip.com/support)
Web Address:
www.microchip.com

Atlanta
Duluth, GA
Tel: 678-957-9614
Fax: 678-957-1455

Austin, TX
Tel: 512-257-3370

Boston
Westborough, MA
Tel: 774-760-0087
Fax: 774-760-0088

Chicago
Itasca, IL
Tel: 630-285-0071
Fax: 630-285-0075

Cleveland
Independence, OH
Tel: 216-447-0464
Fax: 216-447-0643

Dallas
Addison, TX
Tel: 972-818-7423
Fax: 972-818-2924

Detroit
Novi, MI
Tel: 248-848-4000

Houston, TX
Tel: 281-894-5983

Indianapolis
Noblesville, IN
Tel: 317-773-8323
Fax: 317-773-5453

Los Angeles
Mission Viejo, CA
Tel: 949-462-9523
Fax: 949-462-9608

New York, NY
Tel: 631-435-6000

San Jose, CA
Tel: 408-735-9110

Canada - Toronto
Tel: 905-673-0699
Fax: 905-673-6509

ASIA/PACIFIC

Asia Pacific Office
Suites 3707-14, 37th Floor
Tower 6, The Gateway
Harbour City, Kowloon
Hong Kong
Tel: 852-2943-5100
Fax: 852-2401-3431

Australia - Sydney
Tel: 61-2-9868-6733
Fax: 61-2-9868-6755

China - Beijing
Tel: 86-10-8569-7000
Fax: 86-10-8528-2104

China - Chengdu
Tel: 86-28-8665-5511
Fax: 86-28-8665-7889

China - Chongqing
Tel: 86-23-8980-9588
Fax: 86-23-8980-9500

China - Hangzhou
Tel: 86-571-8792-8115
Fax: 86-571-8792-8116

China - Hong Kong SAR
Tel: 852-2943-5100
Fax: 852-2401-3431

China - Nanjing
Tel: 86-25-8473-2460
Fax: 86-25-8473-2470

China - Qingdao
Tel: 86-532-8502-7355
Fax: 86-532-8502-7205

China - Shanghai
Tel: 86-21-5407-5533
Fax: 86-21-5407-5066

China - Shenyang
Tel: 86-24-2334-2829
Fax: 86-24-2334-2393

China - Shenzhen
Tel: 86-755-8864-2200
Fax: 86-755-8203-1760

China - Wuhan
Tel: 86-27-5980-5300
Fax: 86-27-5980-5118

China - Xian
Tel: 86-29-8833-7252
Fax: 86-29-8833-7256

China - Xiamen
Tel: 86-592-2388138
Fax: 86-592-2388130

China - Zhuhai
Tel: 86-756-3210040
Fax: 86-756-3210049

ASIA/PACIFIC

India - Bangalore
Tel: 91-80-3090-4444
Fax: 91-80-3090-4123

India - New Delhi
Tel: 91-11-4160-8631
Fax: 91-11-4160-8632

India - Pune
Tel: 91-20-3019-1500

Japan - Osaka
Tel: 81-6-6152-7160
Fax: 81-6-6152-9310

Japan - Tokyo
Tel: 81-3-6880-3770
Fax: 81-3-6880-3771

Korea - Daegu
Tel: 82-53-744-4301
Fax: 82-53-744-4302

Korea - Seoul
Tel: 82-2-554-7200
Fax: 82-2-558-5932 or
82-2-558-5934

Malaysia - Kuala Lumpur
Tel: 60-3-6201-9857
Fax: 60-3-6201-9859

Malaysia - Penang
Tel: 60-4-227-8870
Fax: 60-4-227-4068

Philippines - Manila
Tel: 63-2-634-9065
Fax: 63-2-634-9069

Singapore
Tel: 65-6334-8870
Fax: 65-6334-8850

Taiwan - Hsin Chu
Tel: 886-3-5778-366
Fax: 886-3-5770-955

Taiwan - Kaohsiung
Tel: 886-7-213-7830

Taiwan - Taipei
Tel: 886-2-2508-8600
Fax: 886-2-2508-0102

Thailand - Bangkok
Tel: 66-2-694-1351
Fax: 66-2-694-1350

EUROPE

Austria - Wels
Tel: 43-7242-2244-39
Fax: 43-7242-2244-393

Denmark - Copenhagen
Tel: 45-4450-2828
Fax: 45-4485-2829

France - Paris
Tel: 33-1-69-53-63-20
Fax: 33-1-69-30-90-79

Germany - Dusseldorf
Tel: 49-2129-3766400

Germany - Munich
Tel: 49-89-627-144-0
Fax: 49-89-627-144-44

Germany - Pforzheim
Tel: 49-7231-424750

Italy - Milan
Tel: 39-0331-742611
Fax: 39-0331-466781

Italy - Venice
Tel: 39-049-7625286

Netherlands - Druenen
Tel: 31-416-690399
Fax: 31-416-690340

Poland - Warsaw
Tel: 48-22-3325737

Spain - Madrid
Tel: 34-91-708-08-90
Fax: 34-91-708-08-91

Sweden - Stockholm
Tel: 46-8-5090-4654

UK - Wokingham
Tel: 44-118-921-5800
Fax: 44-118-921-5820

03/25/14