



Chipsmall Limited consists of a professional team with an average of over 10 year of expertise in the distribution of electronic components. Based in Hongkong, we have already established firm and mutual-benefit business relationships with customers from,Europe,America and south Asia,supplying obsolete and hard-to-find components to meet their specific needs.

With the principle of “Quality Parts,Customers Priority,Honest Operation,and Considerate Service”,our business mainly focus on the distribution of electronic components. Line cards we deal with include Microchip,ALPS,ROHM,Xilinx,Pulse,ON,Everlight and Freescale. Main products comprise IC,Modules,Potentiometer,IC Socket,Relay,Connector.Our parts cover such applications as commercial,industrial, and automotives areas.

We are looking forward to setting up business relationship with you and hope to provide you with the best service and solution. Let us make a better world for our industry!



Contact us

Tel: +86-755-8981 8866 Fax: +86-755-8427 6832

Email & Skype: info@chipsmall.com Web: www.chipsmall.com

Address: A1208, Overseas Decoration Building, #122 Zhenhua RD., Futian, Shenzhen, China



PIC32MK 100-pin Motor Control Plug-In Module (PIM) Information Sheet

The PIC32MK 100-pin Motor Control Plug-in Module (PIM) (MA320024) is designed to demonstrate the capabilities of PIC32MK 100-pin Motor Control devices using external or internal on-chip op amps with the following hardware:

- dsPICDEM™ MCLV-2 Development Board (DM330021-2)
- dsPICDEM™ MCHV-2 Development Board (DM330023-2)
- dsPICDEM™ MCHV-3 Development Board (DM330023-3)

All three development boards support 100-pin PIM interfaces. For example, the PIC32MK1024MCF100 is a 32-bit Motor control microcontroller in a 100-pin TQFP package that can be used with all three boards.

Selecting the External On-board Op Amp Configuration

To operate the PIC32MK 100-pin Motor Control PIM using external on-board op amps, insert the External Op amp Configuration Board, which is included with the development board, into the appropriate header for the hardware in use:

- J14 (dsPICDEM MCLV-2 Development Board)
- J4 (dsPICDEM MCHV-2/MCHV-3 Development Board). In addition, for the MCHV-2/MCHV-3, ensure that jumpers are set at position 1-2 for J12, J13, J14, and position 5-6 for J11.

Figure 1 shows the connection location for the external on-board op amp on the dsPICDEM MCLV-2 Development Board.

FIGURE 1: EXTERNAL OP AMP CONFIGURATION BOARD



Selecting the Internal On-board Op Amp Configuration

To operate the PIC32MK 100-pin Motor Control PIM using internal on-chip Op Amps, insert the Internal Op Amp Configuration Board, which is included with the development board, into the appropriate header for the hardware in use:

- J14 (dsPICDEM MCLV-2 Development Board)
- J4 (dsPICDEM MCHV-2/MCHV-3 Development Board)

Figure 2 shows the connection location for the internal on-board op amp on the dsPICDEM MCLV-2 Development Board.

FIGURE 2: INTERNAL OP AMP CONFIGURATION BOARD



WARNING: Do not connect non-isolated oscilloscope probes to probe any traces while using the PIM with the dsPICDEM MCHV-2 or dsPICDEM MCHV-3 Development Boards. Instead, use a high-voltage differential probe, rate in excess of 600 VRMS (Common mode). Failure to heed this warning could result in hardware damage.

Table 1 provides the static mapping between the 100-pin PIM pins and the 100-pin device pins.

Figure 3 shows the 100-pin PIM header schematic.

Figure 4 shows the 100-pin PIM device schematic.

PIC32MK

TABLE 1: 100-PIN DEVICE TO 100-PIN PIM MAPPING

Device Pin Number	PIC32MK 100-pin Device Functional Description	PIM Pin Number	Device Pin Number	PIC32MK 100-pin Device Functional Description	PIM Pin Number
1	RG15	1	51	AN24	25
2	VDD	2	52	RPE0 (C1TX)	77, 88
3	RPA7 (U3TX)	51, 76	53	AN41/RPE1 (INDX2)	43
4	PWM1H	94	54	VBus	—
5	PWM1L	93	55	VBUS3V3	62
6	PWM5L	4	56	D1-	—
7	PWM5H	71	57	D1+	—
8	PWM6L	6	58	VBus2	53
9	PWM6H	7	59	D2-	54
10	RPG6 (HOME2)	61	60	D2+	55
11	AN18	29	61	RF5	60
12	AN17/RPG8 (QEB2)	42	62	VDD	62
13	MCLR	13	63	CLKI	—
14	AN16/RPG9 (QEA2)	41	64	RC15	64
15	VSS	15	65	VSS	65
16	VDD	16	66	RPA14 (INDX2)	48
17	AN22	8	67	RPA15 (U3RX)	52, 72
18	AN21	9	68	RD8	68
19	AN20	79	69	PGED2	27
20	AN10	35	70	PGEC2	26
21	AN9	24	71	DAC2	H
22	OA2OUT	D2	72	AN25	23
23	OA2IN+ (INDX2)	F2	73	RPC13	91
24	OA2IN-	E2	74	RPB8	92
25	OA1OUT	D1	75	VSS	75
26	OA1IN+ (QEB2)	F1	76	RPB9 (U2TX)	50
27	OA1IN-	E1	77	USBID2	56
28	VREF-	—	78	RC7	84
29	VREF+	28	79	RD12	69
30	AVDD	30	80	RD13	58
31	AVSS	31	81	RPC8 (U2RX)	49, 70
32	OA3OUT	D3	82	RD5	82
33	OA3IN-	E3	83	RD6	—
34	OA3IN+ (QEA2)	F3	84	RPC9	80
35	RC11	33	85	VSS	85
36	VSS	36	86	VDD	86
37	VDD	37	87	RPF0 (C1RX)	78, 87
38	RG11	34	88	RF1	89
39	AN36	38	89	RG1	83
40	AN37	69	90	RG0	90
41	AN12	40	91	RF6	59
42	FLT6	19	92	RF7	—
43	RPE14 (QEB2)	47	93	PWM3H	3
44	AN15	32	94	PWM3L	100
45	VSS	45	95	RG14	95
46	VDD	46	96	RG12	96
47	RD14	44	97	RG13	97
48	RD15	—	98	PWM2H	99
49	DAC3	85	99	PWM2L	98
50	FLT15	18	100	TDO	—

FIGURE 3: 100-PIN PIM HEADER SCHEMATIC

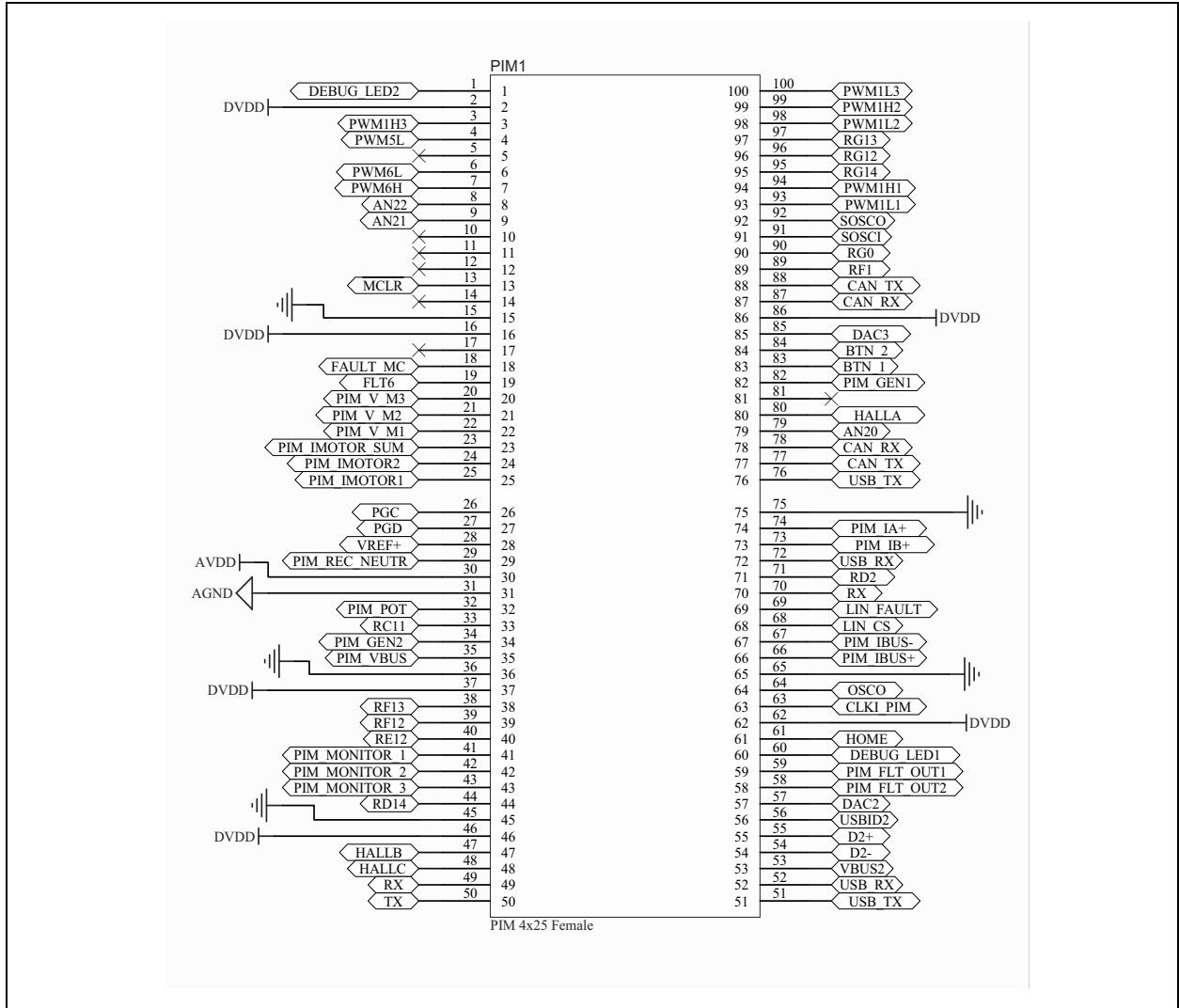
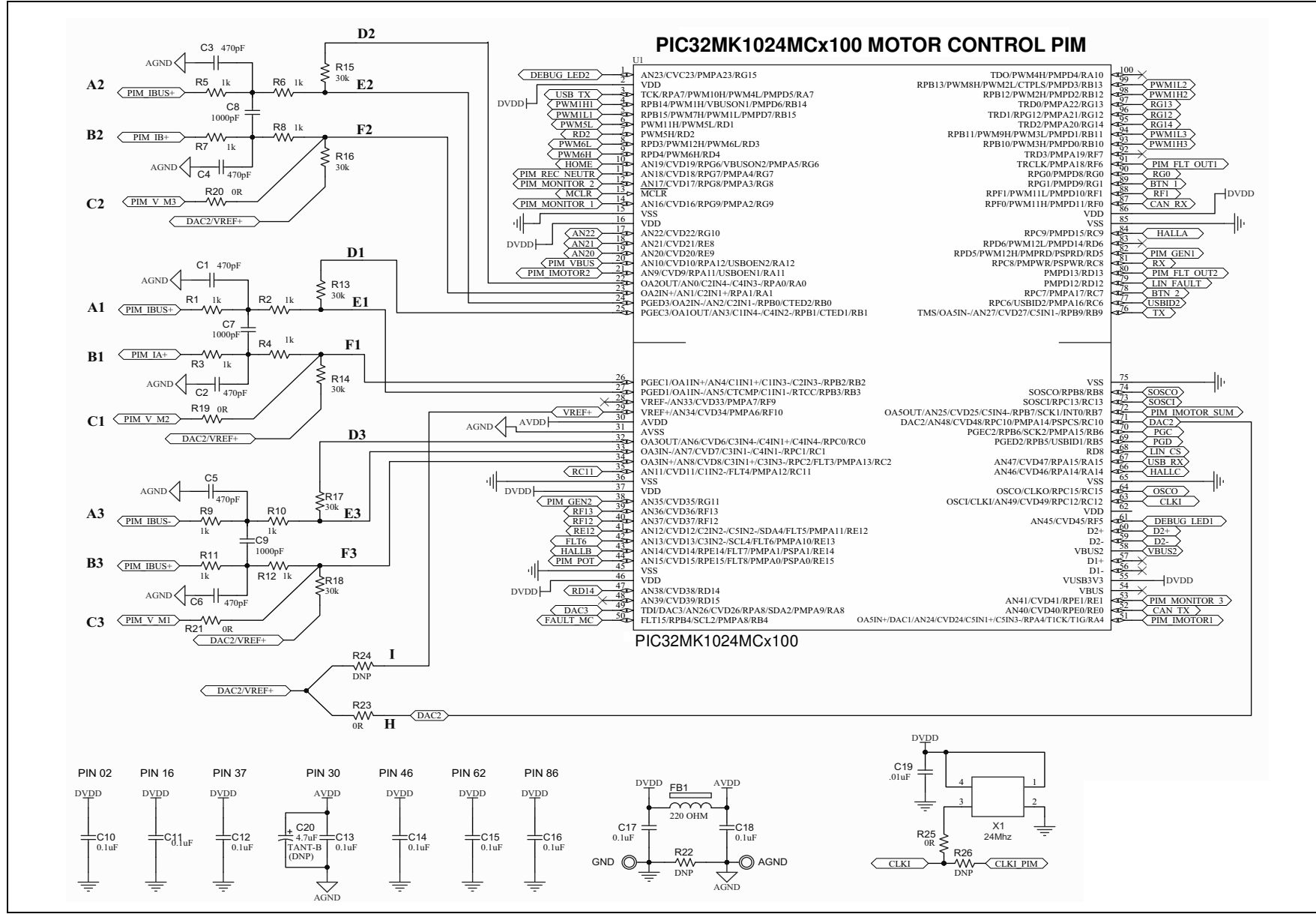

FIGURE 4: 100-PIN PIM DEVICE SCHEMATIC



The reference voltage (VREF) biases the op amps to VDD/2 so that bidirectional motor phase current can be sensed using unipolar op amps. The source of VREF can be selected either from the development board or from the internally generated reference voltage using DAC2 and resistors R23/R24, as shown in Figure 4. By default, the PIM is configured to source the reference voltage, internally generated using DAC2 by populating R23 and keeping R24 depopulated.

To source the reference voltage from Motor Control PIM, R23 needs to be depopulated and R24 must be populated with a zero ohm resistor.

The internal op amp configuration and passive resistor-capacitive network configures the filter bandwidth, op amp bias and op amp gain, as shown in Figure 4.

Table 2 classifies the passive components according to their functionality and also specifies the design equations for filter bandwidth and op amp gain.

TABLE 2: ANALOG FUNCTIONALITY LISTING

Op Amp Number	Analog Function	Passive Components	Design Equations
1	Low-Pass Filter	R1, R2, R3, R4, C1, C2, C7	$R1 \quad R2 \quad R3 \quad R4 \quad R$ $C1 \quad C2 \quad C$
	Differential Amplifier Input	R1, R2, R3, R4	
	Differential Amplifier Feedback	R13	$Common\ mode\ f_{-3dB} \cong \frac{1}{2\pi RC}$ $Differential\ mode\ f_{-3dB} \cong \frac{1}{2\pi(2R)\left(\frac{C}{2} \quad C_7\right)}$ $Differential\ Amplifier\ Gain \quad \frac{R_{13}}{2R}$
2	Low-Pass Filter	R5, R6, R7, R8, C3, C4, C8	$R5 \quad R6 \quad R7 \quad R8 \quad R$ $C3 \quad C4 \quad C$
	Differential Amplifier Input	R5, R6, R7, R8	
	Differential Amplifier Feedback	R15	$Common\ mode\ f_{-3dB} \cong \frac{1}{2\pi RC}$ $Differential\ mode\ f_{-3dB} \cong \frac{1}{2\pi(2R)\left(\frac{C}{2} \quad C_8\right)}$ $Differential\ Amplifier\ Gain \quad \frac{R_{15}}{2R}$
3	Low-Pass Filter	R9, R10, R11, R12, C5, C6, C9	$R9 \quad R10 \quad R11 \quad R12 \quad R$ $C5 \quad C6 \quad C$
	Differential Amplifier Input	R9, R10, R11, R12	
	Differential Amplifier Feedback	R17	$Common\ mode\ f_{-3dB} \cong \frac{1}{2\pi RC}$ $Differential\ mode\ f_{-3dB} \cong \frac{1}{2\pi(2R)\left(\frac{C}{2} \quad C_9\right)}$ $Differential\ Amplifier\ Gain \quad \frac{R_{17}}{2R}$

Figure 5 illustrates a typical block diagram of the op amp circuit.

FIGURE 5: OP AMP CIRCUIT BLOCK DIAGRAM

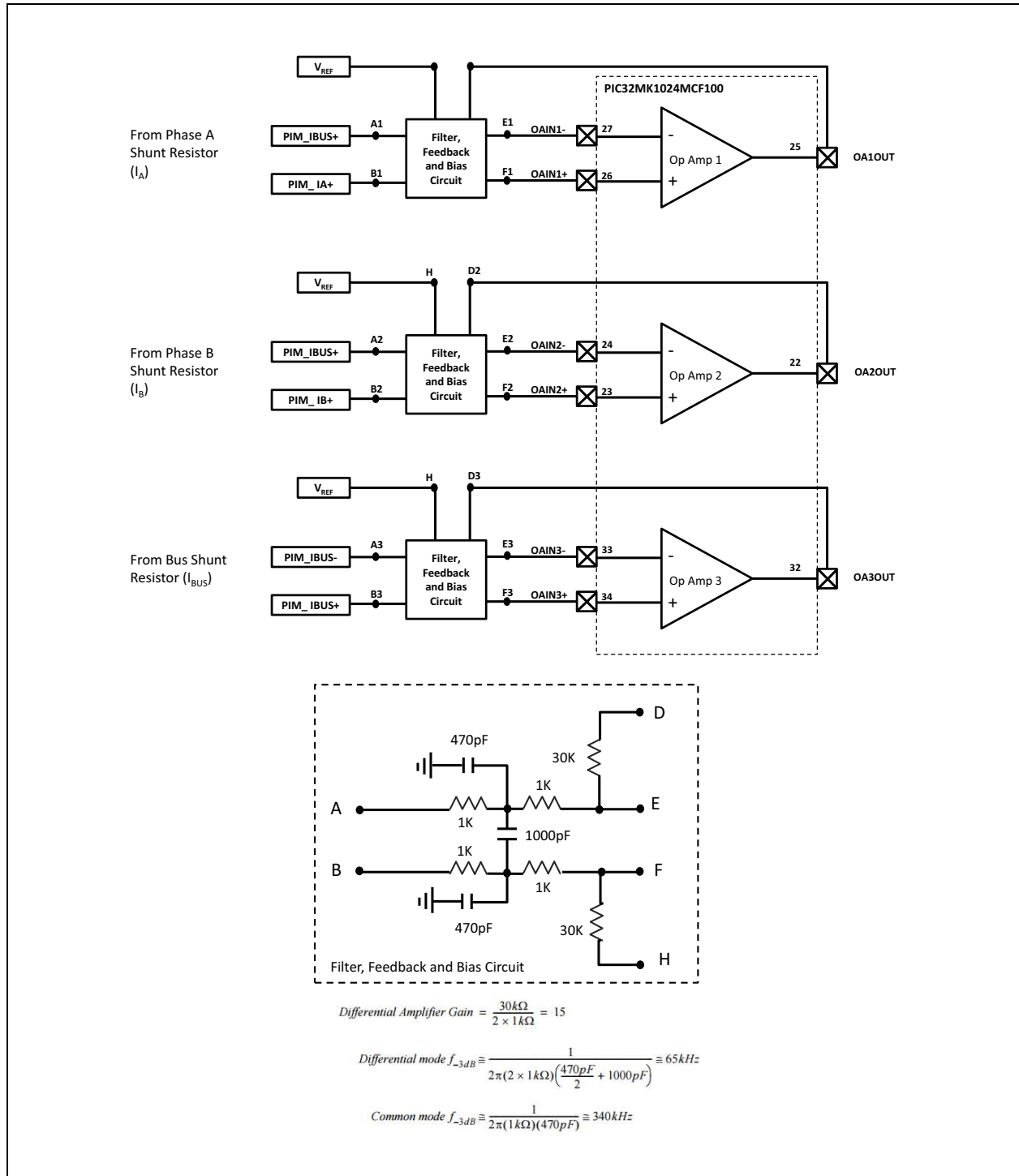

Note the following details of the code protection feature on Microchip devices:

- Microchip products meet the specification contained in their particular 2017 DS50002613B Microchip Data Sheet.
- Microchip believes that its family of products is one of the most secure families of its kind on the market today, when used in the intended manner and under normal conditions.
- There are dishonest and possibly illegal methods used to breach the code protection feature. All of these methods, to our knowledge, require using the Microchip products in a manner outside the operating specifications contained in Microchip's Data Sheets. Most likely, the person doing so is engaged in theft of intellectual property.
- Microchip is willing to work with the customer who is concerned about the integrity of their code.
- Neither Microchip nor any other semiconductor manufacturer can guarantee the security of their code. Code protection does not mean that we are guaranteeing the product as "unbreakable."

Code protection is constantly evolving. We at Microchip are committed to continuously improving the code protection features of our products. Attempts to break Microchip's code protection feature may be a violation of the Digital Millennium Copyright Act. If such acts allow unauthorized access to your software or other copyrighted work, you may have a right to sue for relief under that Act.

Information contained in this publication regarding device applications and the like is provided only for your convenience and may be superseded by updates. It is your responsibility to ensure that your application meets with your specifications. MICROCHIP MAKES NO REPRESENTATIONS OR WARRANTIES OF ANY KIND WHETHER EXPRESS OR IMPLIED, WRITTEN OR ORAL, STATUTORY OR OTHERWISE, RELATED TO THE INFORMATION, INCLUDING BUT NOT LIMITED TO ITS CONDITION, QUALITY, PERFORMANCE, MERCHANTABILITY OR FITNESS FOR PURPOSE. Microchip disclaims all liability arising from this information and its use. Use of Microchip devices in life support and/or safety applications is entirely at the buyer's risk, and the buyer agrees to defend, indemnify and hold harmless Microchip from any and all damages, claims, suits, or expenses resulting from such use. No licenses are conveyed, implicitly or otherwise, under any Microchip intellectual property rights unless otherwise stated.

Microchip received ISO/TS-16949:2009 certification for its worldwide headquarters, design and wafer fabrication facilities in Chandler and Tempe, Arizona; Gresham, Oregon and design centers in California and India. The Company's quality system processes and procedures are for its PIC® MCUs and dsPIC® DSCs, KEELOQ® code hopping devices, Serial EEPROMs, microperipherals, nonvolatile memory and analog products. In addition, Microchip's quality system for the design and manufacture of development systems is ISO 9001:2000 certified.

**QUALITY MANAGEMENT SYSTEM
CERTIFIED BY DNV
= ISO/TS 16949 =**

Trademarks

The Microchip name and logo, the Microchip logo, AnyRate, AVR, AVR logo, AVR Freaks, BeaconThings, BitCloud, CryptoMemory, CryptoRF, dsPIC, FlashFlex, flexPWR, Heldo, JukeBlox, KEELOQ, KEELOQ logo, Kleer, LANCheck, LINK MD, maXStylus, maXTouch, MediaLB, megaAVR, MOST, MOST logo, MPLAB, OptoLyzer, PIC, picoPower, PICSTART, PIC32 logo, Prochip Designer, QTouch, RightTouch, SAM-BA, SpyNIC, SST, SST Logo, SuperFlash, tinyAVR, UNI/O, and XMEGA are registered trademarks of Microchip Technology Incorporated in the U.S.A. and other countries.

ClockWorks, The Embedded Control Solutions Company, EtherSynch, Hyper Speed Control, HyperLight Load, IntellIMOS, mTouch, Precision Edge, and Quiet-Wire are registered trademarks of Microchip Technology Incorporated in the U.S.A.

Adjacent Key Suppression, AKS, Analog-for-the-Digital Age, Any Capacitor, AnyIn, AnyOut, BodyCom, chipKIT, chipKIT logo, CodeGuard, CryptoAuthentication, CryptoCompanion, CryptoController, dsPICDEM, dsPICDEM.net, Dynamic Average Matching, DAM, ECAN, EtherGREEN, In-Circuit Serial Programming, ICSP, Inter-Chip Connectivity, JitterBlocker, KleerNet, KleerNet logo, Mindi, MiWi, motorBench, MPASM, MPF, MPLAB Certified logo, MPLIB, MPLINK, MultiTRAK, NetDetach, Omniscient Code Generation, PICDEM, PICDEM.net, PICKit, PICtail, PureSilicon, QMatrix, RightTouch logo, REAL ICE, Ripple Blocker, SAM-ICE, Serial Quad I/O, SMART-I.S., SQI, SuperSwitcher, SuperSwitcher II, Total Endurance, TSHARC, USBCheck, VariSense, ViewSpan, WiperLock, Wireless DNA, and ZENA are trademarks of Microchip Technology Incorporated in the U.S.A. and other countries.

SQTP is a service mark of Microchip Technology Incorporated in the U.S.A.

Silicon Storage Technology is a registered trademark of Microchip Technology Inc. in other countries.

GestIC is a registered trademark of Microchip Technology Germany II GmbH & Co. KG, a subsidiary of Microchip Technology Inc., in other countries.

All other trademarks mentioned herein are property of their respective companies.

© 2017, Microchip Technology Incorporated, All Rights Reserved.
ISBN: 978-1-5224-2320-1



MICROCHIP

Worldwide Sales and Service

AMERICAS

Corporate Office
2355 West Chandler Blvd.
Chandler, AZ 85224-6199
Tel: 480-792-7200
Fax: 480-792-7277
Technical Support:
<http://www.microchip.com/support>
Web Address:
www.microchip.com

Atlanta
Duluth, GA
Tel: 678-957-9614
Fax: 678-957-1455

Austin, TX
Tel: 512-257-3370

Boston
Westborough, MA
Tel: 774-760-0087
Fax: 774-760-0088

Chicago
Itasca, IL
Tel: 630-285-0071
Fax: 630-285-0075

Dallas
Addison, TX
Tel: 972-818-7423
Fax: 972-818-2924

Detroit
Novi, MI
Tel: 248-848-4000

Houston, TX
Tel: 281-894-5983

Indianapolis
Noblesville, IN
Tel: 317-773-8323
Fax: 317-773-5453
Tel: 317-536-2380

Los Angeles
Mission Viejo, CA
Tel: 949-462-9523
Fax: 949-462-9608
Tel: 951-273-7800

Raleigh, NC
Tel: 919-844-7510

New York, NY
Tel: 631-435-6000

San Jose, CA
Tel: 408-735-9110
Tel: 408-436-4270

Canada - Toronto
Tel: 905-695-1980
Fax: 905-695-2078

ASIA/PACIFIC

Australia - Sydney
Tel: 61-2-9868-6733

China - Beijing
Tel: 86-10-8569-7000

China - Chengdu
Tel: 86-28-8665-5511

China - Chongqing
Tel: 86-23-8980-9588

China - Dongguan
Tel: 86-769-8702-9880

China - Guangzhou
Tel: 86-20-8755-8029

China - Hangzhou
Tel: 86-571-8792-8115

China - Hong Kong SAR
Tel: 852-2943-5100

China - Nanjing
Tel: 86-25-8473-2460

China - Qingdao
Tel: 86-532-8502-7355

China - Shanghai
Tel: 86-21-3326-8000

China - Shenyang
Tel: 86-24-2334-2829

China - Shenzhen
Tel: 86-755-8864-2200

China - Suzhou
Tel: 86-186-6233-1526

China - Wuhan
Tel: 86-27-5980-5300

China - Xian
Tel: 86-29-8833-7252

China - Xiamen
Tel: 86-592-2388138

China - Zhuhai
Tel: 86-756-3210040

ASIA/PACIFIC

India - Bangalore
Tel: 91-80-3090-4444

India - New Delhi
Tel: 91-11-4160-8631

India - Pune
Tel: 91-20-4121-0141

Japan - Osaka
Tel: 81-6-6152-7160

Japan - Tokyo
Tel: 81-3-6880-3770

Korea - Daegu
Tel: 82-53-744-4301

Korea - Seoul
Tel: 82-2-554-7200

Malaysia - Kuala Lumpur
Tel: 60-3-7651-7906

Malaysia - Penang
Tel: 60-4-227-8870

Philippines - Manila
Tel: 63-2-634-9065

Singapore
Tel: 65-6334-8870

Taiwan - Hsin Chu
Tel: 886-3-577-8366

Taiwan - Kaohsiung
Tel: 886-7-213-7830

Taiwan - Taipei
Tel: 886-2-2508-8600

Thailand - Bangkok
Tel: 66-2-694-1351

Vietnam - Ho Chi Minh
Tel: 84-28-5448-2100

EUROPE

Austria - Wels
Tel: 43-7242-2244-39
Fax: 43-7242-2244-393

Denmark - Copenhagen
Tel: 45-4450-2828
Fax: 45-4485-2829

Finland - Espoo
Tel: 358-9-4520-820

France - Paris
Tel: 33-1-69-53-63-20
Fax: 33-1-69-30-90-79

Germany - Garching
Tel: 49-8931-9700

Germany - Haan
Tel: 49-2129-3766400

Germany - Heilbronn
Tel: 49-7131-67-3636

Germany - Karlsruhe
Tel: 49-721-625370

Germany - Munich
Tel: 49-89-627-144-0
Fax: 49-89-627-144-44

Germany - Rosenheim
Tel: 49-8031-354-560

Israel - Ra'anana
Tel: 972-9-744-7705

Italy - Milan
Tel: 39-0331-742611
Fax: 39-0331-466781

Italy - Padova
Tel: 39-049-7625286

Netherlands - Drunen
Tel: 31-416-690399
Fax: 31-416-690340

Norway - Trondheim
Tel: 47-7289-7561

Poland - Warsaw
Tel: 48-22-3325737

Romania - Bucharest
Tel: 40-21-407-87-50

Spain - Madrid
Tel: 34-91-708-08-90
Fax: 34-91-708-08-91

Sweden - Gothenberg
Tel: 46-31-704-60-40

Sweden - Stockholm
Tel: 46-8-5090-4654

UK - Wokingham
Tel: 44-118-921-5800
Fax: 44-118-921-5820