



Chipsmall Limited consists of a professional team with an average of over 10 year of expertise in the distribution of electronic components. Based in Hongkong, we have already established firm and mutual-benefit business relationships with customers from,Europe,America and south Asia,supplying obsolete and hard-to-find components to meet their specific needs.

With the principle of “Quality Parts,Customers Priority,Honest Operation,and Considerate Service”,our business mainly focus on the distribution of electronic components. Line cards we deal with include Microchip,ALPS,ROHM,Xilinx,Pulse,ON,Everlight and Freescale. Main products comprise IC,Modules,Potentiometer,IC Socket,Relay,Connector.Our parts cover such applications as commercial,industrial, and automotives areas.

We are looking forward to setting up business relationship with you and hope to provide you with the best service and solution. Let us make a better world for our industry!



Contact us

Tel: +86-755-8981 8866 Fax: +86-755-8427 6832

Email & Skype: info@chipsmall.com Web: www.chipsmall.com

Address: A1208, Overseas Decoration Building, #122 Zhenhua RD., Futian, Shenzhen, China



Features

- GaN on SiC D-Mode Transistor Technology
- Unmatched, Ideal for Pulsed / CW Applications
- 50 V Typical Bias, Class AB
- Common-Source Configuration
- Thermally-Enhanced 3 x 6 mm 14-Lead DFN
- MTTF = 600 years ($T_J < 200^\circ\text{C}$)
- Halogen-Free “Green” Mold Compound
- RoHS* Compliant and 260°C Reflow Compatible
- MSL-1

Description

The MAGX-000035-01000P is a GaN on SiC unmatched power device offering the widest RF frequency capability, most reliable high voltage operation, lowest overall power transistor size, cost and weight in a “TRUE SMT” plastic-packaging technology.

Use of an internal stress buffer technology allows reliable operation at junction temperatures up to 200°C. The small package size and excellent RF performance make it an ideal replacement for costly flanged or metal-backed module components.

Ordering Information¹

Part Number	Package
MAGX-000035-01000P	Bulk Packaging
MAGX-000035-0100TP	500 Piece Reel
MAGX-L20035-01000P	900 - 1400 MHz Sample Board
MAGX-000035-PB4PPR	Custom Sample Board ²

1. Reference Application Note M513 for reel size information.
2. When ordering this sample evaluation board, choose a standard frequency range indicated on page 4/5 or specify a desired custom range. Custom requests may increase lead times.

* Restrictions on Hazardous Substances, European Union Directive 2002/95/EC.

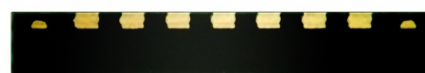

Functional Schematic

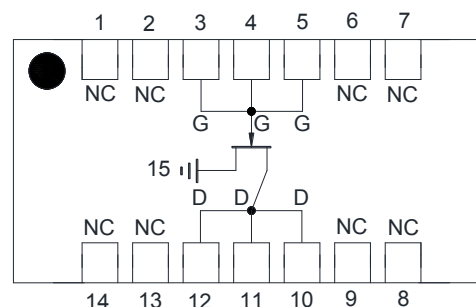

Pin Configuration³

Pin No.	Function	Pin No.	Function
1	No Connection	8	No Connection
2	No Connection	9	No Connection
3	V_{GG}/RF_{IN}	10	V_{DD}/RF_{OUT}
4	V_{GG}/RF_{IN}	11	V_{DD}/RF_{OUT}
5	V_{GG}/RF_{IN}	12	V_{DD}/RF_{OUT}
6	No Connection	13	No Connection
7	No Connection	14	No Connection
		15	Paddle ⁴

3. MACOM recommends connecting unused package pins to ground.
4. The exposed pad centered on the package bottom must be connected to RF and DC ground.

GaN Wideband 10 W CW / Pulsed Transistor in Plastic Package DC - 3.5 GHz

Rev. V3

Typical Performance: $V_{DD} = 50\text{ V}$, $I_{DQ} = 30\text{ mA}$, $T_A = 25^\circ\text{C}$

Parameter	30 MHz	1 GHz	2.5 GHz	3.5 GHz	Units
Gain	17	15	14	14	dB
Saturated Power (P_{SAT})	13	11	10	10	W
Power Gain at P_{SAT}	15	14	13	12	dB
PAE @ P_{SAT}	65	55	53	50	%

Electrical Specifications⁵: Freq. = 1.6 GHz, $T_A = 25^\circ\text{C}$, $Z_0 = 50\ \Omega$

Parameter	Symbol	Min.	Typ.	Max.	Units
CW RF FUNCTIONAL TESTS: $V_{DD} = 50\text{ V}$, $I_{DQ} = 30\text{ mA}$, P2.5 dB					
CW Output Power	P_{OUT}	-	10	-	W
Pulsed RF FUNCTIONAL TESTS: $V_{DD} = 50\text{ V}$, $I_{DQ} = 30\text{ mA}$, P2.5 dB, Pulse Width = 1 ms, Duty Cycle = 10%					
Pulsed Output Power	P_{OUT}	9.2	10.6	-	W
Pulsed Power Gain	G_P	14.2	14.8	-	dB
Pulsed Drain Efficiency	η_D	52	56	-	%
Load Mismatch Stability	VSWR-S	-	5:1	-	-
Load Mismatch Tolerance	VSWR-T	-	10:1	-	-

5. Electrical specifications measured in MACOM RF evaluation boards. See recommended tuning solutions on page 4.

Electrical Characteristics: $T_A = 25^\circ\text{C}$

Parameter	Test Conditions	Symbol	Min.	Typ.	Max.	Units
DC CHARACTERISTICS						
Drain-Source Leakage Current	$V_{GS} = -8\text{ V}$, $V_{DS} = 175\text{ V}$	I_{DS}	-	-	1.0	mA
Gate Threshold Voltage	$V_{DS} = 5\text{ V}$, $I_D = 2\text{ mA}$	$V_{GS(th)}$	-5	-3	-2	V
Forward Transconductance	$V_{DS} = 5\text{ V}$, $I_D = 250\text{ mA}$	G_M	0.20	-	-	S
DYNAMIC CHARACTERISTICS						
Input Capacitance	$V_{DS} = 0\text{ V}$, $V_{GS} = -8\text{ V}$, $F = 1\text{ MHz}$	C_{ISS}	-	2.2	-	pF
Output Capacitance	$V_{DS} = 50\text{ V}$, $V_{GS} = -8\text{ V}$, $F = 1\text{ MHz}$	C_{OSS}	-	0.9	-	pF
Reverse Transfer Capacitance	$V_{DS} = 50\text{ V}$, $V_{GS} = -8\text{ V}$, $F = 1\text{ MHz}$	C_{RSS}	-	0.1	-	pF

Absolute Maximum Ratings ^{6,7,8,9,10}

Parameter	Absolute Max.
Input Power	$P_{OUT} - G_P + 2.5 \text{ dBm}$
Drain Supply Voltage, V_{DD}	+65 V
Gate Supply Voltage, V_{GG}	-8 V to 0 V
Supply Current, I_{DD}	500 mA
Power Dissipation, CW @ 85°C	12 W
Power Dissipation (P_{AVG}), Pulsed @ 85°C	12 W
Junction Temperature ¹¹	200°C
Operating Temperature	-40°C to +95°C
Storage Temperature	-65°C to +150°C
ESD Maximum - Human Body Model (HBM)	400 V
ESD Maximum - Charged Device Model (CDM)	150 V

6. Exceeding any one or combination of these limits may cause permanent damage to this device.
7. MACOM does not recommend sustained operation near these survivability limits.
8. For saturated performance it is recommended that the sum of $(3 * V_{DD} + \text{abs}(V_{GG})) \leq 175 \text{ V}$.
9. CW operation at V_{DD} voltages above 50 V is not recommended.
10. Operating at nominal conditions with $T_J \leq 200^\circ\text{C}$ will ensure $\text{MTTF} > 1 \times 10^6$ hours. Junction temperature directly affects device MTTF and should be kept as low as possible to maximize lifetime.
11. Junction Temperature (T_J) = $T_C + \Theta_{JC} * ((V * I) - (P_{OUT} - P_{IN}))$

Typical CW thermal resistance (Θ_{JC}) = 5.8°C/W

- a) For $T_C = 83^\circ\text{C}$,
 $T_J = 124^\circ\text{C}$ @ 50 V, 330 mA, $P_{OUT} = 10\text{W}$, $P_{IN} = 0.6\text{W}$

Typical transient thermal resistances:

- b) 300 μs pulse, 10% duty cycle, $\Theta_{JC} = 1.94^\circ\text{C/W}$
 For $T_C = 83^\circ\text{C}$,
 $T_J = 97^\circ\text{C}$ @ 50 V, 325mA, $P_{OUT} = 9.8\text{W}$, $P_{IN} = 0.6 \text{ W}$

- c) 1 ms pulse, 10% duty cycle, $\Theta_{JC} = 2.01^\circ\text{C/W}$
 For $T_C = 83^\circ\text{C}$,
 $T_J = 98^\circ\text{C}$ @ 50 V, 325mA, $P_{OUT} = 9.8\text{W}$, $P_{IN} = 0.6\text{W}$

- d) 1 ms pulse, 20% duty cycle, $\Theta_{JC} = 2.56^\circ\text{C/W}$
 For $T_C = 83^\circ\text{C}$,
 $T_J = 101^\circ\text{C}$ @ 50 V, 325 mA, $P_{OUT} = 9.8 \text{ W}$, $P_{IN} = 0.6 \text{ W}$

Evaluation Board Details and Recommended Tuning Solutions

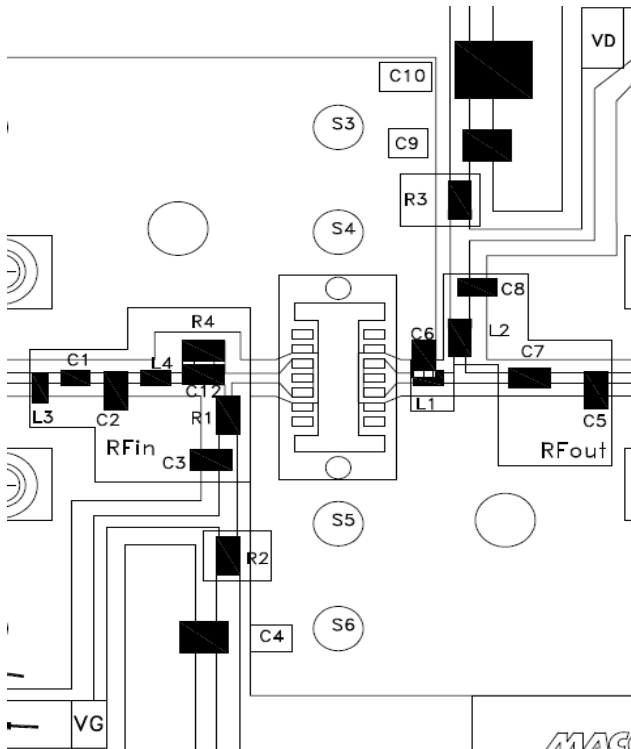

Parts measured on evaluation board (8-mil thick RO4003C). Electrical and thermal ground is provided using copper-filled via hole array (not pictured), and evaluation board is mounted to a metal plate.

Matching is provided using lumped elements as shown at left. Recommended tuning solutions for 3 frequency ranges are detailed in the parts list below.

Bias Sequencing

Turning the device ON

1. Set V_G to the pinch-off (V_P), typically -5 V.
2. Turn on V_D to nominal voltage (50 V).
3. Increase V_{GS} until the I_{DS} current is reached.
4. Apply RF power to desired level.

Turning the device OFF

1. Turn the RF power off.
2. Decrease V_G down to V_P .
3. Decrease V_D down to 0 V.
4. Turn off V_G .

Parts List (N/A = not applicable for this tuning solution)

Part	Frequency = 900-1400 MHz	Frequency = 1600 MHz	Frequency = 1625-1675 MHz
C1	0402, 6.8 pF, $\pm 5\%$, 200V ATC	0402, 4.7 pF, $\pm 0.1\text{pF}$, 200 V, ATC	0402, 3.3 pF, $\pm 0.1\text{pF}$, 200 V, ATC
C2	0603, 6.8 pF, $\pm 0.1\text{pF}$, 250 V, ATC	0603, 8.2 pF, $\pm 0.1\text{pF}$, 250 V, ATC	0603, 8.2 pF, $\pm 0.1\text{pF}$, 250 V, ATC
C3	0603, 82 pF, $\pm 10\%$, 250 V, ATC	0603, 68 pF, $\pm 10\%$, 250 V, ATC	0603, 68 pF, $\pm 10\%$, 250 V, ATC
C4	0805, 1000 pF, 100 V, 5%, AVX	0805, 1000 pF, 100 V, 5%, AVX	0805, 1000 pF, 100 V, 5%, AVX
C5	N/A	0603, 1.5 pF, $\pm 0.1\text{pF}$, 250 V, ATC	N/A
C6	N/A	N/A	0603, 1.5 pF, $\pm 0.1\text{pF}$, 250 V, ATC
C7	0603, 39 pF, $\pm 10\%$, 250 V, ATC	0603, 20 pF, $\pm 10\%$ pF, 250 V, ATC	0603, 20 pF, $\pm 10\%$ pF, 250 V, ATC
C8	0603, 82 pF, $\pm 10\%$, 250 V, ATC	0603, 68 pF, $\pm 10\%$, 250 V, ATC	0603, 68 pF, $\pm 10\%$, 250 V, ATC
C9	0805, 1000 pF, 100 V, 5%, AVX	0805, 1000 pF, 100 V, 5%, AVX	0805, 1000 pF, 100 V, 5%, AVX
C10	0805, 1000 pF, 100 V, 5%, AVX	0805, 1000 pF, 100 V, 5%, AVX	0805, 1000 pF, 100 V, 5%, AVX
C11	N/A	N/A	N/A
C12	N/A	0603, 10 pF, $\pm 0.1\text{pF}$, 250 V, ATC	0603, 6.8 pF, $\pm 0.1\text{pF}$, 250 V, ATC
R1	240 Ω , 0603, 5%	200 Ω , 0603, 5%	200 Ω , 0603, 5%
R2	1.0 Ω , 0603, 5%	1.0 Ω , 0603, 5%	1.0 Ω , 0603, 5%
R3	1.0 Ω , 0603, 5%	1.0 Ω , 0603, 5%	1.0 Ω , 0603, 5%
R4	8.2 Ω , 0603, 5%	33 Ω , 0603, 5%	75 Ω , 0603, 5%
L1	0402HP, 3.3 nH, 5%, Coilcraft	0402HP, 2.7 nH, 5%, Coilcraft	Shorting tab
L2	0603HP, 6.8 nH, 5%, Coilcraft	0603HP, 1.6 nH, 5%, Coilcraft	0603HP, 1.6 nH, 5%, Coilcraft
L3	0402CS, 4.3 nH, 5%, Coilcraft	0402HP, 2.7 nH, 5%, Coilcraft	0402HP, 2.7 nH, 5%, Coilcraft
L4	0402CS, 3.3nH 5% (900-1300MHz); or 2.4nH, 5% for 1000MHz-1400MHz, Coilcraft	0402HP, 2.7 nH, 5%, Coilcraft	0402HP, 2.7 nH, 5%, Coilcraft

Evaluation Board Details and Recommended Tuning Solutions— 2700-3600 MHz

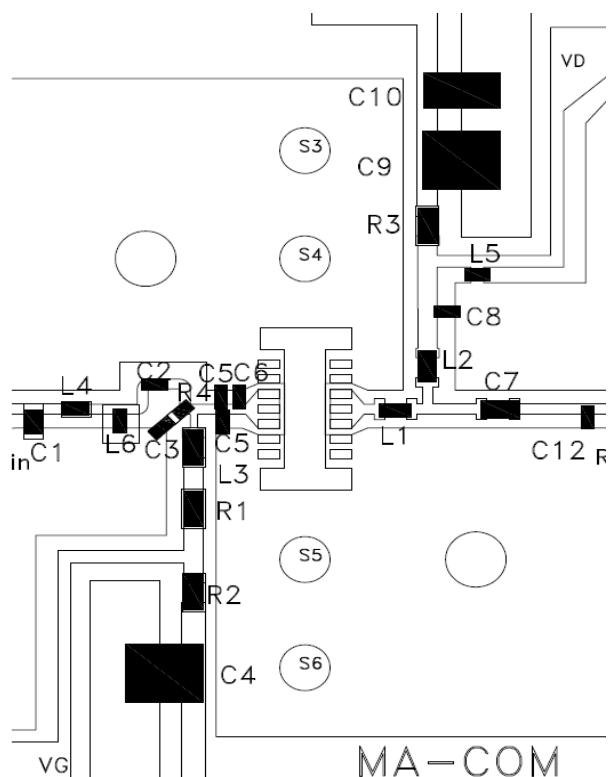

Parts measured on evaluation board (8-mil thick RO4003C). Electrical and thermal ground is provided using copper-filled via hole array (not pictured), and evaluation board is mounted to a metal plate.

Matching is provided using lumped elements as shown at left. Recommended tuning solutions for 3 frequency ranges are detailed in the parts list below.

Bias Sequencing

Turning the device ON

1. Set V_G to the pinch-off (V_P), typically -5 V.
2. Turn on V_D to nominal voltage (50 V).
3. Increase V_{GS} until the I_{DS} current is reached.
4. Apply RF power to desired level.

Turning the device OFF

1. Turn the RF power off.
2. Decrease V_G down to V_P .
3. Decrease V_D down to 0 V.
4. Turn off V_G .

Parts List

Part	Frequency = 2700 - 3600 MHz
C1, C12	0402 0.7 pF, ± 0.05 pF, 200 V, ATC
C2	0402, 1.3 pF, ± 0.05 pF, 200 V, ATC
C3	0402, 2.7 pF, ± 0.1 pF, 200 V, ATC
C4, C9	0805, 1000 pF, 100 V, 5%, AVX
C5	0402, 2.2 pF, ± 0.1 pF, 200 V, ATC
C6	0402, 2.0 pF, ± 0.1 pF, 200 V, ATC
C7	0603, 10 pF, $\pm 5\%$, 200 V, ATC
C8	0402 10 pF, $\pm 5\%$, 200 V, ATC
C10	1210, 1uF, 100 V, 20%, ATC
R1	200 Ohm, 0603, 5%
R2	Shorting tab
R3	1 Ohm, 0603, 5%
L1	Shorting tab
L2	Shorting tab
L3	0603CS, 10nH, 5%, Coilcraft
L4, L6	0402HP, 1.0nH, 5%, Coilcraft
L5	0402HP, 12nH, 5%, Coilcraft

Lead-Free 3x6 mm 14-Lead DFN[†]

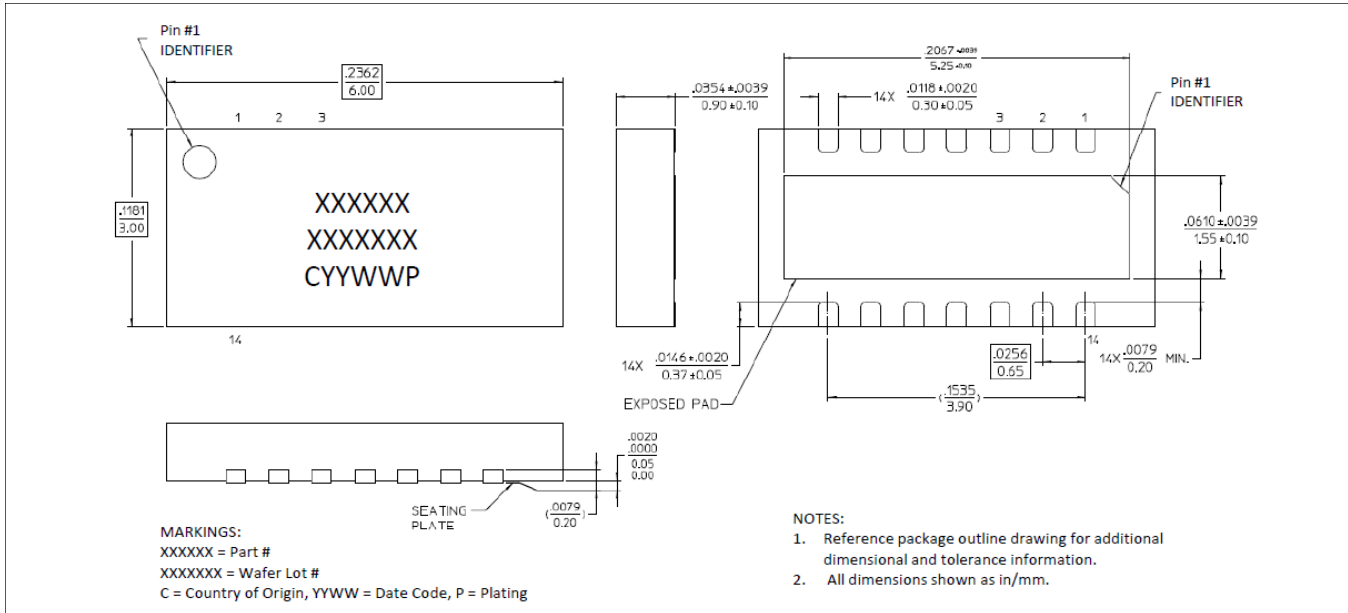

[†] Reference Application Note S2083 for lead-free solder reflow recommendations. Meets JEDEC moisture sensitivity level 1 requirements. Plating is Ni/Pd/Au.

Handling Procedures

Please observe the following precautions to avoid damage:

Static Sensitivity

Gallium Nitride Devices and Circuits are sensitive to electrostatic discharge (ESD) and can be damaged by static electricity. Proper ESD control techniques should be used when handling these Class 1A devices.

Applications Section

Thermal Performance: Freq. = 1200 MHz, $T_C = 85^\circ\text{C}$, $V_{DD} = +50\text{ V}$, $I_{DQ} = 30\text{ mA}$, $Z_0 = 50\ \Omega$

Power (Output & Dissipated) and Transient Junction Temperature vs. Pulse Duration and Duty Cycle

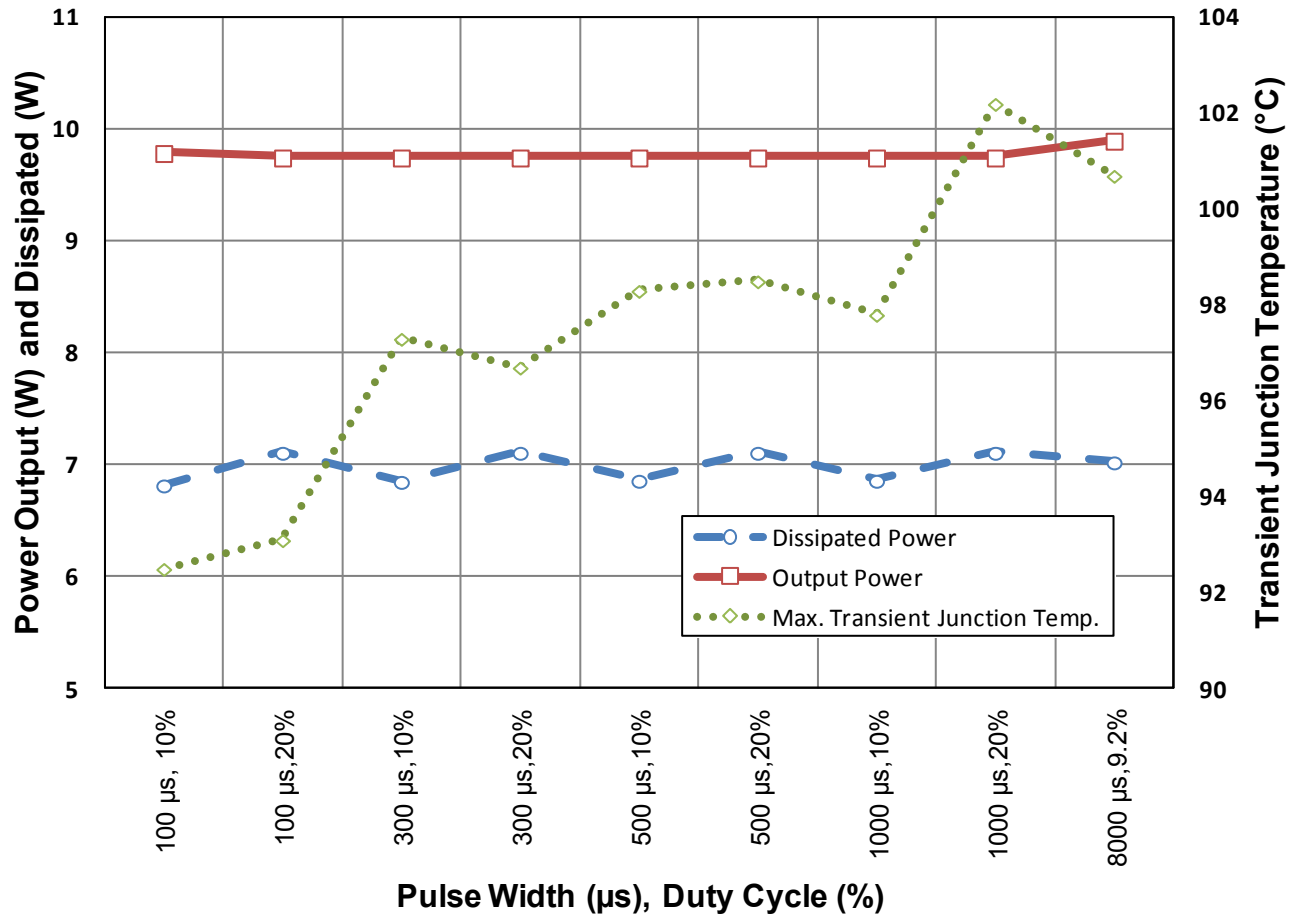

Pulse Width, Duty Cycle	100 µs, 10%	100 µs, 20%	300 µs, 10%	300 µs, 20%	500 µs, 10%	500 µs, 20%	1000 µs, 10%	1000 µs, 20%	8000 µs, 9.2%
Power Dissipation (W)	6.8	7.1	6.9	7.1	6.9	7.1	6.9	7.1	7.0
1.2 GHz P_{OUT} (W)	9.79	9.75	9.75	9.75	9.75	9.75	9.75	9.75	9.90
Max. Transient Junction Temp. ($^\circ\text{C}$)	92.5	93.1	97.3	96.7	98.3	98.5	97.8	102.2	100.7

Junction temperature measured using High-Speed Transient (HST) temperature detection microscopy.

Applications Section

Typical Pulsed Performance Curves (reference 900 MHz - 1400 MHz parts list, L4 = 2.4 nH):
900 - 1400 MHz, 200 μ s Pulse, 20% Duty Cycle, P_{IN} = 0.5 W, V_{DD} = +50 V, T_A = 25°C, Z₀ = 50 Ω

Output Power vs. Frequency

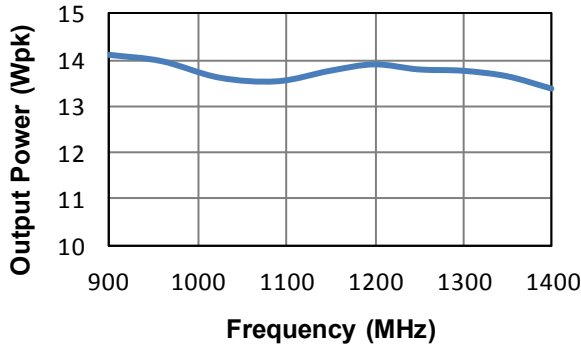

Drain Efficiency vs. Frequency

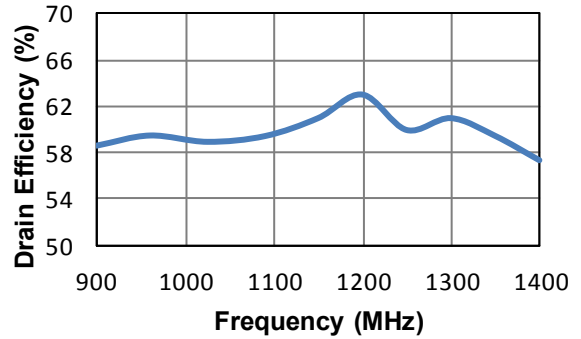

Power Gain vs. Frequency

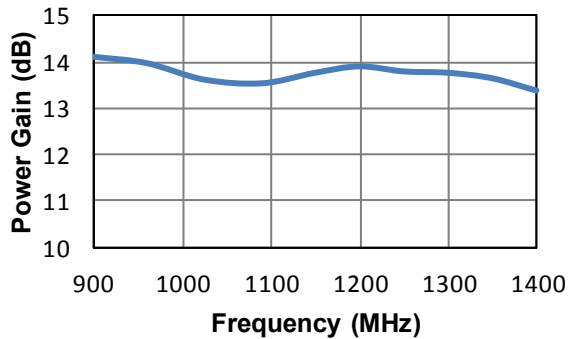

Input Return Loss vs. Frequency

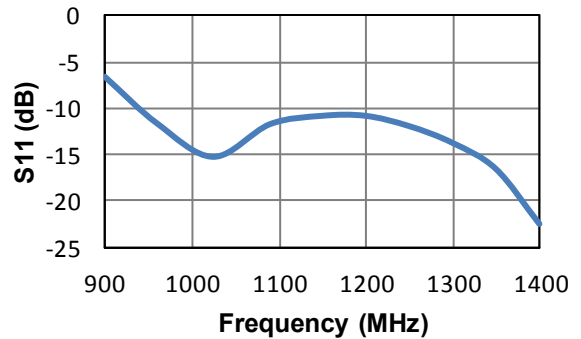

Pulse Droop vs. Frequency

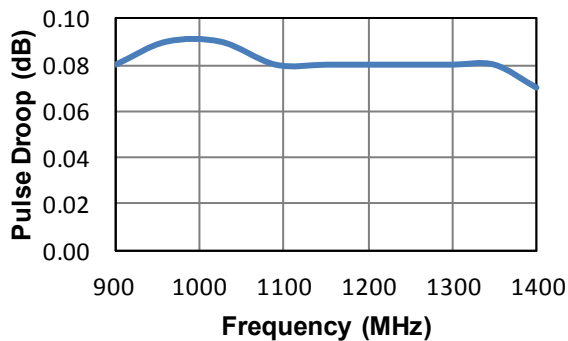

Output Drive & Power Gain vs. Input Power

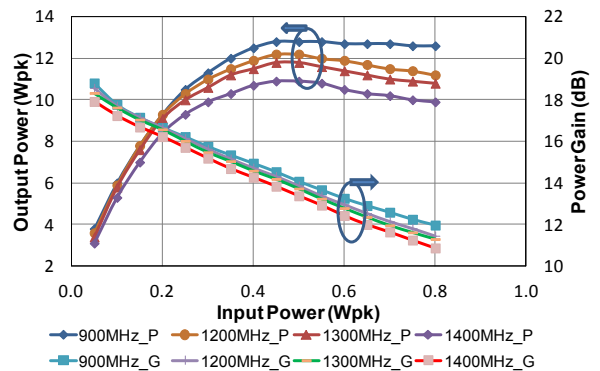

Applications Section

Typical CW Performance Curves (reference 1625MHz-1675MHz parts list):
1650 MHz, $V_{DD} = +50\text{ V}/+28\text{ V}$, $I_{DQ} = 30\text{ mA}$, CW, $T_A = 25^\circ\text{C}$, $Z_0 = 50\ \Omega$

Output Power vs. Input Power

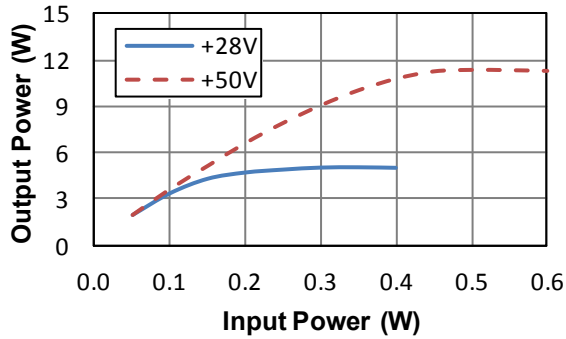

Drain Efficiency vs. Input Power

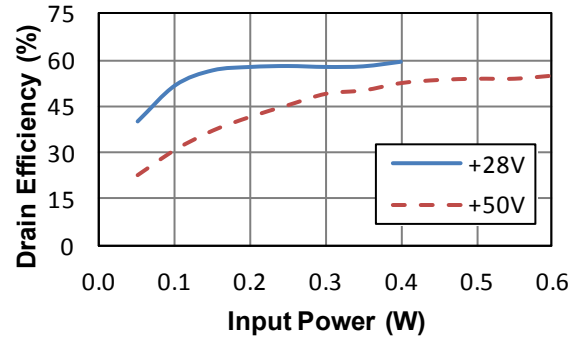

Power Gain vs. Input Power

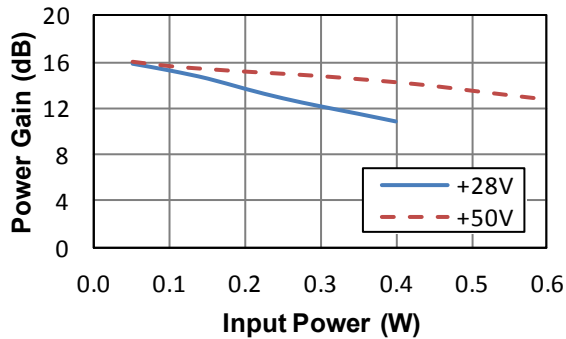

Input Return Loss vs. Frequency

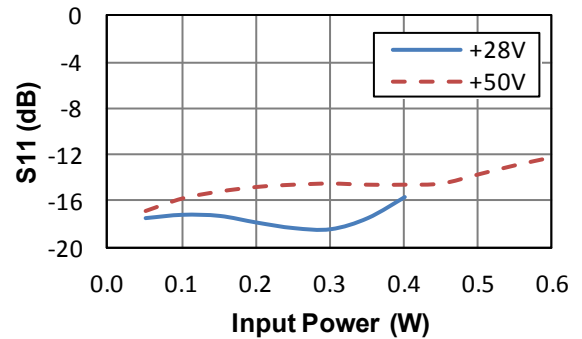

Applications Section

Typical S-Band Performance Curves (reference 2.7 - 3.6 GHz parts list):

2.7 - 3.6 GHz, 200 μ s Pulse, 20% Duty Cycle, $P_{IN} = 0.8$ W, $V_{DD} = +50$ V/+45 V, $T_A = 25^\circ\text{C}$, $Z_0 = 50 \Omega$

Output Power vs. Frequency

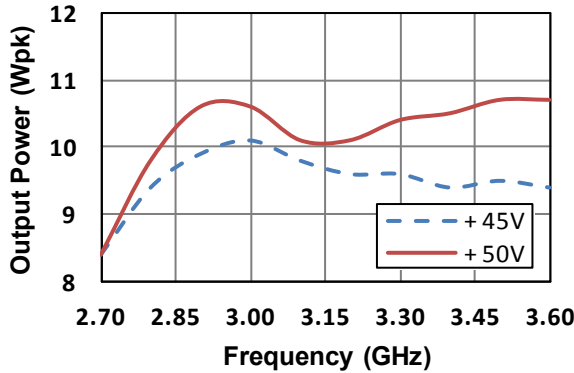

Drain Efficiency vs. Frequency

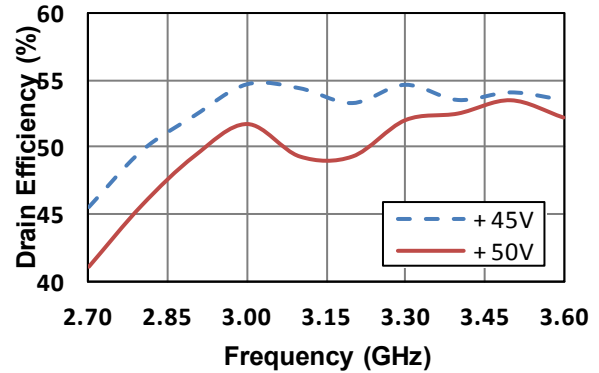

Power Gain vs. Frequency

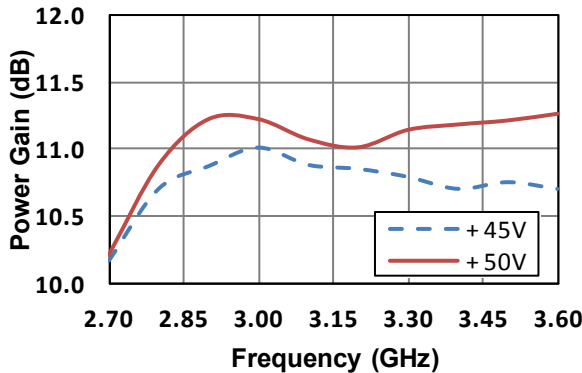

Input Return Loss vs. Frequency

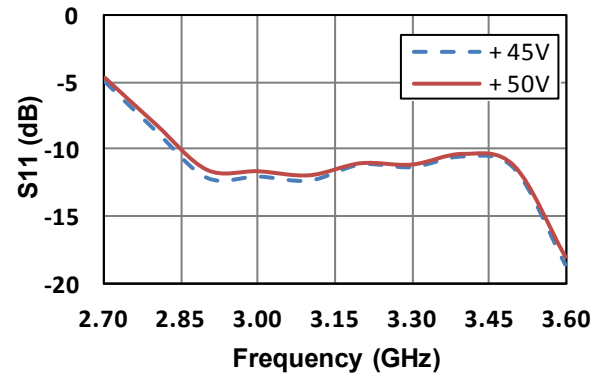

Pulse Droop vs. Frequency

