



Chipsmall Limited consists of a professional team with an average of over 10 year of expertise in the distribution of electronic components. Based in Hongkong, we have already established firm and mutual-benefit business relationships with customers from,Europe,America and south Asia,supplying obsolete and hard-to-find components to meet their specific needs.

With the principle of “Quality Parts,Customers Priority,Honest Operation,and Considerate Service”,our business mainly focus on the distribution of electronic components. Line cards we deal with include Microchip,ALPS,ROHM,Xilinx,Pulse,ON,Everlight and Freescale. Main products comprise IC,Modules,Potentiometer,IC Socket,Relay,Connector.Our parts cover such applications as commercial,industrial, and automotives areas.

We are looking forward to setting up business relationship with you and hope to provide you with the best service and solution. Let us make a better world for our industry!



Contact us

Tel: +86-755-8981 8866 Fax: +86-755-8427 6832

Email & Skype: info@chipsmall.com Web: www.chipsmall.com

Address: A1208, Overseas Decoration Building, #122 Zhenhua RD., Futian, Shenzhen, China



MAXIM

MAX105 Evaluation Kit

Evaluates: MAX105/MAX107

General Description

The MAX105 evaluation kit (EV kit) is a fully assembled and tested circuit board that contains all the components necessary to evaluate the performance of the MAX105, dual channel, 6-bit (800MSPS), or the MAX107, dual channel, 6-bit (400MSPS) high-speed analog-to-digital converter (ADC). The MAX105 ADC is able to process differential or single-ended analog inputs. The EV kit allows the user to evaluate the ADC with either type of signals. The digital output produced by the ADC can be easily sampled with a user-provided high-speed logic analyzer or data-acquisition system. The EV kit comes with the MAX105 installed. To evaluate the MAX107, replace the MAX105 with the MAX107.

Component List

DESIGNATION	QTY	DESCRIPTION
C1, C5, C9, C13, C16, C18, C20, C22	8	47pF $\pm 10\%$, +50V COG ceramic capacitors (0402) Murata GRM36COG470K050AD
C2, C6, C10, C14, C15, C17, C19, C21, C24-C28, C30	14	0.01 μ F $\pm 10\%$, +16V X7R ceramic capacitors (0402) Murata GRM36X7R103K016AD
C3, C4, C7, C8, C11, C12	6	100pF $\pm 5\%$, +50V COG ceramic capacitors (0402) Murata GRM36COG101J050AD
C23, C29	2	10 μ F $\pm 10\%$, +25V tantalum capacitors (CASE D) AVX TAJD106K025R
L1-L4	4	Ferrite beads 600 Ω at 100MHz, 500mA, 0.3 Ω DCR Murata BLM21A601R
R1-R6	6	51.1 Ω $\pm 1\%$ resistors (0402)
R7-R32	26	100 Ω $\pm 1\%$ resistors (0402)
J1-J6	6	SMA connectors (edge-mounted)
JU1, JU2	0	Not installed 2-pin headers
JU4-JU55	52	2-pin headers
JU3	0	Not installed 3-pin header
AVCC, AGND, OVCC, OGND	4	Test point hooks
U1	1	MAX105ECS (80-pin TQFP-EP)
None	1	MAX105 PC board
None	1	MAX105 data sheet
None	1	MAX105 EV kit data sheet

Features

- ◆ Two Matched 6-Bit, 800 MspS ADCs
- ◆ 0.8V_{p-p} Input Signal Range
- ◆ Demultiplexed Differential LVDS Outputs
- ◆ Square-Pin Headers for Easy Connection of Logic Analyzer to Digital Outputs
- ◆ Four-layer PC Board with Separate Analog and Digital Power and Ground Connections
- ◆ Fully Assembled and Tested with MAX105 Installed

Ordering Information

PART	TEMP. RANGE	IC PACKAGE
MAX105EVKIT	0°C to 70°C	80 TQFP-EP*

*Exposed pad

ADC Selection Table

PART	SPEED (MSPS)
MAX105ECS	800
MAX107ECS	400

Component Suppliers

SUPPLIER	PHONE	FAX
AVX	803-946-0690	803-626-3123
Murata	814-237-1431	814-238-0490

Note: Please indicate that you are using the MAX105 when contacting these component suppliers.

MAX105 Evaluation Kit

Quick Start

Test Equipment Required

- DC power supplies:
Digital +3.3V, 510mA
Analog +5.0V, 350mA
- Generator with low phase-noise for clock input (e.g., HP8662A, HP8663A, or equivalent)
- Two signal generators for analog signal inputs (e.g., HP8662A, HP8663A, or equivalent)
- Logic analyzer or data-acquisition system (e.g., HP16500C series, HP16517A 1.25Gbps state module for single-ended evaluation).
- User-selected analog bandpass filters (e.g., TTE Elliptical Bandpass Filter, or equivalent)
- Digital Voltmeter
- Baluns (e.g., MA/COM H-9-SMA)
- 50Ω terminators with SMA connectors

The MAX105 EV kit is a fully assembled and tested surface-mount board. Follow the steps below for board operation. **Do not turn on power supplies or enable function generators until all connections are completed.**

- 1) Connect a signal generator with low phase-jitter to the clock inputs CLK- and CLK+ through a balun (Figure 1). For a single-ended clock input (Figure 2), connect a 500mV (354mV_{RMS}, +4dBm) amplitude from the signal generator to the CLK+ input and terminate the unused CLK- input with a 50Ω termination resistor to AGND.
- 2) For differential operation, connect a ±380mV 270mV_{RMS} (approximately -0.5dB FS) sine-wave test signal to connector A of the balun. Terminate connector B of the balun with a 50Ω terminator. Attach connector C of the balun to the analog input VINI+ (VINQ+). Attach connector D of the balun to the analog input VINI- (Figure 1). For single-ended operation, apply the test signal to either VINI+ (VINQ+) or VINI- (VINQ-) and terminate the unused input with a 50Ω resistor to AGND (Figure 2). For best results, use a narrow bandpass filter designed for the frequency of interest to reduce the harmonic distortion of the signal generator.
- 3) Phase-lock both the VINI and/or VINQ signal generators with the clock generator.
- 4) Connect a logic analyzer, such as the HP16500 with the HP16517 plug-in module to monitor the I or Q channel of the MAX105. Note that the podlets are single-ended to ground and you may need to

remove the 100Ω termination resistors R7–R32 to increase the logic signal swing. Reflections are absorbed by the back-terminated LVDS drivers.

Note: Two state modules are required to monitor both I and Q channel simultaneously.

- 5) Connect the logic analyzer clock to the DREADY+ output on the EV kit and set the logic analyzer to trigger on the falling edge of the DREADY+ signal.
- 6) Connect a +5V power supply to the pad marked AVCC. Connect the supply's ground to the pad marked AGND.
Note: MAX105 has separate AVCC_I and AVCC_Q supply pins.
- 7) Connect a +3.3V power supply to the pad marked OVCC. Connect the supply's ground to the pad marked OGND. Tie AGND and OGND together at the power supplies.
Note: MAX105 has separate OVCC_I and OVCC_Q supply pins.
- 8) Turn on both power supplies, then the signal sources. Capture the digitized outputs from the MAX105 with the logic analyzer and transfer the digital record to a PC for data analysis.

Detailed Description

The MAX105 EV kit evaluates the performance of the MAX105 dual channel, 6-bit ADC at a maximum clock frequency of 800MHz (400MHz for MAX107). The MAX105 ADC can process differential or single-ended analog and clock inputs. The user may apply baluns to generate differential signals from a single-ended analog signal to the EV kit.

The EV kit's PC board incorporates a four-layer board design to optimize the performance of the MAX105 in a 50Ω environment. Separate analog and digital ground planes minimize noise coupling between analog and digital signals. The EV kit requires a +5.0V power supply applied to the analog power plane, and a +3.3V power supply applied to the digital power plane. Access to the outputs is provided through the two-pin headers (Table 1) all around the edge of the board. A silkscreen on the PC board's top layer indicates reference designations.

MAX105 Evaluation Kit

Evaluates: MAX105/MAX107

Table 1. LVDS Outputs and Functional Description

LVDS OUTPUT SIGNALS	EV KIT HEADER LOCATION	FUNCTIONAL DESCRIPTION
P5I+, P5I- (MSB) P4I+, P4I- P3I+, P3I- P2I+, P2I- P1I+, P1I- P0I+, P0I- (LSB)	JU52, JU53 JU48, JU49 JU44, JU45 JU12, JU13 JU40, JU41 JU36, JU37	Primary in-phase differential outputs from MSB to LSB. "+" indicates the true value, "-" denotes the complementary outputs
A5I+, A5I- (MSB) A4I+, A4I- A3I+, A3I- A2I+, A2I- A1I+, A1I- A0I+, A0I- (LSB)	JU54, JU55 JU50, JU51 JU46, JU47 JU18, JU19 JU42, JU43 JU38, JU39	Auxiliary in-phase differential outputs from MSB to LSB. "+" indicates the true value, "-" denotes the complementary outputs
P5Q+, P5Q- (MSB) P4Q+, P4Q- P3Q+, P3Q- P2Q+, P2Q- P1Q+, P1Q- P0Q+, P0Q- (LSB)	JU6, JU7 JU10, JU11 JU16, JU17 JU22, JU23 JU27, JU26 JU31, JU30	Primary quadrature differential outputs from MSB to LSB. "+" indicates the true value, "-" denotes the complementary outputs
A5Q+, A5Q- (MSB) A4Q+, A4Q- A3Q+, A3Q- A2Q+, A2Q- A1Q+, A1Q- A0Q+, A0Q- (LSB)	JU4, JU5 JU8, JU9 JU14, JU15 JU20, JU21 JU25, JU24 JU29, JU28	Auxiliary quadrature differential outputs from MSB to LSB. "+" indicates the true value, "-" denotes the complementary outputs
DOR+, DOR-	JU33, JU32	Out-of-range signal's true and complementary outputs
DREADY+, DREADY-	JU34, JU35	Data Ready LVDS output latch clock. Output data changes on the rising edge of DREADY+

Power Supplies

The MAX105 EV kit requires separate analog and digital power supplies for best performance. A +3.3V \pm 10% power supply is used to power the digital portion (OVCC) of the ADC. A separate +5.0V \pm 5% power supply is used to power the analog portion (AVCC) of the ADC. Ferrite beads are used to filter out high-frequency noise at the analog power supply. At 100MHz, the ferrite beads have an impedance of 600 Ω .

Clock

The clock signals CLK \pm are AC-coupled from the SMA connectors J3 and J4. The DC-biasing level is internally set to the reference voltage. The MAX105's clock input resistance is 5k Ω . However, the EV kit's clock input resistance is set by an external resistor to 50 Ω . An AC-coupled, differential sine-wave signal may be applied to the CLK \pm SMA connectors (Figure 3). The signal must not exceed a magnitude of 1.4V_{RMS}. The typical clock frequency should be 800MHz for MAX105

(400MHz for MAX107).

I/Q Input Signals

The input signals are AC-coupled. The DC biasing level is internally set to the reference voltage V_{REF}. The MAX105's analog input resistance is 2k Ω per input. However, the EV kit's I/Q input resistance is set to 50 Ω by an external resistor. For single-ended operation, apply a signal to one of the analog inputs and terminate the opposite complimentary input with a 50 Ω resistor to ground.

Note: When a differential signal is applied to the ADC, the positive and negative input pins of the ADC each receive half of the input signal supplied to the balun. A common mode voltage of +2.5V is established within the part and blocked by the AC-coupling capacitors.

MAX105 Evaluation Kit

Reference

An on-chip reference is provided with a nominal +2.5V output. This voltage is then processed to drive the resistor ladder in the ADC core. A buffered reference voltage is also used as the DC-bias voltage for the analog input.

Demultiplexing and LVDS Outputs

Each ADC provides six differential outputs (two's complement code) at 800MHz, which fan out to 12 differential outputs at 400MHz after the on-chip demultiplexer. To interface with lower supply CMOS DSP chips, all outputs provide LVDS-compatible voltage levels. The LVDS outputs will have approximately $\pm 270\text{mV}$ swing differential with a common mode around 1.25V. The differential output impedance is roughly 100Ω . For details, refer to IEEE standard 1596.3.

***Note: To boost the output signal swing for single-ended data capture with the HP16500C and HP16517A high-speed state module, all 100Ω termination resistors (R7–R32) should be removed.**

Out-of-Range (DOR) Signal

The out-of-range signal (DOR+, DOR-) flags high when either the I or Q input is below -FS or above +FS. The out-of-range signal has the same latency as the ADC output data or is demultiplexed the same way. For an 800MHz system DOR+ and DOR- are clocked at 400MHz.

Data Ready (DREADY) Output

In single-ended data capture mode the clock interface of the logic analyzer should be connected to the DREADY output at headers JU34 or JU35 on the EV kit. Since both the primary and auxiliary outputs change on the rising edge of DREADY, set the logic analyzer to trigger on the falling edge. DREADY and the data outputs are internally time aligned, which places the falling edge of DREADY in the approximate center of the valid data window, resulting in the maximum setup and hold time for the logic analyzer.

Board Layout

The MAX105 EV kit is a four-layer PC board design (Figure 4), optimized for high-speed signals. The board is constructed from low-loss GETek core material which has a relative dielectric constant of 3.9 ($\epsilon_R = 3.9$). The GETek material used in the MAX105 EV kit board offers improved high frequency and thermal properties over standard FR4 board material. All high-speed signals are routed with differential microstrip transmission lines.

Table 2. MAX105 EV kit Layers

LAYER	DESCRIPTION
Layer I, Top Layer	Components, Headers, Connectors, Test Pads, AV _{CC} , OV _{CC} , AGND, OGND, Analog 50Ω microstrip lines. 100Ω Termination Resistors
Layer II, Ground Plane	AGND, AGNDI, AGNDQ, AGNDR, OGND, OGNDI, OGNDQ
Layer III, Power Plane	AV _{CC} , AV _{CC} I, AV _{CC} Q, AV _{CC} R, OV _{CC} , OV _{CC} I, OV _{CC} Q
Layer IV, Bottom Layer	AGND, Components

Special Layout Considerations

Special effort was made in the board layout to separate the analog and digital portions of the circuit. 50Ω microstrip transmission lines are used for analog and clock inputs, as well as for all digital LVDS outputs. The power plane is separated into strips to provide isolation between different sections of the circuit (e.g., AV_{CC}I and AV_{CC}Q or OV_{CC}I and OV_{CC}Q). All differential outputs are properly terminated with 100Ω termination resistors between true and complementary digital outputs.

The PC board comes in a circular shape to ensure the best possible trace length matching for the 50Ω microstrip lines. The electrical lengths of the 50Ω microstrip lines are matched to within a few picoseconds to minimize layout-dependent delays. The propagation delay on the MAX105 EV kit board is about 130ps/inch.

The line width for a differential microstrip is 2.5mils with a ground plane height of 14mils which is a standard GETek core thickness. Table 2 shows PC board layers of the EV kit.

MAX105 Evaluation Kit

Evaluates: MAX105/MAX107

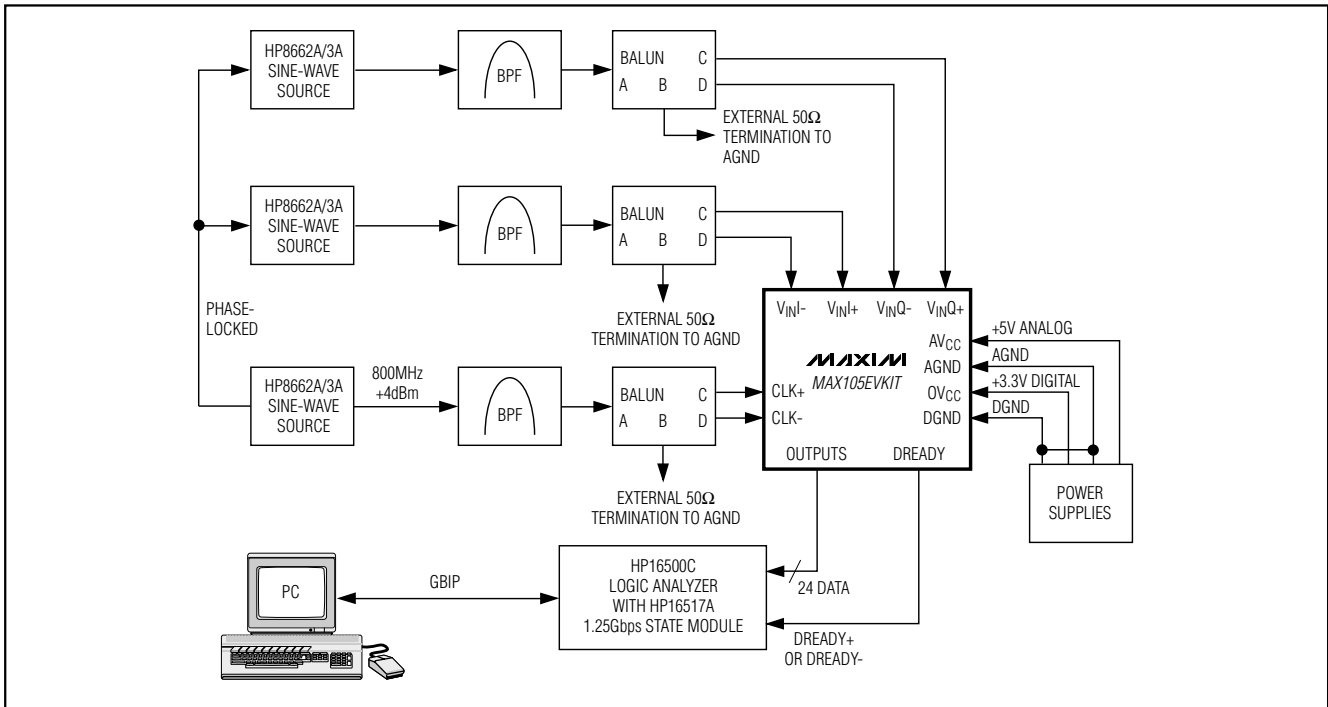

Figure 1. Typical Evaluation Setup with Differential Analog Inputs, Differential Clock Drive, and Single-Ended Data Capture

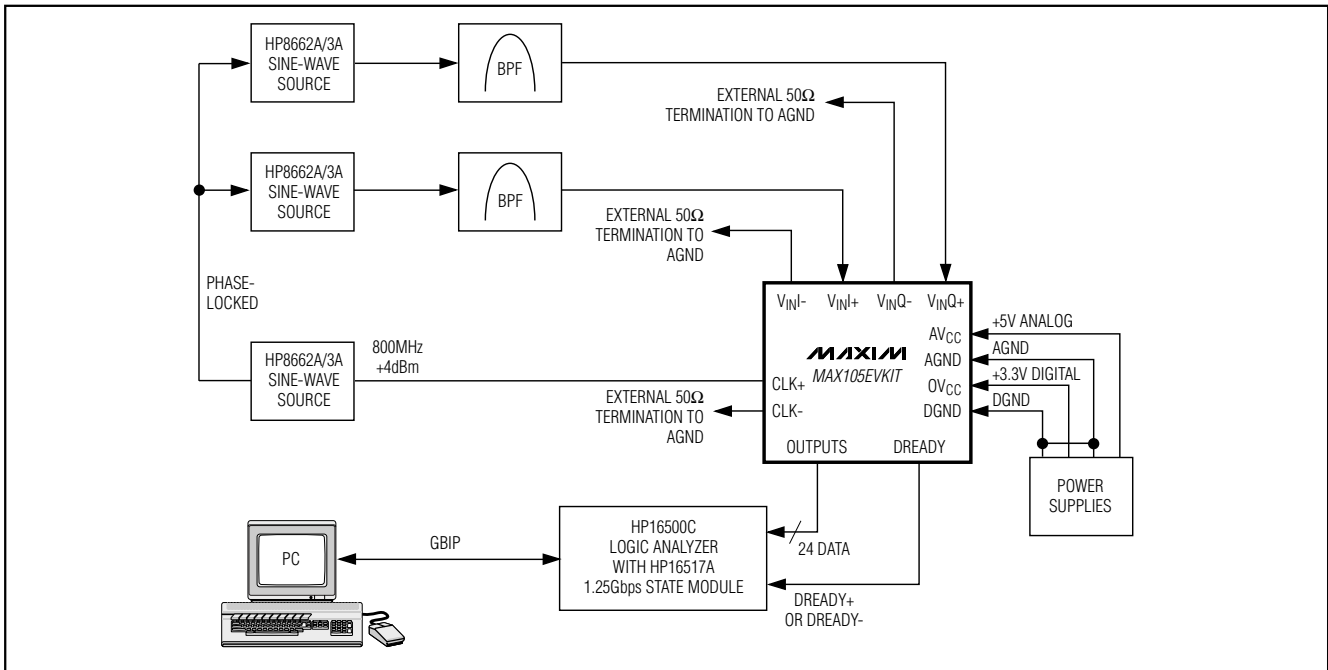

Figure 2. Typical Evaluation Setup with Single-Ended Analog Inputs, Single-Ended Clock Drive, and Single-Ended Data Capture

MAX105 Evaluation Kit

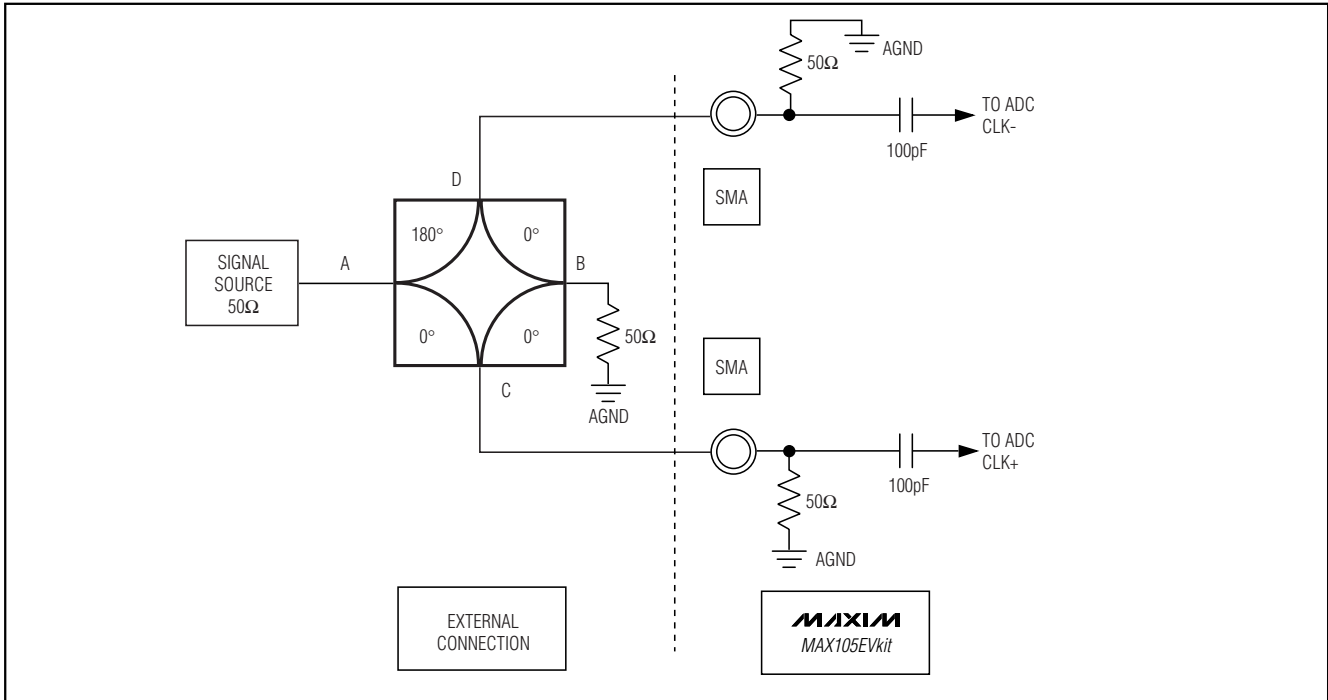

Figure 3. AC-Coupled, Differential Clock Drive

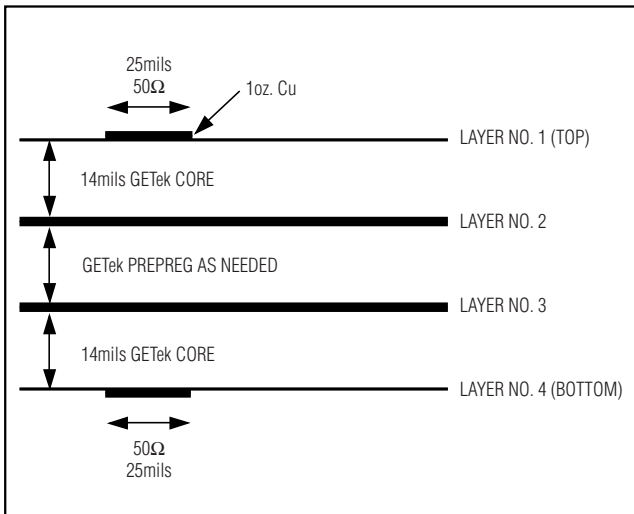

Figure 4. PC Board Stacking

MAX105 Evaluation Kit

Evaluates: MAX105/MAX107

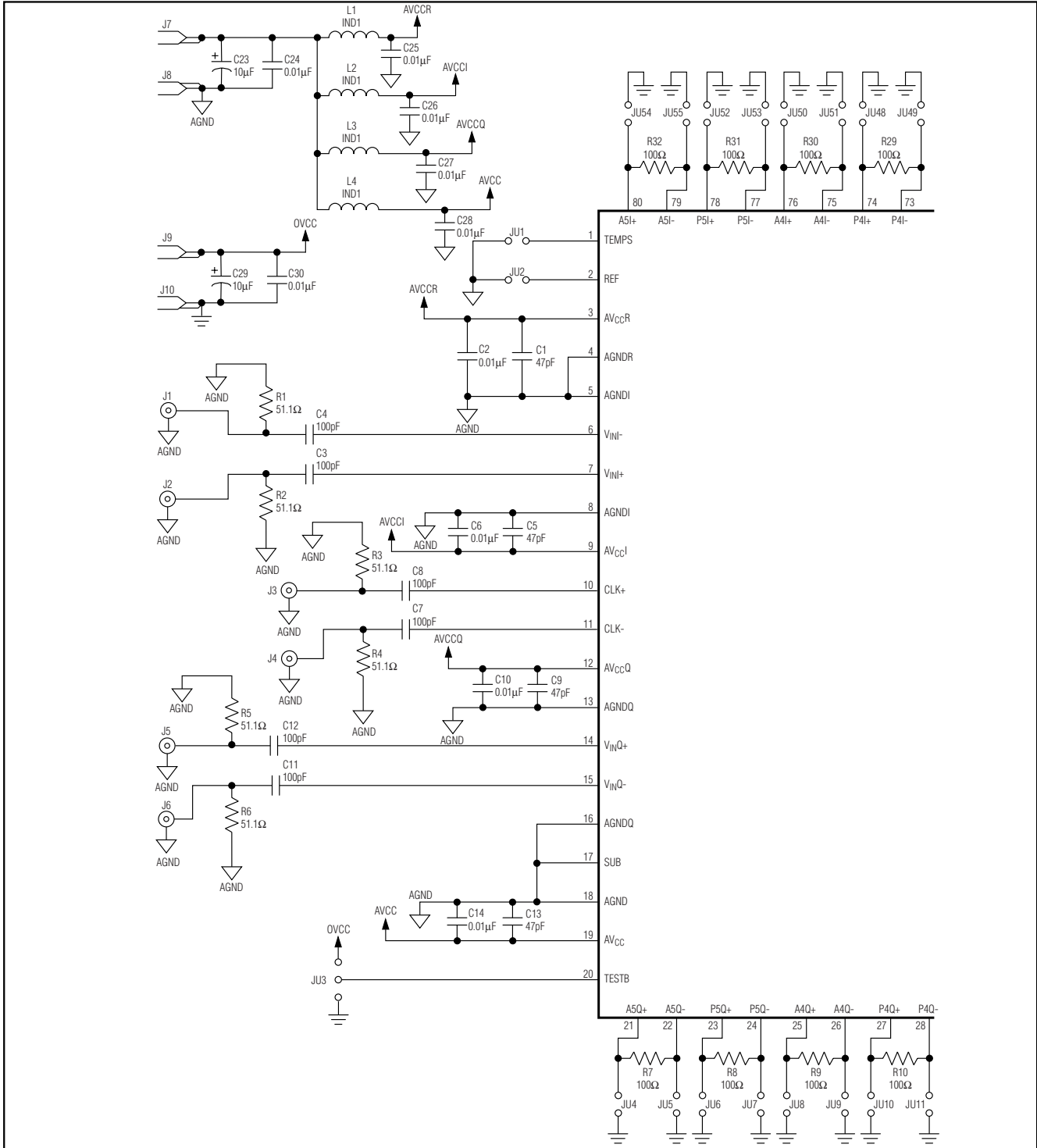

Figure 5a. MAX105 EV Kit Schematic

MAX105 Evaluation Kit

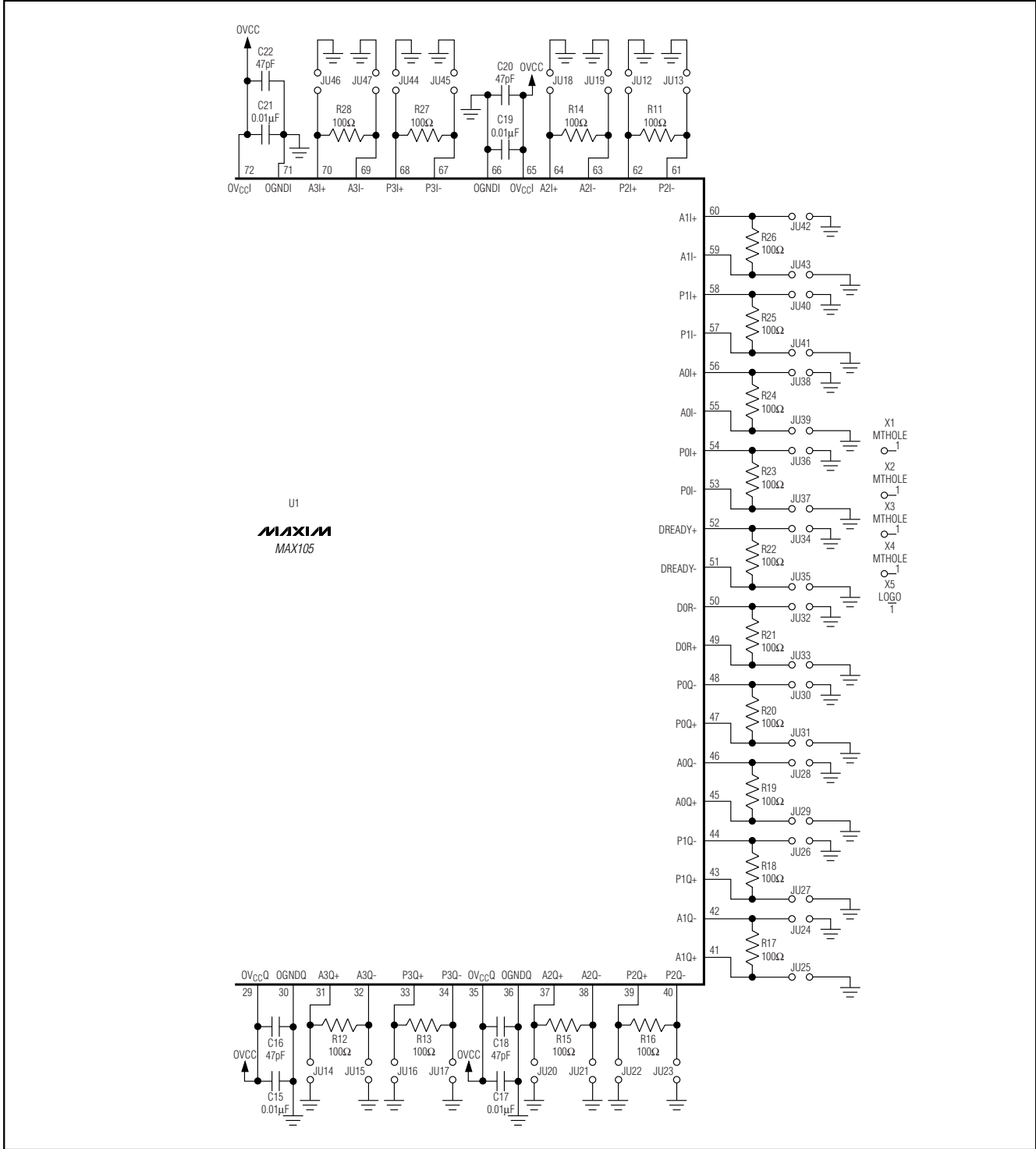

Figure 5b. MAX105 EV Kit Schematic (continued)

MAX105 Evaluation Kit

Evaluates: MAX105/MAX107

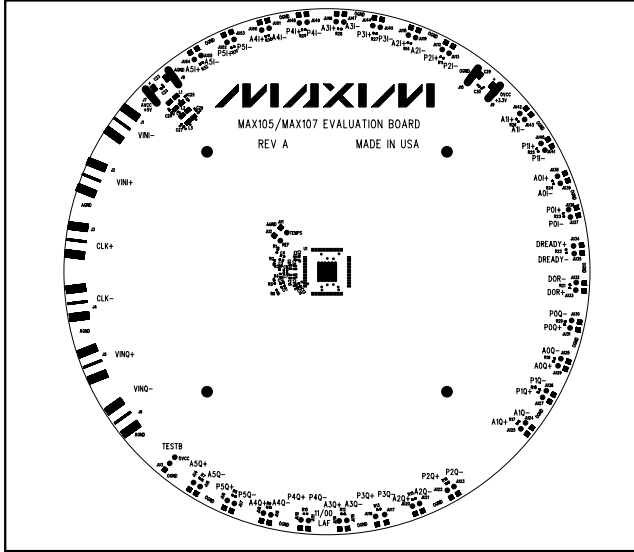

Figure 6. MAX105 EV Kit Component Placement Guide—Component Side

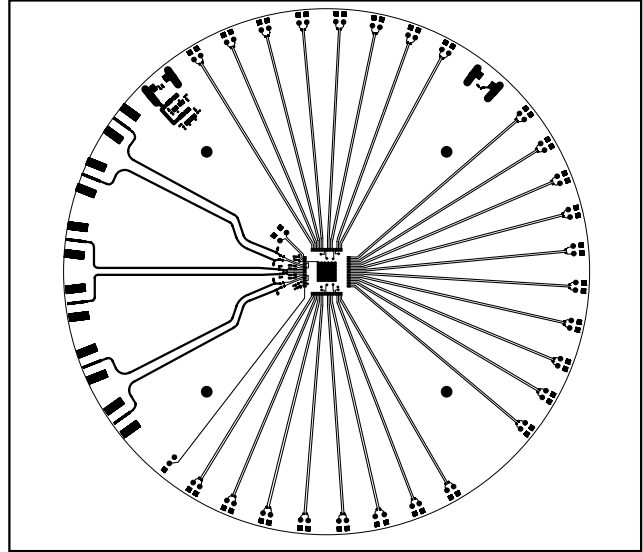

Figure 7. MAX105 EV Kit PC Board Layout—Component Side

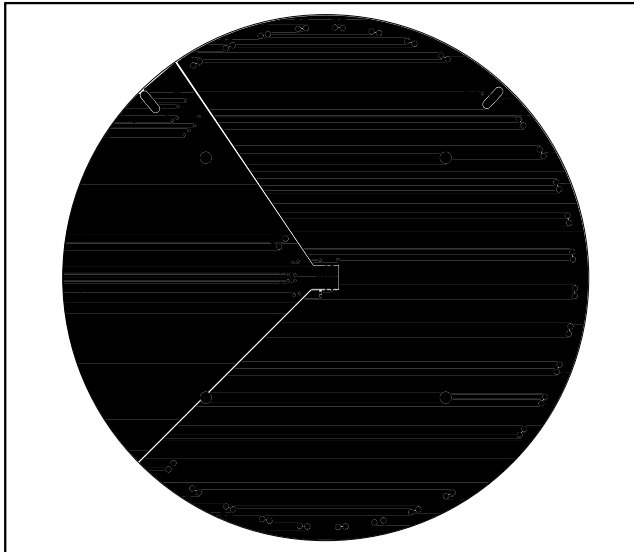

Figure 8. MAX105 EV Kit PC Board Layout—Inner Layer, Ground Plane

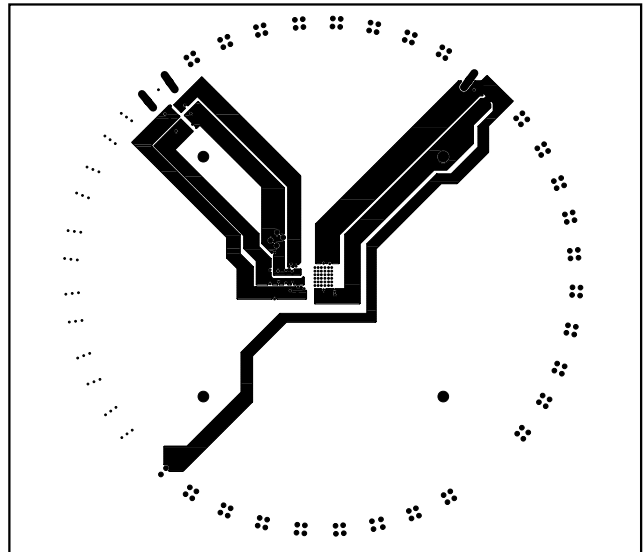

Figure 9. MAX105 EV Kit PC Board Layout—Inner Layer, Power Plane

MAX105 Evaluation Kit

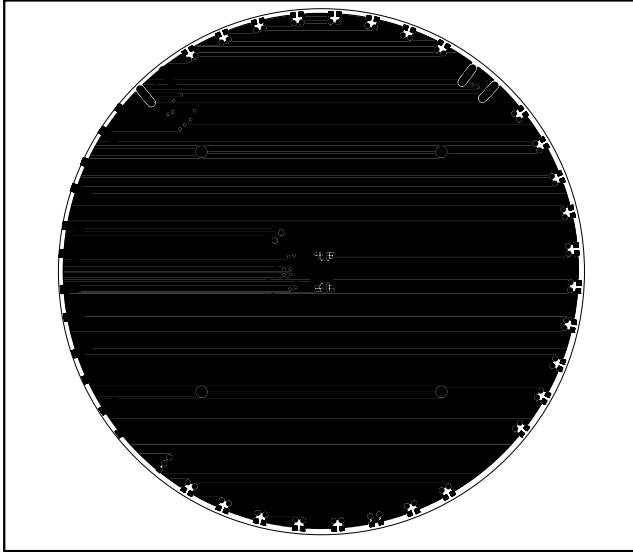

Figure 10. MAX105 EV Kit PC Board Layout—Solder Side

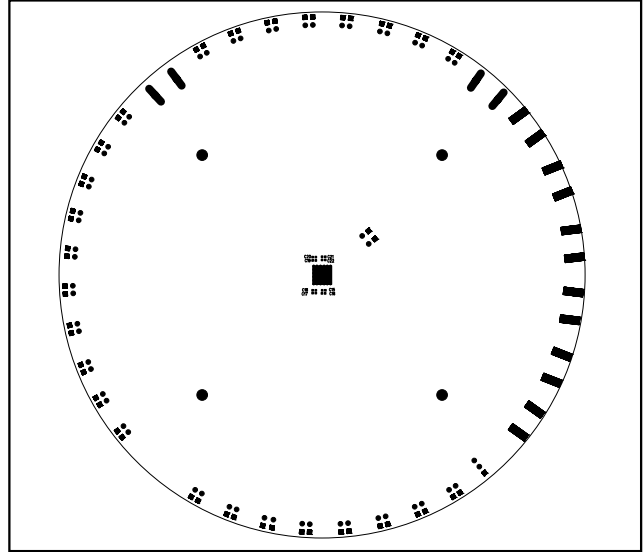

Figure 11. MAX105 EV Kit Component Placement Guide—Solder Side

Maxim cannot assume responsibility for use of any circuitry other than circuitry entirely embodied in a Maxim product. No circuit patent licenses are implied. Maxim reserves the right to change the circuitry and specifications without notice at any time.

10 _____ **Maxim Integrated Products, 120 San Gabriel Drive, Sunnyvale, CA 94086 408-737-7600**