



Chipsmall Limited consists of a professional team with an average of over 10 year of expertise in the distribution of electronic components. Based in Hongkong, we have already established firm and mutual-benefit business relationships with customers from,Europe,America and south Asia,supplying obsolete and hard-to-find components to meet their specific needs.

With the principle of “Quality Parts,Customers Priority,Honest Operation,and Considerate Service”,our business mainly focus on the distribution of electronic components. Line cards we deal with include Microchip,ALPS,ROHM,Xilinx,Pulse,ON,Everlight and Freescale. Main products comprise IC,Modules,Potentiometer,IC Socket,Relay,Connector.Our parts cover such applications as commercial,industrial, and automotives areas.

We are looking forward to setting up business relationship with you and hope to provide you with the best service and solution. Let us make a better world for our industry!



Contact us

Tel: +86-755-8981 8866 Fax: +86-755-8427 6832

Email & Skype: info@chipsmall.com Web: www.chipsmall.com

Address: A1208, Overseas Decoration Building, #122 Zhenhua RD., Futian, Shenzhen, China



MAXIM

Single-Supply, Low-Power, 2-Channel, Serial 8-Bit ADCs

MAX1108/MAX1109

General Description

The MAX1108/MAX1109 low-power, 8-bit, dual-channel, analog-to-digital converters (ADCs) feature an internal track/hold (T/H) voltage reference, clock, and serial interface. The MAX1108 is specified from +2.7V to +3.6V and consumes only 105 μ A. The MAX1109 is specified from +4.5V to +5.5V and consumes only 130 μ A. The analog inputs are software configurable, allowing unipolar/bipolar and single-ended/differential operation; battery monitoring capability is also included.

The full-scale analog input range is determined by the internal reference of +2.048V (MAX1108) or +4.096V (MAX1109), or by an externally applied reference ranging from 1V to V_{DD}. The MAX1108/MAX1109 also feature a software power-down mode that reduces power consumption to 0.5 μ A when the device is not in use. The 4-wire serial interface directly connects to SPI™, QSPI™, and MICROWIRE™ devices without external logic. Conversions up to 50ksps are performed using either the internal clock or an external serial-interface clock.

The MAX1108 and MAX1109 are available in a 10-pin μ MAX package with a footprint that is just 20% of an 8-pin plastic DIP.

Applications

Portable Data Logging
Hand-Held Measurement Devices
Medical Instruments
System Diagnostics
Solar-Powered Remote Systems
4–20mA-Powered Remote Systems
Receive-Signal Strength Indicators

Pin Configuration

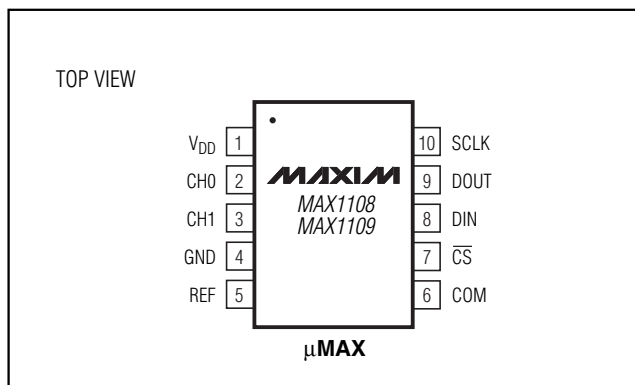

SPI and QSPI are trademarks of Motorola, Inc. MICROWIRE is a trademark of National Semiconductor Corp.

Features

- ◆ **Single Supply:** +2.7V to +3.6V (MAX1108)
+4.5V to +5.5V (MAX1109)
- ◆ **Low Power:** 105 μ A at +3V and 50ksps
0.5 μ A in Power-Down Mode
- ◆ **Software-Configurable Unipolar or Bipolar Inputs**
- ◆ **Input Voltage Range:** 0 to V_{DD}
- ◆ **Internal Track/Hold**
- ◆ **Internal Reference:** +2.048V (MAX1108)
+4.096V (MAX1109)
- ◆ **Reference Input Range:** 1V to V_{DD}
- ◆ **SPI/QSPI/MICROWIRE-Compatible Serial Interface**
- ◆ **V_{DD} Monitoring Mode**
- ◆ **Small 10-Pin μ MAX Package**

Ordering Information

PART	TEMP RANGE	PIN-PACKAGE
MAX1108CUB	0°C to +70°C	10 μ MAX
MAX1108EUB	-40°C to +85°C	10 μ MAX
MAX1109CUB	0°C to +70°C	10 μ MAX
MAX1109EUB	-40°C to +85°C	10 μ MAX

Functional Diagram

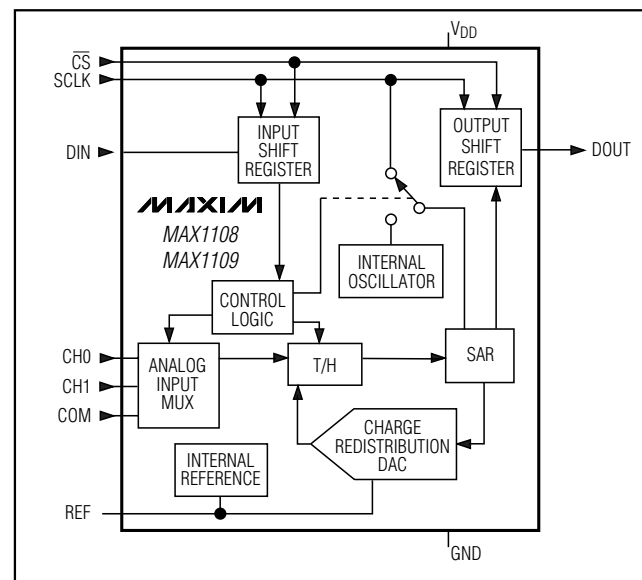
**MAXIM**

Maxim Integrated Products 1

For pricing, delivery, and ordering information, please contact Maxim/Dallas Direct! at 1-888-629-4642, or visit Maxim's website at www.maxim-ic.com.

Single-Supply, Low-Power, 2-Channel, Serial 8-Bit ADCs

ABSOLUTE MAXIMUM RATINGS

V_{DD} to GND-0.3V to +6V
 CH0, CH1, COM, REF, DOUT to GND-0.3V to (V_{DD} + 0.3V)
 DIN, SCLK, CS to GND-0.3V to +6V
 Continuous Power Dissipation (T_A = +70°C)
 10-pin μ MAX (derate 5.6mW/°C above +70°C)444mW

Operating Temperature Ranges

MAX110_CUB0°C to +70°C
 MAX110_EUB-40°C to +85°C
 Storage Temperature Range-65°C to +150°C
 Lead Temperature (soldering, 10s)+300°C

Stresses beyond those listed under "Absolute Maximum Ratings" may cause permanent damage to the device. These are stress ratings only, and functional operation of the device at these or any other conditions beyond those indicated in the operational sections of the specifications is not implied. Exposure to absolute maximum rating conditions for extended periods may affect device reliability.

ELECTRICAL CHARACTERISTICS—MAX1108

(V_{DD} = +2.7V to +3.6V; unipolar input mode; COM = GND, f_{SCLK} = 500kHz, external clock mode (50% duty cycle); 10 clocks/conversion cycle (50ksps); 1 μ F capacitor at REF, external +2.048V reference at REF; T_A = T_{MIN} to T_{MAX}; unless otherwise noted. Typical values are at T_A = +25°C.)

PARAMETER	SYMBOL	CONDITIONS	MIN	TYP	MAX	UNITS
DC ACCURACY						
Resolution			8			bits
Relative Accuracy (Note 1)	INL	V _{DD} = 2.7V to 3.6V		±0.15	±0.5	LSB
		V _{DD} = 5.5V (Note 2)		±0.2		
Differential Nonlinearity	DNL	No missing codes over temperature			±1	LSB
Offset Error		V _{DD} = 2.7V to 3.6V		±0.2	±1	LSB
		V _{DD} = 5.5V (Note 2)		±0.5		
Gain Error (Note 3)					±1	LSB
Gain Temperature Coefficient				±0.8		ppm/°C
Total Unadjusted Error	TUE	T _A = +25°C			±1	LSB
		T _A = T _{MIN} to T _{MAX}		±0.5		
Channel-to-Channel Offset Matching				±0.1		LSB
V _{DD} / 2 Sampling Accuracy				50		mV
DYNAMIC PERFORMANCE (10kHz sine-wave input, 2.048Vp-p, 50ksps, 500kHz external clock)						
Signal-to-Noise Plus Distortion	SINAD			49		dB
Total Harmonic Distortion (up to the 5th harmonic)	THD			-70		dB
Spurious-Free Dynamic Range	SFDR			68		dB
Small-Signal Bandwidth	BW-3dB	-3dB rolloff		1.5		MHz
Full-Power Bandwidth				0.8		MHz
ANALOG INPUTS						
Input Voltage Range (Note 4)	V _{CH}	Unipolar input, V _{COM} = 0	0		V _{REF}	V
		Bipolar input, V _{COM} or V _{CH1} = V _{REF} / 2, referenced to COM or CH1			±V _{REF} / 2	
Multiplexer Leakage Current		On/off-leakage current, V _{COM} or V _{CH} = 0 or V _{DD}		±0.01	±1	μ A
Input Capacitance	C _{IN}			18		pF

Single-Supply, Low-Power, 2-Channel, Serial 8-Bit ADCs

MAX1108/MAX1109

ELECTRICAL CHARACTERISTICS—MAX1108 (continued)

($V_{DD} = +2.7V$ to $+3.6V$; unipolar input mode; $COM = GND$, $f_{SCLK} = 500kHz$, external clock mode (50% duty cycle); 10 clocks/conversion cycle (50ksps); $1\mu F$ capacitor at REF, external $+2.048V$ reference at REF; $T_A = T_{MIN}$ to T_{MAX} ; unless otherwise noted. Typical values are at $T_A = +25^\circ C$.)

PARAMETER	SYMBOL	CONDITIONS	MIN	TYP	MAX	UNITS
TRACK/HOLD						
Conversion Time (Note 5)	t_{CONV}	Internal clock			35	μs
		External clock, 500kHz, 10 scilks/conv	20			
Track/Hold Acquisition Time	t_{ACQ}	External clock, 2MHz	1			μs
Aperture Delay				10		ns
Aperture Jitter				<50		ps
Internal Clock Frequency				400		kHz
External Clock Frequency Range			50		500	kHz
		For data transfer only			2	MHz
INTERNAL REFERENCE						
Output Voltage	V_{REF}		1.968	2.048	2.128	V
REF Short-Circuit Current	I_{REFSC}	(Note 6)		150		μA
REF Tempco				± 50		ppm/ $^\circ C$
Load Regulation		0 to 0.5mA (Note 7)		2.5		mV
Capacitive Bypass at REF			1			μF
EXTERNAL REFERENCE						
Input Voltage Range			1.0	$V_{DD} + 0.05$		V
Input Current		$+2.048V$ at REF, full scale, 500kHz external clock		1	20	μA
POWER REQUIREMENTS						
Supply Voltage	V_{DD}		2.7	3	5.5	V
Supply Current (Notes 2, 8)	I_{DD}	$V_{DD} = 2.7V$ to $3.6V$, $C_L = 10pF$	Internal reference	105	250	μA
			External reference	70		
		$V_{DD} = 5.5V$, $C_L = 10pF$	Internal reference	130		
			External reference	95		
		Power down, $V_{DD} = 2.7V$ to $3.6V$ (Note 9)	0.5	2.5		
Power-Supply Rejection (Note 10)	PSR	Full-scale input, $V_{DD} = 2.7V$ to $3.6V$		± 0.4	± 4	mV
DIGITAL INPUTS (\overline{DIN} , \overline{SCLK} , and \overline{CS})						
Threshold Voltage High	V_{IH}	$V_{DD} \leq 3.6V$			2	V
		$V_{DD} > 3.6V$			3	V
Threshold Voltage Low	V_{IL}		0.8			V
Input Hysteresis	V_{HYST}			0.2		V
Input Current High	I_{IH}				± 1	μA
Input Current Low	I_{IL}				± 1	μA
Input Capacitance	C_{IN}			15		pF

Single-Supply, Low-Power, 2-Channel, Serial 8-Bit ADCs

ELECTRICAL CHARACTERISTICS—MAX1108 (continued)

($V_{DD} = +2.7V$ to $+3.6V$; unipolar input mode; $COM = GND$, $f_{SCLK} = 500kHz$, external clock mode (50% duty cycle); 10 clocks/conversion cycle (50ksp/s); $1\mu F$ capacitor at REF, external $+2.048V$ reference at REF; $T_A = T_{MIN}$ to T_{MAX} ; unless otherwise noted. Typical values are at $T_A = +25^\circ C$.)

PARAMETER	SYMBOL	CONDITIONS	MIN	TYP	MAX	UNITS
DIGITAL OUTPUT (DOUT)						
Output High Voltage	V_{OH}	$I_{SOURCE} = 0.5mA$	$V_{DD} - 0.5$			V
Output Low Voltage	V_{OL}	$I_{SINK} = 5mA$			0.4	V
		$I_{SINK} = 16mA$			0.8	V
Three-State Leakage Current	I_L	$\overline{CS} = V_{DD}$	± 0.01		± 10	μA
Three-State Output Capacitance	C_{OUT}	$\overline{CS} = V_{DD}$	15			pF
TIMING CHARACTERISTICS (Figures 8, 9, and 10)						
Acquisition Time	t_{ACQ}		1.0			μs
DIN to SCLK Setup Time	t_{DS}		100			ns
DIN to SCLK Hold Time	t_{DH}		0			ns
SCLK Fall to Output Data Valid	t_{DO}	Figure 1, $C_{LOAD} = 100pF$	20		200	ns
\overline{CS} Fall to Output Enable	t_{DV}	Figure 1, $C_{LOAD} = 100pF$			240	ns
\overline{CS} Rise to Output Disable	t_{TR}	Figure 2, $C_{LOAD} = 100pF$			240	ns
\overline{CS} to SCLK Rise Setup	t_{CSS}		100			ns
\overline{CS} to SCLK Rise Hold	t_{CSH}		0			ns
SCLK Pulse Width High	t_{CH}		200			ns
SCLK Pulse Width Low	t_{CL}		200			ns
Wake-Up Time	t_{WAKE}	External reference	20			μs
		Internal reference (Note 11)	12			ms

ELECTRICAL CHARACTERISTICS—MAX1109

($V_{DD} = +4.5V$ to $+5.5V$; unipolar input mode; $COM = GND$, $f_{SCLK} = 500kHz$, external clock (50% duty cycle); 10 clocks/conversion cycle (50ksp/s); $1\mu F$ capacitor at REF, external $+4.096V$ reference at REF; $T_A = T_{MIN}$ to T_{MAX} ; unless otherwise noted. Typical values are at $T_A = +25^\circ C$.)

PARAMETER	SYMBOL	CONDITIONS	MIN	TYP	MAX	UNITS
DC ACCURACY						
Resolution			8			bits
Relative Accuracy (Note 1)	INL	$V_{DD} = 4.5V$ to $5.5V$	± 0.15		± 0.5	LSB
Differential Nonlinearity	DNL	No missing codes over temperature			± 1	LSB
Offset Error		$V_{DD} = 4.5V$ to $5.5V$	± 0.2		± 1	LSB
Gain Error (Note 3)					± 1	LSB
Gain Temperature Coefficient			± 0.8			ppm/ $^\circ C$
Total Unadjusted Error	TUE	$T_A = +25^\circ C$			± 1	LSB
		$T_A = T_{MIN}$ to T_{MAX}			± 0.5	
Channel-to-Channel Offset Matching			± 0.1			LSB
$V_{DD} / 2$ Sampling Accuracy			50			mV

Single-Supply, Low-Power, 2-Channel, Serial 8-Bit ADCs

MAX1108/MAX1109

ELECTRICAL CHARACTERISTICS—MAX1109 (continued)

($V_{DD} = +4.5V$ to $+5.5V$; unipolar input mode; $COM = GND$, $f_{SCLK} = 500kHz$, external clock (50% duty cycle); 10 clocks/conversion cycle (50ksps); $1\mu F$ capacitor at REF, external $+4.096V$ reference at REF; $T_A = T_{MIN}$ to T_{MAX} ; unless otherwise noted. Typical values are at $T_A = +25^\circ C$.)

PARAMETER	SYMBOL	CONDITIONS	MIN	TYP	MAX	UNITS
DYNAMIC PERFORMANCE (10kHz sine-wave input, 4.096Vp-p, 50ksps, 500kHz external clock)						
Signal-to-Noise Plus Distortion	SINAD			49		dB
Total Harmonic Distortion (up to the 5th harmonic)	THD			-70		dB
Spurious Free Dynamic Range	SFDR			68		dB
Small-Signal Bandwidth	BW-3dB	-3dB rolloff		1.5		MHz
Full-Power Bandwidth				0.8		MHz
ANALOG INPUTS						
Input Voltage Range (Note 4)	$V_{CH_}$	Unipolar input, $V_{COM} = 0$	0	V_{REF}		V
		Bipolar input, V_{COM} or $V_{CH1} = V_{REF} / 2$, referenced to COM or CH1		$\pm V_{REF} / 2$		
Multiplexer Leakage Current		On/off-leakage current, $V_{CH} = 0$ or V_{DD}		± 0.01	± 1	μA
Input Capacitance	C_{IN}			18		pF
TRACK/HOLD						
Conversion Time (Note 5)	t_{CONV}	Internal clock			35	μs
		External clock, 500kHz, 10 sclks/conv	20			
Track/Hold Acquisition Time	t_{ACQ}	External clock, 2MHz	1			μs
Aperture Delay				10		ns
Aperture Jitter				<50		ps
Internal Clock Frequency				400		kHz
External Clock Frequency Range			50		500	kHz
		For data transfer only			2	MHz
INTERNAL REFERENCE						
Output Voltage	V_{REF}		3.936	4.096	4.256	V
REF Short-Circuit Current	I_{REFSC}			5		mA
REF Tempco		0 to 0.5mA (Note 7)		± 50		ppm/ $^\circ C$
Load Regulation				2.5		mV
Capacitive Bypass at REF			1			μF
EXTERNAL REFERENCE						
Input Voltage Range			1.0	$V_{DD} + 0.05$		V
Input Current		+4.096V at REF, full scale, 500kHz external clock		1	20	μA

Single-Supply, Low-Power, 2-Channel, Serial 8-Bit ADCs

ELECTRICAL CHARACTERISTICS—MAX1109 (continued)

($V_{DD} = +4.5V$ to $+5.5V$; unipolar input mode; $COM = GND$, $f_{SCLK} = 500kHz$, external clock (50% duty cycle); 10 clocks/conversion cycle (50ksps); $1\mu F$ capacitor at REF, external $+4.096V$ reference at REF; $T_A = T_{MIN}$ to T_{MAX} ; unless otherwise noted. Typical values are at $T_A = +25^\circ C$.)

PARAMETER	SYMBOL	CONDITIONS	MIN	TYP	MAX	UNITS	
POWER REQUIREMENTS							
Supply Voltage	V_{DD}		4.5	5	5.5	V	
Supply Current (Notes 2, 8)	I_{DD}	$V_{DD} = 4.5V$ to $5.5V$, $C_L = 10pF$, full-scale input	Internal reference		130	250	μA
			External reference		95		
		Power down, $V_{DD} = 4.5V$ to $5.5V$ (Note 9)		0.5	2.5		
Power-Supply Rejection (Note 10)	PSR	External reference = $+4.096V$, full-scale input, $V_{DD} = 4.5V$ to $5.5V$		± 0.4	± 4	mV	
DIGITAL INPUTS (DIN, \overline{SCLK} , and \overline{CS})							
Threshold Voltage High	V_{IH}				3	V	
Threshold Voltage Low	V_{IL}		0.8			V	
Input Hysteresis	V_{HYST}			0.2		V	
Input Current High	I_{IH}				± 1	μA	
Input Current Low	I_{IL}				± 1	μA	
Input Capacitance	C_{IN}			15		pF	
DIGITAL OUTPUT (DOUT)							
Output High Voltage	V_{OH}	$I_{SOURCE} = 0.5mA$	$V_{DD} - 0.5$			V	
Output Low Voltage	V_{OL}	$I_{SINK} = 5mA$		0.4		V	
		$I_{SINK} = 16mA$	0.8				
Three-State Leakage Current	I_L	$\overline{CS} = V_{DD}$		± 0.01	± 10	μA	
Three-State Output Capacitance	C_{OUT}	$\overline{CS} = V_{DD}$		15		pF	
TIMING CHARACTERISTICS (Figures 8, 9, and 10)							
Acquisition Time	t_{ACQ}		1.0			μs	
DIN to SCLK Setup Time	t_{DS}		100			ns	
DIN to SCLK Hold Time	t_{DH}		0			ns	
SCLK Fall to Output Data Valid	t_{DO}	Figure 1, $C_{LOAD} = 100pF$	20		200	ns	
\overline{CS} Fall to Output Enable	t_{DV}	Figure 1, $C_{LOAD} = 100pF$			240	ns	
\overline{CS} Rise to Output Disable	t_{TR}	Figure 2, $C_{LOAD} = 100pF$			240	ns	

Single-Supply, Low-Power, 2-Channel, Serial 8-Bit ADCs

MAX1108/MAX1109

ELECTRICAL CHARACTERISTICS—MAX1109 (continued)

($V_{DD} = +4.5V$ to $+5.5V$; unipolar input mode; COM = GND, $f_{SCLK} = 500kHz$, external clock (50% duty cycle); 10 clocks/conversion cycle (50ksps); $1\mu F$ capacitor at REF, external $+4.096V$ reference at REF; $T_A = T_{MIN}$ to T_{MAX} ; unless otherwise noted. Typical values are at $T_A = +25^\circ C$.)

PARAMETER	SYMBOL	CONDITIONS	MIN	TYP	MAX	UNITS
\overline{CS} to SCLK Rise Setup	t_{CSS}		100			ns
\overline{CS} to SCLK Rise Hold	t_{CSH}		0			ns
SCLK Pulse Width High	t_{CH}		200			ns
SCLK Pulse Width Low	t_{CL}		200			ns
Wake-Up Time	t_{WAKE}	External reference		20		μs
		Internal reference (Note 11)		12		ms

- Note 1:** Relative accuracy is the deviation of the analog value at any code from its theoretical value after the full-scale range has been calibrated.
- Note 2:** See *Typical Operating Characteristics*.
- Note 3:** $V_{REF} = +2.048V$ (MAX1108), $V_{REF} = +4.096V$ (MAX1109), offset nulled.
- Note 4:** Common-mode range (CH0, CH1, COM) GND to V_{DD} .
- Note 5:** Conversion time defined as the number of clock cycles times the clock period; clock has 50% duty cycle (Figures 6 and 8).
- Note 6:** REF supplies typically 2.5mA under normal operating conditions.
- Note 7:** External load should not change during the conversion for specified accuracy.
- Note 8:** Power consumption with CMOS levels.
- Note 9:** Power-down test performed using the following sequence 1) \overline{SHDN} 5bit = 0 in the configuration register; 2) Wait for 10 SCLK cycles to complete current conversion; 3) Measure shutdown current with \overline{CS} , SCLK, $D_{IN} = V_{DD}$ or GND.
- Note 10:** Measured as $|V_{FS}(2.7V) - V_{FS}(3.6V)|$ for MAX1108, and measured as $|V_{FS}(4.5V) - V_{FS}(5.5V)|$ for MAX1109.
- Note 11:** $1\mu F$ at REF, internal reference settling to 0.5LSB.

Typical Operating Characteristics

($V_{DD} = +3.0V$ (MAX1108), $V_{DD} = +5.0V$ (MAX1109); external conversion mode; $f_{SCLK} = 500kHz$; 50ksps; external reference; $1\mu F$ at REF; $T_A = +25^\circ C$; unless otherwise noted.)

SUPPLY CURRENT vs. SUPPLY VOLTAGE

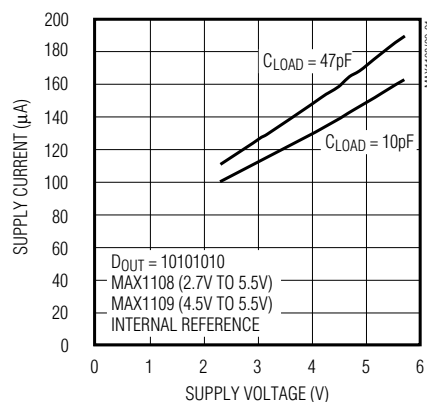

SUPPLY CURRENT vs. TEMPERATURE

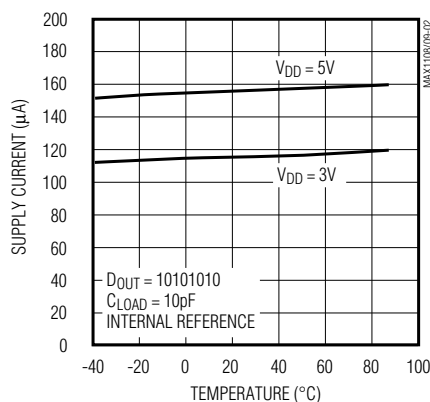

SHUTDOWN SUPPLY CURRENT vs. SUPPLY VOLTAGE

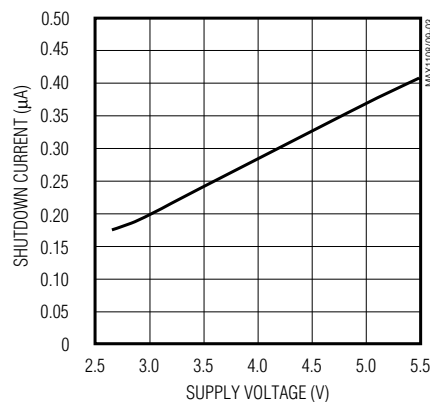

Single-Supply, Low-Power, 2-Channel, Serial 8-Bit ADCs

Typical Operating Characteristics (continued)

(V_{DD} = +3.0V (MAX1108), V_{DD} = +5.0V (MAX1109); external conversion mode; f_{SCLK} = 500kHz; 50ksp/s; external reference; 1μF at REF; T_A = +25°C; unless otherwise noted.)

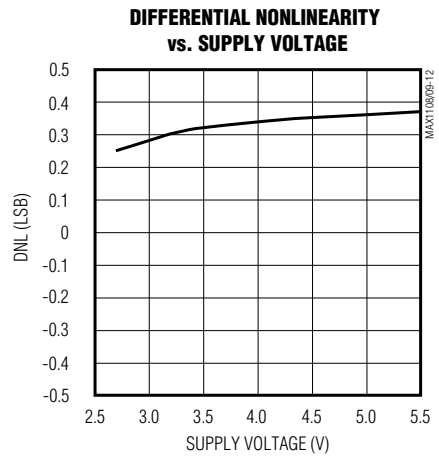
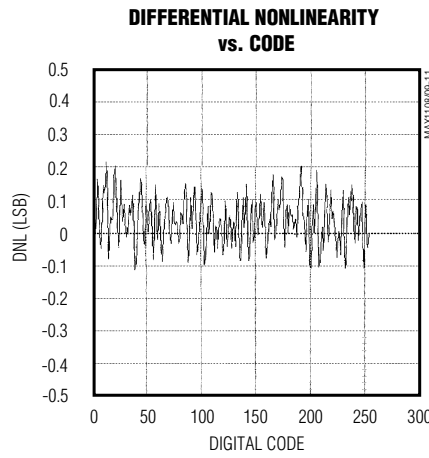
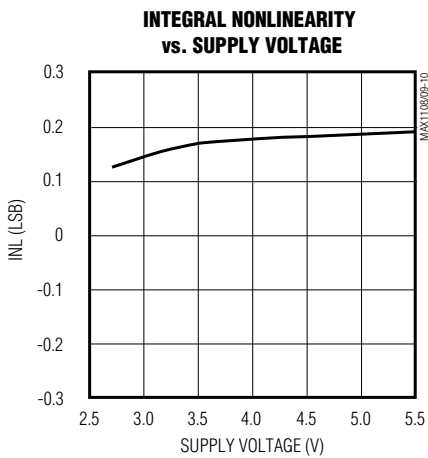
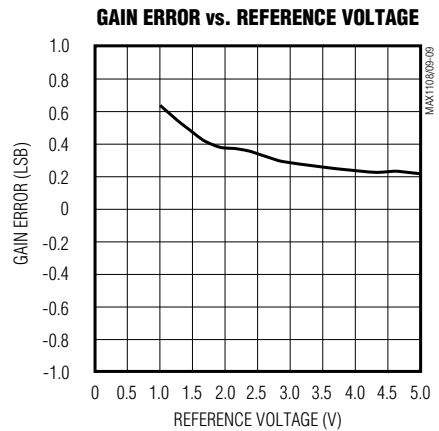
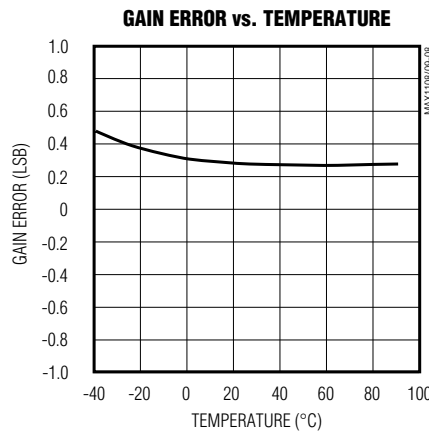
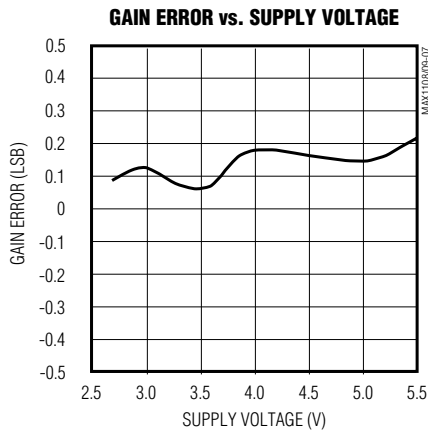
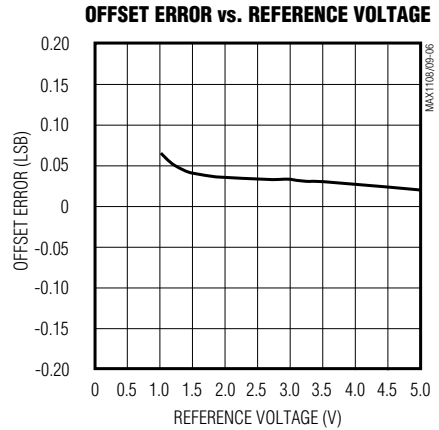
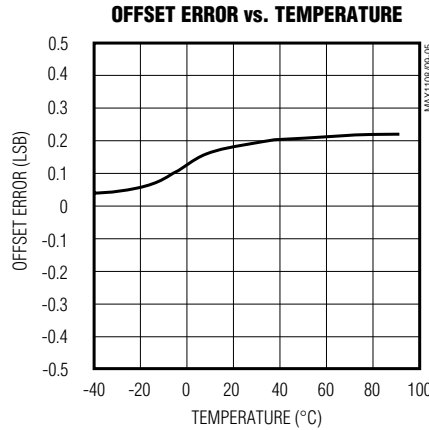
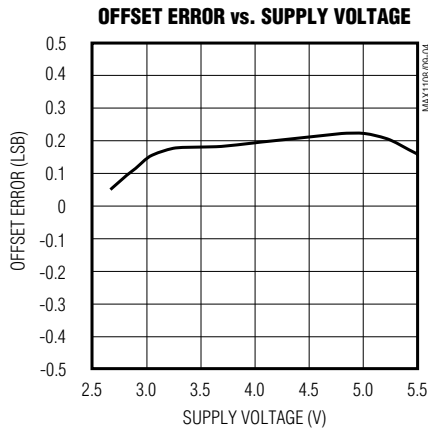

Single-Supply, Low-Power, 2-Channel, Serial 8-Bit ADCs

Typical Operating Characteristics (continued)

(V_{DD} = +3.0V (MAX1108), V_{DD} = +5.0V (MAX1109); external conversion mode; f_{SCLK} = 500kHz; 50ksps; external reference; 1μF at REF; T_A = +25°C; unless otherwise noted.)

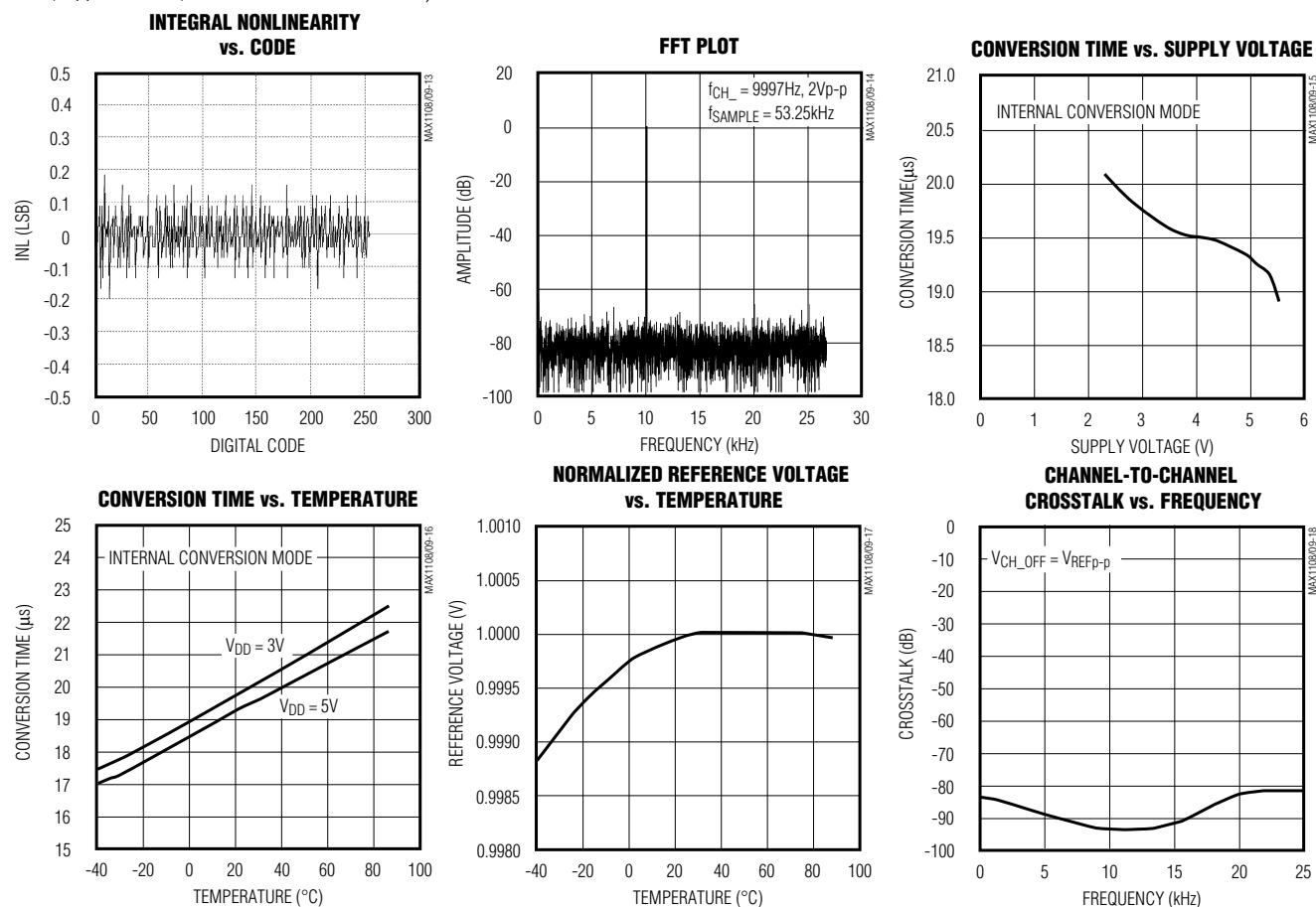

Pin Description

PIN	NAME	FUNCTION
1	V _{DD}	Positive Supply Voltage
2, 3	CH0, CH1	Sampling Analog Inputs
4	GND	Ground
5	REF	Reference voltage for analog-to-digital conversion (internal or external reference). Reference input for external reference. Bypass internal reference with 1μF capacitor to GND.
6	COM	Common reference for analog inputs. Sets zero-code voltage in single-ended mode. Must be stable to ±0.5LSB during conversion.
7	$\overline{\text{CS}}$	Active-Low Chip Select. Data is not clocked into DIN unless $\overline{\text{CS}}$ is low. When $\overline{\text{CS}}$ is high, DOUT is high impedance.
8	DIN	Serial Data Input. Data is clocked in at the rising edge of SCLK.
9	DOUT	Serial Data Output. Data is clocked out on the falling edge of SCLK. High impedance when $\overline{\text{CS}}$ is high.
10	SCLK	Serial Clock Input. Clocks data in and out of serial interface. In external clock mode, SCLK also sets the conversion speed.

Single-Supply, Low-Power, 2-Channel, Serial 8-Bit ADCs

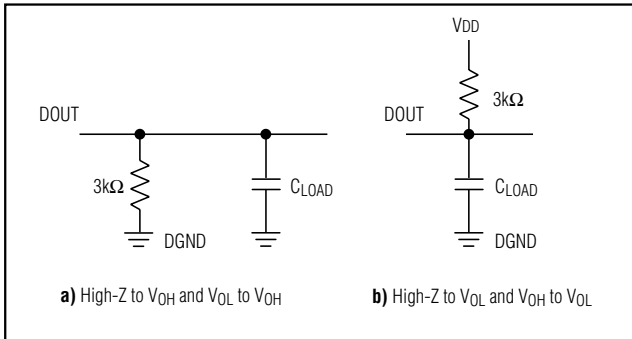

Figure 1. Load Circuits for Enable Time

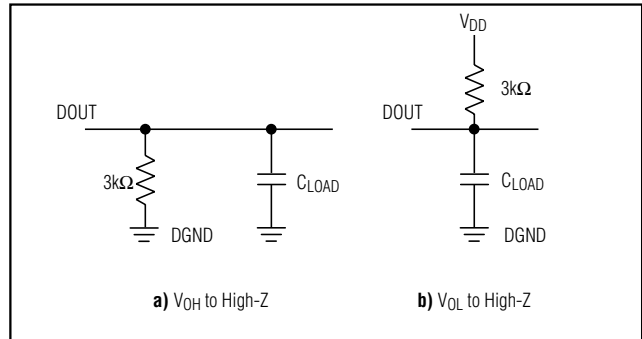

Figure 2. Load Circuits for Disable Time

Detailed Description

The MAX1108/MAX1109 analog-to-digital converters (ADCs) use a successive-approximation conversion technique and input track/hold (T/H) circuitry to convert an analog signal to an 8-bit digital output. A flexible serial interface provides easy interface to microprocessors (μ Ps). No external hold capacitors are required. All of the MAX1108/MAX1109 operating modes are software-configurable: internal or external reference, internal or external conversion clock, single-ended unipolar or pseudo-differential unipolar/bipolar conversion, and power down (Table 1).

Analog Inputs

Track/Hold

The input architecture of the ADCs is illustrated in the equivalent-input circuit of Figure 4 and is composed of the T/H, the input multiplexer, the input comparator, the switched capacitor DAC, the reference, and the auto-zero rail.

The analog-inputs configuration is determined by the control-byte through the serial interface as shown in Table 2 (see *Modes of Operation* section and Table 1). The eight modes of operation include single-ended, pseudo-differential, unipolar/bipolar, and a V_{DD} monitoring mode. During acquisition and conversion, only one of the switches in Figure 4 is closed at any time.

The T/H enters its tracking mode on the falling clock edge after bit 4 (SEL0) of the control byte has been shifted in. It enters its hold mode on the falling edge after the bit 2 (I/EREF) of the control byte has been shifted in.

For example, If CH0 and COM are chosen (SEL2 = SEL1 = SEL0 = 1) for conversion, CH0 is defined as the sampled input (SI), and COM is defined as the reference input (RI). During acquisition mode, the CH0 switch and the T/H switch are closed, charging the

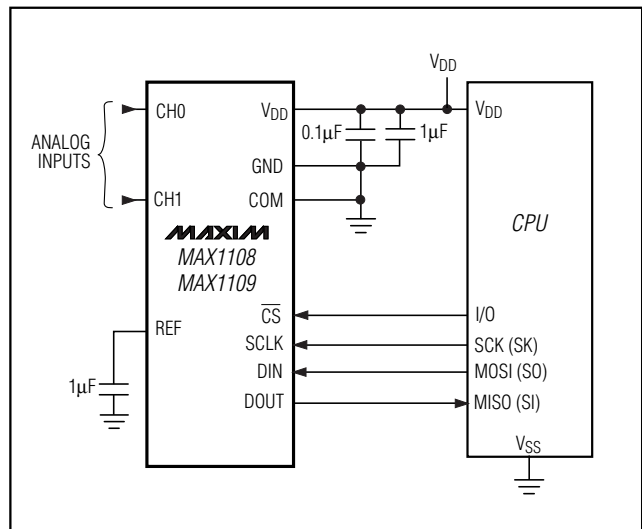

Figure 3. Typical Operating Circuit

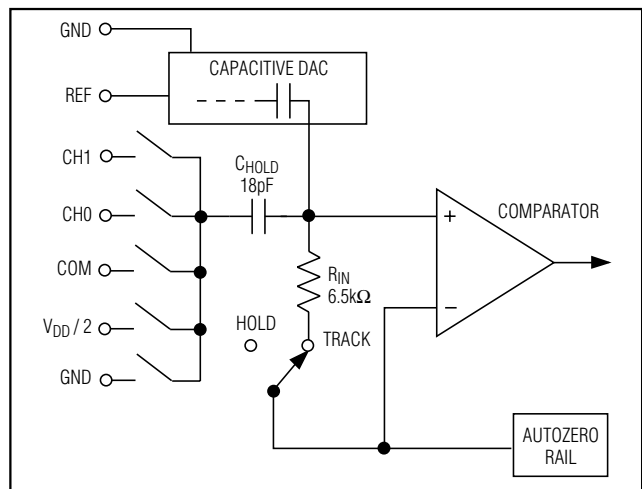

Figure 4. Equivalent Input Circuit

Single-Supply, Low-Power, 2-Channel, Serial 8-Bit ADCs

holding capacitor CHOLD through R_{IN}. At the end of acquisition the T/H switch opens and CHOLD is connected to COM, retaining charge on CHOLD as a sample of the signal at CH0, and the difference between CH0 and COM is the converted signal. Once conversion is complete, the T/H returns immediately to its tracking mode. This procedure holds for the different combinations summarized in Table 2.

The time available for the T/H to acquire an input signal (t_{ACQ}) is determined by the clock frequency, and is 1μs at the maximum clock frequency of 2MHz. The acquisition time is also the minimum time needed for the signal to be acquired. It is calculated by:

$$t_{ACQ} = 6(R_S + R_{IN})18pF$$

where R_{IN} = 6.5kΩ, R_S = the source impedance of the input signal, and t_{ACQ} is never less than 1μs. Note that source impedances below 2.7kΩ do not significantly affect the AC performance of the ADC at the maximum clock speed. If the input-source impedance is higher than 3kΩ, the clock speed must be reduced accordingly.

Pseudo-Differential Input

The MAX1108/MAX1109 input configuration is pseudo-differential to the extent that only the signal at the sampled input (SI) is stored in the holding capacitor (CHOLD). The reference input (RI) must remain stable within ±0.5LSB (±0.1LSB for best results) in relation to GND during a conversion. Sampled input and reference input configuration is determined by bit6–bit4 (SEL2–SELO) of the control byte (Table 2).

If a varying signal is applied at the selected reference input, its amplitude and frequency need to be limited. The following equations determine the relationship between the maximum signal amplitude and its frequency to maintain ±0.5LSB accuracy:

Assuming a sinusoidal signal at the reference input

$$v_{RI} = V_{RI}\sin(2\pi ft)$$

the maximum voltage variation is determined by:

$$\max \frac{dv_{RI}}{dt} = 2\pi f \cdot v_{RI} \leq \frac{1 \text{ LSB}}{t_{CONV}} = \frac{V_{REF}}{2^8 t_{CONV}}$$

a 60Hz signal at RI with an amplitude of 1.2V will generate a ±0.5LSB of error. This is with a 35μs conversion time (maximum t_{CONV} in internal conversion mode) and a reference voltage of +4.096V. When a DC reference voltage is used at RI, connect a 0.1μF capacitor to GND to minimize noise at the input.

The input configuration selection also determines unipolar or bipolar conversion mode. The common-mode input range of CH0, CH1, and COM is 0 to +V_{DD}. In unipolar mode, full scale is achieved when (SI - RI) = V_{REF}; in bipolar mode, full scale is achieved when |(SI - RI)| = V_{REF} / 2. In unipolar mode, SI must be higher than RI; in bipolar mode, SI can span above and below RI provided that it is within the common-mode range.

Conversion Process

The comparator negative input is connected to the auto-zero rail. Since the device requires only a single supply, the ZERO node at the input of the comparator equals V_{DD}/2. The capacitive DAC restores node ZERO to have 0V difference at the comparator inputs within the limits of 8-bit resolution. This action is equivalent to transferring a charge of 18pF(V_{IN+} - V_{IN-}) from CHOLD to the binary-weighted capacitive DAC which, in turn, forms a digital representation of the analog-input signal.

Input Voltage Range

Internal protection diodes that clamp the analog input to V_{DD} and AGND allow the channel input pins (CH0, CH1, and COM) to swing from (AGND - 0.3V) to (V_{DD} + 0.3V) without damage. However, for accurate conversions, the inputs must not exceed (V_{DD} + 50mV) or be less than (GND - 50mV).

If the analog input voltage on an “off” channel exceeds 50mV beyond the supplies, the current should be limited to 2mA to maintain conversion accuracy on the “on” channel.

The MAX1108/MAX1109 input range is from 0 to V_{DD}; unipolar or bipolar conversion is available. In unipolar mode, the output code is invalid (code zero) when a negative input voltage (or a negative differential input voltage) is applied. The reference input-voltage range at REF is from 1V to (V_{DD} + 50mV.)

Input Bandwidth

The ADC's input tracking circuitry has a 1.5MHz small-signal bandwidth, so it is possible to digitize high-speed transient events and measure periodic signals with bandwidths exceeding the ADC's sampling rate by using undersampling techniques. To avoid high-frequency signals being aliased into the frequency band of interest, anti-alias filtering is recommended.

Serial Interface

The MAX1108/MAX1109 have a 4-wire serial interface. The CS, DIN, and SCLK inputs are used to control the device, while the three-state DOUT pin is used to access the result of conversion.

Single-Supply, Low-Power, 2-Channel, Serial 8-Bit ADCs

The serial interface provides easy connection to microcontrollers with SPI, QSPI and MICROWIRE serial interfaces at clock rates up to 2MHz. For SPI and QSPI, set $CPOLE = CPHA = 0$ in the SPI control registers of the microcontroller. Figure 5 shows the MAX1108/MAX1109 common serial-interface connections.

Digital Inputs

The logic levels of the MAX1108/MAX1109 digital input are set to accept voltage levels from both +3V and +5V systems, regardless of the supply voltages. Input data (control byte) is clocked in at the DIN pin on the rising edge of serial clock (SCLK). \overline{CS} is the standard chip-select signal which enables communication with the device. SCLK is used to clock data in and out of serial interface. In external clock mode, SCLK also sets the conversion speed.

Digital Output

Output data is read on the rising edge of SCLK at DOUT, MSB first (D7). In unipolar input mode, the output is straight binary. For bipolar input mode, the output is twos-complement (see *Transfer Function* section).

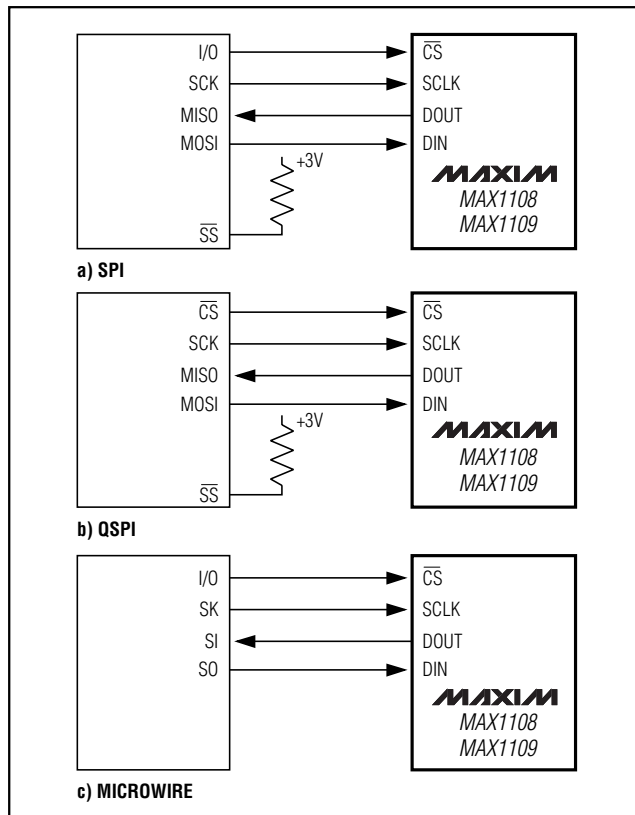

Figure 5. Common Serial-Interface Connections

DOUT is active when \overline{CS} is low and high impedance when \overline{CS} is high. DOUT does not accept external voltages greater than V_{DD} . In external-clock mode, data is clocked out at the maximum clock rate of 500kHz while conversion is in progress. In internal-clock mode, data can be clocked out at up to 2MHz clock rate.

Modes of Operation

The MAX1108/MAX1109 feature single-ended or pseudo-differential operation in unipolar or bipolar configuration. The device is programmed through the input control-byte at the DIN pin of the serial interface (Table 1). Table 2 shows the analog-input configuration and Table 3 shows the input-voltage ranges in unipolar and bipolar configuration.

How to Start a Conversion

A conversion is started by clocking a control byte into DIN. With \overline{CS} low, each rising edge on SCLK clocks a bit from DIN into the MAX1108/MAX1109's internal shift register. After \overline{CS} falls, the first arriving logic "1" bit at DIN defines the MSB of the control byte. Until this first start bit arrives, any number of logic "0" bits can be clocked into DIN with no effect. Table 1 shows the control-byte format.

Using the *Typical Operating Circuit* (Figure 3), the simplest software interface requires two 8-bit transfers to perform a conversion (one 8-bit transfer to configure the ADC, and one 8-bit transfer to clock out the 8-bit conversion result). Figure 6 shows a single-conversion timing diagram using external clock mode.

Clock Modes

The MAX1108/MAX1109 can use either an external serial clock or the internal clock to perform the successive-approximation conversion. In both clock modes, the external clock shifts data in and out of the devices. Bit 3 of control-byte (I/ECLK) programs the clock mode. Figure 8 shows the timing characteristics common to both modes.

External Clock

In external clock mode, the external clock not only shifts data in and out, it also drives the analog-to-digital conversion steps. In this mode the clock frequency must be between 50kHz and 500kHz. Single-conversion timing using an external clock begins with a falling edge on \overline{CS} . When this occurs, DOUT leaves the high impedance state and goes low. The first "1" clocked into DIN by SCLK after \overline{CS} is set low is considered as the start bit. The next seven clocks latch in the rest of the control byte. On the falling edge of the fourth clock, track mode is enabled, and on the falling edge of the sixth clock, acquisition is complete and conversion is

Single-Supply, Low-Power, 2-Channel, Serial 8-Bit ADCs

MAX1108/MAX1109

Table 1. Control Byte Format

BIT 7 (MSB)	BIT 6	BIT 5	BIT 4	BIT 3	BIT 2	BIT 1	BIT 0 (LSB)
START	SEL2	SEL1	SEL0	I/ECLK	I/EREF	$\overline{\text{REFSHDN}}$	$\overline{\text{SHDN}}$

BIT	NAME	DESCRIPTION
7 (MSB)	START	The first logic "1" bit after $\overline{\text{CS}}$ goes low defines the beginning of the control byte.
6 5 4	SEL2 SEL1 SEL0	Selects the mode of operation (Table 2).
3	I/ECLK	1 = external clock, 0 = internal clock. The SAR can be driven by the internal oscillator, or with the SCLK signal.
2	I/EREF	1 = internal reference, 0 = external reference. Internal reference selects +2.048V (MAX1108) or +4.096V (MAX1109), or an external reference can be applied to the REF pin.
1	$\overline{\text{REFSHDN}}$	1 = operational (if I / EREF = 1), 0 = reference shutdown. When using an external reference, power consumption can be minimized by powering down the internal reference separately (I / EREF = 0). $\overline{\text{REFSHDN}}$ must be set to 0 when $\overline{\text{SHDN}} = 0$.
0 (LSB)	$\overline{\text{SHDN}}$	1 = operational, 0 = power down. For a full power down set $\overline{\text{REFSHDN}} = \overline{\text{SHDN}} = 0$. (See <i>Power-Down Mode</i> section.)

Table 2. Conversion Configuration

SEL2	SEL1	SEL0	SAMPLED INPUT (SI)	REFERENCE INPUT (RI)	CONVERSION MODE
1	1	1	CH0	COM	Unipolar
1	1	0	CH1	COM	Unipolar
1	0	1	CH0	GND	Unipolar
1	0	0	CH1	GND	Unipolar
0	1	1	CH0	COM	Bipolar
0	1	0	CH1	COM	Bipolar
0	0	1	CH0	CH1	Bipolar
0	0	0	V _{DD} / 2	GND	Unipolar

Table 3. Full- and Zero-Scale Voltages

UNIPOLAR MODE		BIPOLAR MODE		
Zero Scale	Full Scale	Negative Full Scale	Zero Scale	Positive Full Scale
RI*	RI + V _{REF}	RI - V _{REF} / 2	RI	RI + V _{REF} / 2

*RI = Reference Input (Table 2)

Single-Supply, Low-Power, 2-Channel, Serial 8-Bit ADCs

initiated. The MSB successive-approximation bit decision is made on the rising edge of the seventh SCLK. On the falling edge of the eighth SCLK, the MSB is clocked out on the DOUT pin; on each of the next seven SCLK falling edges, the remaining bits of conversion are clocked out. Zeros are clocked out on DOUT after the LSB has been clocked out, until \overline{CS} is disabled. Then DOUT becomes high impedance and the part is ready for another conversion (Figure 6).

The conversion must complete in 1ms, or droop on the sample-and-hold capacitors may degrade conversion results. Use internal clock mode if the serial-clock frequency is less than 50kHz, or if serial-clock interruptions could cause the conversion interval to exceed 1ms.

Internal Clock

Internal clock mode frees the μP from the burden of running the SAR conversion clock. This allows the conversion results to be read back at the processor's convenience, at any clock rate up to 2MHz.

An internal register stores data when the conversion is in progress. On the falling edge of the fourth SCLK, track mode is enabled, and on the falling edge of the eighth SCLK, acquisition is complete and internal conversion is initiated. The internal 400kHz clock completes the conversion in 20 μs typically (35 μs max), at which time the MSB of the conversion is present at the DOUT pin. The falling edge of SCLK clocks the remaining data out of this register at any time after the conversion is complete (Figure 8).

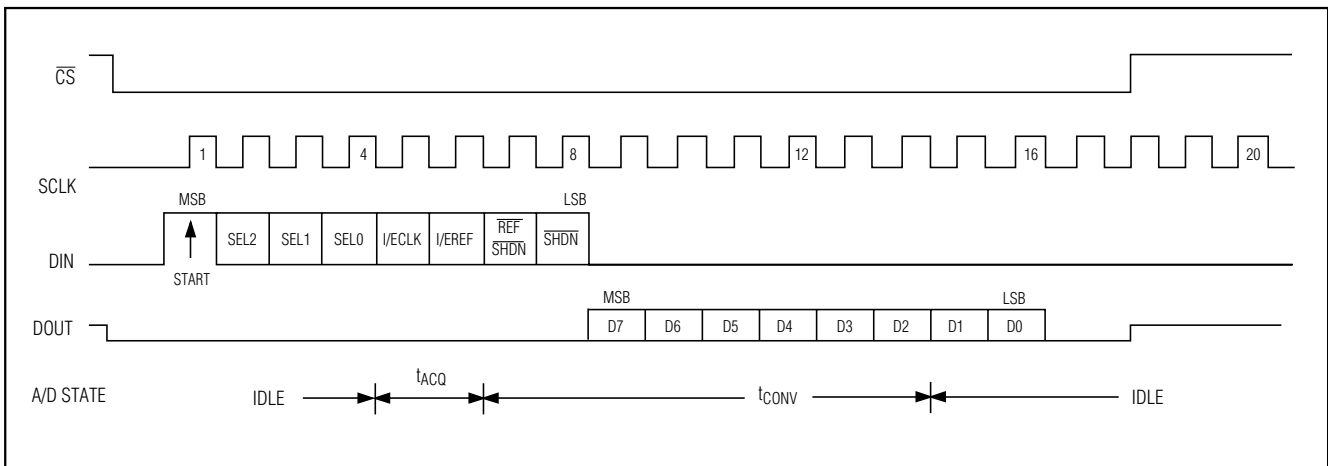

Figure 6. Single Conversion Timing, External Clock Mode

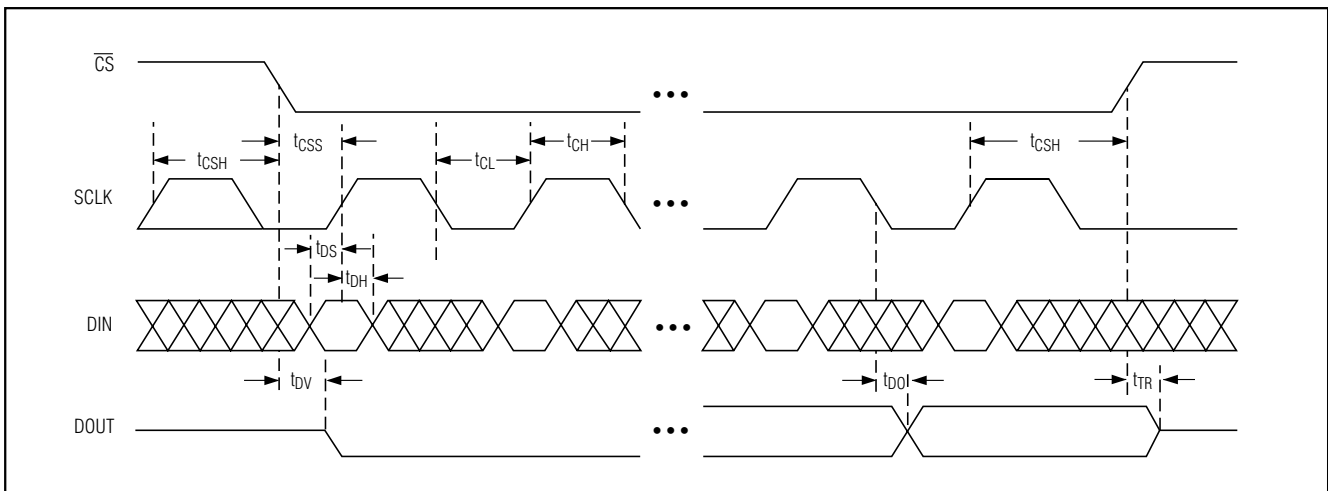

Figure 7. Detailed Serial-Interface Timing

Single-Supply, Low-Power, 2-Channel, Serial 8-Bit ADCs

\overline{CS} does not need to be held low once a conversion is started. Pulling \overline{CS} high prevents data from being clocked into the MAX1108/MAX1109 and three-states DOUT, but it does not adversely affect an internal clock-mode conversion already in progress. In this mode, data can be shifted in and out of the MAX1108/MAX1109 at clock rates up to 2MHz, provided that the minimum acquisition time (t_{ACQ}) is kept above 1 μ s.

Quick Look

To quickly evaluate the MAX1108/MAX1109's analog performance, use the circuit of Figure 9. The device requires a control byte to be written to DIN before each conversion. Tying \overline{CS} to GND and DIN to V_{DD} feeds in control bytes of FFH. In turn, this triggers single-ended, unipolar conversions on CH0 in relation to COM in external clock mode without powering down between conversions. Apply an external 50kHz clock

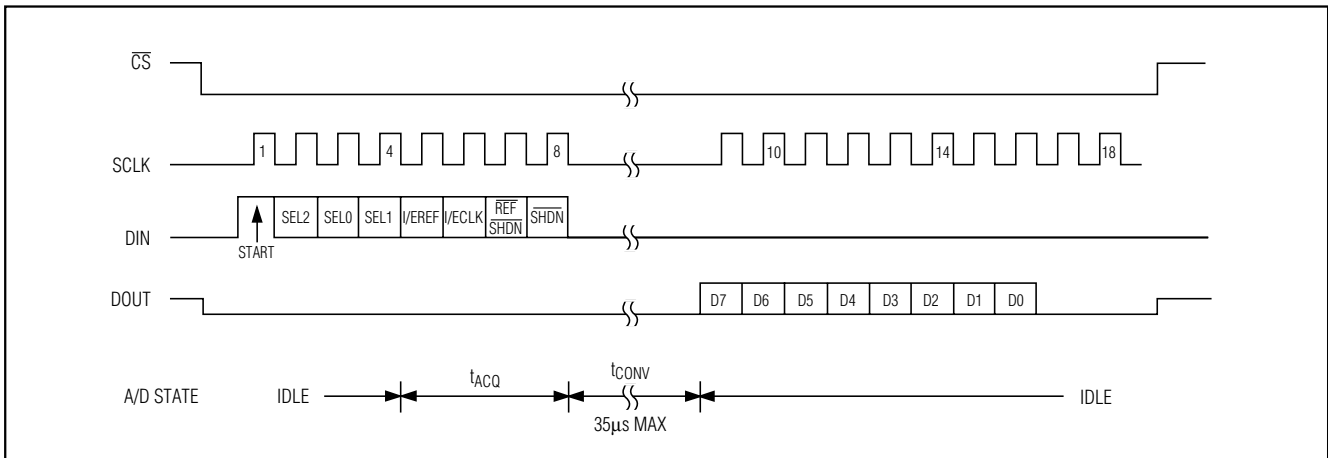

Figure 8. Single Conversion Timing, Internal Clock Mode

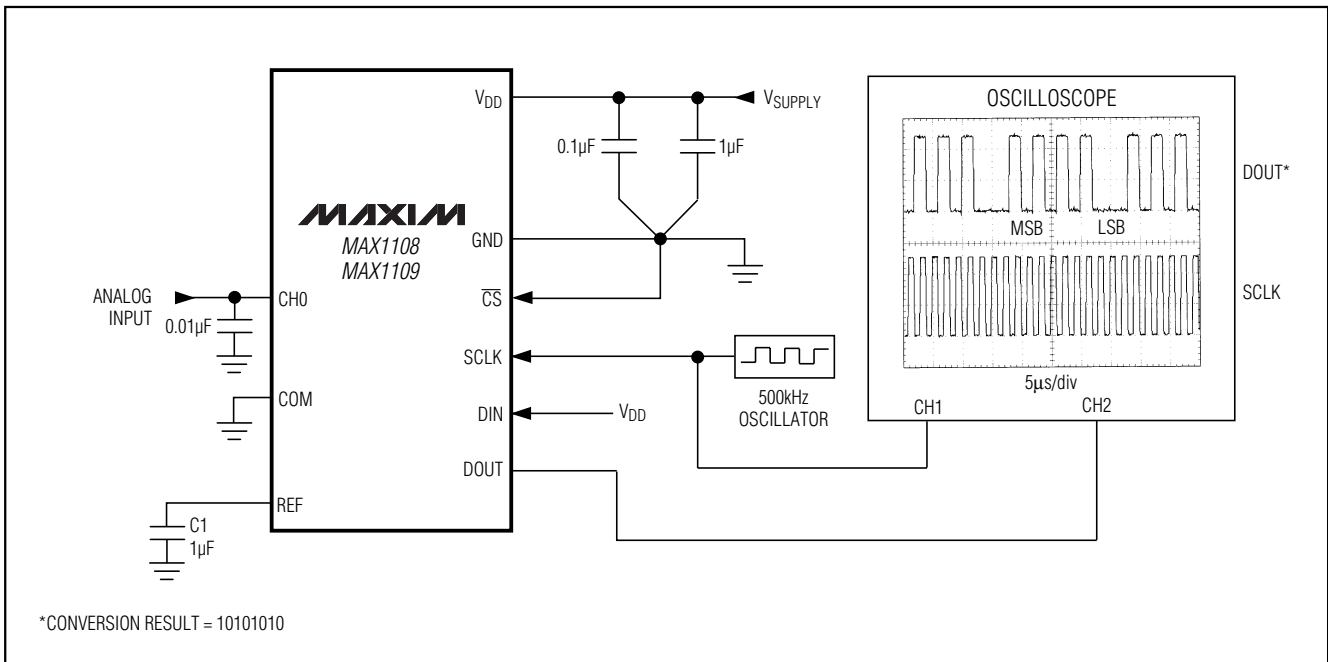

Figure 9. Quick-Look Schematic

Single-Supply, Low-Power, 2-Channel, Serial 8-Bit ADCs

to the SCLK pin; varying the analog input alters the result of conversion that is clocked out at the DOUT pin. A total of 10 clock cycles is required per conversion.

Data Framing

The falling edge of \overline{CS} does not start a conversion. The first logic high clocked into DIN is interpreted as a start bit and defines the first bit of the control byte. Acquisition starts on the falling edge of the fourth SCLK and lasts for two SCLKs in external clock mode or four SCLKs in internal clock mode. Conversion starts immediately after acquisition is completed. The start bit is defined as:

The first high bit clocked into DIN with \overline{CS} low any time the converter is idle; e.g., after V_{DD} is applied.

OR

In external clock mode, the first high bit clocked into DIN after the bit 5 (D5) of a conversion in progress is clocked onto the DOUT pin.

OR

In internal clock mode, the first high bit clocked into DIN after the bit 4 (D4) is clocked onto the DOUT pin.

The MAX1108/MAX1109 can run at a maximum speed of 10 clocks per conversion. Figure 10 shows the serial-interface timing necessary to perform a conversion every 10 SCLK cycles in external clock mode.

Many microcontrollers require that conversions occur in multiples of 8 SCLK clocks; 16 clocks per conversion is typically the fastest that a microcontroller can drive the MAX1108/MAX1109. Figure 11 shows the serial-interface timing necessary to perform a conversion every 16 SCLK cycles in external clock mode.

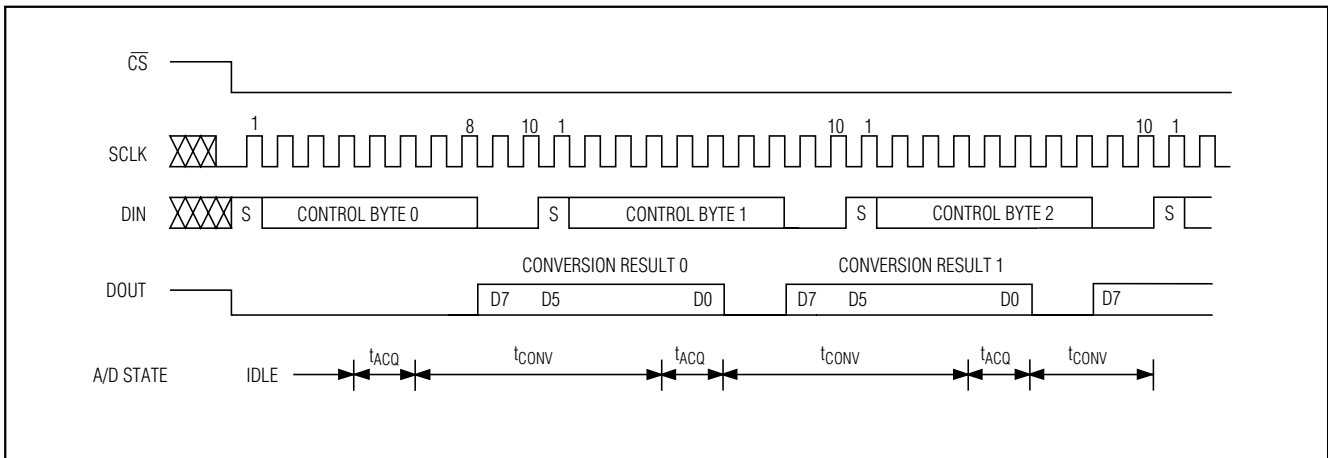

Figure 10. Continuous Conversion, External Clock Mode, 10 Clocks/Conversion Timing

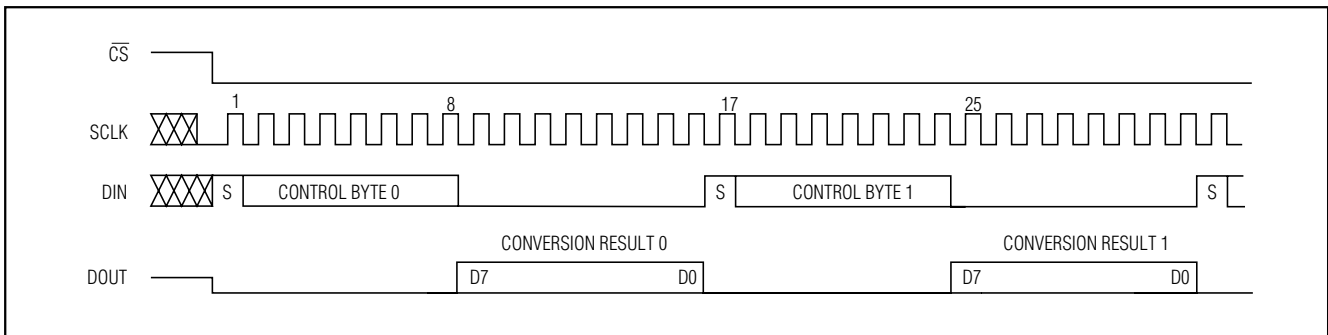

Figure 11. Continuous Conversion, External Clock Mode, 16 Clocks/Conversion Timing

Single-Supply, Low-Power, 2-Channel, Serial 8-Bit ADCs

In external clock mode, if \overline{CS} is toggled before the current conversion is complete, the current conversion is terminated, and the next high bit clocked into DIN is recognized as a new start bit. This can be useful in extending acquisition time by selecting conversion on the same channel with the second control byte (double-clocking mode), effectively extending acquisition to 6 SCLKs. This technique is ideal if the analog input source has high impedance, or if it requires more than 1 μ s to settle; it can also be used to allow the device and the reference to settle when using power down-modes (see *Power-Down Modes* section).

Applications Information

Battery Monitoring Mode

This mode of operation samples and converts the mid-supply voltage, $V_{DD} / 2$, which is internally generated. Set SEL2 = SEL1 = SEL0 = 0 in the control byte to select this configuration. This allows the user to monitor the condition of a battery providing V_{DD} . The reference voltage must be larger than $V_{DD} / 2$ for this mode of operation to work properly. From the result of conversion (CODE), V_{DD} is determined as follows: $V_{DD} = CODE \cdot V_{REF} / 128$.

Power-On Configuration

When power is first applied, the MAX1108/MAX1109's reference is powered down and \overline{SHDN} is not enabled. The device needs to be configured by setting \overline{CS} low and writing the control byte. Conversion can be started within 20 μ s if an external reference is used. When using the internal reference, allow 12ms for the reference to settle. This is done by first performing a configuration conversion to power up the reference and then performing a second conversion once the reference is settled. No conversions should be considered correct until the reference voltage (internal or external) has stabilized.

Power-Down Modes

To save power, place the converter into low-current power-down mode between conversions. Minimum power consumption is achieved by programming $\overline{REFSHDN} = 0$ and $\overline{SHDN} = 0$ in the input control byte (Table 4). When software power-down is asserted, it becomes effective only after the conversion. If the control byte contains $\overline{REFSHDN} = 0$, then the reference will turn off at the end of conversion. If $\overline{SHDN} = 0$, then the chip will power-down at the end of conversion (in this mode I/REF or $\overline{REFSHDN}$ should also be set to zero). Table 4 lists the power-down modes of the MAX1108/MAX1109.

Table 4. Power-Down Modes of the MAX1108/MAX1109

BIT 2–BIT 0 OF CONTROL BYTE			OPERATING MODE
I/REF	$\overline{REFSHDN}$	\overline{SHDN}	
1	1	1	Device Active/Internal Reference Active
1	0	1	Device Active; Internal reference powered down after conversion, powered up at next start bit.
0	X	1	Device Active/External Reference Mode
1	0	0	Device and internal reference powered down after conversion, powered up at next start bit.
0	X	0	Device powered down after each conversion, powered up at next start bit. External Reference Mode.
1	1	0	Reserved. Do not use.

X = Don't care

The first logical 1 clocked into DIN after \overline{CS} falls powers up the MAX1108/MAX1109 (20 μ s required for the device to power up). The reference is powered up only if internal reference was selected during the previous conversion. When the reference is powered up after being disabled, consider the settling time before using the result of conversion. Typically, 12ms are required for the reference to settle from a discharge state; less time may be considered if the external capacitor is not discharged completely when exiting shutdown. In all power-down modes, the interface remains active and conversion results may be read. Use the double clocking technique described in the *Data Framing* section to allow more time for the reference to settle before starting a conversion after short power-down.

Voltage Reference

The MAX1108/MAX1109 operate from a single supply and feature a software-controlled internal reference of +2.048V (MAX1108) and +4.096V (MAX1109). The device can operate with either the internal reference or an external reference applied at the REF pin. See the *Power-Down Modes* and *Modes of Operation* sections for detailed instructions on reference configuration.

The reference voltage determines the full-scale range: in unipolar mode, the input range is from 0 to V_{REF} ; in bipolar mode, the input range spans $R_I \pm V_{REF} / 2$ with $R_I = V_{REF} / 2$.

Single-Supply, Low-Power, 2-Channel, Serial 8-Bit ADCs

External Reference

To use an external reference, set bit 2 (I/EREF) and bit 1 (REFSHDN) of control byte to 0 and connect the external reference (V_{REF} between 1V and V_{DD}) directly at the REF pin. The DC input impedance at REF is extremely high, consisting of leakage current only (typically 10nA). During a conversion, the reference must be able to deliver up to 20 μ A average load current and have an output impedance of 1k Ω or less at the conversion clock frequency. If the reference has higher output impedance or is noisy, bypass it close to the REF pin with a 0.1 μ F capacitor. MAX1109 has an internal reference of +4.096V. To use the device with supply voltages below 4.5V, external reference mode is required.

With an external reference voltage of less than +2.048V (MAX1108) or +4.096V (MAX1109) at REF, the increase in the ratio of the RMS noise to the LSB value ($FS / 256$) results in performance degradation and decreased dynamic range.

Internal Reference

To use the internal reference, set bit 2 (I/EREF) and bit 1 (REFSHDN) of the control byte to 1 and bypass REF with a 1 μ F capacitor to ground. The internal reference can be powered down after a conversion by setting bit 1 (REFSHDN) of the control byte to 0. When using the internal reference, use MAX1108 and MAX1109 with supply voltage below 4.5V and above 4.5V, respectively.

Transfer Function

Table 4 shows the full-scale voltage ranges for unipolar and bipolar modes. Figure 12a depicts the nominal, unipolar I/O transfer function, and Figure 12b shows the bipolar I/O transfer function. The zero scale is determined by the input selection setting and is either COM, GND, or CH1.

Code transitions occur at integer LSB values. Output coding is straight binary for unipolar operation and two's complement for bipolar operation. With a +2.048V reference, $1\text{LSB} = 8\text{mV}$ ($V_{REF} / 256$).

Layout, Grounding, and Bypassing

For best performance, use printed circuit boards. Wire-wrap boards are not recommended. Board layout should ensure that digital and analog signal lines are separated from each other. Do not run analog and digital (especially clock) lines parallel to one another or run digital lines underneath the ADC package.

Figure 13 shows the recommended system-ground connections. A single-point analog ground (star-ground point) should be established at the A/D ground. Connect all analog grounds to the star ground. No digital-system ground should be connected to this point.

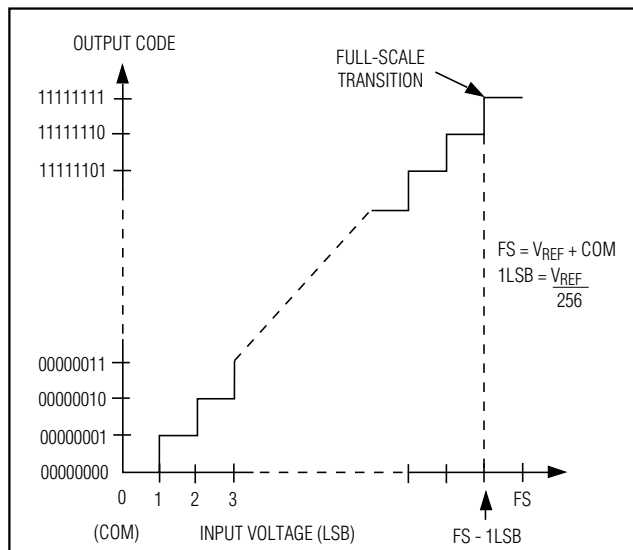

Figure 12a. Unipolar Transfer Function

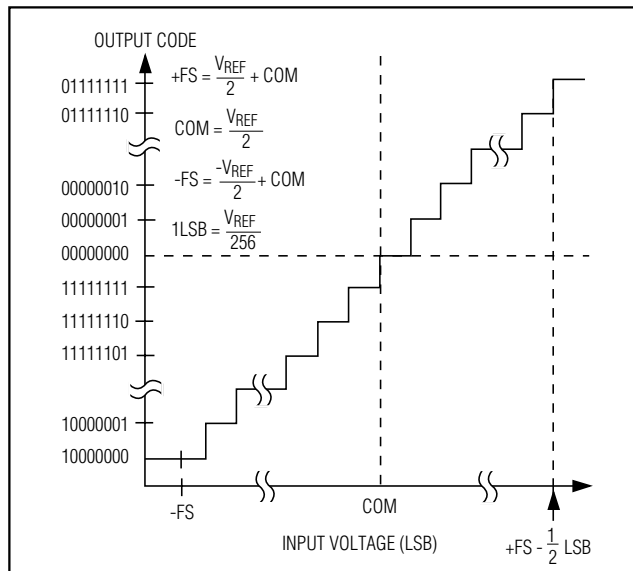

Figure 12b. Bipolar Transfer Function

The ground return to the power supply for the star ground should be low impedance and as short as possible for noise-free operation.

High-frequency noise in the V_{DD} power supply may affect the comparator in the ADC. Bypass the supply to the star ground with 0.1 μ F and 1 μ F capacitors close to the V_{DD} pin of the MAX1108/MAX1109. Minimize capacitor lead lengths for best supply-noise rejection. If the power supply is very noisy, a 10 Ω resistor can be connected to form a lowpass filter.

Single-Supply, Low-Power, 2-Channel, Serial 8-Bit ADCs

Chip Information

TRANSISTOR COUNT: 2373

MAX1108/MAX1109

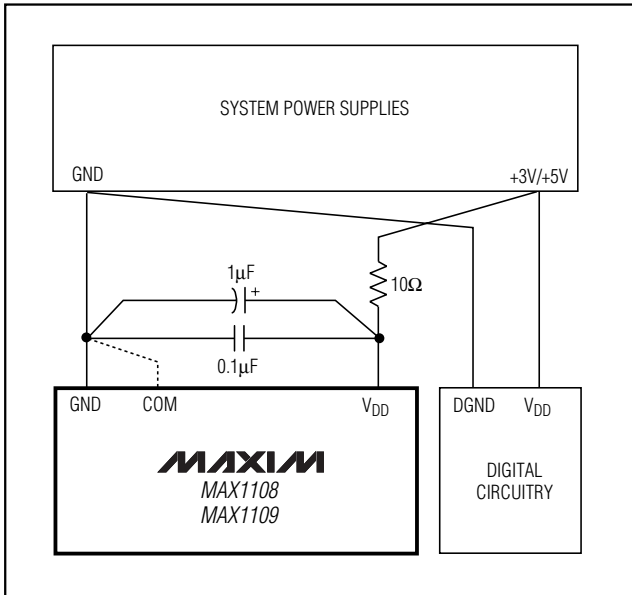
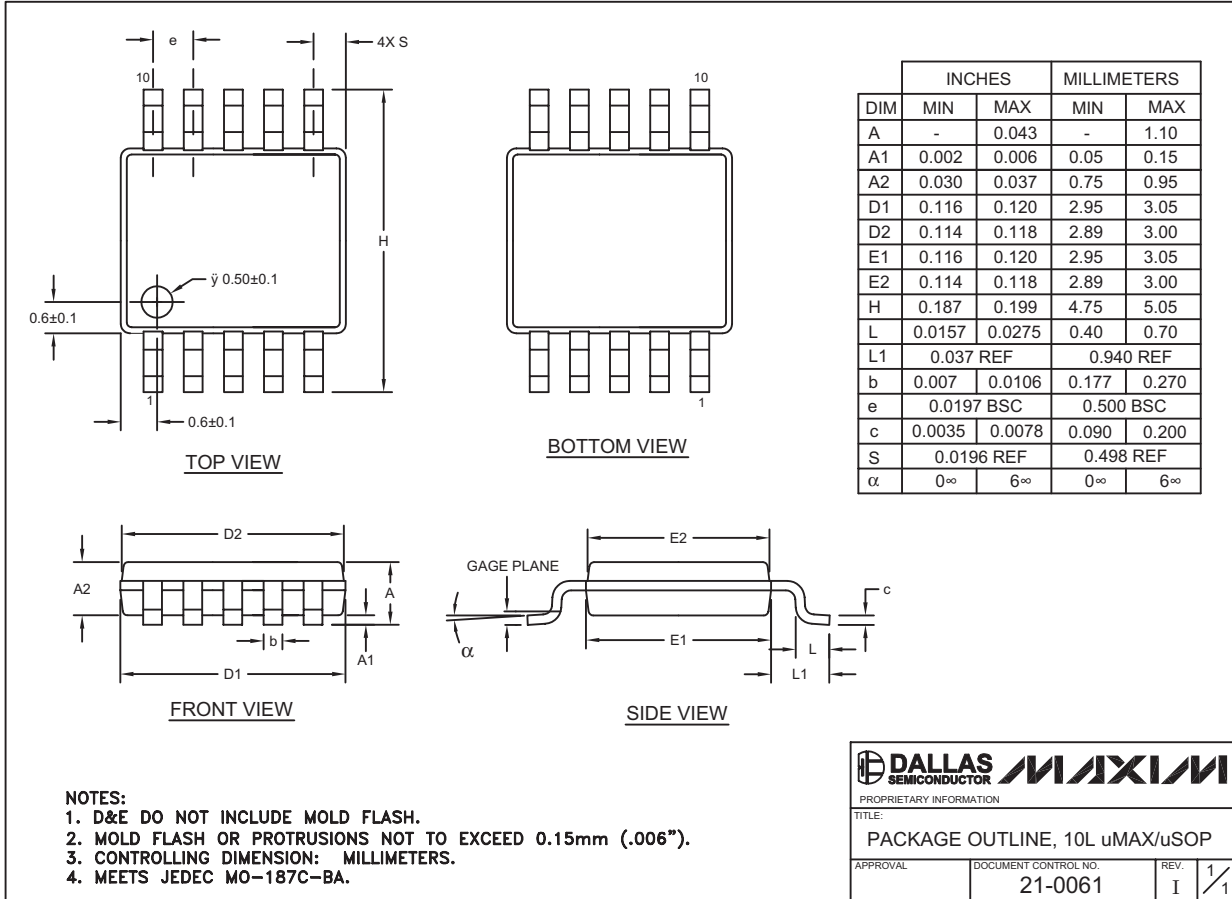

Figure 13. Power-Supply Connections

Single-Supply, Low-Power, 2-Channel, Serial 8-Bit ADCs

Package Information

(The package drawing(s) in this data sheet may not reflect the most current specifications. For the latest package outline information, go to www.maxim-ic.com/packages.



10L uMAX/EPs

Maxim cannot assume responsibility for use of any circuitry other than circuitry entirely embodied in a Maxim product. No circuit patent licenses are implied. Maxim reserves the right to change the circuitry and specifications without notice at any time.

20 **Maxim Integrated Products, 120 San Gabriel Drive, Sunnyvale, CA 94086 408-737-7600**