



Chipsmall Limited consists of a professional team with an average of over 10 year of expertise in the distribution of electronic components. Based in Hongkong, we have already established firm and mutual-benefit business relationships with customers from,Europe,America and south Asia,supplying obsolete and hard-to-find components to meet their specific needs.

With the principle of “Quality Parts,Customers Priority,Honest Operation,and Considerate Service”,our business mainly focus on the distribution of electronic components. Line cards we deal with include Microchip,ALPS,ROHM,Xilinx,Pulse,ON,Everlight and Freescale. Main products comprise IC,Modules,Potentiometer,IC Socket,Relay,Connector.Our parts cover such applications as commercial,industrial, and automotives areas.

We are looking forward to setting up business relationship with you and hope to provide you with the best service and solution. Let us make a better world for our industry!



Contact us

Tel: +86-755-8981 8866 Fax: +86-755-8427 6832

Email & Skype: info@chipsmall.com Web: www.chipsmall.com

Address: A1208, Overseas Decoration Building, #122 Zhenhua RD., Futian, Shenzhen, China



MAX11158

18-Bit, 500ksps, $\pm 5V$ SAR ADC with Internal Reference in μ MAX

General Description

The MAX11158 is an 18-bit, 500ksps, SAR ADC offering excellent AC and DC performance with true bipolar input range, internal reference, and small size. The MAX11158 measures a $\pm 5V$ ($10V_{P-P}$) input range while operating from a single 5V supply. A patented charge-pump architecture allows direct sampling of high-impedance sources. The MAX11158 integrates a low drift reference with internal buffer, saving the cost and space of an external reference.

This ADC achieves 93.7dB SNR and -100.0dB THD. The MAX11158 guarantees 18-bit no-missing codes and ± 2.7 LSB INL (typ).

The MAX11158 communicates using an SPI-compatible serial interface at 2.5V, 3V, 3.3V, or 5V logic. The serial interface can be used to daisy-chain multiple ADCs for multichannel applications and provides a busy indicator option for simplified system synchronization and timing.

The MAX11158 is offered in a 10-pin, 3mm x 5mm, μ MAX[®] package and is specified over the $-40^{\circ}C$ to $+85^{\circ}C$ temperature range.

Applications

- Industrial Process Control
- Data Acquisition Systems
- Medical Instrumentation
- Automatic Test Equipment

Typical Operating Circuit

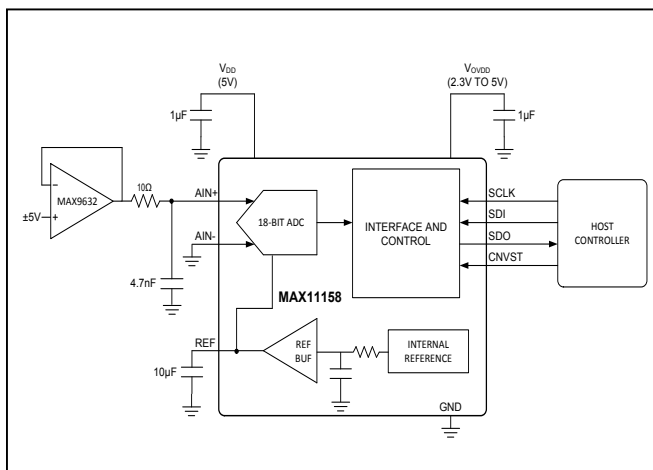

Benefits and Features

- High DC/AC Accuracy Improves Measurement Quality
 - 18-Bit Resolution with No Missing Codes
 - 500ksps Throughput Rates Without Pipeline Delay/Latency
 - 93.7dB SNR and -100.0dB THD at 10kHz
 - 2.0 LSB_{RMS} Transition Noise
 - ± 0.5 LSB DNL (typ) and ± 2.7 LSB INL (typ)
- Highly Integrated ADC Saves Cost and Space
 - ± 7 ppm/ $^{\circ}C$ Internal Reference
 - Internal Reference Buffer
- Wide Supply Range and Low Power Simplify Power-Supply Design
 - 5V Analog Supply
 - 2.3V to 5V Digital Supply
 - 38mW Power Consumption at 500ksps
 - 10 μ A in Shutdown Mode
- Multi-Industry Standard Serial Interface and Small Package Reduces Size
 - SPI/QSPI[™]/MICROWIRE[®]/DSP-Compatible Serial Interface
 - 3mm x 5mm Tiny 10-Pin μ MAX Package

μ MAX is a registered trademark of Maxim Integrated Products, Inc.

QSPI is a trademark of Motorola, Inc.

MICROWIRE is a registered trademark of National Semiconductor Corporation.

[Selector Guide](#) and [Ordering Information](#) appear at end of data sheet.

14-Bit to 18-Bit SAR ADC Family

	14-BIT 500ksps	16-BIT 250ksps	16-BIT 500ksps	18-BIT 500ksps
$\pm 5V$ Input Internal Reference	—	MAX11167 MAX11169	MAX11166 MAX11168	MAX11156 MAX11158
0 to 5V Input Internal Reference	—	MAX11161 MAX11165	MAX11160 MAX11164	MAX11150 MAX11154
0 to 5V Input External Reference	MAX11262	MAX11163	MAX11162	MAX11152

Absolute Maximum Ratings

V_{DD} to GND.....-0.3V to +6V
 OVDD to GND..... -0.3V to the lower of (V_{DD} + 0.3V) and +6V
 AIN+ to GND..... ±7V
 AIN-, REF,to GND.....-0.3V to the lower of (V_{DD} + 0.3V) and +6V
 SCLK, SDI, SDO, CNVST to GND..... -0.3V to the lower of (V_{DD} + 0.3V) and +6V
 Maximum Current into Any Pin.....50mA

Continuous Power Dissipation (T_A = +70°C)
 μMAX (derate 8.8mW/°C above +70°C).....707mW
 Operating Temperature Range.....-40°C to +85°C
 Junction Temperature.....+150°C
 Storage Temperature Range..... -65°C to +150°C
 Lead Temperature (soldering, 10s).....+300°C
 Soldering Temperature (reflow).....+260°C

Stresses beyond those listed under "Absolute Maximum Ratings" may cause permanent damage to the device. These are stress ratings only, and functional operation of the device at these or any other conditions beyond those indicated in the operational sections of the specifications is not implied. Exposure to absolute maximum rating conditions for extended periods may affect device reliability.

Package Thermal Characteristics (Note 1)

μMAX
 Junction-to-Ambient Thermal Resistance (θ_{JA}).....113°C/W
 Junction-to-Case Thermal Resistance (θ_{JC}).....36°C/W

Note 1: Package thermal resistances were obtained using the method described in JEDEC specification JESD51-7, using a four-layer board. For detailed information on package thermal considerations, refer to www.maximintegrated.com/thermal-tutorial.

Electrical Characteristics

(V_{DD} = 4.75V to 5.25V, V_{OVDD} = 2.3V to 5.25V, f_{SAMPLE} = 500kps, T_A = T_{MIN} to T_{MAX}, unless otherwise noted. Typical values are at T_A = +25°C.) (Note 2)

PARAMETER	SYMBOL	CONDITIONS	MIN	TYP	MAX	UNITS
ANALOG INPUT (Note 3)						
Input Voltage Range		AIN+ to AIN-, k = 5/4.096	-V _{REF} x k		+V _{REF} x k	V
Absolute Input Voltage Range		AIN+ to GND	-5.1		+5.1	V
		AIN- to GND	-0.1		+0.1	
Input Leakage Current		Acquisition phase	-10	+0.001	+10	μA
Input Capacitance				40		pF
Input-Clamp Protection Current		Both inputs	-20		+20	mA
STATIC PERFORMANCE (Note 4)						
Resolution	N		18			Bits
No Missing Codes			18			Bits
Offset Error		V _{OVDD} ≤ 3.6V	-18	±4	+18	LSB
		V _{OVDD} > 3.6V	-32		+32	
Offset Temperature Coefficient				±0.08		LSB/°C
Gain Error		V _{OVDD} ≤ 3.6V	-24		+24	LSB
		V _{OVDD} > 3.6V	-30		+30	
Gain Error Temperature Coefficient				±0.04		LSB/°C
Integral Nonlinearity	INL	V _{OVDD} ≤ 3.6V	-6	±2.7	+6	LSB
		V _{OVDD} > 3.6V	-9		+9	
Differential Nonlinearity	DNL	Guaranteed by design	-1.0	±0.5	+1	LSB
Positive Full-Scale Error		V _{OVDD} ≤ 3.6V	-22		+22	LSB
		V _{OVDD} > 3.6V	-33		+33	

Electrical Characteristics (continued)

($V_{DD} = 4.75V$ to $5.25V$, $V_{OVDD} = 2.3V$ to $5.25V$, $f_{SAMPLE} = 500ksps$, $T_A = T_{MIN}$ to T_{MAX} , unless otherwise noted. Typical values are at $T_A = +25^\circ C$.) (Note 2)

PARAMETER	SYMBOL	CONDITIONS	MIN	TYP	MAX	UNITS
Negative Full-Scale Error		$V_{OVDD} \leq 3.6V$	-28		+28	LSB
		$V_{OVDD} > 3.6V$	-41		+41	
Analog Input CMR	CMR	Referred to the output		-5.3		LSB/V
Power-Supply Rejection (Note 5)	PSR	PSR vs. V_{DD} , referred to the output		-20		LSB/V
Transition Noise				2.0		LSB _{RMS}
REFERENCE						
REF Initial Accuracy	V_{REF}		4.092	4.096	4.100	V
REF Temperature Coefficient	TC_{REF}		-17	± 7	+17	ppm/ $^\circ C$
REF Output Impedance	Z_{REF}			0.1		Ω
DYNAMIC PERFORMANCE (Note 6)						
Signal-to-Noise Ratio	SNR	$f_{IN} = 10kHz$	91.7	93.7		dB
Signal-to-Noise Plus Distortion	SINAD	$f_{IN} = 10kHz$	90.7	92.8		dB
Spurious-Free Dynamic Range	SFDR	$V_{OVDD} \leq 3.6V$	99	101.8		dB
		$V_{OVDD} > 3.6V$	96			
Total Harmonic Distortion	THD	$V_{OVDD} \leq 3.6V$		-100.0	-97.6	dB
		$V_{OVDD} > 3.6V$			-95.5	
Intermodulation Distortion (Note 7)	IMD			-115		dBFS
SAMPLING DYNAMICS						
Throughput Sample Rate			0.01		500	ksps
Transient Response		Full-scale step			400	ns
Full-Power Bandwidth		-3dB point		6		MHz
		-0.1dB point		> 0.2		
Aperture Delay				2.5		ns
Aperture Jitter				50		ps _{RMS}
POWER SUPPLIES						
Analog Supply Voltage	V_{DD}		4.75		5.25	V
Interface Supply Voltage	V_{OVDD}		2.3		5.25	V
Analog Supply Current	I_{VDD}		5.0	6.0	7.0	mA
V_{DD} Shutdown Current				6.2	10	μA
Interface Supply Current		$V_{OVDD} = 2.3V$		1.6	2.0	mA
		$V_{OVDD} = 5.25V$		4.3	5	
OVDD Shutdown Current				0.8	10	μA
Power Dissipation		$V_{DD} = 5V$, $V_{OVDD} = 3.3V$		38.1		mW

Electrical Characteristics (continued)

($V_{DD} = 4.75V$ to $5.25V$, $V_{OVDD} = 2.3V$ to $5.25V$, $f_{SAMPLE} = 500kps$, $T_A = T_{MIN}$ to T_{MAX} , unless otherwise noted. Typical values are at $T_A = +25^{\circ}C$.) (Note 2)

PARAMETER	SYMBOL	CONDITIONS	MIN	TYP	MAX	UNITS
DIGITAL INPUTS (SDI, SCLK, CNVST)						
Input Voltage High	V_{IH}		$0.7 \times V_{OVDD}$			V
Input Voltage Low	V_{IL}				$0.3 \times V_{OVDD}$	V
Input Hysteresis	V_{HYS}			$\pm 0.05 \times V_{OVDD}$		V
Input Capacitance	C_{IN}			10		pF
Input Current	I_{IN}	$V_{IN} = 0V$ or V_{OVDD}	-10		+10	μA
DIGITAL OUTPUT (SDO)						
Output Voltage High	V_{OH}	$I_{SOURCE} = 2mA$	$V_{OVDD} - 0.4$			V
Output Voltage Low	V_{OL}	$I_{SINK} = 2mA$			0.4	V
Three-State Leakage Current			-10		+10	μA
Three-State Output Capacitance				15		pF
TIMING (Note 8)						
Time Between Conversions	t_{CYC}		2			μs
Conversion Time	t_{CONV}	CNVST rising to data available	1.3		1.5	μs
Acquisition Time	t_{ACQ}	$t_{ACQ} = t_{CYC} - t_{CONV}$	0.5			μs
CNVST Pulse Width	t_{CNVPW}	\overline{CS} mode	5			ns
SCLK Period (\overline{CS} Mode)	t_{SCLK}	$V_{OVDD} > 4.5V$	14			ns
		$V_{OVDD} > 2.7V$	20			
		$V_{OVDD} > 2.3V$	25			
SCLK Period (Daisy-Chain Mode)	t_{SCLK}	$V_{OVDD} > 4.5V$	16			ns
		$V_{OVDD} > 2.7V$	24			
		$V_{OVDD} > 2.3V$	30			
SCLK Low Time	t_{SCLKL}		6			ns
SCLK High Time	t_{SCLKH}		6			ns
SCLK Falling Edge to Data Valid Delay	t_{DSDO}	$V_{OVDD} > 4.5V$			12	ns
		$V_{OVDD} > 2.7V$			18	
		$V_{OVDD} > 2.3V$			23	

Electrical Characteristics (continued)

($V_{DD} = 4.75V$ to $5.25V$, $V_{OVDD} = 2.3V$ to $5.25V$, $f_{SAMPLE} = 500kps$, $T_A = T_{MIN}$ to T_{MAX} , unless otherwise noted. Typical values are at $T_A = +25^\circ C$.) (Note 2)

PARAMETER	SYMBOL	CONDITIONS	MIN	TYP	MAX	UNITS
CNVST Low to SDO D15 MSB Valid (CS Mode)	t_{EN}	$V_{OVDD} > 2.7V$			14	ns
		$V_{OVDD} < 2.7V$			18	
CNVST High or SDI High or Last SCLK Falling Edge to SDO High Impedance	t_{DIS}	\overline{CS} mode			20	ns
SDI Valid Setup Time from CNVST Rising Edge	$t_{SSDICNV}$	4-wire \overline{CS} mode	5			ns
SDI Valid Hold Time from CNVST Rising Edge	$t_{HSDICNV}$	4-wire \overline{CS} mode	0			ns
SCLK Valid Setup Time from CNVST Rising Edge	$t_{SSCKCNV}$	Daisy-chain mode	3			ns
SCLK Valid Hold Time from CNVST Rising Edge	$t_{HSCKCNV}$	Daisy-chain mode	3			ns
SDI Valid Setup Time from SCLK Falling Edge	$t_{SSDISCK}$	Daisy-chain mode, $V_{OVDD} > 4.5V$	3			ns
		Daisy-chain mode, $V_{OVDD} > 2.7V$	5			
		Daisy-chain mode, $V_{OVDD} > 2.3V$	6			
SDI Valid Hold Time from SCLK Falling Edge	$t_{HSDISCK}$	Daisy-chain mode	0			ns
SDI High to SDO High	$t_{DSDOSDI}$	Daisy-chain mode with busy indicator, $V_{OVDD} > 4.5V$			10	ns
		Daisy-chain mode with busy indicator, $V_{OVDD} > 2.7V$			15	
		Daisy-chain mode with busy indicator, $V_{OVDD} > 2.3V$			20	

Note 2: Maximum and minimum limits are fully production tested over specified supply voltage range and at a temperature of $+25^\circ C$. Limits over the operating temperature range are guaranteed by design and device characterization.

Note 3: See the [Analog Inputs](#) and [Overvoltage Input Clamps](#) sections.

Note 4: Static Performance limits are guaranteed by design and device characterization.

Note 5: Defined as the change in positive full-scale code transition caused by a $\pm 5\%$ variation in the V_{DD} supply voltage.

Note 6: 10kHz sine wave input, $-0.1dB$ below full scale.

Note 7: $f_{IN1} \sim 9.4kHz$, $f_{IN2} \sim 10.7kHz$, Each tone at $6.1dB$ below full scale.

Note 8: $C_{LOAD} = 65pF$ on SDO.

Typical Operating Characteristics

($V_{DD} = 5.0V$, $V_{OVDD} = 3.3V$, $f_{SAMPLE} = 500kps$; $T_A = +25^\circ C$, unless otherwise noted.)

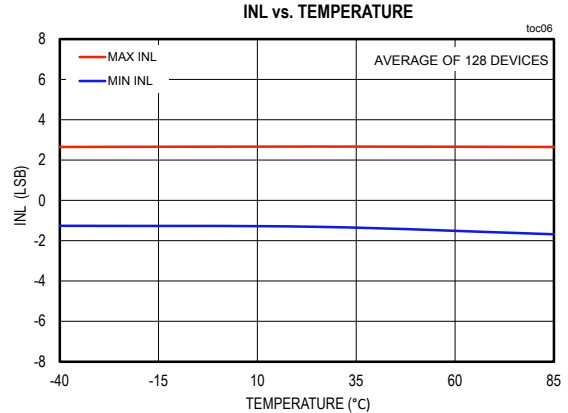
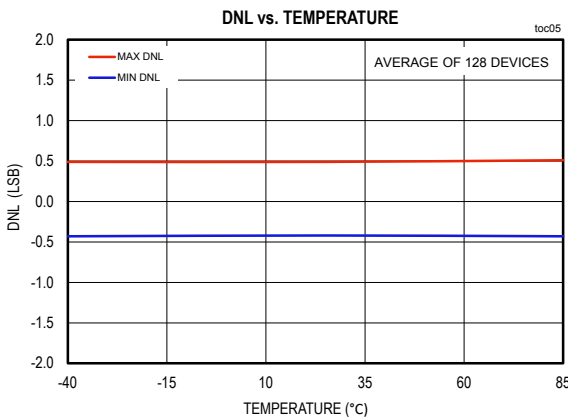
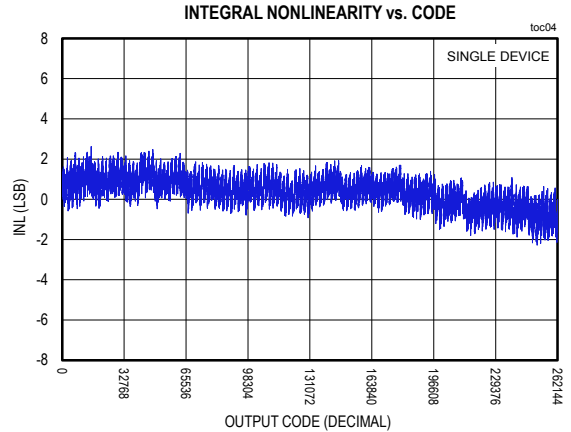
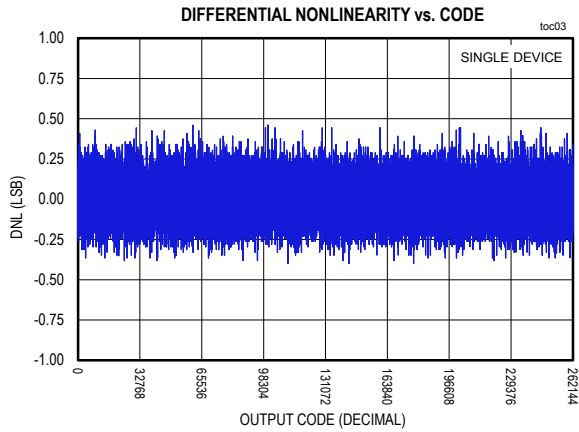
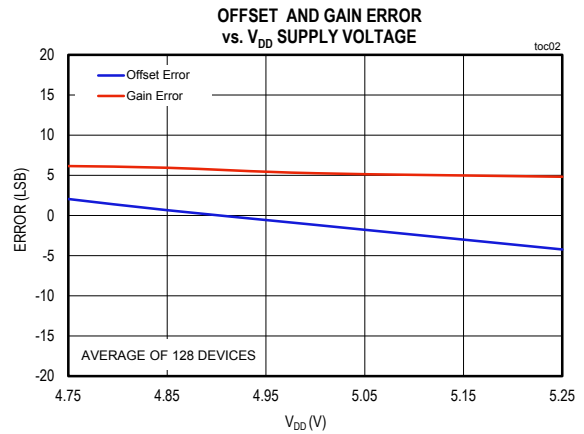
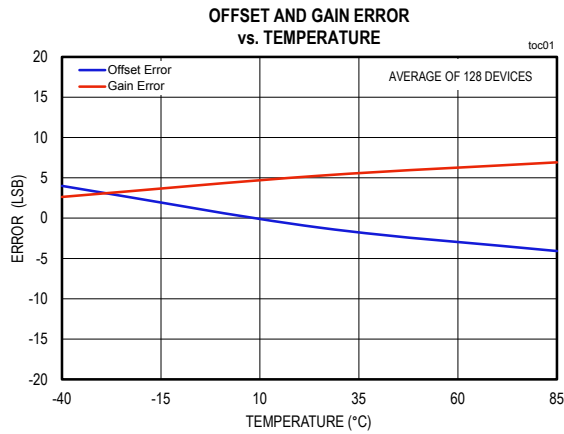

Typical Operating Characteristics (continued)

($V_{DD} = 5.0V$, $V_{OVDD} = 3.3V$, $f_{SAMPLE} = 500kps$, $T_A = +25^\circ C$, unless otherwise noted.)

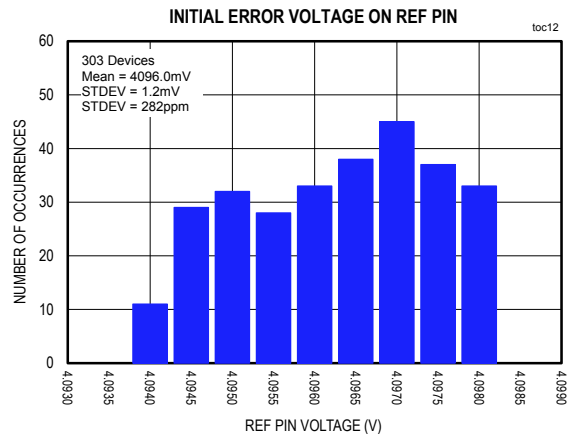
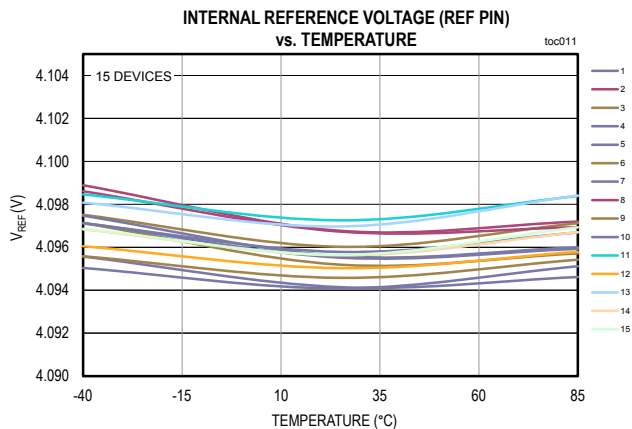
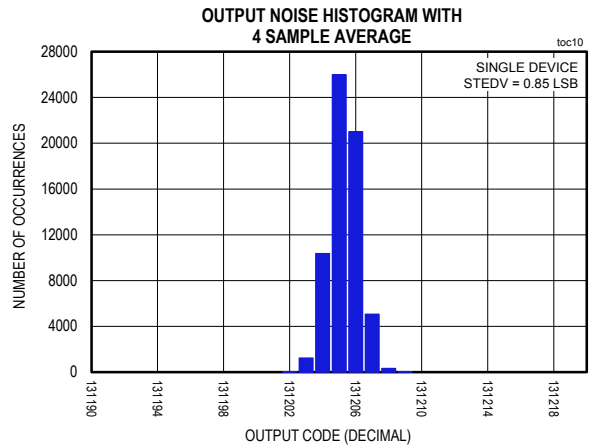
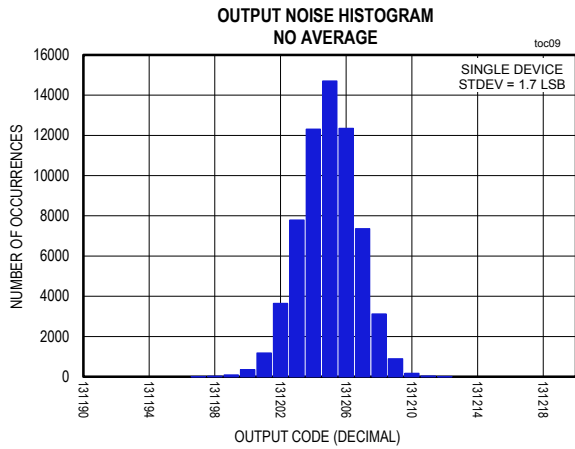
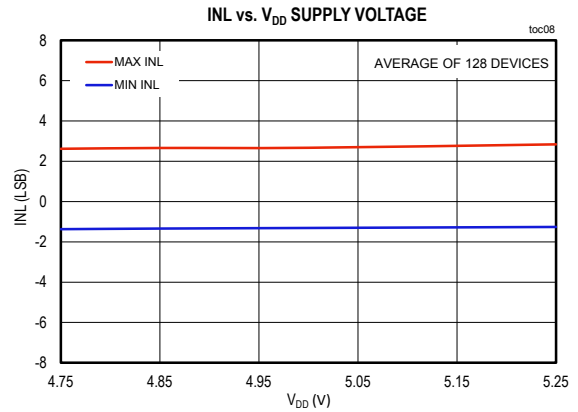
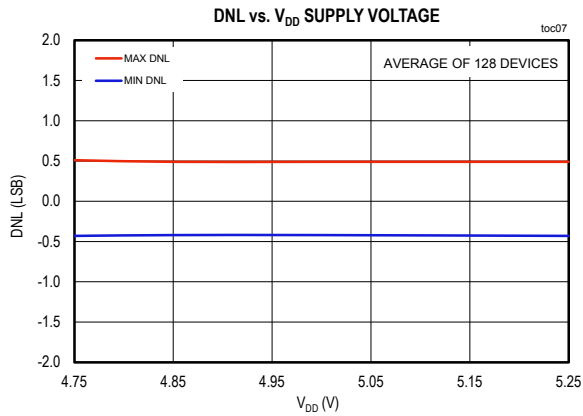

Typical Operating Characteristics (continued)

(V_{DD} = 5.0V, V_{OVDD} = 3.3V, f_{SAMPLE} = 500ksps, T_A = +25°C, unless otherwise noted.)

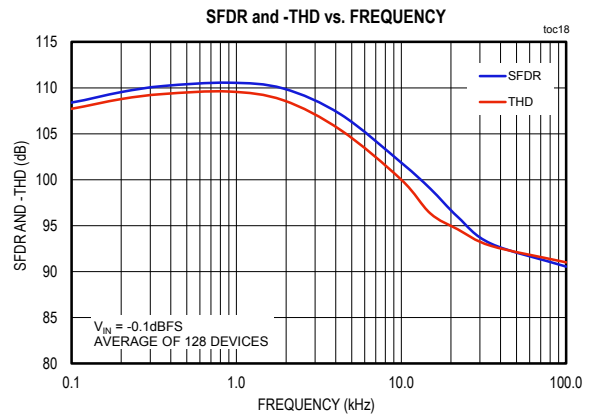
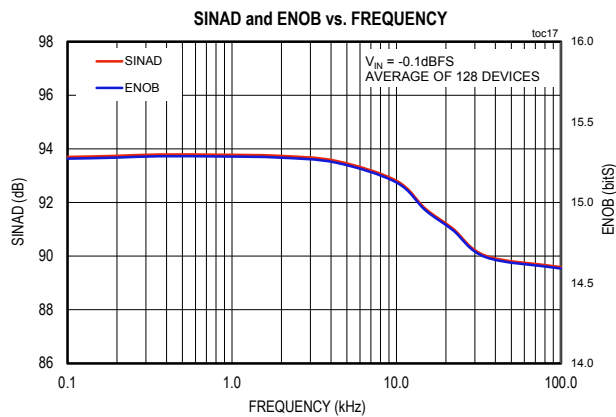
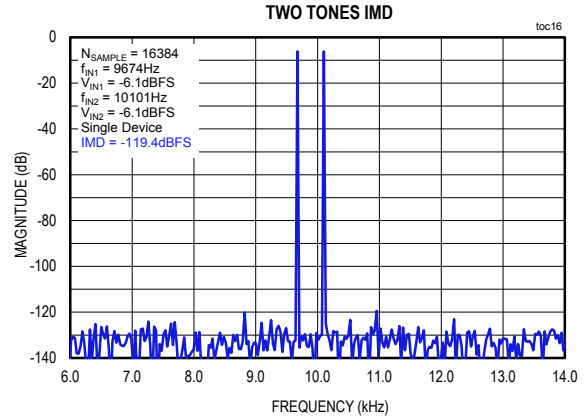
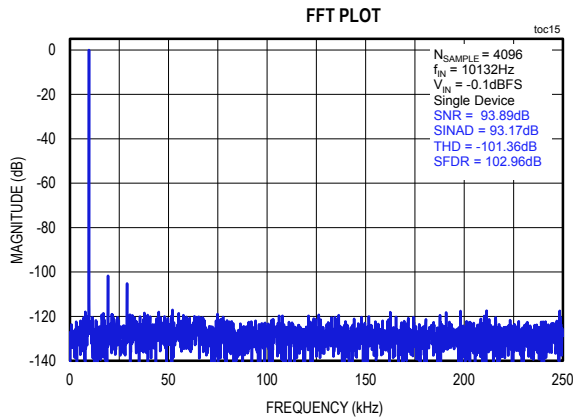
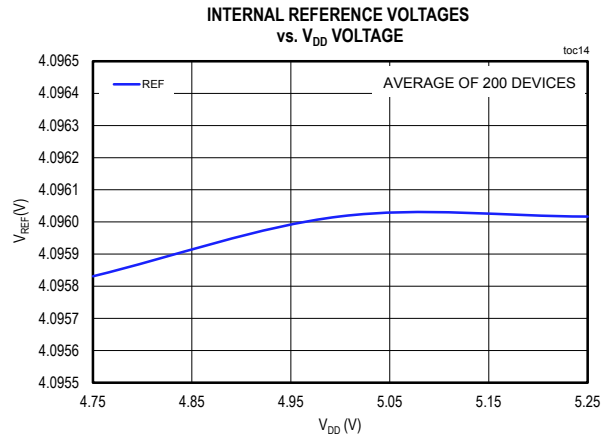
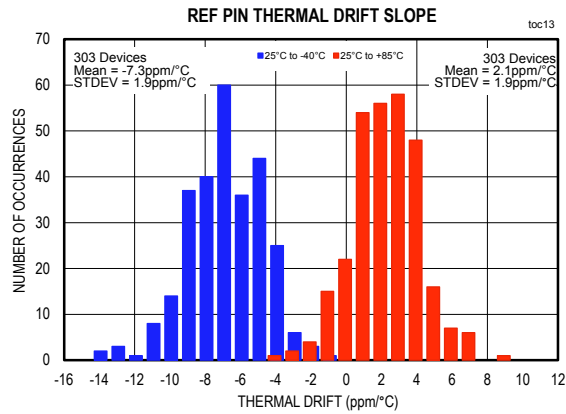

Typical Operating Characteristics (continued)

($V_{DD} = 5.0V$, $V_{OVDD} = 3.3V$, $f_{SAMPLE} = 500ksps$, $T_A = +25^{\circ}C$, unless otherwise noted.)

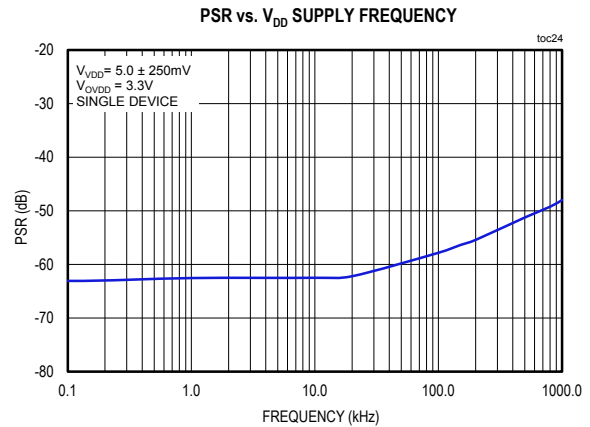
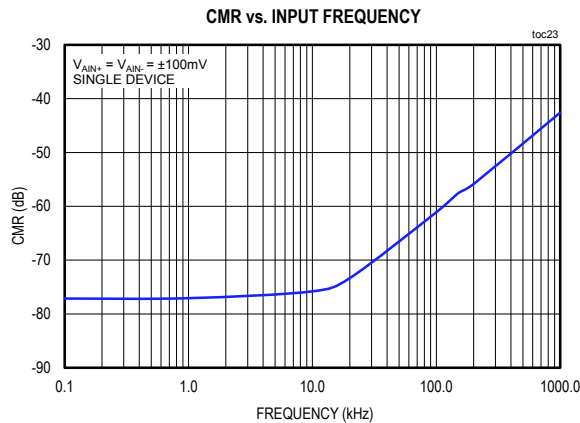
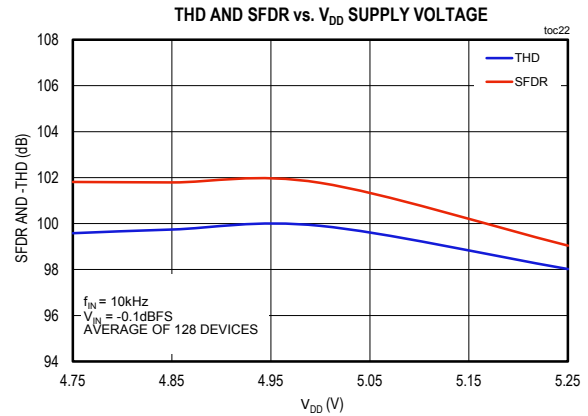
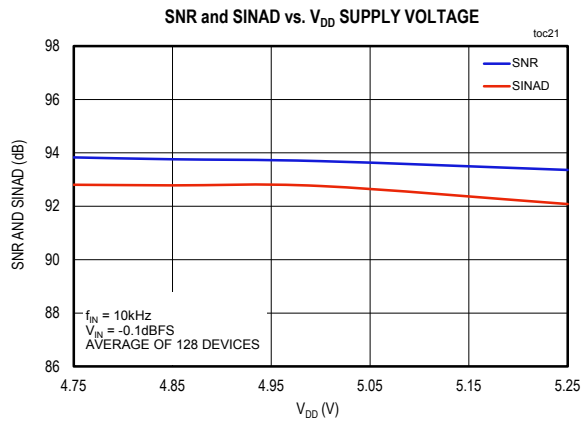
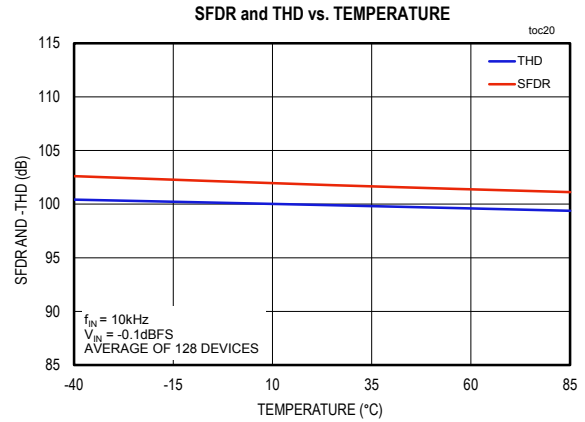
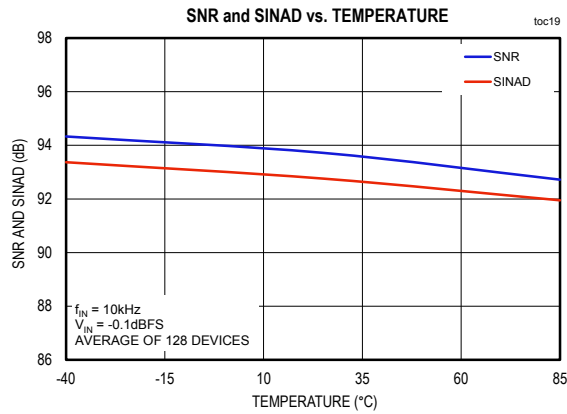

Typical Operating Characteristics (continued)

($V_{DD} = 5.0V$, $V_{OVDD} = 3.3V$, $f_{SAMPLE} = 500ksps$, $T_A = +25^{\circ}C$, unless otherwise noted.)

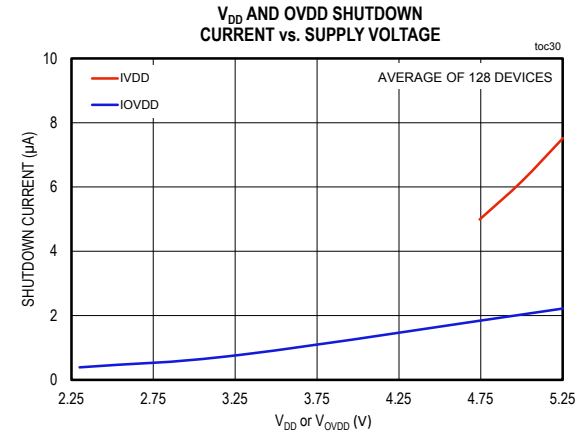
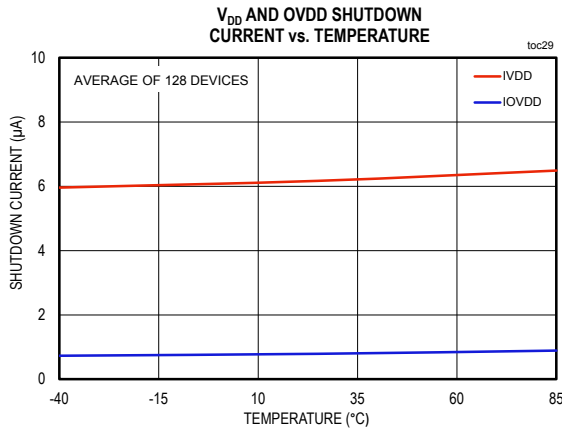
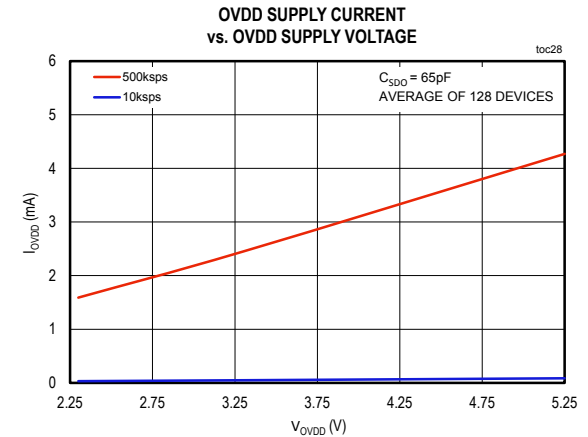
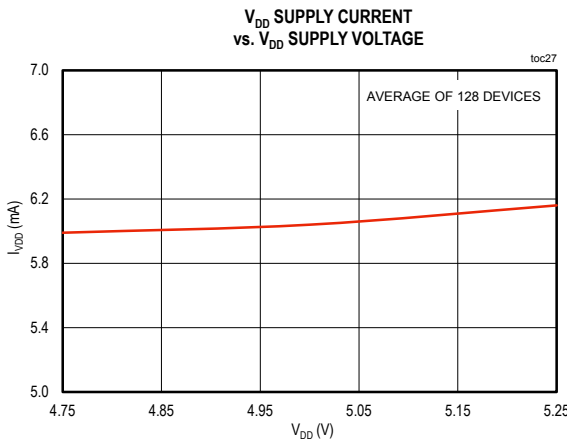
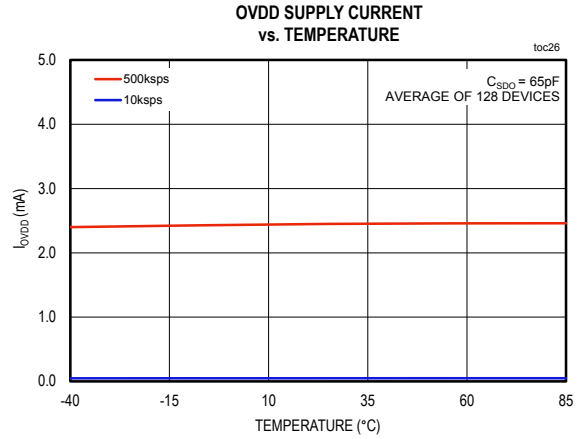
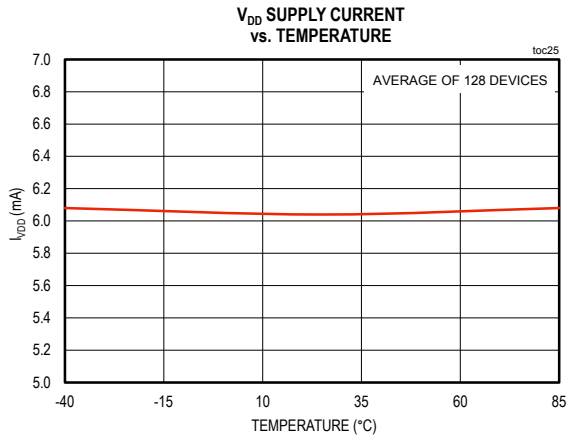

Pin Configuration

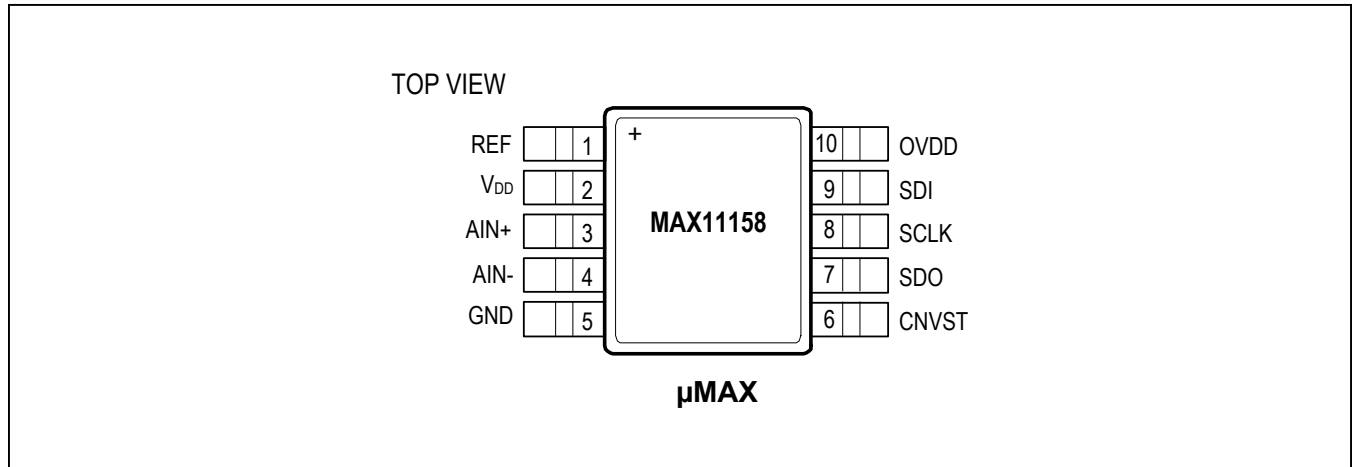

Pin Description

PIN	NAME	FUNCTION
1	REF	Internal Reference Bypass. Bypass to GND in close proximity with a X5R or X7R 10μF 16V capacitor. See the <i>Layout, Grounding, and Bypassing</i> section.
2	V _{DD}	Analog Power Supply. Bypass V _{DD} to GND with a 0.1μF capacitor as close as possible to each device and one 10μF capacitor per board.
3	AIN+	Positive Analog Input
4	AIN-	Negative Analog Input. Connect AIN- to the analog ground plane or to a remote sense ground.
5	GND	Power-Supply Ground
6	CNVST	Conversion Start Input. The rising edge of CNVST initiates the conversions and selects the interface mode: daisy-chain or \overline{CS} . In \overline{CS} mode, either SDI or CNVST can enable the serial output signals when low. If SDI or CNVST is low when the conversion is completed, the busy indicator feature is enabled..
7	SDO	Serial Data Output. SDO transitions on the falling edge of SCLK.
8	SCLK	Serial Clock Input. Clocks data out of the serial interface when the device is selected.
9	SDI	Serial Data Input and Mode Select Input. Daisy-chain mode is selected if SDI is low during the CNVST rising edge. In this mode, SDI is used as a data input to daisy-chain the conversion results of two or more ADCs onto a single SDO line. \overline{CS} mode is selected if SDI is high during the CNVST rising edge. In this mode, either SDI or CNVST can enable the serial output signals when low. If SDI or CNVST is low when the conversion is completed, the busy indicator feature is enabled.
10	OVDD	Digital Power Supply. OVDD can range from 2.3V to V _{DD} . Bypass OVDD to GND with a 0.1μF capacitor for each device and one 10μF per board.

Functional Diagram

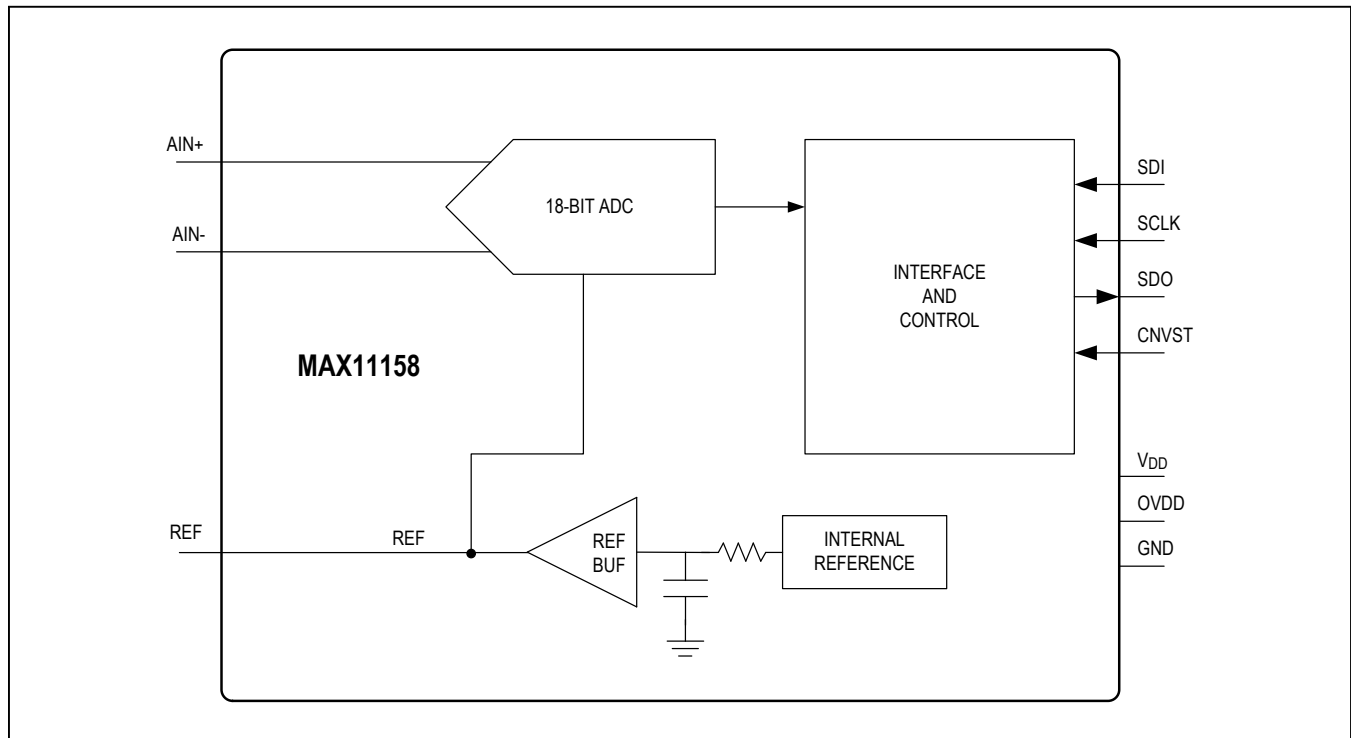

Detailed Description

The MAX11158 is an 18-bit single-channel, pseudo-differential ADC with maximum throughput rates of 500ksps. Both inputs (AIN+ and AIN-) are sampled with a pseudo-differential on-chip track-and-hold.

This ADC includes a precision internal reference.

The MAX11158 measures a true bipolar voltage of $\pm 5V$ ($10V_{P-P}$) and the inputs are protected for up to $\pm 20mA$ of overrange current. This ADC is powered from a 4.75V to 5.25V analog supply (V_{DD}) and a separate 2.3V to 5.25V digital supply ($OVDD$). The MAX11158 requires 500ns to acquire the input sample on an internal track-and-hold and then converts the sampled signal to 18 bits of resolution using an internally clocked converter.

Analog Inputs

The MAX11158 ADC consists of a true sampling pseudo-differential input stage with high-impedance, capacitive inputs. The internal T/H circuitry features a small-signal bandwidth of about 6MHz to provide 18-bit accurate sampling in 500ns. This allows for accurate sampling of a number of scanned channels through an external multiplexer.

The MAX11158 on the AIN+ input, accurately converts input signals in the interval from AIN- to $(\pm 5V + AIN-)$. AIN+ has a max input interval from -5.1V to +5.1V. AIN- has a max input interval from -0.1V to +0.1V. The MAX11158 performs a true differential sampling on inputs between AIN+ and AIN- with good common-mode rejection (see the [Typical Operating Circuit](#)). This allows for improved sampling of remote transducer inputs.

Many traditional ADCs with single supplies that measure bipolar input signals use resistive divider networks directly on the analog inputs. These networks increase the complexity of the input signal conditioning. However, the MAX11158 includes a patented input switch architecture that allows direct sampling of high-impedance sources. This architecture requires a minimum sample rate of 10Hz to maintain accurate conversions over the designed temperature and supply ranges.

Overvoltage Input Clamps

The MAX11158 includes an input clamping circuit that activates when the input voltage at AIN+ is above (V_{DD} + 300mV) or below -(V_{DD} + 300mV). The clamp circuit remains high impedance while the input signal is within the range of ±(V_{DD} + 100mV) and draws little to no current. However, when the input signal exceeds this range the clamps begin to turn on. Consequently, to obtain the highest accuracy, ensure that the input voltage does not exceed the range of ±(V_{DD} + 100mV).

To make use of the input clamps, connect a resistor (R_S) between the AIN+ input and the voltage source to limit the voltage at the analog input and to ensure the fault current into the devices does not exceed ±20mA. Note that the voltage at the AIN+ input pin limits to approximately 7V during a fault condition so the following equation can be used to calculate the value of R_S:

$$R_S = \frac{V_{FAULT\ MAX} - 7V}{20mA}$$

where V_{FAULT_{MAX}} is the maximum voltage that the source produces during a fault condition.

Figure 1 and Figure 2 illustrate the clamp circuit voltage current characteristics for a source impedance R_S = 1280Ω. While the input voltage is within the ±(V_{DD} + 300mV) range, no current flows in the input clamps. Once the input voltage goes beyond this voltage range, the clamps turn on and limit the voltage at the input pin.

Reference

The MAX11158 includes a precision internal reference source as well as an internal reference buffer circuit to drive the converter. The internal reference buffer requires a low inductance and ESR external decoupling capacitor of at least 10μF to be placed as close as possible to the reference pin.

Input Amplifier

The conversion results are accurate when the ADC acquires the input signal for an interval longer than the input signal's worst-case settling time. The ADC input sampling capacitor charges during the acquisition period. During this acquisition period, the settling of the sampled voltage is affected by the source resistance and the input sampling capacitance. Sampling error can be estimated by modeling the time constant of the total input capacitance and the driving source impedance.

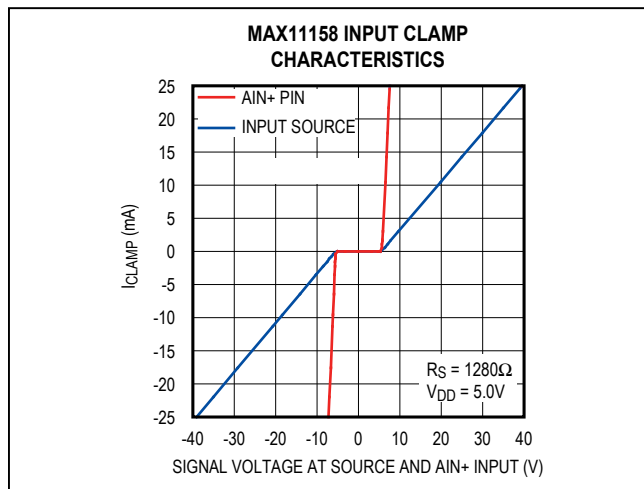

Figure 1. Input Clamp Characteristics

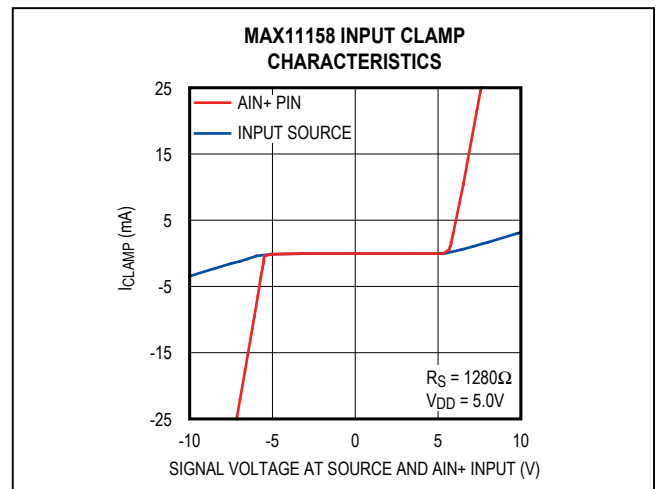

Figure 2. Input Clamp Characteristics (Zoom In)

Although the MAX11158 is easy to drive, an amplifier buffer is recommended if the source impedance is such that when driving a switch capacitor of ~40pF a settling error in the desired sampling period will occur. If this is the case, it is recommended that a configuration shown in the [Typical Operating Circuit](#) is used where at least a 2nF capacitor is attached to the AIN+ pin. This capacitance reduces the size of the transient at the start of the acquisition period, which will generate an input signal dependent offset error in some buffers..

Regardless of whether an external buffer amp is used or not, the time constant, $R_{SOURCE} \times C_{LOAD}$, of the input should not exceed $t_{ACQ}/12$, where R_{SOURCE} is the total signal source impedance, C_{LOAD} is the total capacitance at the ADC input (external and internal) and t_{ACQ} is the acquisition period. Thus to obtain accurate sampling in a 0.5μs acquisition time a source impedance of less than 1kΩ should be used if driving the ADC directly. When driving the ADC from a buffer, it is recommended a series resistance (5Ω to 50Ω typical) between the amplifier and the external input capacitance as shown in the [Typical Operating Circuit](#).

These amplifier features help to select the ADC driver:

- 1) Fast settling time: For multichannel multiplexed applications the driving operational amplifier must be able to settle to 18-bit resolution when a full-scale step is applied during the minimum acquisition time.

- 2) Low noise: It is important to ensure that the driver amplifier has a low average noise density appropriate for the desired bandwidth of the application. In the case of the MAX11158, settling in a 0.5μs duration requires a RC filter bandwidth of approximately 4MHz. With this bandwidth, it is preferable to use an amplifier that will produce an output noise spectral density of less than $4.5nV/\sqrt{Hz}$, to ensure that the overall SNR is not degraded significantly. It is recommended to insert an external RC filter at the MAX11158 AIN+ input to attenuate out-of-band input noise and preserve the ADCs SNR. The effective RMS noise at the MAX11158 AIN+ input is 76μV, thus additional noise from a buffer circuit should be significantly lower in order to achieve the maximum SNR performance.
- 3) THD performance: The input buffer amplifier used should have better THD performance than the MAX11158 to ensure the THD of the digitized signal is not degraded.

[Table 1](#) summarizes the operational amplifiers that are compatible with the MAX11158. The MAX9632 has sufficient bandwidth, low enough noise and distortion to support the full performance of the MAX11158. The MAX9633 is a dual amp and can support buffering for true pseudo-differential sampling.

Table 1. List of Recommended ADC Driver Op Amps for MAX11158

AMPLIFIER	INPUT-NOISE DENSITY (nV/√Hz)	SMALL-SIGNAL BANDWIDTH (MHz)	SLEW RATE (V/μs)	THD (dB)	I _{CC} (mA)	COMMENTS
MAX9632	1	55	30	-128	3.9	Low noise, THD at 10kHz
MAX9633	3	27	18	-128	3.5	Low noise, dual amp, THD at 10kHz

Transfer Function

The ideal transfer characteristic for the MAX11158 is shown in Figure 3. The precise location of various points on the transfer function are given in Table 2.

Digital Interface

The MAX11158 includes three digital inputs (CNVST, SCLK, and SDI) and a single digital output (SDO). The ADC can be configured for one of six interface modes, allowing the device to support a wide variety of application needs.

The 3-wire and 4-wire CS interface modes are compatible with SPI, QSPI, digital hosts, and DSPs. The 3-wire interface uses CNVST, SCLK, and SDO for minimal wiring complexity and is ideally suited for isolated applications. The 4-wire interface allows CNVST to be independent of output data readback (SDI) affording the highest level of individual device control. This configuration is useful for low jitter or multichannel, simultaneously sampled applications.

The 3-wire daisy-chain mode is the easiest way to configure a multichannel, simultaneous-sampling system. This system is built by cascading multiple ADCs into a shift register structure. The CNVST and SCLK inputs are common to all ADCs, while the SDO output of one device feeds the SDI input of the next device in the chain. The 3-wire interface is simply the CNVST, SCLK, and SDO of the last ADC in the chain.

The selection of CS or daisy-chain modes is controlled by the SDI logic level during the rising edge of CNVST. The CS mode is selected if SDI is high and the daisy-chain mode is selected if SDI is low. If SDI and CNVST are connected together, the daisy-chain mode is selected.

In each of the three modes described above (3-wire CS mode, 4-wire CS mode, and daisy-chain mode), the user must externally time out the maximum ADC conversion time before commencing readback. Alternatively, the MAX11158 offers a busy indicator feature on SDO in each mode to eliminate external timer circuits.

When busy indication is enabled, SDO provides a busy indicator bit to signal the end of conversion. One additional SCLK is required to flush the SDO busy indication bit prior to reading back the data. Busy indicator is enabled in CS

mode if CNVST or SDI is low when the ADC conversion completes. In daisy-chain mode, the busy indicator is selected based on the state of SCLK at the rising edge of CNVST. If SCLK is high, the busy indicator is enabled; otherwise, the busy indicator is not enabled.

The following sections provide specifics for each of the six serial interface modes. Due to the possibility of performance degradation, digital activity should only occur after conversion is completed or limited to the first half of the conversion phase. Having SCLK or SDI transitions near the sampling instant can also corrupt the input sample accuracy. Therefore, keep the digital inputs quiet for approximately 25ns before and 10ns after the rising edge of CNVST. These times are denoted as t_{SCKCNV} and t_{HCKCNV} in all subsequent timing diagrams.

In all interface modes, the data on SDO is valid on both SCLK edges. However, input setup time into the receiving host will be maximized when data is clocked into that host on the falling SCLK edge. Doing so will allow for higher data transfer rates between the MAX11158 and the receiving host and consequently higher converter throughput.

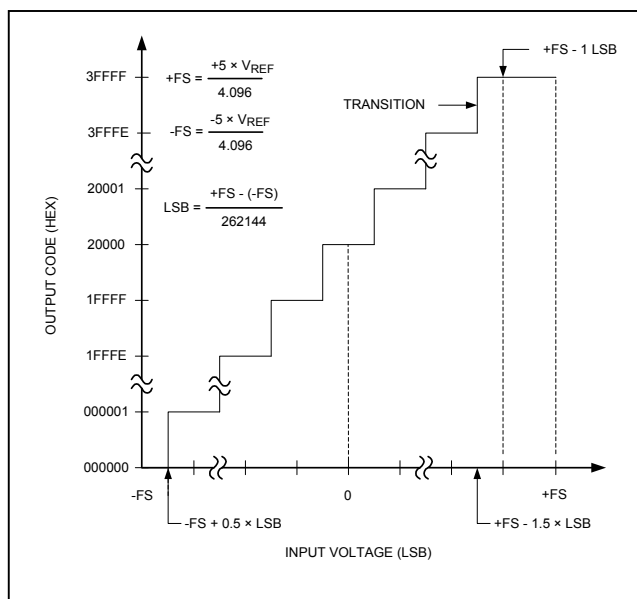

Figure 3. Bipolar Transfer Function

Table 2. Transfer Function Example

CODE TRANSITION	BIPOLAR INPUT (V)	DIGITAL OUTPUT CODE (HEX)
+FS - 1.5 LSB	+4.999943	3FFFE - 3FFFF
Midscale + 0.5 LSB	+0.000019	20000 - 20001
Midscale	0	20000
Midscale - 0.5 LSB	-0.000019	1FFFF - 20000
-FS + 0.5 LSB	-4.999981	00000 - 00001

Shutdown

In all interface modes, the MAX11158 can be placed into a shutdown state by holding SCLK high while pulling CNVST from high to low. Supply current is reduced to less than 10μA on both V_{DD} and OVDD supplies (see Figure 4). To wake up from shutdown mode, hold SCLK low and pull CNVST from high to low.

ADC Modes of Operation

The MAX11158 six modes of operation are summarized in Table 3. For each of the six modes of operation a typical application model and list of benefits are described.

CS Mode 3-Wire, No-Busy Indicator

The 3-wire \overline{CS} mode with no-busy indicator is ideally suited for isolated applications that require minimal wiring complexity. In Figure 5, a single ADC is connected to an SPI-compatible digital host with corresponding timing given in Figure 6.

With SDI connected to OVDD, a rising edge on CNVST completes the acquisition, initiates the conversion and forces SDO to high impedance. The conversion continues to completion irrespective of the state of CNVST, allowing CNVST to be used as a select line for other devices on the board. CNVST must be returned high before the minimum conversion time and held high until the maximum conversion time to avoid generating the busy signal indicator.

When the conversion is complete, the MAX11158 enters the acquisition phase. Drive CNVST low to output the MSB onto SDO. The remaining data bits are then clocked by subsequent SCLK falling edges. SDO returns to high impedance after the 18th SCLK falling edge or when CNVST goes high.

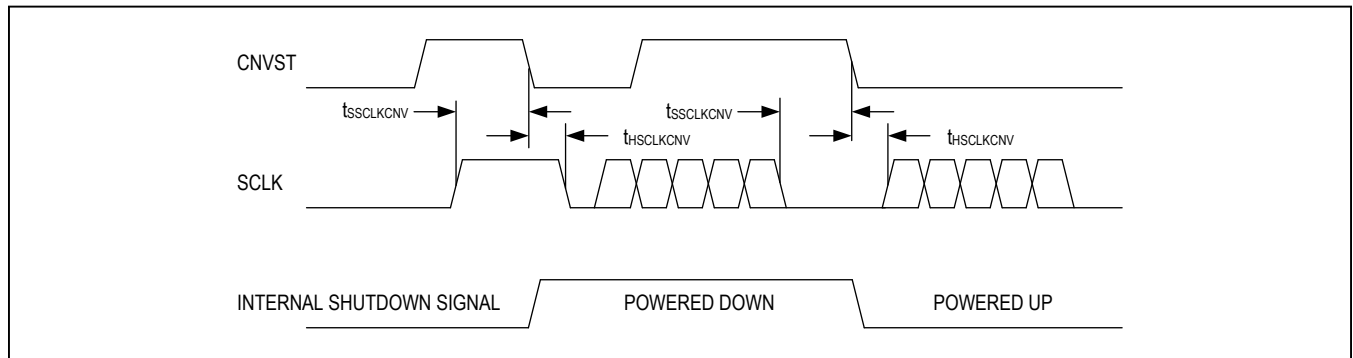

Figure 4. Entering and Exiting Shutdown Mode

Table 3. ADC Modes of Operation

MODE	TYPICAL APPLICATION AND BENEFITS
\overline{CS} Mode 3-Wire, No-Busy Indicator	Single ADC connected to SPI-compatible digital host. Minimal wiring complexity; ideally suited for isolated applications.
\overline{CS} Mode 3-Wire, With Busy Indicator	Single ADC connected to SPI-compatible digital host with interrupt input. Minimal wiring complexity; ideally suited for isolated applications.
\overline{CS} Mode 4-Wire, No-Busy Indicator	Multiple ADCs connected to SPI-compatible digital host. CNVST used for acquisition and conversion; ideally suited for low jitter applications and simultaneous sampling. SDI used to control data readback.
\overline{CS} Mode 4-Wire, With Busy Indicator	Single ADC connected to SPI-compatible digital host with interrupt input. CNVST used for acquisition and conversion; ideally suited for low jitter applications.
Daisy-Chain Mode, No-Busy Indicator	Multiple ADCs connected to 3-wire serial interface. Minimal wiring complexity; ideally suited for multichannel simultaneous sampled isolated applications.
Daisy-Chain Mode, With Busy Indicator	Multiple ADCs connected to 3-wire serial interface with busy indicator. Minimal wiring complexity; ideally suited for multichannel simultaneous sampled isolated applications.

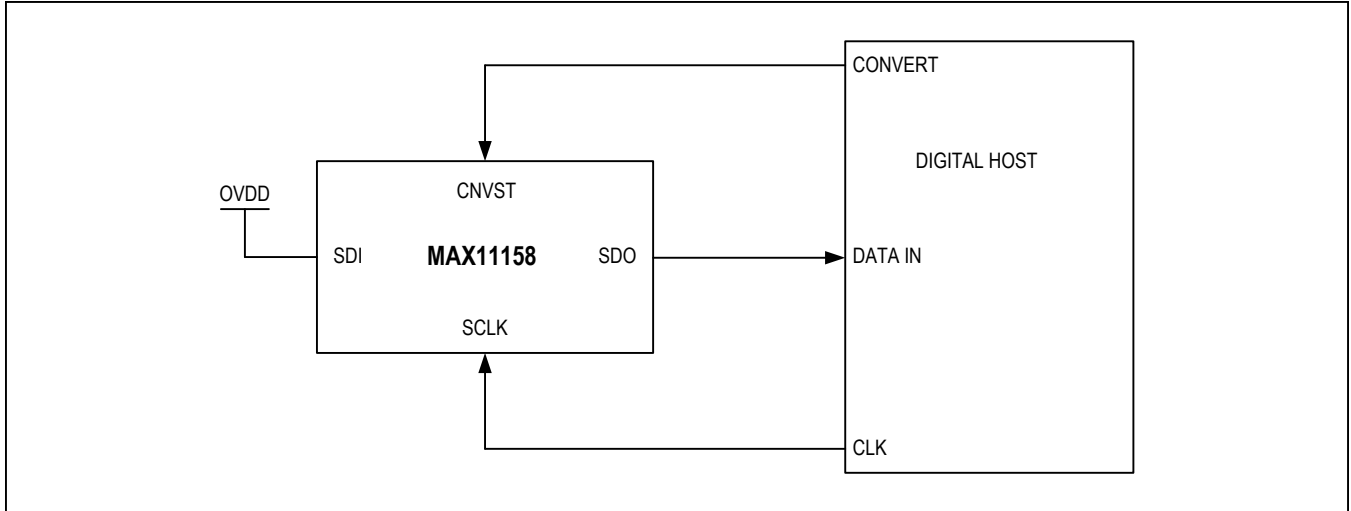

Figure 5. CS Mode 3-Wire, No-Busy Indicator Connection Diagram (SDI High)

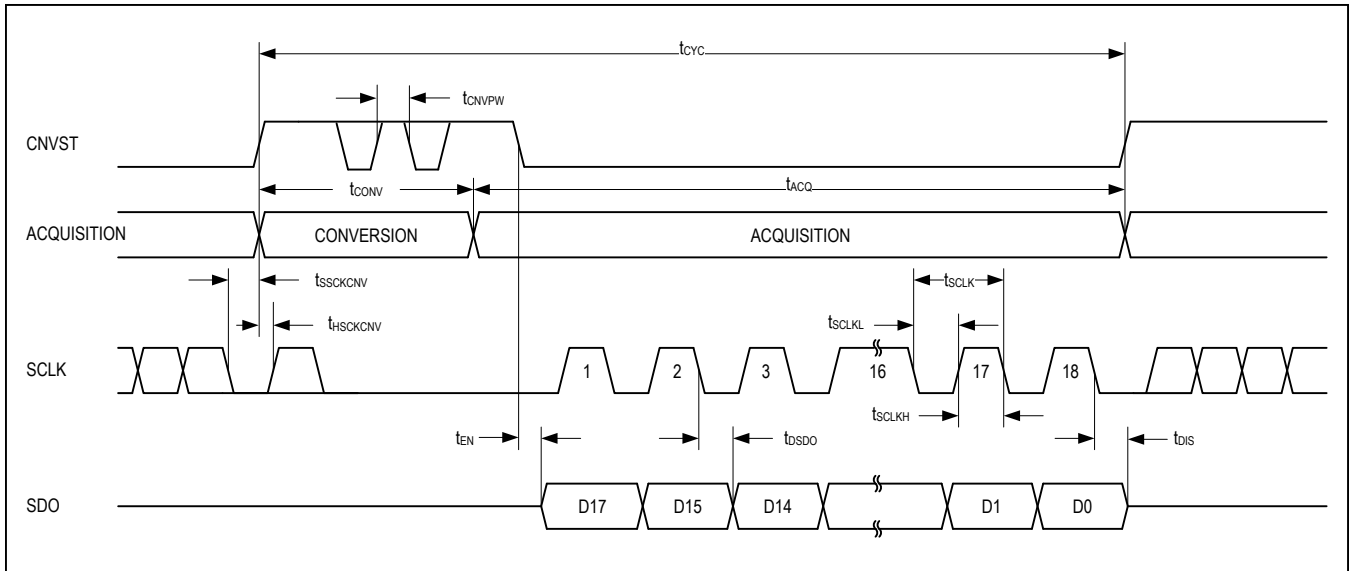

Figure 6. CS Mode 3-Wire, No-Busy Indicator Serial Interface Timing (SDI High)

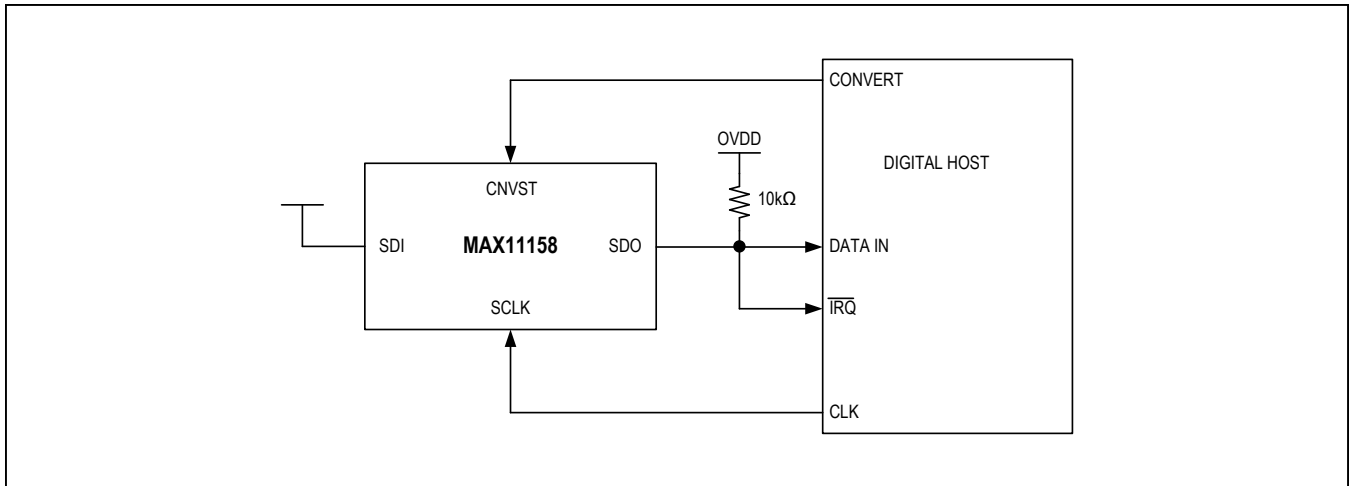

Figure 7. \overline{CS} Mode 3-Wire with Busy Indicator Connection Diagram (SDI High)

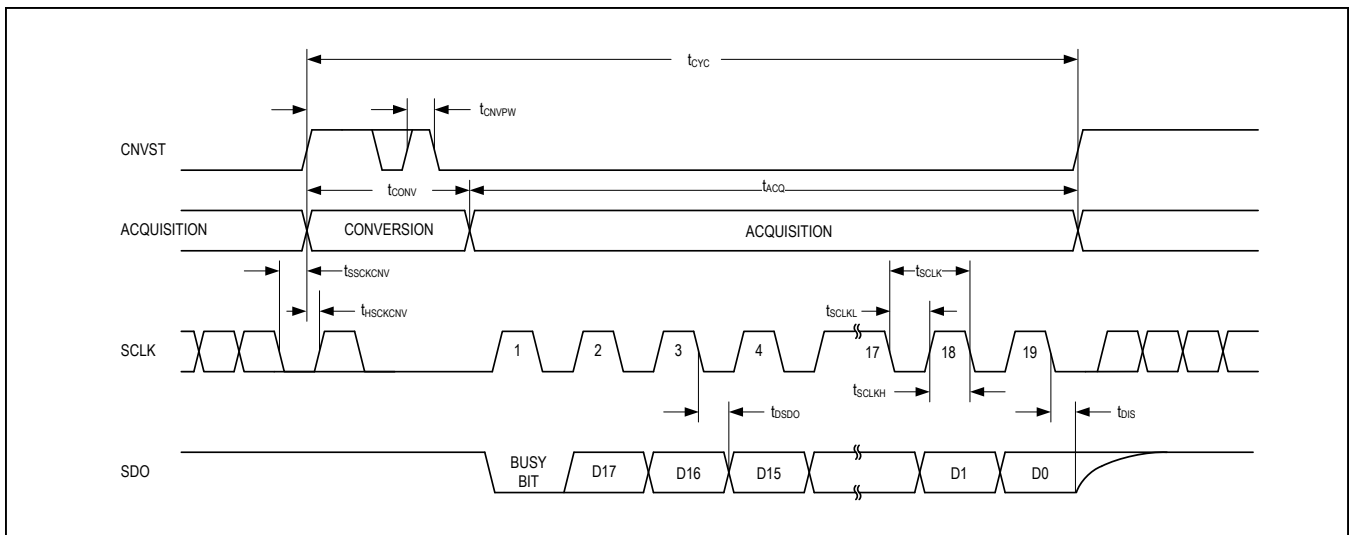

Figure 8. \overline{CS} Mode 3-Wire with Busy Indicator Serial Interface Timing (SDI High)

\overline{CS} Mode 3-Wire, With Busy Indicator

The 3-wire \overline{CS} mode with busy indicator is shown in [Figure 7](#) where a single ADC is connected to an SPI-compatible digital host with interrupt input. The corresponding timing is given in [Figure 8](#).

With SDI connected to OVDD, a rising edge on CNVST completes the acquisition, initiates the conversion and forces SDO to high impedance. The conversion continues to completion irrespective of the state of CNVST allowing CNVST to be used as a select line for other devices on the board. CNVST must be returned low before the minimum

conversion time and held low until the busy signal is generated. When the conversion is complete, SDO transitions from high impedance to a low logic level signaling to the digital host through the interrupt input that data readback can commence. The MAX11158 then enters the acquisition phase. The data bits are clocked out, MSB first, by subsequent SCLK falling edges. SDO returns to high impedance after the 19th SCLK falling edge or when CNVST goes high and is then pulled to OVDD through the external pullup resistor.

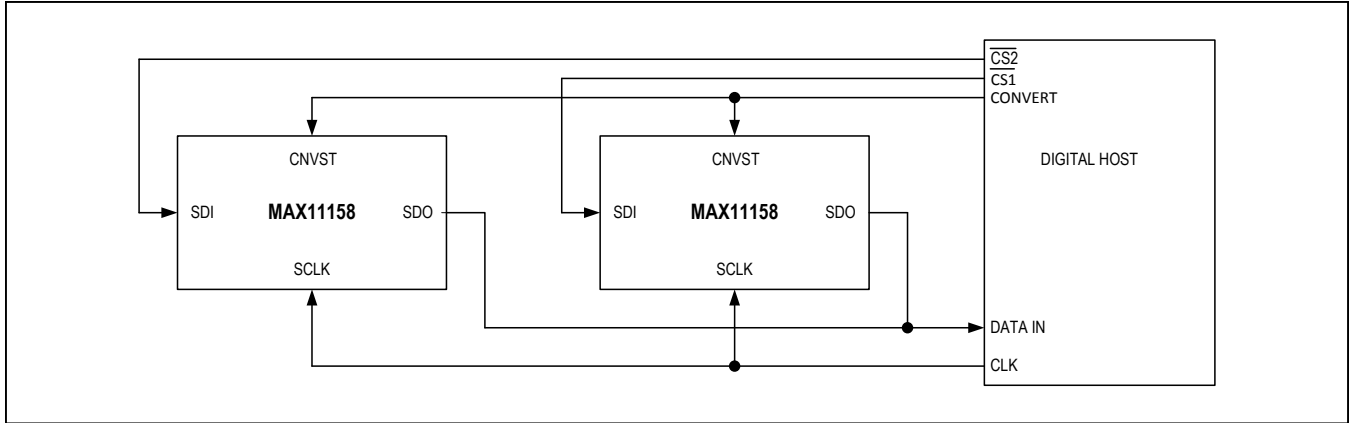

Figure 9. \overline{CS} Mode 4-Wire, No-Busy Indicator Connection Diagram

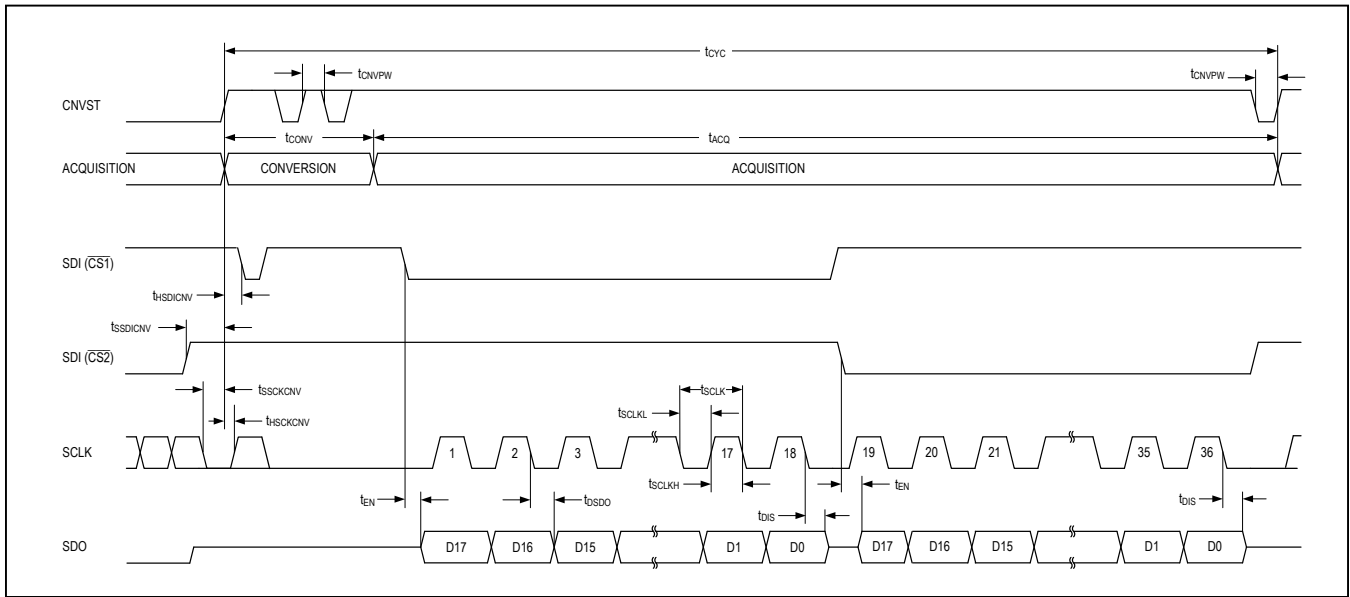

Figure 10. \overline{CS} Mode 4-Wire, No-Busy Indicator Serial Interface Timing

\overline{CS} Mode 4-Wire, No-Busy Indicator

The 4-wire \overline{CS} mode with no-busy indicator is ideally suited for multichannel applications. In this case, the CNVST pin may be used for low-jitter simultaneous sampling while the SDI pin(s) are used to control data readback. In [Figure 9](#), two ADCs are connected to an SPI-compatible digital host with corresponding timing given in [Figure 10](#).

With SDI high, a rising edge on CNVST completes the acquisition, initiates the conversion, and forces SDO to high impedance. This mode requires CNVST to be held high during the conversion and data readback phases. Note that if CNVST and SDI are low, SDO is driven low.

During the conversion, the SDI pin(s) can be used as a select line for other devices on the board, but must be returned high before the minimum conversion time and held high until the maximum conversion time to avoid generating the busy signal indicator.

When the conversion is complete, the MAX11158 enters the acquisition phase. ADC data is read by driving its respective SDI line low, outputting the MSB onto SDO. The remaining data bits are then clocked by subsequent SCLK falling edges. SDO returns to high impedance after the 18th SCLK falling edge or when CNVST goes high.

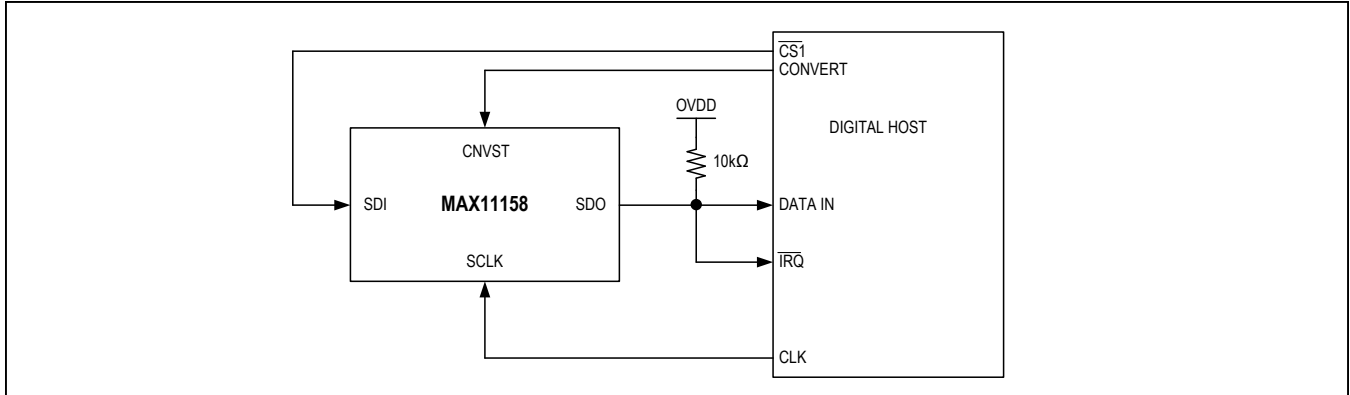

Figure 11. \overline{CS} Mode 4-Wire with Busy Indicator Connection Diagram

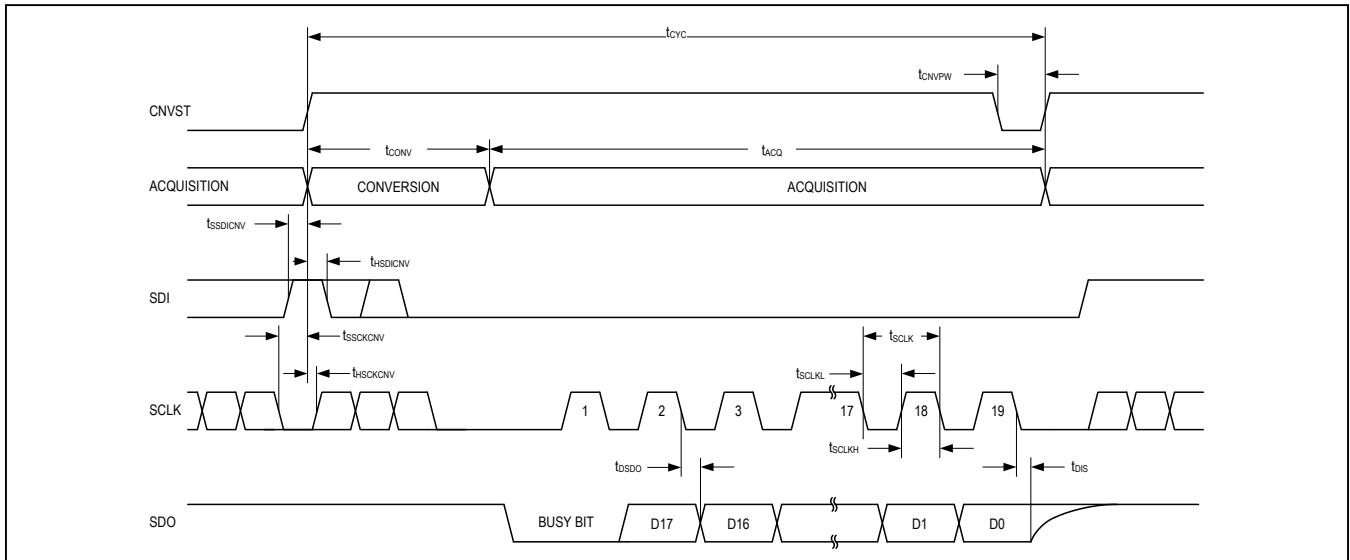

Figure 12. \overline{CS} Mode 4-Wire with Busy Indicator Serial Interface Timing

\overline{CS} Mode 4-Wire, With Busy Indicator

The 4-wire \overline{CS} mode with busy indicator is shown in [Figure 11](#) where a single ADC is connected to an SPI-compatible digital host with interrupt input. The corresponding timing is given in [Figure 12](#). This mode is ideally suited for single ADC applications where the CNVST pin may be used for low-jitter sampling while the SDI pin is used for data readback.

With SDI high, a rising edge on CNVST completes the acquisition, initiates the conversion and forces SDO to high impedance. This mode requires CNVST to be held high during the conversion and data readback phases. Note that if CNVST and SDI are low, SDO is driven low. During

the conversion, the SDI pin can be used as a select line for other devices on the board, but must be returned low before the minimum conversion time and held low until the busy signal is generated.

When the conversion is complete SDO transitions from high impedance to a low logic level signaling to the digital host through the interrupt input that data readback can commence. The MAX11158 then enters the acquisition phase. The data bits are clocked out, MSB first, by subsequent SCLK falling edges. SDO returns to high impedance after the 19th SCLK falling edge or when CNVST goes high and is then pulled to OVDD through the external pullup resistor.

The conversion data bits are stored within the internal shift register and clocked out on each subsequent SCLK falling edge. The SDI input of each ADC in the chain is used to transfer conversion data from the previous ADC into the internal shift register of the next ADC, thus allowing for data to be clocked through the multichip chain on each SCLK falling edge. With busy indicator mode selected, the busy bit from each part is not chained on the first falling SCLK edge in the readout pattern. Consequently, the number of falling SCLKs needed to read back all data from N ADCs is $18 \times N + 1$ falling edges.

In daisy-chain mode, the maximum conversion rate is reduced due to the increased readback time. For instance, with a 6ns digital host setup time and 3V interface, up to four MAX11158 devices running at a conversion rate of 308ksps can be daisy-chained on a 3-wire port.

Layout, Grounding, and Bypassing

For best performance, use PCBs with ground planes. Ensure that digital and analog signal lines are separated from each other. Do not run analog and digital lines parallel to one another (especially clock lines), and avoid running digital lines underneath the ADC package. A single solid GND plane configuration with digital signals routed from one direction and analog signals from the other provides the best performance. Connect the GND pin on the MAX11158 to this ground plane. Keep the ground return to the power supply low impedance and as short as possible for noise-free operation.

A 4.7nF C0G (or NPO) ceramic chip capacitor should be placed between AIN+ and the ground plane as close as possible to the MAX11158. This capacitor reduces the inductance seen by the sampling circuitry and reduces the voltage transient seen by the input source circuit. If AIN- is to be used for remote sense, put a matching 4.7nF C0G ceramic capacitor as close to this pin as well to minimize the effect to the inductance in the remote sense line.

For best performance, decouple the REF output to the ground plane with a 16V, 10 μ F or larger ceramic chip capacitor with a X5R or X7R dielectric in a 1210 or smaller case size. Ensure that all bypass capacitors are connected directly into the ground plane with an independent via.

Bypass V_{DD} and OVDD to the ground plane with 0.1 μ F ceramic chip capacitors on each pin as close as possible to the device to minimize parasitic inductance. Add at least one bulk 10 μ F decoupling capacitor to V_{DD} and OVDD per PCB. For best performance, bring a V_{DD} power plane in on the analog interface side of the MAX11158 and a OVDD power plane from the digital interface side of the device.

Definitions

Integral Nonlinearity

Integral nonlinearity (INL) is the deviation of the values on an actual transfer function from a straight line. For these devices, this straight line is a line drawn between the end points of the transfer function, once offset and gain errors have been nullified.

Differential Nonlinearity

Differential nonlinearity (DNL) is the difference between an actual step width and the ideal value of 1 LSB. For these devices, the DNL of each digital output code is measured and the worst-case value is reported in the [Electrical Characteristics](#) table. A DNL error specification of less than ± 1 LSB guarantees no missing codes and a monotonic transfer function.

Offset Error

For the MAX11158, the offset error is defined at code center 0x20000. This code center should occur at 0V input between AIN+ and AIN-. The offset error is the actual voltage required to produce code center 0x20000, expressed in LSB.

Gain Error

Gain error is defined as the difference between the actual change in analog input voltage range required to produce a top code transition minus a bottom code transition, subtracted from the ideal change in analog input voltage range.

Signal-to-Noise Ratio

For a waveform perfectly reconstructed from digital samples, signal-to-noise ratio (SNR) is the ratio of the full-scale analog input power to the RMS quantization error (residual error). The ideal, theoretical minimum analog-to-digital noise is caused by quantization noise error only and results directly from the ADC's resolution (N bits):

$$\text{SNR} = (6.02 \times N + 1.76)\text{dB}$$

In reality, there are other noise sources besides quantization noise: thermal noise, reference noise, clock jitter, etc. SNR is computed by taking the ratio of the power signal to the power noise, which includes all spectral components not including the fundamental, the first five harmonics, and the DC offset.

Signal-to-Noise Plus Distortion

Signal-to-noise plus distortion (SINAD) is the ratio of the fundamental input frequency's power to the power of all the other ADC output signals:

$$\text{SINAD(dB)} = 20 \times \log \left[\frac{\text{Signal}_{\text{RMS}}}{(\text{Noise} + \text{Distortion})_{\text{RMS}}} \right]$$

Effective Number of Bits

The effective number of bits (ENOB) indicates the global accuracy of an ADC at a specific input frequency and sampling rate. An ideal ADC's error consists of quantization noise only. With an input range equal to the full-scale range of the ADC, calculate the ENOB as follows:

$$\text{ENOB} = \frac{\text{SINAD} - 1.76}{6.02}$$

Total Harmonic Distortion

Total harmonic distortion (THD) is the ratio of the power contained in the first five harmonics of the converted data to the power of the fundamental. This is expressed as:

$$\text{THD} = 10 \times \log \left[\frac{P_2 + P_3 + P_4 + P_5}{P_1} \right]$$

where P_1 is the fundamental power and P_2 through P_5 is the power of the 2nd- through 5th-order harmonics.

Spurious-Free Dynamic Range

Spurious-free dynamic range (SFDR) is the ratio of the power of the fundamental (maximum signal component) to the power of the next-largest frequency component.

Aperture Delay

Aperture delay (t_{AD}) is the time delay from the sampling clock edge to the instant when an actual sample is taken.

Aperture Jitter

Aperture jitter (t_{AJ}) is the sample-to-sample variation in aperture delay.

Small-Signal Bandwidth

A small -20dBFS analog input signal is applied to an ADC in a manner that ensures that the signal's slew rate does not limit the ADC's performance. The input frequency is then swept up to the point where the amplitude of the digitized conversion result has decreased 3dB.

Full-Power Bandwidth

A large -0.5dBFS analog input signal is applied to an ADC, and the input frequency is swept up to the point where the amplitude of the digitized conversion result has decreased by 3dB. This point is defined as full-power input bandwidth frequency.

Selector Guide

PART	BITS	INPUT RANGE (V)	REFERENCE	PACKAGE	SPEED (ksps)
MAX11262	14	0 to 5	External	3mm x 5mm μ MAX-10	500
MAX11160	16	0 to 5	Internal	3mm x 5mm μ MAX-10	500
MAX11161	16	0 to 5	Internal	3mm x 5mm μ MAX-10	250
MAX11162	16	0 to 5	External	3mm x 5mm μ MAX-10	500
MAX11163	16	0 to 5	External	3mm x 5mm μ MAX-10	250
MAX11164	16	0 to 5	Internal/External	3mm x 3mm TDFN-12	500
MAX11165	16	0 to 5	Internal/External	3mm x 3mm TDFN-12	250
MAX11166	16	± 5	Internal/External	3mm x 3mm TDFN-12	500
MAX11167	16	± 5	Internal/External	3mm x 3mm TDFN-12	250
MAX11168	16	± 5	Internal	3mm x 5mm μ MAX-10	500
MAX11169	16	± 5	Internal	3mm x 5mm μ MAX-10	250
MAX11150	18	0 to 5	Internal	3mm x 5mm μ MAX-10	500
MAX11152	18	0 to 5	External	3mm x 5mm μ MAX-10	500
MAX11154	18	0 to 5	Internal/External	3mm x 3mm TDFN-12	500
MAX11156	18	± 5	Internal/External	3mm x 3mm TDFN-12	500
MAX11158	18	± 5	Internal	3mm x 5mm μ MAX-10	500

Ordering Information

PART	TEMP RANGE	PIN-PACKAGE
MAX11158EUB+	-40°C to +85°C	10 μ MAX

+Denotes a lead(Pb)-free/RoHS-compliant package.

Package Information

For the latest package outline information and land patterns (footprints), go to www.maximintegrated.com/packages. Note that a "+", "#", or "-" in the package code indicates RoHS status only. Package drawings may show a different suffix character, but the drawing pertains to the package regardless of RoHS status.

PACKAGE TYPE	PACKAGE CODE	OUTLINE NO.	LAND PATTERN NO.
10 μ MAX	U10+2	21-0061	90-0330